



NEMO | etc.

Certificate of Authorization #32455
353 Christian Street, Unit #13
Oxford, CT 06478
(203) 262-9245

ENGINEER

EVALUATE

TEST

CONSULT

P.E. EVALUATION REPORT (PEER)

GAF

1 Campus Drive
Parsippany, NJ 07054
(800) 766-3411

PEER-GAF-001.A.R18

FL6267-R18 (NON-HVHZ)

Date of Issuance: 02/28/2006

Revision 18: 10/12/2023

SCOPE:

This This P.E. Evaluation Report (henceforth 'PEER') is issued under **F.A.C. Rule 61G20-3** and the applicable rules and regulations governing the use of construction materials in the State of Florida. The documentation submitted has been reviewed by Robert Nieminen, P.E. for use of the product under the Florida Building Code. The products described herein have been evaluated for compliance with the **8th Edition (2023) Florida Building Code** [sections noted herein](#).

DESCRIPTION: GAF Attic Ventilation Products (NON-HVHZ)

LABELING: Labeling shall be in accordance with the requirements of the Accredited Quality Assurance Agency noted herein.

CONTINUED COMPLIANCE: This PEER is valid until such time as the named product(s) changes, the referenced Quality Assurance or production facility location(s) changes, or Code provisions that relate to the product(s) change. Acceptance of our PEERs by the named client constitutes agreement to notify NEMO ETC, LLC of any changes to the product(s), the Quality Assurance, or the production facility location(s). NEMO ETC, LLC requires a complete review of its PEER relative to updated Code requirements with each Code Cycle.

ADVERTISEMENT: The Florida Product Approval Number (FL#) preceded by the words "Nemo P.E. Evaluated" may be displayed in advertising literature. If any portion of the PEER is displayed, then it shall be done in its entirety.

INSPECTION: Upon request, a copy of this entire PEER shall be provided to the user by the manufacturer or its distributors and shall be available for inspection at the job site at the request of the Building Official.

This PEER consists of pages 1 through 11.

Prepared by:

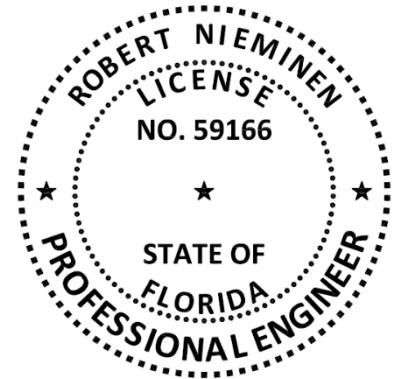

CERTIFICATION OF INDEPENDENCE:

1. NEMO ETC, LLC does not have, nor does it intend to acquire or will it acquire, a financial interest in any company manufacturing or distributing products it evaluates.
2. NEMO ETC, LLC is not owned, operated or controlled by any company manufacturing or distributing products it evaluates.
3. Robert Nieminen, P.E. does not have nor will acquire, a financial interest in any company manufacturing or distributing products for which the PEERs are being issued.
4. Robert Nieminen, P.E. does not have, nor will acquire, a financial interest in any other entity involved in the approval process of the product.
5. This is a building code evaluation. Neither NEMO ETC, LLC nor Robert Nieminen, P.E. are, in any way, the Designer of Record for any project on which this PEER, or previous versions thereof, is/was used for permitting or design guidance unless retained specifically for that purpose.

ROOFING COMPONENT EVALUATION:
1. SCOPE:

Product Category: Roofing
Sub-Category: Roofing Accessories that are an Integral Part of the Roofing System
Compliance Statement: **GAF Attic Ventilation Products**, as produced by **GAF**, have demonstrated compliance with the following sections of the **8th Edition (2023) Florida Building Code** through testing in accordance with the following Standards. Compliance is subject to the [Installation Requirements](#) and [Limitations of Use](#) set forth herein.

2. STANDARDS:

<u>SECTION</u>	<u>PROPERTY</u>	<u>STANDARD</u>
1504.3	Wind resistance	ASTM E330
1506.5, R904.5.1, 2304.10.5	Corrosion Resistance (of nails)	TAS 114, Appendix E
1523.6.5.2.13	Wind Driven Rain	TAS 100(A)
2606.4	Rate of burning	ASTM D635
2606.4	Self-ignition temperature	ASTM D1929
2615.2(2)	Weatherometer	ASTM G155

3. REFERENCES:

<u>ENTITY</u>	<u>EXAMINATION</u>	<u>REFERENCE</u>	<u>DATE</u>
ATI (TST 1558)	Physical Properties	01-49035.01	03/02/2004
ATI (TST 1558)	Wind Driven Rain	01-44964.01	01/15/2004
ATI (TST 1558)	Wind Driven Rain	60172.01-122-18	10/07/2005
ATI (TST 1558)	Physical Properties	59665.02-106-31	09/16/2005
ATI (TST 1558)	Wind Driven Rain	84608.01-106-18	11/12/2008
ATI (TST 1558)	Wind Driven Rain	A5250.01-109-18	02/18/2011
ATI (TST 1558)	Wind Uplift	87074.01-109-44	12/03/2008
ATI (TST 1558)	Wind Uplift	C2396.01-109-44	11/05/2012
ATI (TST 1558)	Wind Uplift	D1957.01-109-44	03/04/2014
ATI (TST 1558)	Wind Uplift	E0818.01-109-44	09/23/2014
ATI (TST 1558)	Physical Properties	D2702.01-106-18	06/30/2014
ATI (TST 1558)	Wind Uplift	E6744.01-109-44	04/30/2015
ATI (TST 1558)	Wind Driven Rain	G2331.01-109-44	01/10/2017
ATI (TST 1558)	Wind Driven Rain	G4123.01-109-18	01/10/2017
ATI (TST 1558)	Wind Uplift	G4123.02-109-44	01/10/2017
ITS (TST 1558)	Physical Properties	H5341.01-106-18 R1	01/22/2018
ITS (TST 1558)	Wind Driven Rain	G2331.03-109-18-R1	06/11/2019
PRI (TST 5878)	Weatherometer	HBP-007-02-01	06/24/2004
PRI (TST 5878)	Physical Properties	HBP-002-02-01	06/06/2001
PRI (TST 5878)	Wind Driven Rain	HBP-01-02-01	11/02/2000
PRI (TST 5878)	Wind Driven Rain	BRY-021-02-01	12/31/2003
PRI (TST 5878)	Physical Properties	BRY-025-02-01	09/17/2004
PRI (TST 5878)	Physical Properties	GAF-138-02-06	02/09/2007
PRI (TST 5878)	Wind Driven Rain	GAF-138-02-04	02/09/2007
PRI (TST 5878)	Wind Driven Rain	GAF-310-02-01	07/07/2011
PRI (TST 5878)	Wind Driven Rain	376T0008	07/25/2019
ETC Labs (TST 2411)	Physical Properties	ETC-01-718-10379.0	01/16/2000
ETC Labs (TST 2411)	Physical Properties	ETC-03-718-14602.0	01/20/2004
ETC Labs (TST 2411)	Physical Properties	ETC-07-718-19959.0	09/27/2007
Miami-Dade (CER 1592)	Corrosion Resistance (of nails)	Certification L 20-0423.01	05/07/2020
Miami-Dade (CER 1592)	Corrosion Resistance (of nails)	Certification L 22-0429.01	06/26/2022
Miami-Dade (CER 1592)	Corrosion Resistance (of nails)	Certification L 22-0914.03	06/06/2023
UL, LLC. (QUA 9625)	Quality Control	Service Confirmation	07/12/2022
UL, LLC. (QUA 9625)	Quality Control	Florida BCIS	Current

4. PRODUCT DESCRIPTION:

TABLE 1: EVALUATED VENTILATION PRODUCTS			
PRODUCT	PLANT(S)	DESCRIPTION	PUBLISHED NFVA¹
Cobra® Exhaust Vent	Acworth, GA	Low-profile attic ridge vent of mesh-construction for use in shingle roof systems with 12-inch width ridge cap shingles. The product measures 10½-inch wide supplied in 20 and 50 ft long rolls, and is supplied with corrosion resistant 1¾-inch coil nails (nail gun version) or 2½-inch Smart Nails™ (hand nail version).	14.1 (nail gun version) 16.9 (hand nail version)
Cobra® Rigid Vent 3™	Cumming, GA New Columbia, PA	Plastic, low-profile attic ridge vent for use in shingle roof systems with 12-inch width ridge caps. The product measures 13-13/16-inch wide supplied in 48-inch long sections, and is supplied with 3-inch corrosion resistant ring shank nails.	18
Cobra® Rigid Vent 3™ - 9"	Cumming, GA	Plastic, low-profile attic ridge vent for use in shingle roof systems with 10-inch width ridge caps. The product measures 11½-inch wide supplied in 48-inch long sections, and is supplied with 3-inch corrosion resistant ring shank nails.	18
Cobra® Snow Country®	Cumming, GA New Columbia, PA	Plastic, low-profile attic ridge vent with filter for use in shingle roof systems with 12-inch width ridge cap shingles. The product measures 13-13/16-inch wide supplied in 48-inch long sections.	18
Cobra® Snow Country® Advanced	Cumming, GA New Columbia, PA	Plastic, low-profile attic ridge vent with filter for use in shingle roof systems with 12-inch width ridge caps. The product measures 13-13/16-inch wide supplied in 48-inch long sections, and is supplied with 3-inch corrosion resistant ring shank nails.	18
Cobra® Snow Country® Advanced - 9"	Cumming, GA	Plastic, low-profile attic ridge vent with filter for use in shingle roof systems with 10-inch width ridge caps. The product measures 11½-inch wide supplied in 48-inch long sections, and is supplied with 3-inch corrosion resistant ring shank nails.	18
Cobra® RidgeRunner®	Cumming, GA	Polypropylene plastic, low-profile attic ridge vent for use in shingle roof systems with 12-inch width ridge cap shingles. The product measures 11½-inch wide supplied in 20 ft long rolls, and is supplied with corrosion resistant 1¾-inch coil nails.	12.5
TruSlate® Ridge Vent	Cumming, GA	Plastic, low-profile attic ridge vent for use in TruSlate® roof systems. The product measures 11.4-inch wide supplied in 48-inch long sections.	20
Cobra® Hip Vent	Cumming, GA	Plastic, low-profile attic hip vent with filter for use in shingle roof systems with 12-inch width hip shingles. The product, only for use on hips, measures nominal 11.4-inch wide supplied in 48-inch long sections, and is supplied with corrosion resistant 1¾-inch coil nails.	9
Cobra® IntakePro® Rooftop Intake Vent	Enka, NC	Woven plastic material pressed to form the molded shape. A woven fabric material is utilized on the top, bottom and front, below the vent channel of the mold. The vent is configured into a roll-out form, and is supplied with corrosion resistant 1¾-inch coil nails.	9

¹ Net Free Ventilation Area reported herein is as published by the manufacturer at the time of evaluation. The report user should verify current published data at the time of design and/or permitting to the satisfaction of the Authority Having Jurisdiction.

5. LIMITATIONS:

- 5.1 This is a building code evaluation. Neither NEMO ETC, LLC nor Robert Nieminen, P.E. are, in any way, the Designer of Record for any project on which this PEER, or previous versions thereof, is/was used for permitting or design guidance. PEERs are not to be construed as representing any attributes not specifically listed, nor are PEERs to be construed as an endorsement of the subject, or a recommendation for its use. There is no warranty by NEMO ETC, LLC or Robert Nieminen, P.E., express or implied, as to any finding or other matter in this PEER, or as to any product covered by the PEER.
- 5.2 This PEER is not for use in FBC High Velocity Hurricane Zone jurisdictions, as defined in FBC Chapter 2 (Broward and Miami-Dade Counties).
- 5.3 This PEER pertains to above-deck roof components. Roof decks and structural members shall be in accordance with FBC requirements to the satisfaction of the Authority Having Jurisdiction.
- 5.4 This PEER does not include evaluation of fire classification. Refer to **FBC 1505** or **R902** for requirements and limitations regarding roof assembly fire classification.

5.5 Minimum Roof Slopes:

TABLE 2: MINIMUM ROOF SLOPE	
PRODUCT	MINIMUM SLOPE
Cobra® Exhaust Vent	2:12
Cobra® Rigid Vent 3™	3:12
Cobra® Rigid Vent 3™ - 9"	3:12
Cobra® Snow Country®	3:12
Cobra® Snow Country® Advanced	3:12
Cobra® Snow Country® Advanced - 9"	3:12
Cobra® RidgeRunner®	3:12
TruSlate® Ridge Vent	5:12
Cobra® Hip Vent	Min. 3:12 to max. 12:12
Cobra® IntakePro® Rooftop Intake Vent	4:12

5.6 Wind Classification:

- 5.6.1 When installed in accordance with GAF standard attachment procedures, installation of **Cobra® Exhaust Vent, Cobra® Rigid Vent 3, Cobra® Rigid Vent 3 – 9”, Cobra® Snow Country®, Cobra® Snow Country® Advanced, Cobra® Snow Country® Advanced – 9”, Cobra® RidgeRunner®, TruSlate® Ridge Vent, Cobra® Hip Vent** and **Cobra® IntakePro®** is limited to maximum 33 ft mean roof height in Exposure B or C conditions. Refer to FBC 1609 or FBCR Chapter 3 for design wind speeds and exposure categories.
- 5.6.2 For installation on buildings outside these limitations, the performance limitations set forth in [Table 3](#) may be utilized. Allowable Design Pressure is the result of testing for wind load resistance based on allowable wind loads, and reflects the ultimate passing pressure divided by 2 (the 2 to 1 margin of safety per **FBC 1504.9** has already been applied). The Allowable Design Pressure shall meet or exceed critical design pressure determined by a qualified design professional in accordance with **FBC Chapter 16** or **FBCR Chapter 3**. No rational analysis is permitted.

TABLE 3: ALLOWABLE WIND UPLIFT		
SUBSTRATE:	PRODUCT	ALLOWABLE DESIGN PRESSURE (PSF)
Min. 7/16-inch plywood	Cobra® Exhaust Vent (nail gun version)	-150
Min. 7/16-inch plywood	Cobra® Exhaust Vent (hand nail version)	-180
Min. 7/16-inch plywood	Cobra® Rigid Vent 3™, Rigid Vent 3™ - 9”, Snow Country®, Snow Country® Advanced and Snow Country® Advanced - 9”	-215
Min. 7/16-inch OSB or plywood	Cobra® RidgeRunner®	-180

TABLE 3: ALLOWABLE WIND UPLIFT		
SUBSTRATE:	PRODUCT	ALLOWABLE DESIGN PRESSURE (PSF)
Min. 7/16-inch plywood	TruSlate® Ridge Vent	-190
Min. 7/16-inch plywood	Cobra® Hip Vent	-205
Min. 7/16-inch plywood	Cobra® IntakePro® Rooftop Intake Vent	-175

- 5.7 **GAF Attic Ventilation Products** are for use with asphalt-composition shingle roofs only.
- 5.8 Installation shall result in minimum net free ventilation area requirements set forth in **FBC 1203.2**.

6. INSTALLATION:

6.1 **GAF Attic Ventilation Products** shall be installed in accordance with **GAF** published installation instructions to the [Limitation of Use](#) herein and the specifics noted below.

6.2 COBRA® EXHAUST VENT:

- 6.2.1 Chalk a cut-line 1-inch off each side of the ridge and cut a slot along the apex of the roof measuring 2-inch (for truss construction) or 3½-inch (for ridge pole construction). The slot should terminate 6-inches from each end and 12-inches from hip intersections or chimneys. Cut only the sheathing; do not cut trusses. Figure A.
- 6.2.2 Unroll the vent along the entire length of the ridge, covering uncut 6-inch sheathing area on both ends. Shorter lengths can be joined by caulking and butting the ends. Figure B.
- 6.2.3 Apply a bead of polyurethane roof sealant to the underside of the entire perimeter of the vent and nail with min. 2½-inch galvanized roofing nails at each corner and 10-inch o.c.
- 6.2.4 Apply a bead of polyurethane roof sealant in the shape of a “C” to the underside of the entire perimeter of the cap shingles, and install cap shingles directly over the vent using Smart Nails™ or 1¾-inch corrosion resistant coil nails (supplied with the vent). Figure C.

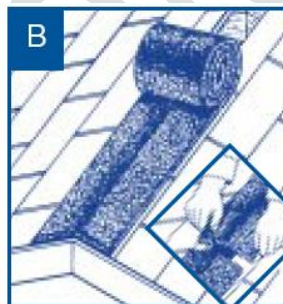

6.2.5 **Cobra® Exhaust Vent (hand nail version)** and **Cobra® Exhaust Vent (nail gun version)** have a ¾-inch or 5/8-inch nominal thickness, respectively, to facilitate ventilation. Care shall be taken not to crush or compact the product during installation. Figure D.

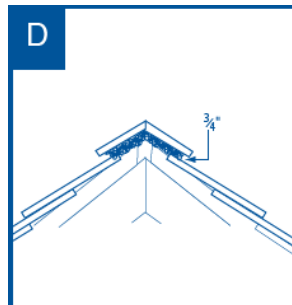

Hand-Nail Version

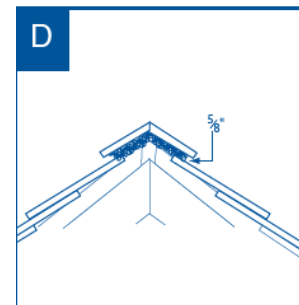

Nail Gun Version

6.3 COBRA® RIGID VENT 3™, RIGID VENT 3™-9", SNOW COUNTRY®, SNOW COUNTRY® ADVANCED AND ADVANCED-9":

6.3.1 Mark-off and cut the slot opening as follows, ensuring that the ends of the opening stop at least 6-inch from any end walls and at least 12-inch from hip and ridge intersections or chimneys.

No Ridge Board: Cut a 7/8-inch opening on each side of the ridge (Figure A).

With Ridge Board: Cut a 1-5/8-inch opening on each side of the ridge (Figure B).

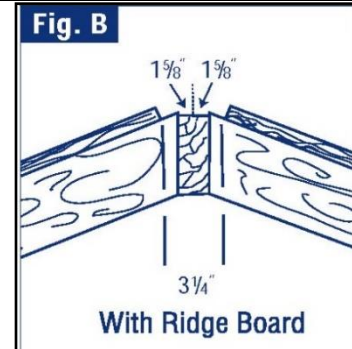
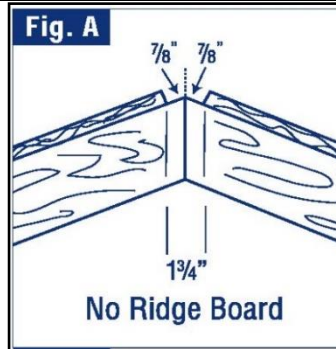

6.3.2 **Vent Placement:** Starting at one end of the slot, place, center and conform the Cobra® rigid vent over the slot with the vent firmly against the roof surface, ensuring the vent extends past the slot opening by at least 6-inch.

6.3.3 **Fasteners:** For Cobra® Rigid Vent 3™, Cobra® Rigid Vent 3™ - 9", Cobra® Snow Country® Advanced and Cobra® Snow Country® Advanced - 9" only, use the 3-inch corrosion resistant ring shank nails (included). For Cobra® Snow Country®, use corrosion resistant nails at least 3-inch or longer. Nails must always penetrate through plywood decks or at least 3/4-inch into wood planks. NOTE: GAF recommends 3-inch corrosion resistant ring shank nails for increased uplift resistance.

6.3.4 **Spacing:** Attach the vent section through the pre-molded nailing holes located at 3, 12, 24, 36 and 45-inch from the start of each 48-inch vent piece.

6.3.5 **Joints:** Apply the subsequent Cobra® rigid vent sections over the length of the ridge using the overlap/underlap tabs.

6.3.6 **Ridge Shingles:** Install ridge shingles in accordance with shingle manufacturer's published installation instructions, using corrosion resistant nails detailed in 6.3.3. A nail line is inscribed on top of the Cobra® rigid vent to serve as a guide.

6.4 COBRA® RIDGERUNNER®

6.4.1 Cut slot per 6.3.1.

6.4.2 Tear a 1-foot section to be used as a template for laying the vent out (Figure E-G) and center the template/ locator over the ridge cap shingles at the beginning of the vent slot. Note the location of the baffle (Figure H). Make sure to do this at both ends of the installation.

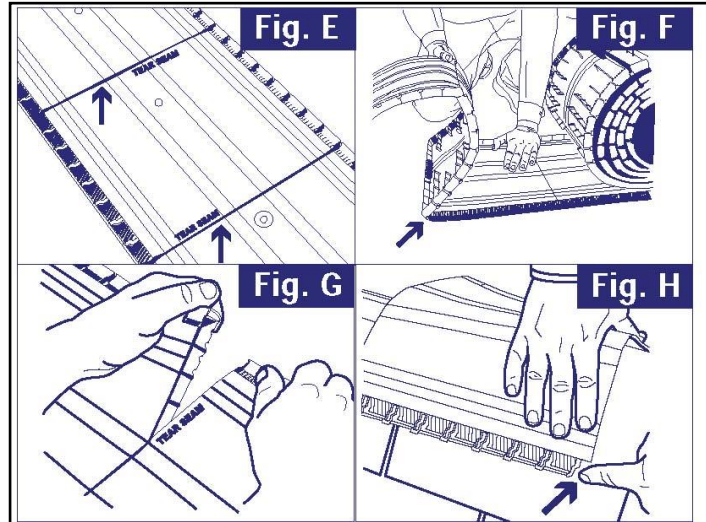

6.4.3 Measure the distance from the edge of the roof slot to the exterior baffle (D). Establish a chalk line along one side of the ridge (Figure I). Unroll the vent and use the included 1-3/4-inch pneumatic corrosion resistant roofing nails to attach the first side of the ridge vent with the exterior of the baffle aligned with the chalk line (Figure J). Proceed with using the 1' interval EasyTear™ system to custom size the vent to the appropriate length. If the EasyTear™ system can not be utilized, use a utility knife to size the vent. Nail gun targets are embossed on the part as a guide for property attaching vent to the roof. The vent should be fastened on 6-inch centers (Figure K).

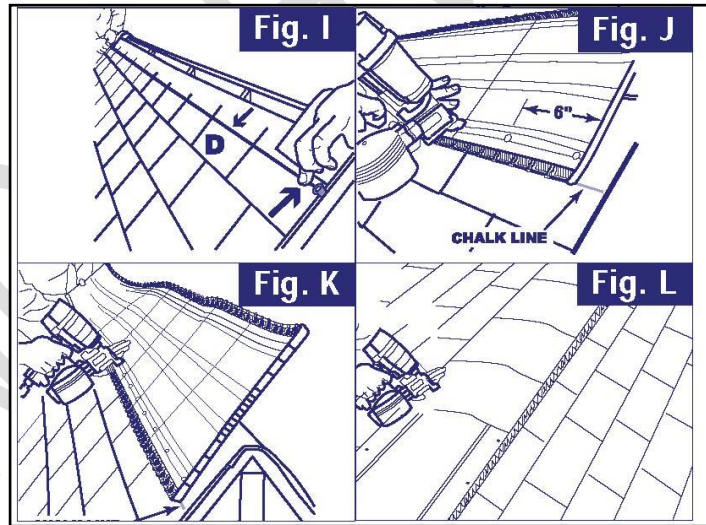

6.4.4 For installations over extra-thick shingles, a bead of polyurethane roof sealant may be applied to the underside of the outer baffle of the vent along both sides of the ridge and at exposed edges where the vent meets the shingles to fill any open space between the vent and shingles below.

6.4.5 **NOTE:** When fastening the vent and cap shingles, be sure that the included 1 3/4-inch corrosion resistant coil nails completely penetrate plywood or provide at least 3/4-inch penetration into wood planks. In the case they do not, you must use alternate corrosion resistant nails that provide the required penetration. Proceed with attaching the other side of the vent. When beginning to nail down the second side, do NOT begin at the end; begin between the first and second one-foot sections and then return to fasten the first one-foot section. This will allow for proper fit.

6.4.6 Install ridge shingles in accordance with shingle manufacturer’s published installation instructions, using the nail-lines on top of the ridge vent for proper lapping.

6.5 TRUSLATE® RIDGE VENT:

- 6.5.1 DO NOT use on hips.
- 6.5.2 Install **TruSlate® Ridge Vent** before installing the field slates.
- 6.5.3 After determining the total length of **TruSlate® Ridge Vent** required (for proper ventilation), determine the necessary slot opening. Mark-off and cut the slot opening, ensuring the ends of the opening stop at least 6-inch from any end walls and at least 12-inch from hip and ridge intersections or chimneys.

Roofs without a ridge board: Cut a 7/8-inch opening along the ridge on each side (Figure A).

Roofs with a ridge board: Cut a 1-5/8-inch opening along the ridge on each side (Figure B).

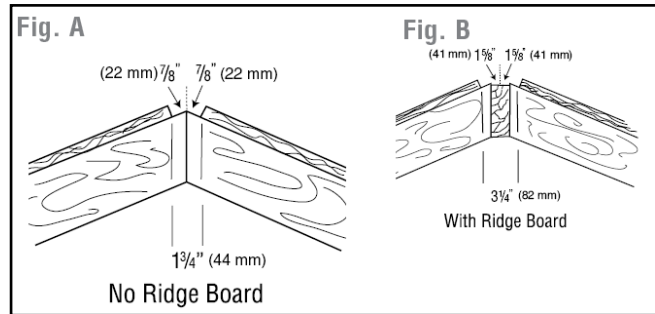

- 6.5.4 Install an 18-inch wide section of ASTM D1970 self-adhering leak barrier (holding Florida Statewide Product Approval or Approved on a Local Basis) from the edge of the ridge slot extending down towards the roof deck on both side of the slot.
- 6.5.5 Place the **TruSlate® Ridge Vent** over the ridge slot, “peaked” and centered over the ridge slot, and attach using minimum 3-inch long corrosion resistant ring-shank nails through the pre-molded nail holes on the vent, located 3-inch from the ends and 9-inch o.c. Fasteners shall penetrate through plywood decks or embed minimum 3/4-inch into wood plank decks.
- 6.5.6 Continue over the length of the ridge, utilizing the male/female connectors to connect units. Ensure the finished ends include the pre-molded end caps. Cover all exposed nail heads on the vent with silicone caulk. Install a bead of exterior grade silicone sealant at the downslope leading edges of the ridge vent, at the junction of the leading edge and the leak-barrier below.

- 6.5.7 Install the top course of TruSlate® field slates, UnderBlock™ UV & Moisture Barrier and TruSlate® trim slates in accordance with GAF published installation instructions. Install **TruSlate® trim slates** with 10-inch exposure using minimum **1-5/8-inch long deck screws** through pre-drilled holes, through the ridge vent to engage the wood deck.

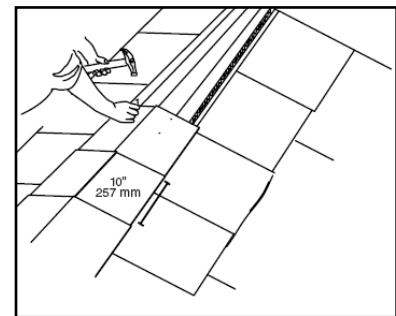
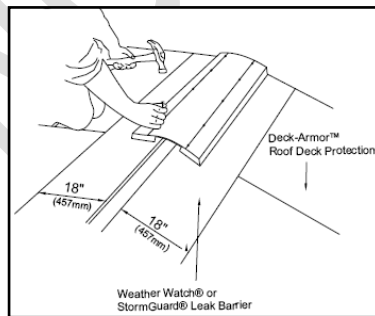

6.6 COBRA® HIP VENT

- 6.6.1 The roof deck shall consist of minimum of 7/16 inch thick plywood or OSB wood structural panels. Use only on roofs with slopes between 3:12 and 12:12. Install only on hips. Do not install Cobra® Hip Vent on ridges.
- 6.6.2 **Sequencing:** If ridge ventilation will be installed, always install the ridge vent to the end of the ridge before installing Cobra® Hip Vent.

6.6.3 **Hip Air Slot:** Determine the number of Cobra® Hip Vent sections needed for proper ventilation and the location for cuts in the roof hip. Cobra® Hip Vent is installed over a 2½ inch wide slot opening centered on the hip beginning at 12 inches below the top of the hip and extending 36 inches down the hip for every 4 foot section of Cobra® Hip Vent needed. Leave 12 inches of the hip uncut after each 36 inch opening, and the lowest opening must stop at the mid-point of the hip and more than 24 inches in from the exterior warm wall. Wider openings and slots below the midpoint of the hip will not improve ventilation and must be avoided. Cut away the shingles first with a roofing knife, and then cut the deck with a circular saw. The saw should be adjusted so that the rafters or trusses are not cut. Note: The roof decking must be re-nailed to the rafter at the edge closest to the hip to compensate for the nails removed when the hip slot was cut.

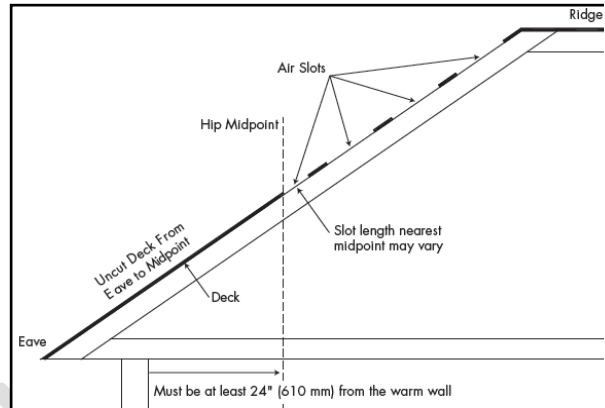

- 6.6.4 On plywood or OSB roof decks, where a sheathing seam intersects the hip air slot, stop cutting the air slot 2-inches (51 mm) before the seam and continue cutting the slot 2-inches (51 mm) after the seam, leaving a total of 4-inches (102 mm) of uncut deck at the seam. Then, proceed with cutting down to the previously marked 36-inch (914 mm) point. The air slot may be widened, in this case, to 5/8-inch (16 mm) on each side of the hip rafter to maintain proper NFVA.
- 6.6.5 **Sealant:** Seal all cut-edges of the asphalt shingles to the roof sheathing along all sides of the hip air slot openings, using a bead of ASTM C920 polyurethane sealant, to prevent water infiltration.
- 6.6.6 **Orientation:** Always install Cobra® Hip Vent with the "Towards Peak" arrows on the top surface of the vent pointing up towards the peak of the roof.

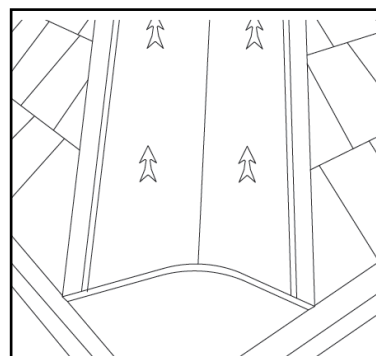

6.6.7 **Attachment:** Cobra® Hip Vent is fastened to the deck starting at the bottom of the hip and then up along the entire length of the hip (this includes un-cut portions of the hip). Fasten Cobra® Hip Vent to the deck with the included 1¾-inch long collated galvanized steel roofing nails, or longer corrosion resistant roofing fasteners, to achieve penetration through plywood or OSB decks or minimum 3/4-inch embedment into wood planks. Attach the Cobra® Hip Vent section through the pre-marked 6-inch increment nail targets.

- 6.6.8 **Joints & Terminations:** Apply the subsequent **Cobra® Hip Vent** sections over the length of the hip using the overlap/underlap tabs. For roofs with ridge vents, lengths of the hip vent must be butted tightly to sections of ridge vents and install a 3 inch by 12-inch strip of self-adhering leak barrier over all junctions. For roofs without ridge vents, sections of hip vent from adjacent hip runs must be mitered together tightly where they intersect and install a 3 inch by 12-inch strip of self-adhering leak barrier over all junctions. Refer to GAF published installation instruction for details.
- 6.6.9 **Ridge Shingles: Cobra® Hip Vent** is then covered with ridge cap shingles and this entire assembly is nailed to the sheathing with the included 1¾-inch long collated galvanized steel roofing nails. Depending on the field and ridge cap shingles used, longer length corrosion resistant fasteners may be necessary. The ridge cap shingles are installed per the shingle manufacturer's instructions and Florida Product Approval, with a minimum of two nails per shingle and a shingle to shingle nail spacing of 8 inches on center or less. Refer to the shingle manufacturer's Florida Product Approval for ridge cap shingle fastening and sealing requirements. Do not overdrive the nails or crush/compact the product during installation.

6.7 COBRA® INTAKEPRO® ROOFTOP INTAKE VENT

- 6.7.1 The roof deck shall consist of minimum of 7/16 inch thick plywood or OSB wood structural panels. Use only on roofs with minimum slope of 4:12. Install only on eave edges of the roof.
- 6.7.2 Determine the length of Cobra® IntakePro® Rooftop Intake Vent sections needed for proper ventilation and the location for cuts near the roof eave edge. Install a metal drip edge at the eave of the roof. Measure up 6 and 7 inches up from the edge of the metal drip edge and strike chalk lines parallel to the eave of the roof. Cut a 1 inch wide air slot opening along the chalk lines, stopping a minimum of 12" (305 mm) from rake/gable edges, side/end walls, and hip intersections, and stopping a minimum of 24" (610 mm) from the center of valley intersections. The saw should be adjusted so that the rafters or trusses are not cut.
- Note: After cutting the air slot, clear all debris blocking access into the attic space. Be sure to flatten attic insulation near the air slot to allow for proper intake airflow near the air slot. Attic baffles may be used to help prevent insulation from blocking intake airflow into the attic space.
- 6.7.3 Install a minimum 18 inch (457mm) wide FBC Approved peel-and-stick leak barrier down to the roof deck. Align peel-and-stick leak barrier flush to the edge of the roof on top of the drip edge metal. Use a sharp utility knife to cut the leak barrier, re-opening the 1 inch (25 mm) air slot that was previously cut in the deck.
- 6.7.4 Each roll of Cobra® IntakePro® Rooftop Intake Vent comes with two pieces of end cap fabric. To begin the vent run, place one piece of end cap fabric overhanging halfway over the rake/gable edge and parallel to the eave drip edge. Fasten the fabric to the roof deck using two roofing nails, one high and one low. If necessary, a piece of FBC Approved peel-and-stick leak barrier can be used in lieu of end cap fabric.
- 6.7.5 With the pre-marked dotted nail line and GAF logo facing up toward the sky, position the vent on top of the fabric end cap and flush to the rake/gable edge and eave drip edge. The front venting face of the vent should be flush with the drip edge metal below. Using the included 1-3/4 inch (44 mm) pneumatic coil nails, fasten the vent every 6 inches (152 mm) along the pre-marked nail line and fasten every 12 inches (305 mm), approximately 1-1/2 inches (38 mm) down from the up-slope edge of the vent. Do NOT nail within 1 inch (25 mm) from the side, top, or bottom edges of the vent.
- 6.7.6 Continue installing vent toward the opposite gable/rake edge or termination point. When installing multiple rolls, adjoin the rolls by butting them tightly together. There should be no gap between adjoining sections. The vent must always extend a minimum of 12 inches (305 mm) past any air slots. Miter cut the vent at any valley and hip intersections, ensuring the vent sections are butted tightly together. For terminations at gable and rake edges, cover the end of the vent run using the included fabric end cap in the same manner as the start of the vent run.
- 6.7.7 Install FBC Approved peel-and-stick leak barrier completely covering the top of the vent and extending from the eave edge to a minimum of 24 inches (610 mm) in from the building's warm wall. The leak barrier should not overhang the vent. Install rake drip edge if necessary.

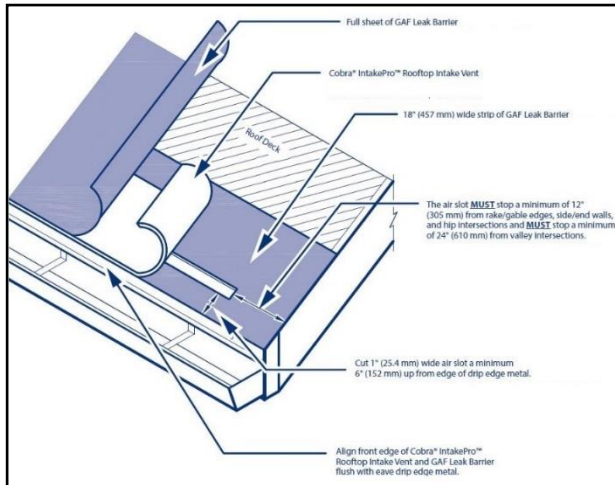

- 6.7.8 Begin installing the shingle starter course. The starter course and first course of field shingles should overhang the front edge of the Cobra® IntakePro® Rooftop Intake Vent by 1/4 – 3/4 inches (6 – 19 mm) to provide a drip edge. Using the included 1-3/4 inch (44 mm) pneumatic coil nails, fasten the starter strip and field shingles as per manufacturer’s installation instructions. Ensure the field shingles are not fastened into the open air intake slot below.

7. BUILDING PERMIT REQUIREMENTS:

As required by the Building Official or Authority Having Jurisdiction to properly evaluate the installation of this product.

8. MANUFACTURING PLANTS:

Contact the named QA entity for manufacturing facilities covered by F.A.C. [Rule 61G20-3](#)QA requirements. Refer to [Section 4](#) herein for products and production locations having met codified material standards.

9. QUALITY ASSURANCE ENTITY:

[UL, LLC. \(QUA9625\)](#): (360) 817-5512; bsai.inspections@ul.com

- END OF PEER -