

L'TR	REVISION	DATE	BY	E.C.O.
*	ORIGINAL ISSUE	10/02/2018	TJE	1853

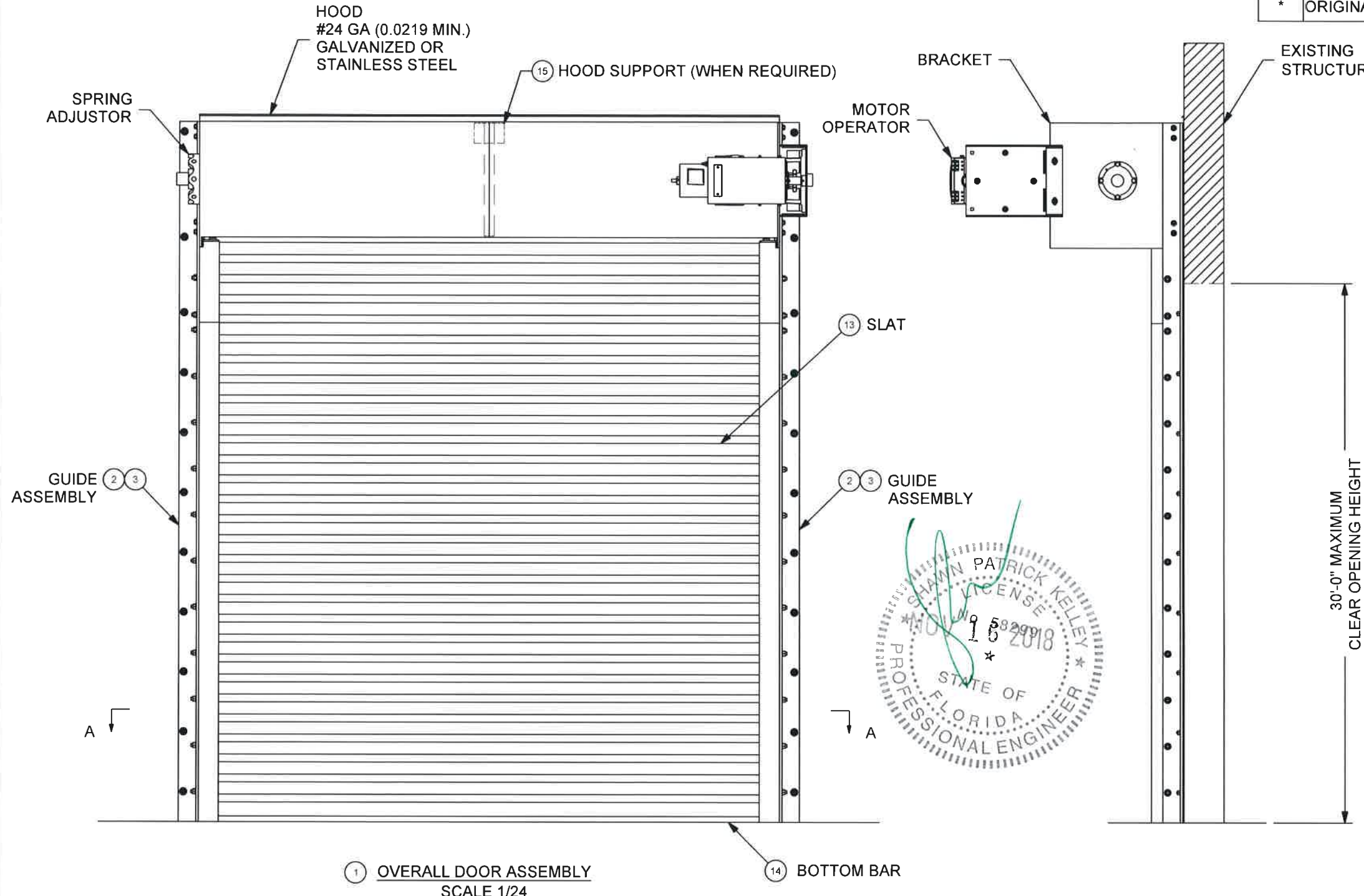

- NOTES:
1. THESE PRODUCT EVALUATION DOCUMENTS REPRESENT A ROLL-UP DOOR ASSEMBLY DESIGNED AND TESTED IN ACCORDANCE WITH THE STANDARD BUILDING CODE, THE INTERNATIONAL BUILDING CODE, AND THE FLORIDA BUILDING CODE.
  2. POSITIVE AND NEGATIVE DESIGN PRESSURE CALCULATIONS SHALL BE PERFORMED FOR SPECIFIC JOBS IN ACCORDANCE WITH ASCE 7 MINIMUM DESIGN LOADS FOR BUILDINGS AND OTHER STRUCTURES. WIND LOADS DETERMINED FOR OPENINGS SHALL BE LESS THAN OR EQUAL TO DOOR DESIGN PRESSURES NOTED BELOW.  
 POSITIVE DESIGN LOAD = 200 PSF  
 NEGATIVE DESIGN LOAD = 200 PSF
  3. THE DETAILS AND SPECIFICATIONS SHOWN HEREIN REPRESENT THE PRODUCTS TESTED FOR UNIFORM STATIC AIR PRESSURE IN CONFORMANCE WITH FLORIDA BUILDING CODE TEST PROTOCOLS TAS 201, 202, AND 203.  
 POSITIVE DESIGN LOAD = 200 PSF  
 NEGATIVE DESIGN LOAD = 200 PSF
  4. TESTING PERFORMED BY INTERTEK. (YORK, PENNSYLVANIA) TEST REPORT No. H7081.02-109-18.
  5. THESE PRODUCT EVALUATION DOCUMENTS ARE SUITABLE TO BE APPLIED BY THE CONTRACTOR PROVIDED THE CONTRACTOR DOES NOT DEVIATE FROM THE CONDITIONS DETAILED HEREIN AND THE CONTRACTOR VERIFIES THE EXISTING STRUCTURE IS CAPABLE OF SUPPORTING THE SUPERIMPOSED LOADS Vx & Vy ON THE JAMBS OF THE DOOR.
  6. ALL WELDING SHALL BE PERFORMED BY QUALIFIED WELDERS IN ACCORDANCE WITH AWS SPECIFICATIONS, LATEST EDITION. ALL WELDING ELECTRODES SHALL CONFORM TO AWS A5.1, GRADE E-70. MINIMUM WELDING PROCESS SHALL BE ARC WELDING AWS E7014 OR MIG WELDING AWS ER70S-6.
  7. ANCHOR NOTES:  
 A. EMBEDMENT DEPTH DOES NOT INCLUDE STUCCO FINISH.  
 B. ANCHORS SHALL BE INSTALLED IN ACCORDANCE WITH MANUFACTURERS SPECIFICATIONS.
  8. DOOR MAY BE INSTALLED ON THE INSIDE OR OUTSIDE OF AN EXTERIOR WALL.
  9. A 33% INCREASE IN ALLOWABLE STRESS HAS NOT BEEN USED IN THE DESIGN OF THIS PRODUCT.
  10. NO LOCKING REQUIRED FOR WINDLOAD RESISTANCE.
  11. WINDLOCKS ARE INTEGRAL TO THE SLAT.
  12. GUIDE ASSEMBLY, BOTTOM BAR & CURTAIN ARE TO BE PROTECTED FROM CORROSION WITH POLYESTER POWDER COATING WHEN NOT MINIMUM G90 GALVANIZED STEEL OR STAINLESS STEEL.

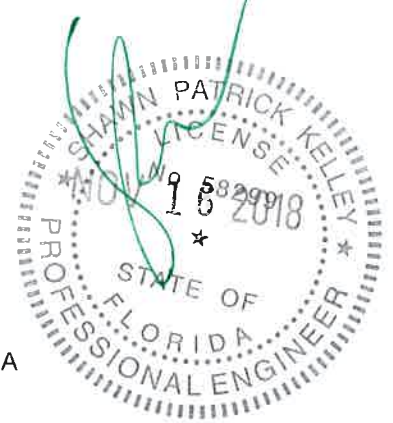

1 OVERALL DOOR ASSEMBLY SCALE 1/24  
 14 BOTTOM BAR

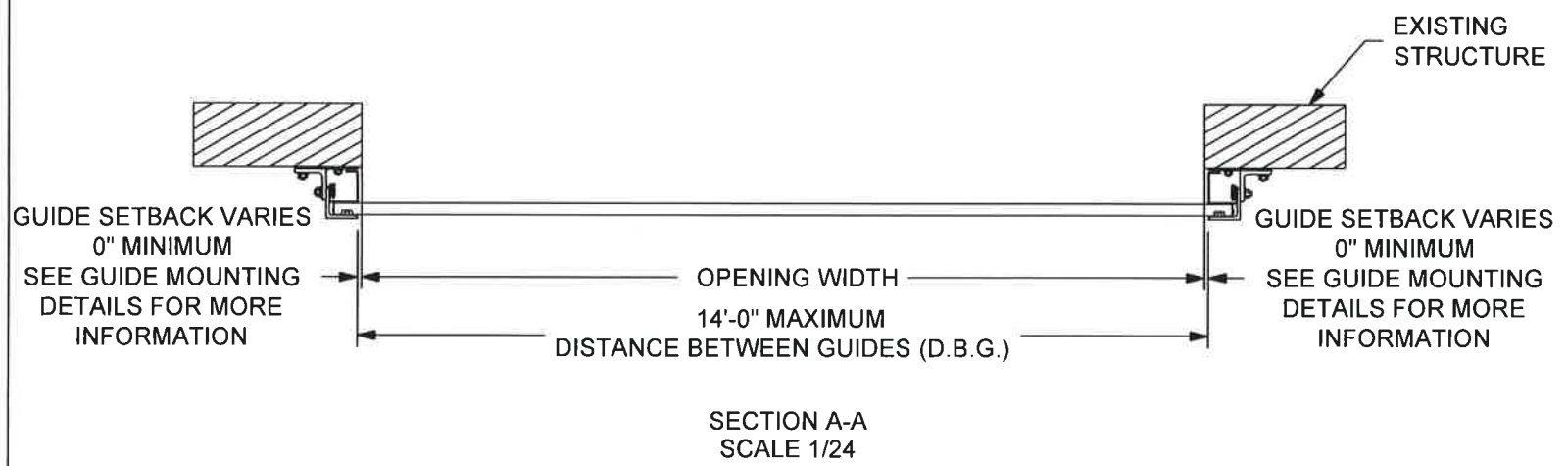

SECTION A-A SCALE 1/24

	24 ELMWOOD AVE 1901 S. LITCHFIELD RD MOUNTAINTOP, PA GOODYEAR, AZ	Unless otherwise specified, dimensions are in inches & tolerances are:  0.000 = +/- 0.031 FRACTIONAL = +/- 1/32 ANGLES = +/- 1/2 DEG		
	P: 800.390.8590 F: 866.448.6798 E: ADS@COOKSONDOOR.COM			
TITLE: <b>STORMDEFENDER NON-INSULATED          ROLLING STEEL DOOR 200 PSF 80 FPS</b>	DRAWN BY: <b>TJE</b>	SIZE: <b>B</b>	SCALE: <b>AS NOTED</b>	SHEET: <b>1/7</b>
DWG NO: <b>ES-16-80-TCCI</b>				

L'TR	REVISION	DATE	BY	E.C.O.
*	ORIGINAL ISSUE	10/02/2018	TJE	1853

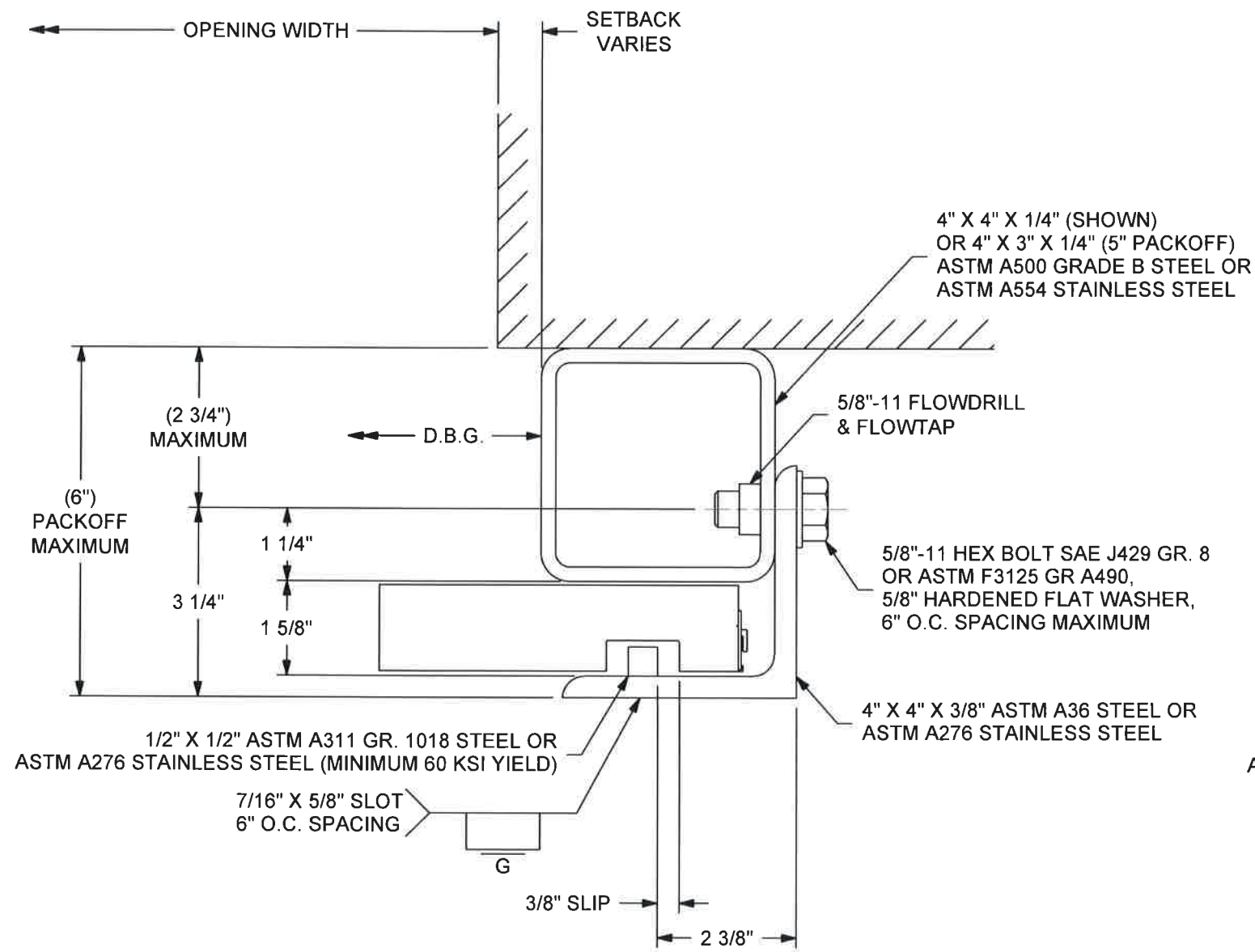

② GUIDE ASSEMBLY - BOX GUIDE  
SCALE 3/8

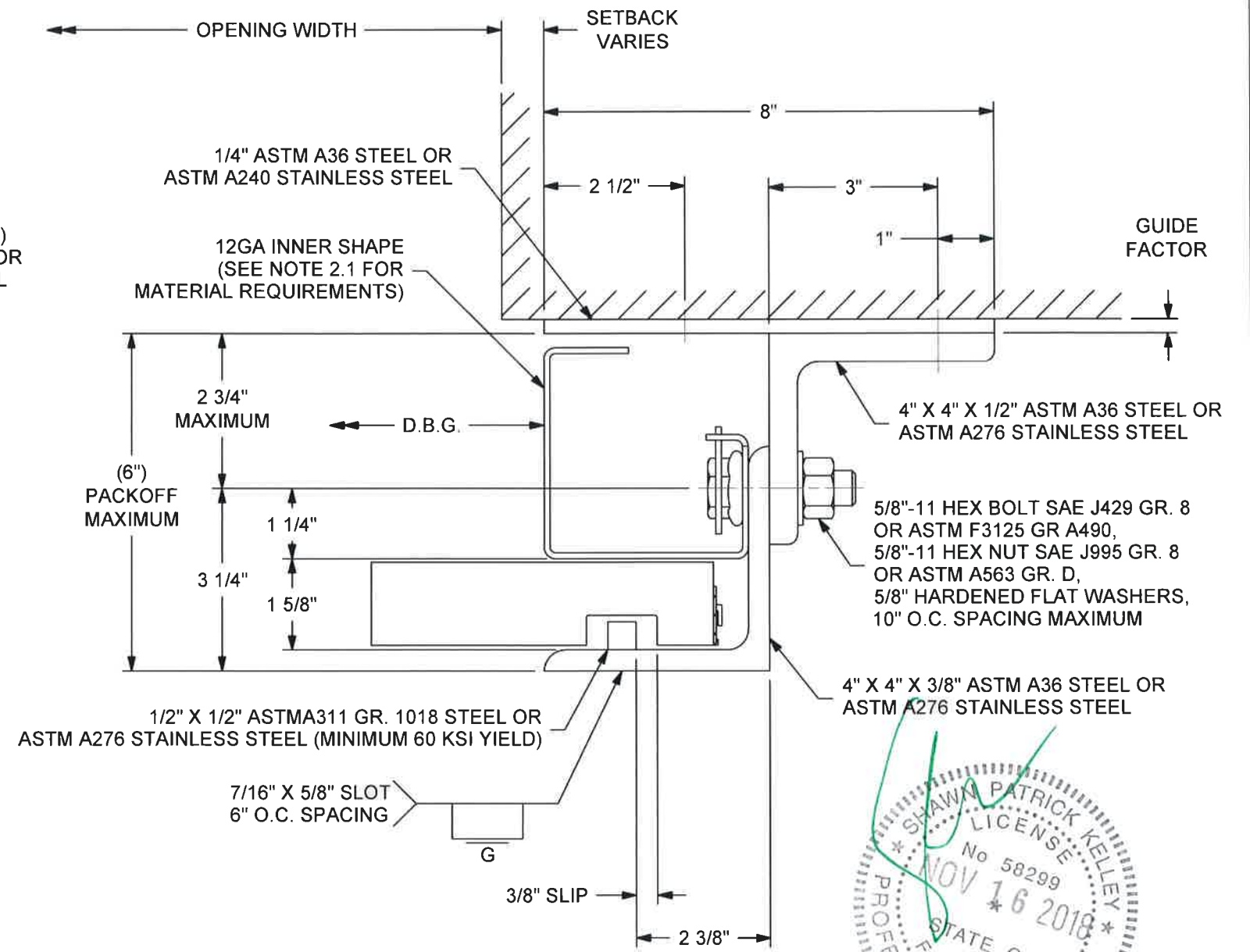

③ GUIDE ASSEMBLY - Z GUIDE  
SCALE 3/8

NOTES:  
2.1 SHEET MATERIAL: ASTM A1011 CS TYPE B (MINIMUM 40 KSI YIELD), SS GRADE 40, HSLAS GRADE 40, HSLAS-F GRADE 40 OR ASTM A666 TYPE 304, 316, 430, OR 201 STAINLESS STEEL (MINIMUM 40 KSI YIELD)



	24 ELMWOOD AVE 1901 S. LITCHFIELD RD MOUNTAINTOP, PA GOODYEAR, AZ	Unless otherwise specified, dimensions are in inches & tolerances are:  0.000 = +/- 0.031 FRACTIONAL = +/- 1/32 ANGLES = +/- 1/2 DEG		
	P: 800.390.8590 F: 866.448.6798 E: ADS@COOKSONDOOR.COM			
TITLE: <b>STORMDEFENDER NON-INSULATED          ROLLING STEEL DOOR 200 PSF 80 FPS</b>	DRAWN BY: <b>TJE</b>	SIZE: <b>B</b>	SCALE: <b>AS NOTED</b>	SHEET: <b>2/7</b>
DWG NO: <b>ES-16-80-TCCI</b>				

L'TR	REVISION	DATE	BY	E.C.O.
*	ORIGINAL ISSUE	10/02/2018	TJE	1853

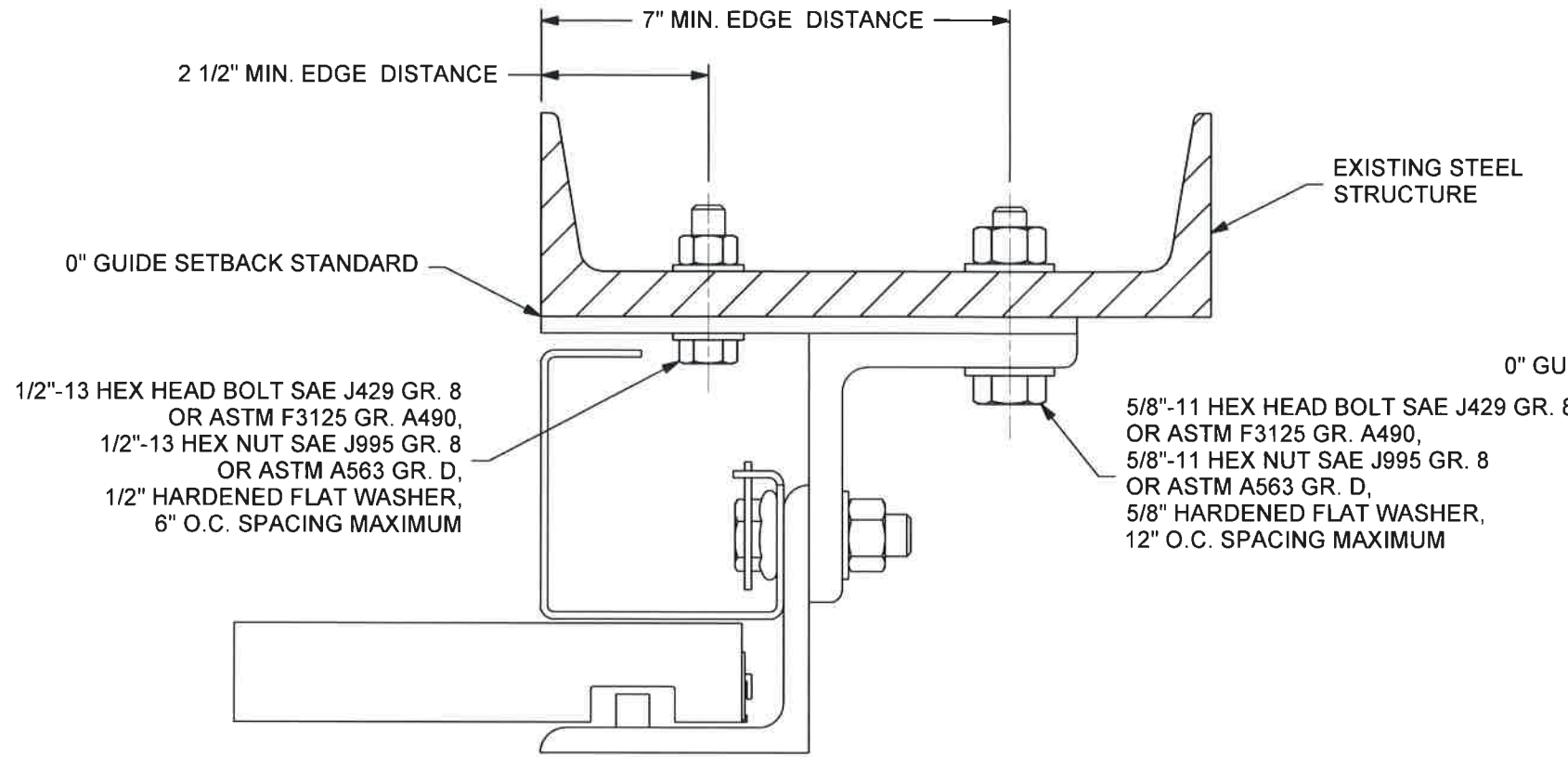

④ GUIDE ASSEMBLY - Z GUIDE BOLTED TO STEEL STRUCTURE  
SCALE 3/8

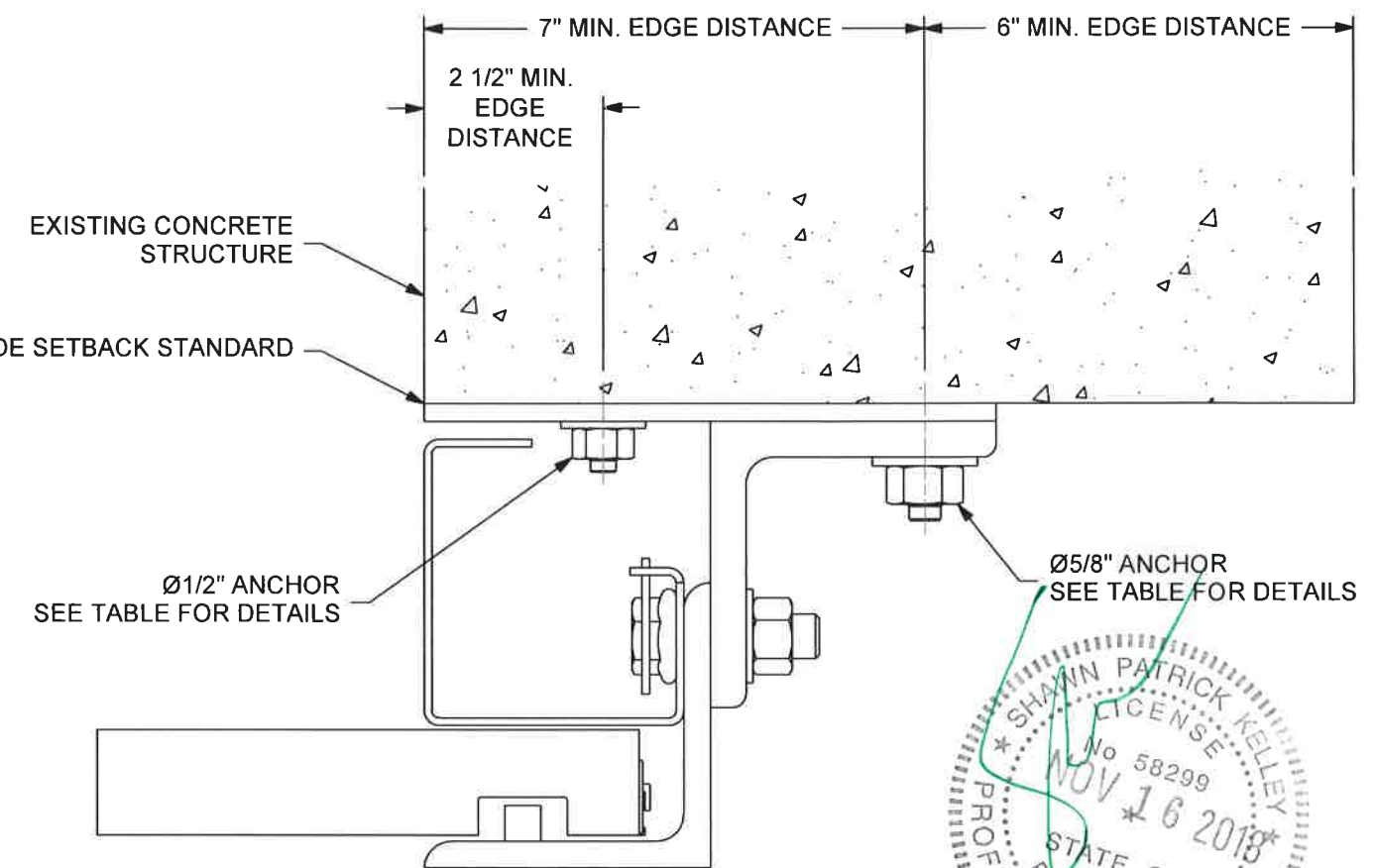

⑤ GUIDE ASSEMBLY - Z GUIDE TO CONCRETE STRUCTURE  
MINIMUM 4,000 PSI CONCRETE & 8" THICK  
SCALE 3/8

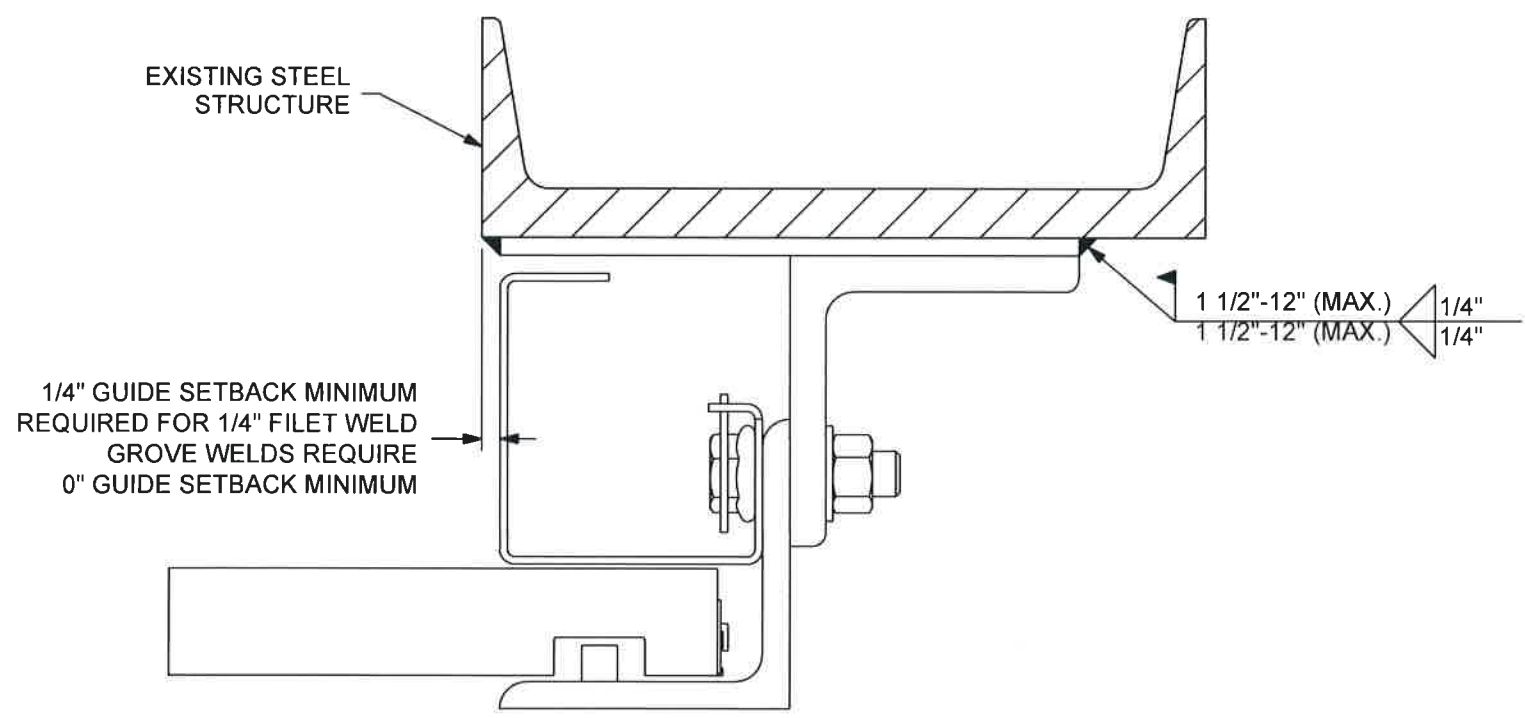
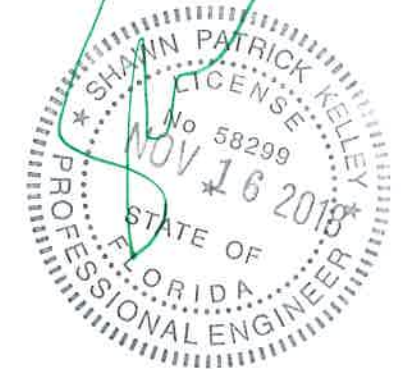

⑥ GUIDE ASSEMBLY - Z GUIDE WELDED TO STEEL STRUCTURE  
SCALE 3/8

ANCHOR DETAILS				
DIAMETER	TYPE	MINIMUM NOMINAL EMBEDMENT DEPTH	MINIMUM EFFECTIVE EMBEDMENT DEPTH	MAXIMUM SPACING
1/2"	HILTI KWIK BOLT TZ CARBON OR STAINLESS STEEL	3 5/8"	3 1/4"	6"
	ITW RED HEAD TRUBOLT+ CARBON STEEL	3 3/4"	3 1/4"	
	HILTI KH-EZ CARBON STEEL	4 1/4"	3.22"	
5/8"	HILTI KWIK BOLT TZ CARBON OR STAINLESS STEEL	4 7/16"	4"	12"
	ITW RED HEAD TRUBOLT+ CARBON STEEL	4 5/8"	4"	
	HILTI KH-EZ CARBON STEEL	5"	3.88"	

	24 ELMWOOD AVE 1901 S. LITCHFIELD RD MOUNTAINTOP, PA GOODYEAR, AZ	Unless otherwise specified, dimensions are in inches & tolerances are:  0.000 = +/- 0.031 FRACTIONAL = +/- 1/32 ANGLES = +/- 1/2 DEG	
	P: 800.390.8590 F: 866.448.6798 E: ADS@COOKSONDOOR.COM	TITLE: <b>STORMDEFENDER NON-INSULATED ROLLING STEEL DOOR 200 PSF 80 FPS</b>	
DRAWN BY: <b>TJE</b>	SIZE: <b>B</b>	SCALE: <b>AS NOTED</b>	SHEET: <b>3/7</b>
DWG NO: <b>ES-16-80-TCCI</b>			

L'TR	REVISION	DATE	BY	E.C.O.
*	ORIGINAL ISSUE	10/02/2018	TJE	1853

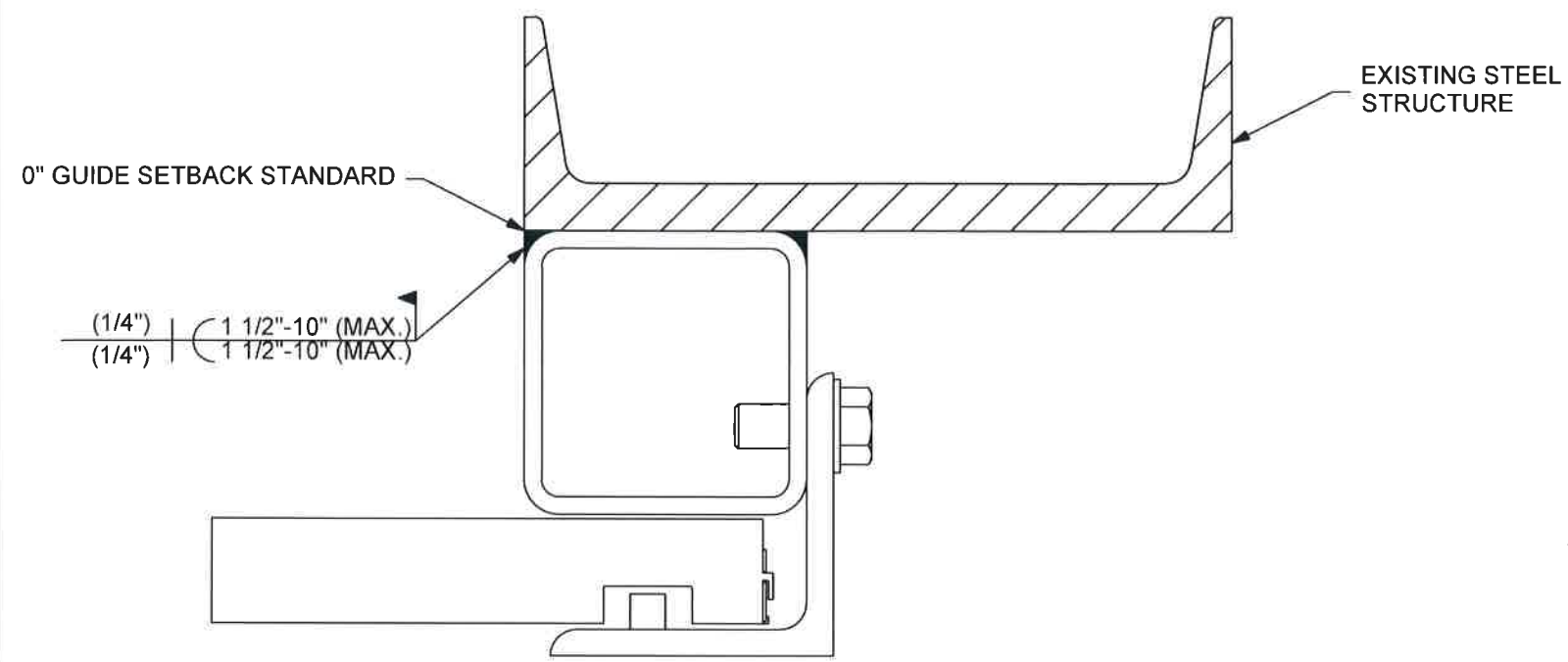

7 GUIDE ASSEMBLY - BOX GUIDE WELDED TO STEEL STRUCTURE  
SCALE 3/8

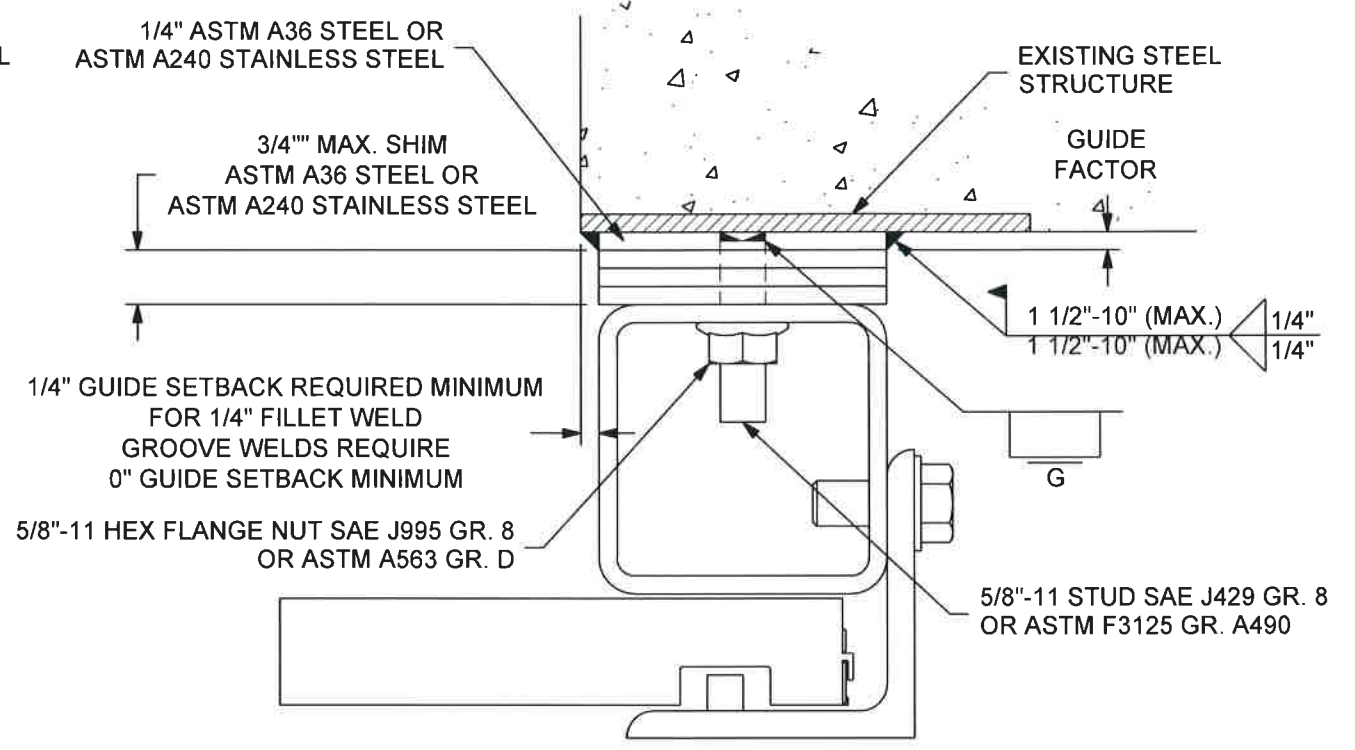

8 GUIDE ASSEMBLY - BOX GUIDE TO STEEL STRUCTURE WITH STUD PLATE  
SCALE 3/8

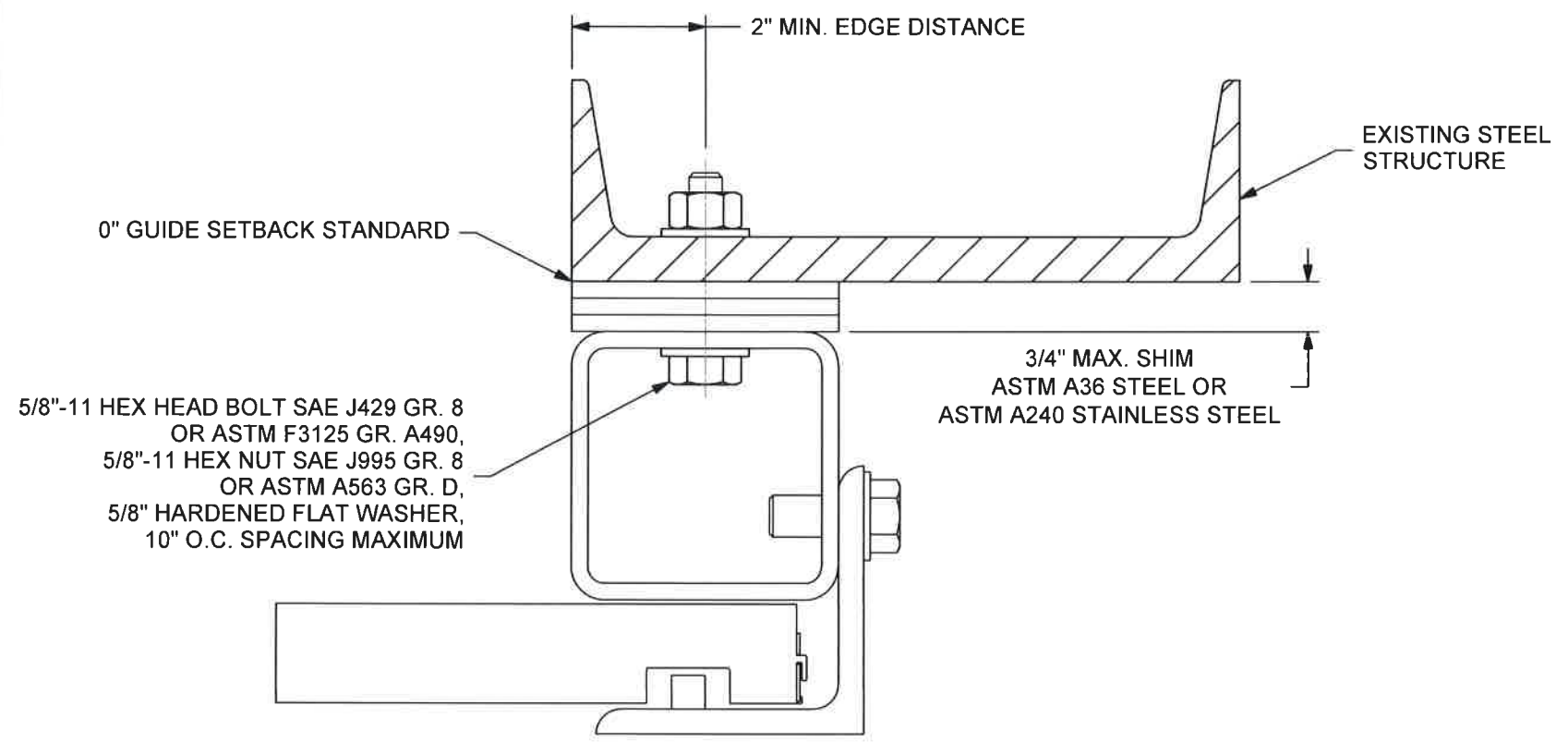

9 GUIDE ASSEMBLY - BOX GUIDE BOLTED TO STEEL STRUCTURE  
SCALE 3/8



	24 ELMWOOD AVE 1901 S. LITCHFIELD RD MOUNTAINTOP, PA GOODYEAR, AZ	Unless otherwise specified, dimensions are in inches & tolerances are:  0.000 = +/- 0.031 FRACTIONAL = +/- 1/32 ANGLES = +/- 1/2 DEG		
	P: 800.390.8590 F: 866.448.6798 E: ADS@COOKSONDOOR.COM			
TITLE: <b>STORMDEFENDER NON-INSULATED          ROLLING STEEL DOOR 200 PSF 80 FPS</b>	DRAWN BY: <b>TJE</b>	SIZE: <b>B</b>	SCALE: <b>AS NOTED</b>	SHEET: <b>4/7</b>
DWG NO: <b>ES-16-80-TCCI</b>				

L'TR	REVISION	DATE	BY	E.C.O.
*	ORIGINAL ISSUE	10/02/2018	TJE	1853

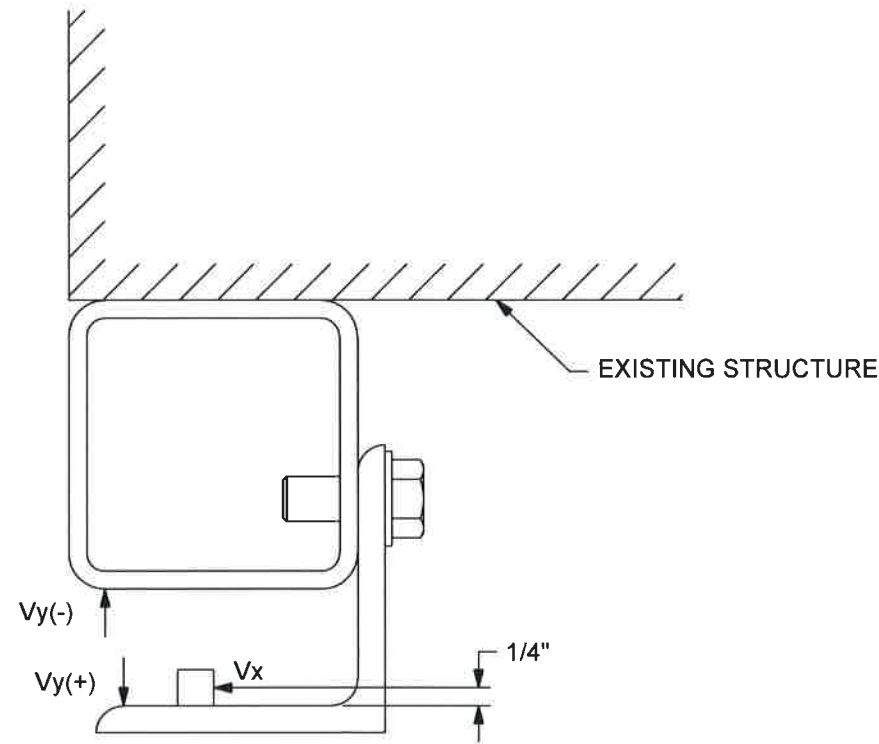

10 SUPERIMPOSED LOAD DIAGRAM - BOX GUIDE  
SCALE 3/8

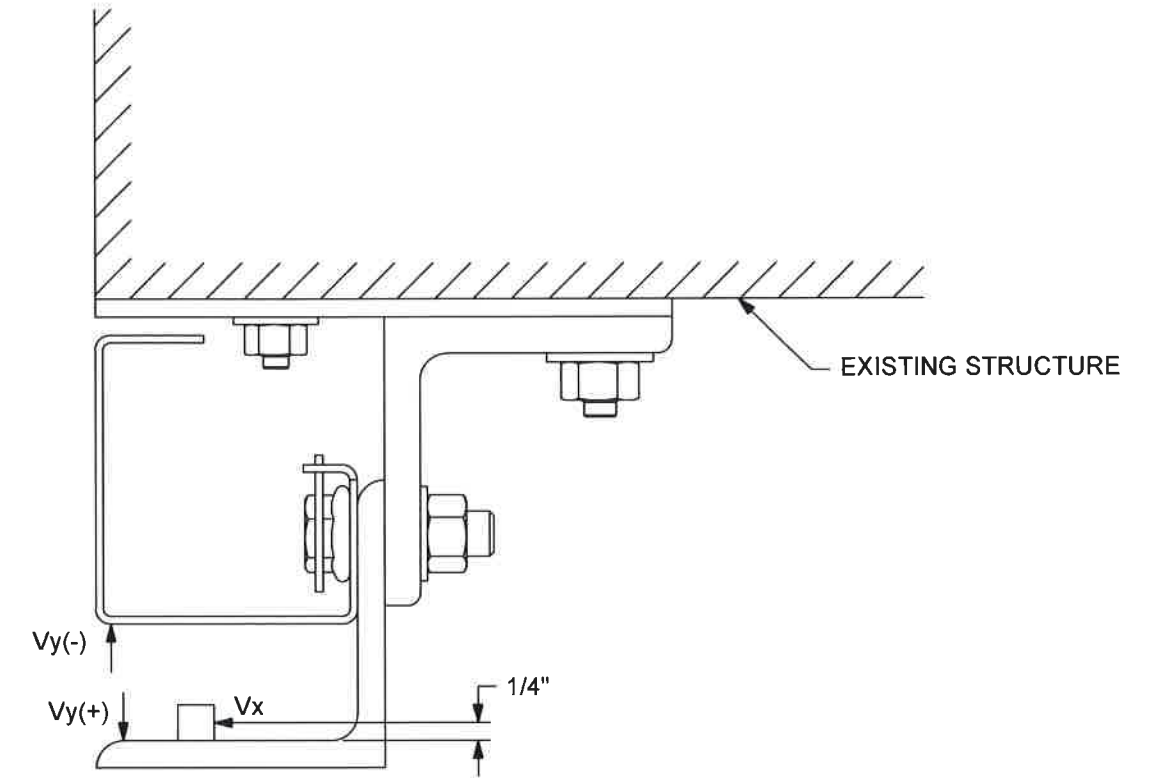

11 SUPERIMPOSED LOAD DIAGRAM - Z GUIDE  
SCALE 3/8

UNREDUCED WIND FORCES (LBS PER FOOT OF HEIGHT)	
Vy(+)	1400
Vy(-)	1400
Vx	0

Vx & Vy ARE THE HORIZ. AND VERT. COMPONENTS OF THE REACTION, RESPECTIVELY, RESULTING FROM WIND LOADS ON THE ROLL-UP DOOR. THE EXISTING STRUCTURE SHALL BE CAPABLE OF RESISTING Vx & Vy FORCES SHOWN AND THE CORRESPONDING REACTIONS DUE TO THE ECCENTRICITIES OF THE FORCES.



	24 ELMWOOD AVE 1901 S. LITCHFIELD RD MOUNTAINTOP, PA GOODYEAR, AZ	Unless otherwise specified, dimensions are in inches & tolerances are:  0.000 = +/- 0.031 FRACTIONAL = +/- 1/32 ANGLES = +/- 1/2 DEG		
	P: 800.390.8590 F: 866.448.6798 E: ADS@COOKSONDOOR.COM			
TITLE: <b>STORMDEFENDER NON-INSULATED          ROLLING STEEL DOOR 200 PSF 80 FPS</b>	DRAWN BY: <b>TJE</b>	SIZE: <b>B</b>	SCALE: <b>AS NOTED</b>	SHEET: <b>5/7</b>
DWG NO: <b>ES-16-80-TCCI</b>				

L'TR	REVISION	DATE	BY	E.C.O.
*	ORIGINAL ISSUE	10/02/2018	TJE	1853

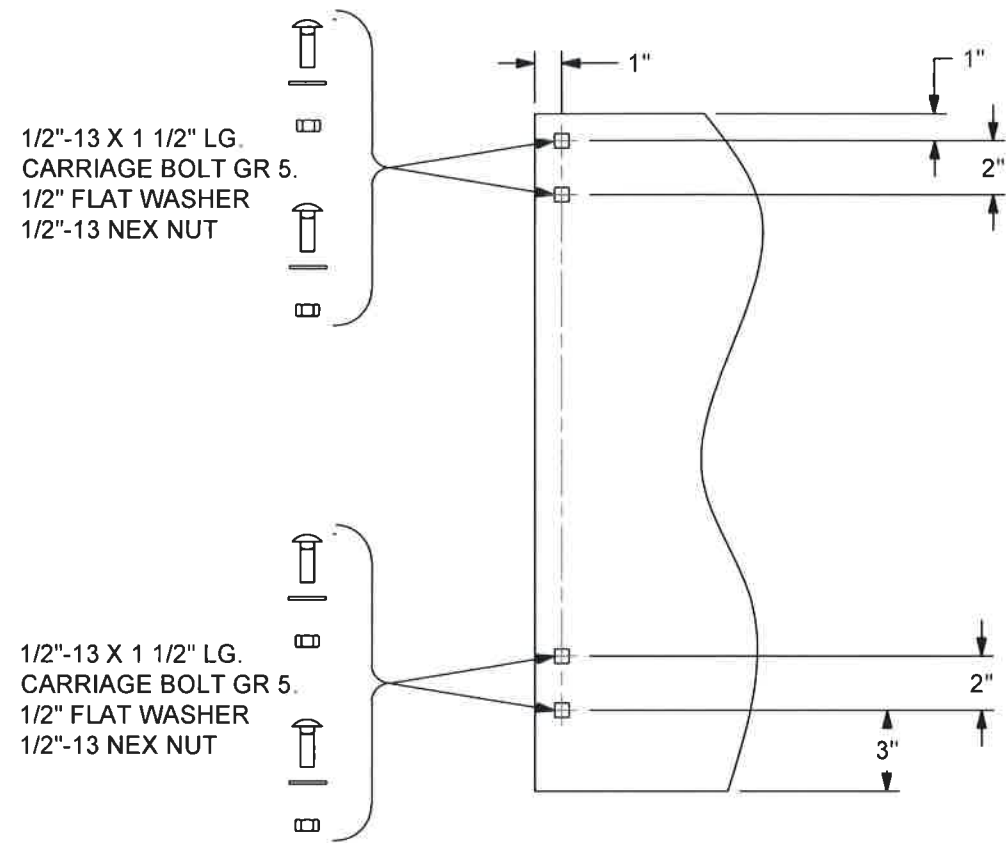

12 BRACKET MOUNTING DETAIL  
0.375 MIN. ASTM A36 STEEL OR  
ASTM A240 STAINLESS STEEL  
SCALE NTS

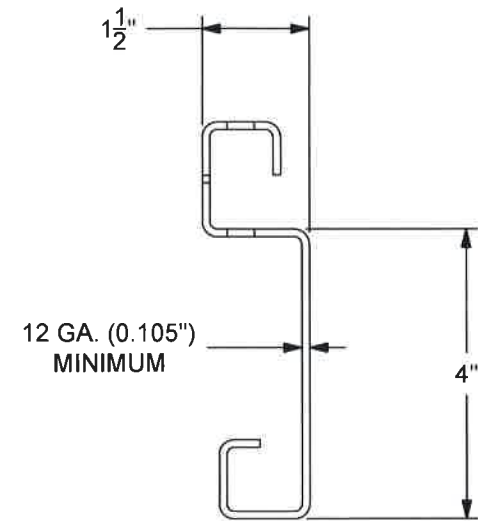

13 SLAT DETAIL  
TYPICAL SECTION  
SEE NOTE 6.1 FOR MATERIAL SPECIFICATIONS  
SCALE 3/8

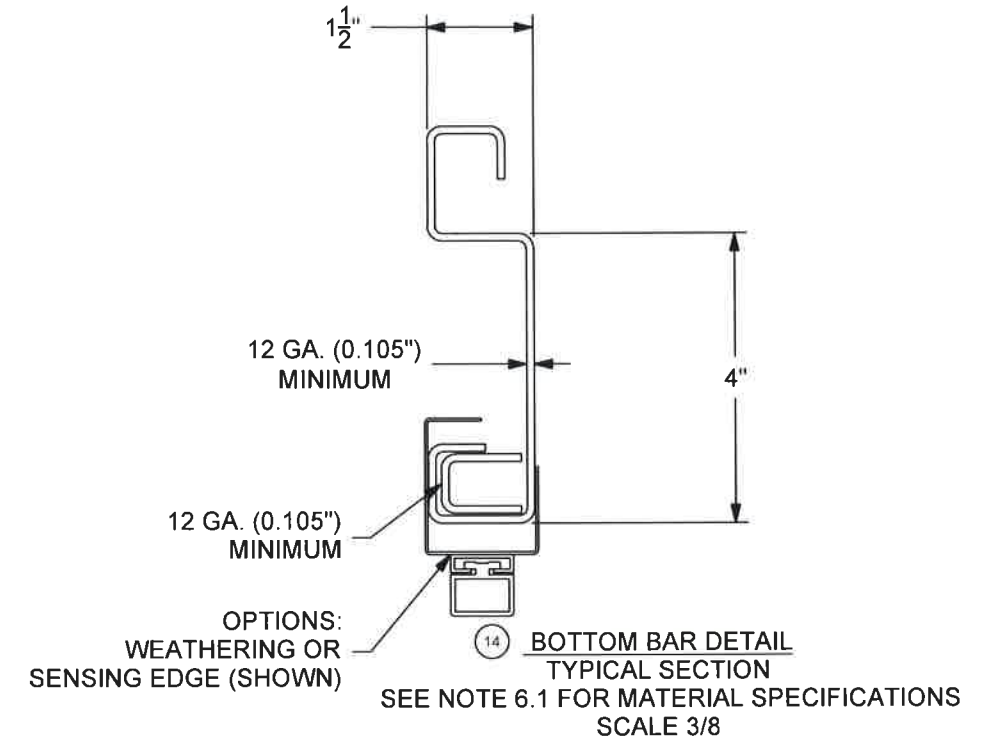

14 BOTTOM BAR DETAIL  
TYPICAL SECTION  
SEE NOTE 6.1 FOR MATERIAL SPECIFICATIONS  
SCALE 3/8

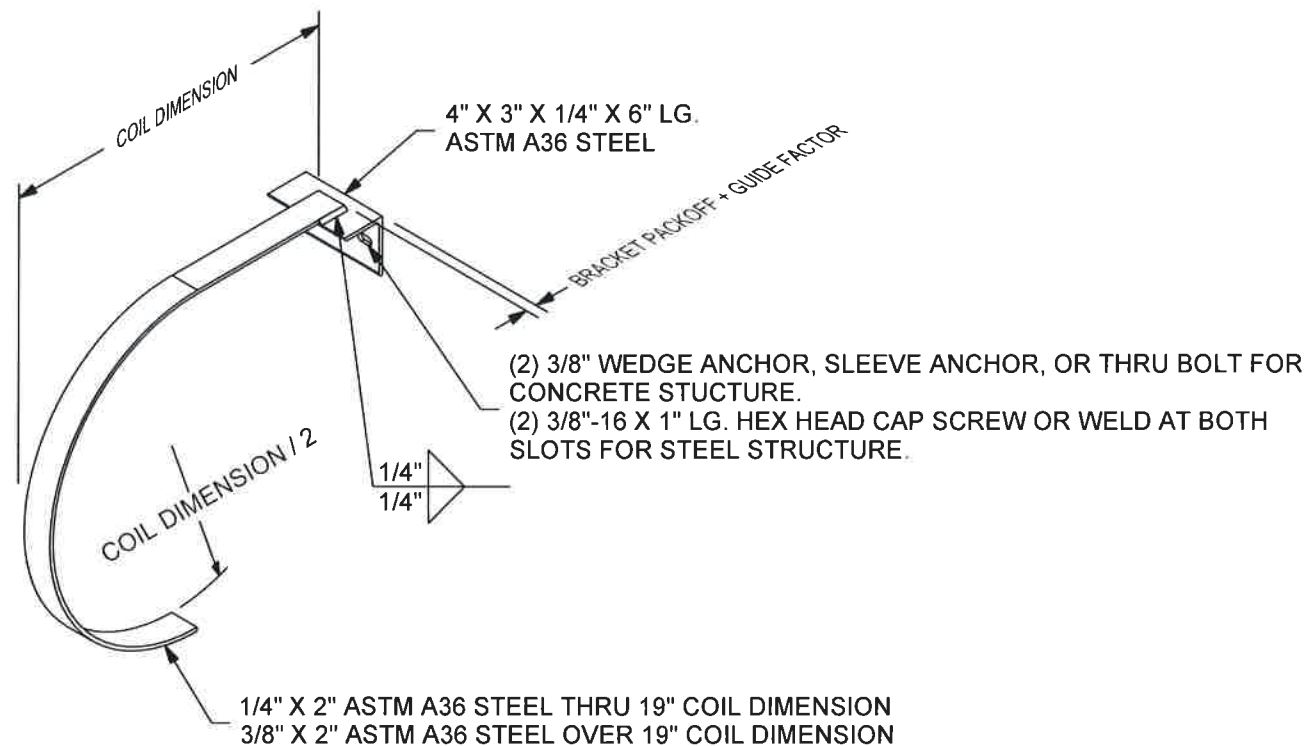

15 MID-HOOD SUPPORT  
(WHEN REQUIRED)  
"D" SHAPE DEPICTED, SQUARE STYLE ALSO AVAILABLE  
SCALE 3/32



NOTES:  
6.1 SHEET MATERIAL: ASTM A1011 CS TYPE B (MINIMUM 40 KSI YIELD), SS GRADE 40, HSLAS GRADE 40, HSLAS-F GRADE 40 OR ASTM A666 TYPE 304, 316, 430, OR 201 STAINLESS STEEL (MINIMUM 40 KSI YIELD)

**COOKSON**  
Preferred door solutions™

24 ELMWOOD AVE 1901 S. LITCHFIELD RD  
MOUNTAINTOP, PA GOODYEAR, AZ  
P: 800.390.8590  
F: 866.448.6798  
E: ADS@COOKSONDOOR.COM

Unless otherwise specified,  
dimensions are in inches &  
tolerances are:  
  
0.000 = +/- 0.031  
FRACTIONAL = +/- 1/32  
ANGLES = +/- 1/2 DEG

TITLE: <b>STORMDEFENDER NON-INSULATED ROLLING STEEL DOOR 200 PSF 80 FPS</b>	DRAWN BY: <b>TJE</b>	SIZE: <b>B</b>	SCALE: <b>AS NOTED</b>	SHEET: <b>6/7</b>
DWG NO: <b>ES-16-80-TCCI</b>				

L'TR	REVISION	DATE	BY	E.C.O.
*	ORIGINAL ISSUE	10/02/2018	TJE	1853

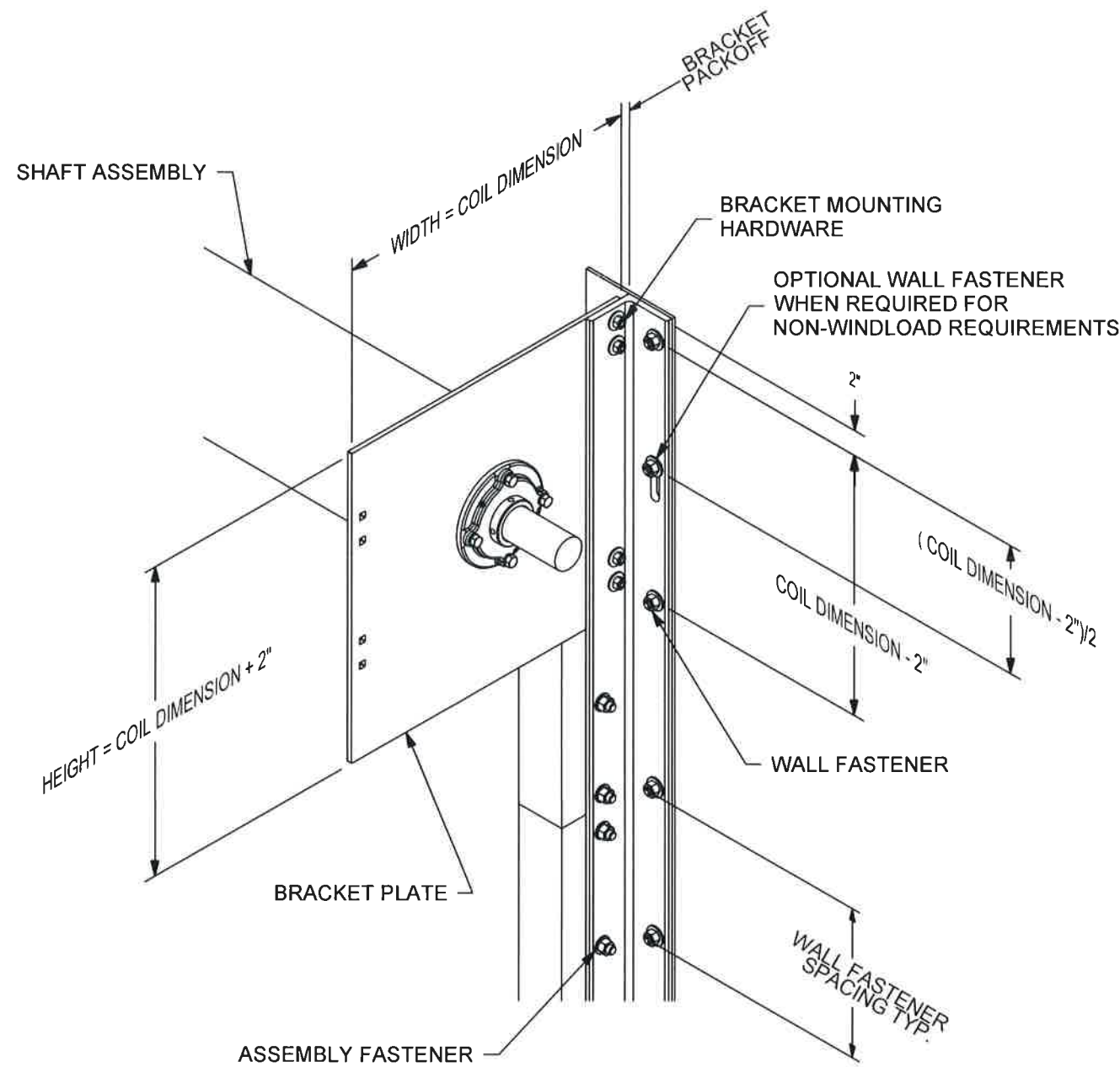

16 BRACKET MOUNTING / TOP WALL ANGLE FASTENING - Z GUIDE  
 BRACKET MOUNTING PER DETAIL 12 DEPICTED  
 OTHER BRACKET MOUNTINGS ARE AVAILABLE  
 HEIGHT AND WIDTH DIMENSION MAY INCREASE  
 FOR OTHER MOUNTING CONFIGURATIONS  
 SCALE NTS

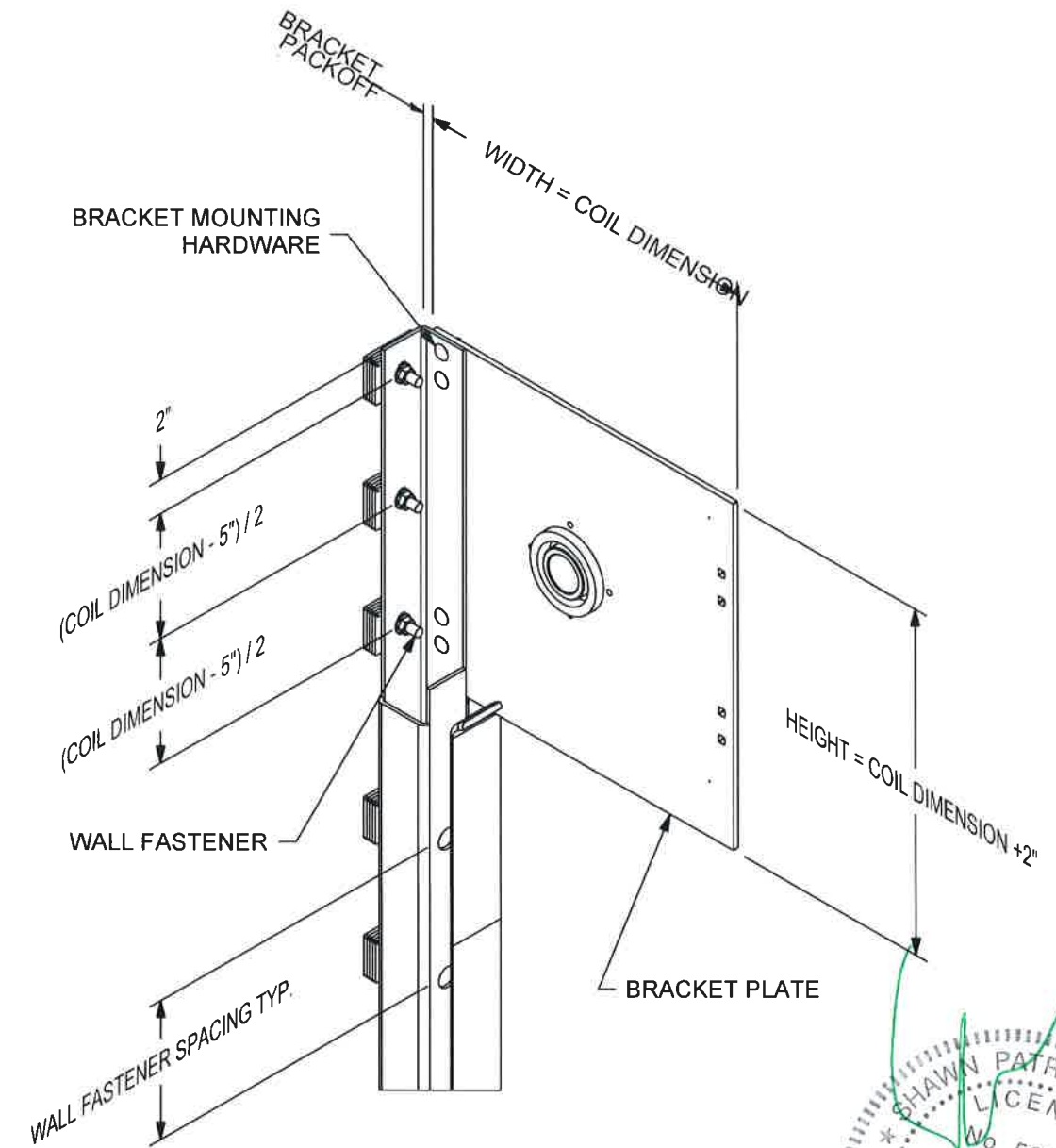

17 BRACKET MOUNTING / TOP TUBE FASTENING - BOX GUIDE  
 BRACKET MOUNTING PER DETAIL 12 DEPICTED  
 OTHER BRACKET MOUNTINGS ARE AVAILABLE  
 HEIGHT AND WIDTH DIMENSION MAY INCREASE  
 FOR OTHER MOUNTING CONFIGURATIONS  
 SHAFT AND ASSEMBLY FASTENERS NOT SHOWN. SEE DETAIL 16  
 SCALE NTS

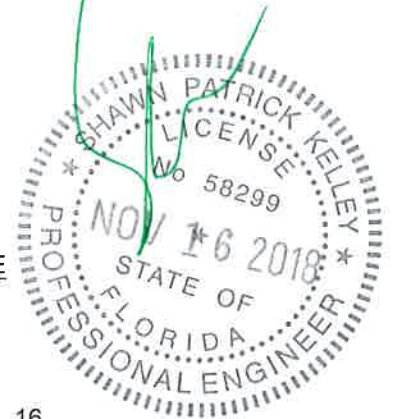

**COOKSON**  
 Preferred door solutions™

24 ELMWOOD AVE 1901 S. LITCHFIELD RD  
 MOUNTAINTOP, PA GOODYEAR, AZ  
 P: 800.390.8590  
 F: 866.448.6798  
 E: ADS@COOKSONDOOR.COM

Unless otherwise specified,  
 dimensions are in inches &  
 tolerances are:  
 0.000 = +/- 0.031  
 FRACTIONAL = +/- 1/32  
 ANGLES = +/- 1/2 DEG

TITLE:	STORMDEFENDER NON-INSULATED ROLLING STEEL DOOR 200 PSF 80 FPS	DRAWN BY:	TJE	SIZE:	B	SCALE:	AS NOTED	SHEET:	7/7
DWG NO:		ES-16-80-TCCI							