



MIAMI-DADE COUNTY
 PRODUCT CONTROL SECTION
 11805 SW 26 Street, Room 208
 Miami, Florida 33175-2474
 T (786) 315-2590 F (786) 315-2599
www.miamidade.gov/economy

DEPARTMENT OF REGULATORY AND ECONOMIC RESOURCES (RER)
 BOARD AND CODE ADMINISTRATION DIVISION
NOTICE OF ACCEPTANCE (NOA)

The Cookson Company
 1901 South Litchfield Road
 Goodyear, AZ 85338

SCOPE:

This NOA is being issued under the applicable rules and regulations governing the use of construction materials. The documentation submitted has been reviewed and accepted by Miami-Dade County RER-Product Control Section to be used in Miami Dade County and other areas where allowed by the Authority Having Jurisdiction (AHJ).

This NOA shall not be valid after the expiration date stated below. The Miami-Dade County Product Control Section (In Miami Dade County) and/or the AHJ (in areas other than Miami Dade County) reserve the right to have this product or material tested for quality assurance purposes. If this product or material fails to perform in the accepted manner, the manufacturer will incur the expense of such testing and the AHJ may immediately revoke, modify, or suspend the use of such product or material within their jurisdiction. RER reserves the right to revoke this acceptance, if it is determined by Miami-Dade County Product Control Section that this product or material fails to meet the requirements of the applicable building code.

This product is approved as described herein, and has been designed to comply with the Florida Building Code, including the High Velocity Hurricane Zone.

DESCRIPTION: Insulated Steel Rolling Door up to 14'-5" Wide (80 FPS Impact)

APPROVAL DOCUMENT: Drawing No. ES-16-57-TCCI, titled "14'-5" Wide 120 PSF 80 FPS Insulated Rolling Steel Door", sheets 1 through 6 of 6, dated 01/06/2015, with revision A dated 05/19/2015, prepared by The Cookson Company, signed and sealed by Joseph H. Dixon, Jr., P.E., bearing the Miami-Dade County Product Control approval stamp with the Notice of Acceptance number and approval date by the Miami-Dade County Product Control Section.

MISSILE IMPACT RATING: Large and Small Missile Impact Resistant

LABELING: A permanent label with the manufacturer's name or logo, one of the 3 manufacturing addresses on drawings, model number, the positive and negative design pressure rating, indicate impact rated if applicable, installation instruction drawing reference number, approval number (NOA), the applicable test standards, and the statement reading 'Miami-Dade County Product Control Approved' is to be located on the door's side track, bottom angle, or inner surface of a panel.

RENEWAL of this NOA shall be considered after a renewal application has been filed and there has been no change in the applicable building code negatively affecting the performance of this product.

TERMINATION of this NOA will occur after the expiration date or if there has been a revision or change in the materials, use, and/or manufacture of the product or process. Misuse of this NOA as an endorsement of any product, for sales, advertising or any other purposes shall automatically terminate this NOA. Failure to comply with any section of this NOA shall be cause for termination and removal of NOA.

ADVERTISEMENT: The NOA number preceded by the words Miami-Dade County, Florida, and followed by the expiration date may be displayed in advertising literature. If any portion of the NOA is displayed, then it shall be done in its entirety.

INSPECTION: A copy of this entire NOA shall be provided to the user by the manufacturer or its distributors and shall be available for inspection at the job site at the request of the Building Official.

This NOA consists of this page 1 and evidence page E-1, as well as approval document mentioned above.

The submitted documentation was reviewed by Carlos M. Utrera, P.E.



Handwritten signature and date: 10/08/2015

NOA No. 15-0318.05
 Expiration Date: July 9, 2020
 Approval Date: July 9, 2015
 Page 1

NOTICE OF ACCEPTANCE: EVIDENCE SUBMITTED

A. DRAWINGS

1. Drawing No. **ES-16-57-TCCI**, titled "14'-5" Wide 120 PSF 80 FPS Insulated Rolling Steel Door", sheets 1 through 6 of 6, dated 01/06/2015, with revision A dated 05/19/2015, prepared by The Cookson Company, signed and sealed by Joseph H. Dixon, Jr., P.E.

B. TESTS

1. Test reports on 1) Uniform Static Air Pressure Test, Loading per FBC, TAS 202-94
2) Large Missile Impact Test per FBC, TAS 201-94 (Level 'E')
3) Cyclic Wind Pressure Loading per FBC, TAS 203-94
4) Forced Entry Test, per FBC, TAS 202-94
5) Tensile Test per ASTM E8-08,
along with marked-up drawings and installation diagram of Thermiser Roll-up Garage Doors, prepared by Intertek/Architectural Testing, Inc., Test Report No. **D1278.02-109-18**, dated 01/29/2014, signed and sealed by Michael D. Stremmel, P.E.
2. Test report on Salt Spray Performance Test per ASTM B117-09 of G90 unpainted and G40 painted samples, prepared by Intertek, Test Report No. **G100075502MID-002**, dated 05/26/2010, signed and sealed by Rick Curkeet, P.E.
3. Test Report on Ignition Temperature per ASTM D1929 and Flame Spread/ Smoke Density per ASTM E84 of polyurethane foam, prepared by ETC Laboratories, Repot # **ETC-07-1071-18738.0**, dated 03/26/2007, signed and sealed by Joseph L. Doldan, P.E.

C. CALCULATIONS

1. Calculations prepared by Joseph H. Dixon, Jr., P.E., dated 02/02/2015, signed and sealed by Joseph H. Dixon, Jr., P.E.

D. QUALITY ASSURANCE

1. Miami-Dade Department of Regulatory and Economic Resources (RER)

E. MATERIAL CERTIFICATIONS

1. None.

F. STATEMENTS

1. Statement letter of code conformance to 2010 and 5th edition (2014) FBC issued by Joseph H. Dixon, Jr., P.E., dated 03/11/2015, signed and sealed by Joseph H. Dixon, Jr., P.E.
2. Statement letter of no financial interest issued by Joseph H. Dixon, Jr., P.E., dated 03/11/2015, signed and sealed by Joseph H. Dixon, Jr., P.E.

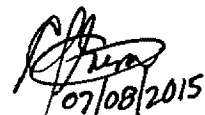

Carlos M. Utrera, P.E.
Product Control Examiner
NOA No. 15-0318.05
Expiration Date: July 9, 2020
Approval Date: July 9, 2015

L/TR	REVISION	DATE	BY	E.C.O.
*	ORIGINAL ISSUE	01/06/15	TJE	1614
A	REVISED NOTES	05/19/15	TJE	1614

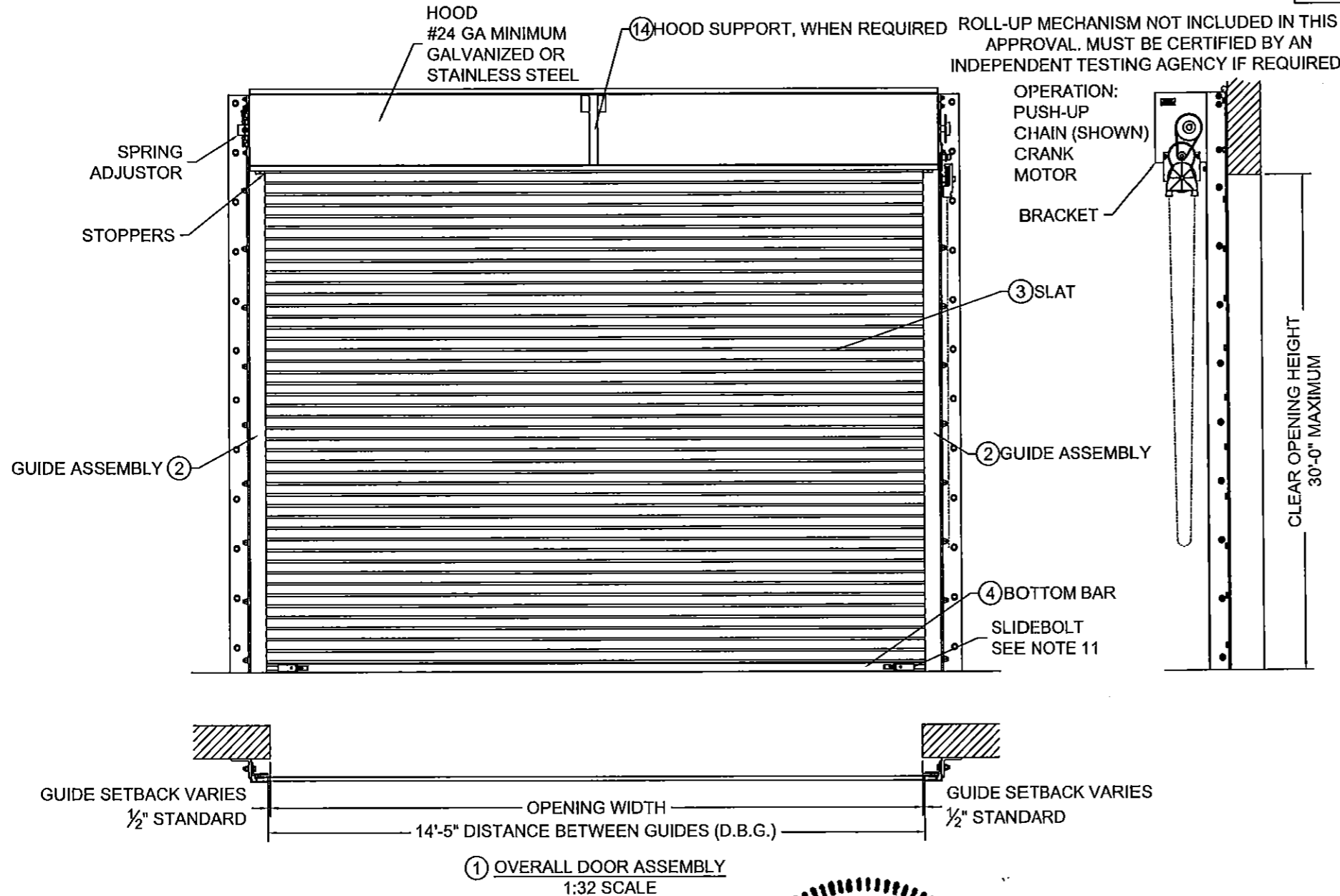

- NOTES:
1. THIS ROLL-UP DOOR SYSTEM IS DESIGNED IN ACCORDANCE WITH THE FLORIDA BUILDING CODE, AS A LARGE MISSILE IMPACT RESISTANT SYSTEM.
 2. POSITIVE AND NEGATIVE DESIGN PRESSURE CALCULATIONS SHALL BE PERFORMED FOR SPECIFIC JOBS IN ACCORDANCE WITH ASCE 7 *MINIMUM DESIGN LOADS FOR BUILDINGS AND OTHER STRUCTURES*. WIND LOADS DETERMINED FOR OPENINGS SHALL BE LESS THAN OR EQUAL TO DOOR DESIGN PRESSURES NOTED BELOW.
POSITIVE DESIGN LOAD = 120 PSF
NEGATIVE DESIGN LOAD = 120 PSF
 3. THE DETAILS AND SPECIFICATIONS SHOWN HEREIN REPRESENT THE PRODUCTS TESTED FOR UNIFORM STATIC AIR PRESSURE IN CONFORMANCE WITH DADE COUNTY PROTOCOLS TAS 201, 202 AND 203.
 4. TESTING PERFORMED BY ARCHITECTURAL TESTING, INC. (YORK, PENNSYLVANIA) TEST REPORT No. D1278.02-109-18.
 5. SUPERIMPOSED LOADS ON THE JAMBS FROM THIS DOOR ARE DESIGNATED AS F1, F2, AND F3 HEREIN. CONTRACTORS SHALL HAVE FLORIDA REGISTERED PROFESSIONAL ENGINEER VERIFY ADEQUACY OF BUILDING STRUCTURE TO RESIST SUPERIMPOSED LOAD F1, F2, AND F3.
 6. ALL WELDING SHALL BE PERFORMED BY QUALIFIED WELDERS IN ACCORDANCE WITH AWS SPECIFICATIONS, LATEST EDITION. ALL WELDING ELECTRODES SHALL CONFORM TO AWS A5.1, GRADE E-70. MINIMUM WELDING PROCESS SHALL BE ARC WELDING AWS E7014 OR MIG WELDING AWS ER70S-6.
 7. ANCHOR NOTES:
A. EMBEDMENT DEPTH DOES NOT INCLUDE STUCCO FINISH.
B. ANCHORS SHALL BE INSTALLED IN ACCORDANCE WITH MANUFACTURERS SPECIFICATIONS.
 8. FOAMED IN PLACE INSULATION, TESTED IN ACCORDANCE WITH ASTM E-84 AND D-1929 OR MINERAL WOOL INSULATION.
 9. DOOR MAY BE INSTALLED ON THE INSIDE OR OUTSIDE OF AN EXTERIOR WALL.
 10. A 33% INCREASE IN ALLOWABLE STRESS HAS NOT BEEN USED IN THE DESIGN OF THIS PRODUCT.
 11. SLIDE BOLTS ARE NOT REQUIRED FOR WINDLOAD RESISTANCE. SLIDE BOLTS ARE ONLY REQUIRED ON PUSH UP OPERATED UNITS FOR FORCED ENTRY RESISTANCE. LOCKING IS TO BE PROVIDED BY OTHERS OR AS CYLINDER LOCKS BY CORNELL IRON WORKS.
 12. ENDLOCK/WINDLOCKS AND WINDLOCKS ARE SECURED TO EACH END OF ALTERNATING SLAT WITH (3) 1/4" RIVETS PER END RESULTING IN CONTINUOUS SLAT WINDLOCK SUPPORT.
 13. GUIDE ASSEMBLY AND BOTTOM BAR ARE TO BE PROTECTED FROM CORROSION WITH POLYESTER POWDER COATING WHEN NOT MINIMUM G90 GALVANIZED STEEL OR STAINLESS STEEL.

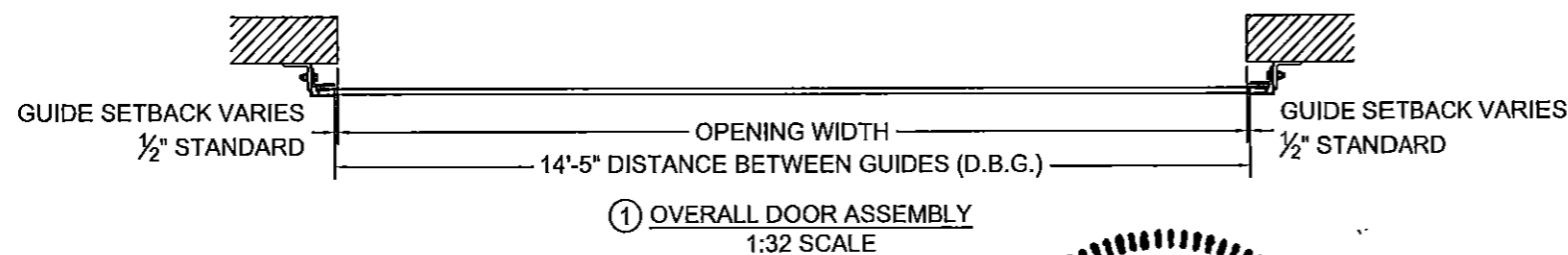

Approved as complying with the
Florida Building Code
Date 07/09/2015
NO. 15-0318.05
Miami Dade Product Control
By *[Signature]*

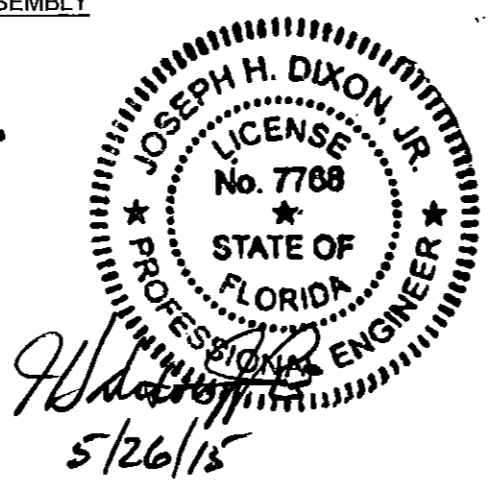

 COOKSON <small>THE COOKSON COMPANY, INC.</small>	24 ELMWOOD AVE 1901 S. LITCHFIELD RD MOUNTAINTOP, PA GOODYEAR, AZ 800 TULIP DRIVE GASTONIA, NC P: 800.390.8590 F: 866.448.6798 E: ADS@COOKSONDOOR.COM	Unless otherwise specified, dimensions are in inches & tolerances are: 0.000 = +/- 0.031 FRACTIONAL = +/- 1/32 ANGLES = +/- 1/2 DEG
	MIAMI DADE COUNTY APPROVED 14'-5" WIDE 120 PSF 80 FPS INSULATED ROLLING STEEL DOOR	
DRAWN BY: TJE		SIZE: B
DWG NO: ES-16-57-TCCI		SCALE: AS NOTED
		SHEET: 1/6

L'TR	REVISION	DATE	BY	E.C.O.
*	ORIGINAL ISSUE	1/06/15	TJE	1614
A	REVISED NOTES	05/19/15	TJE	1614

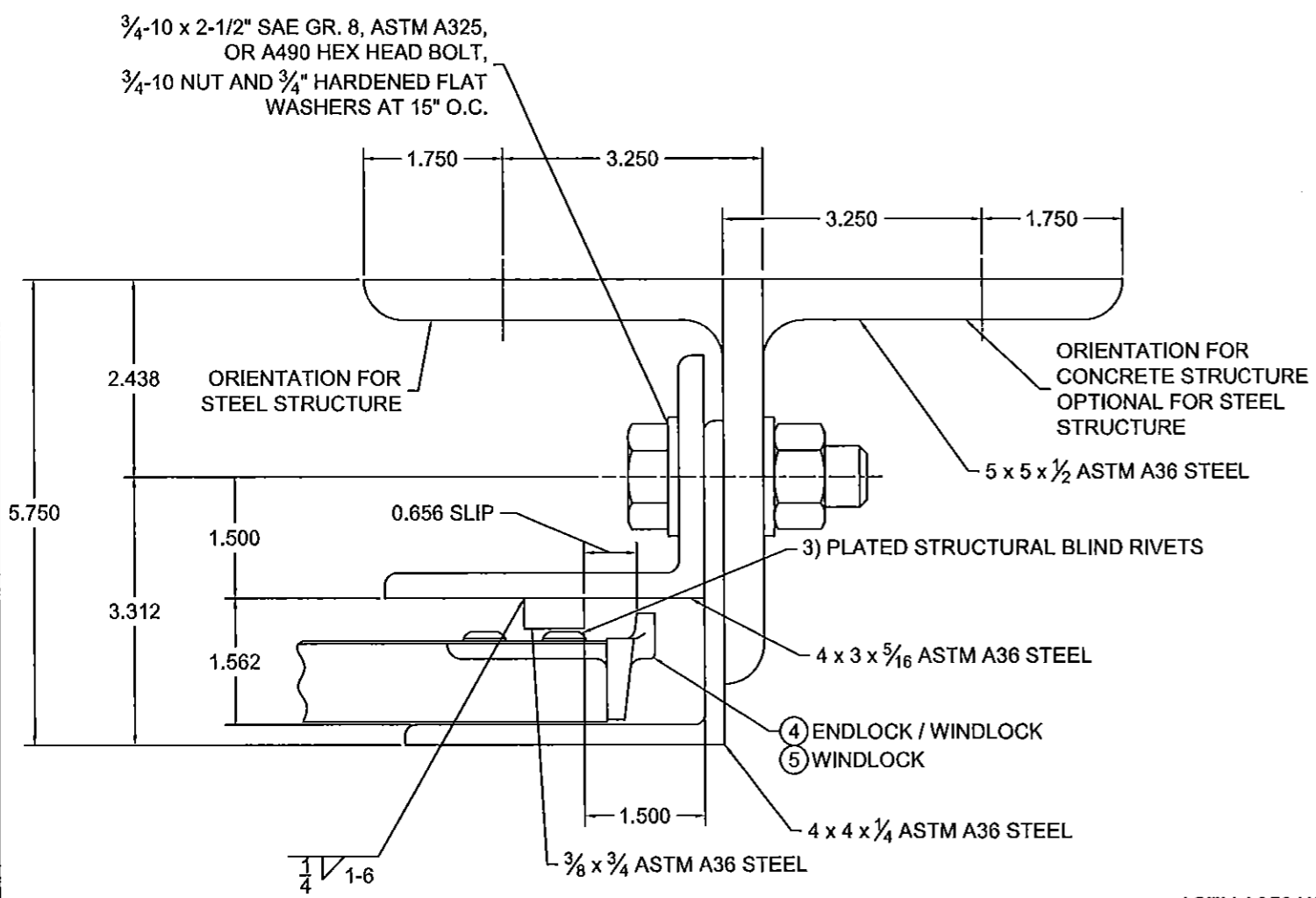

② GUIDE ASSEMBLY DETAIL
1:2 SCALE

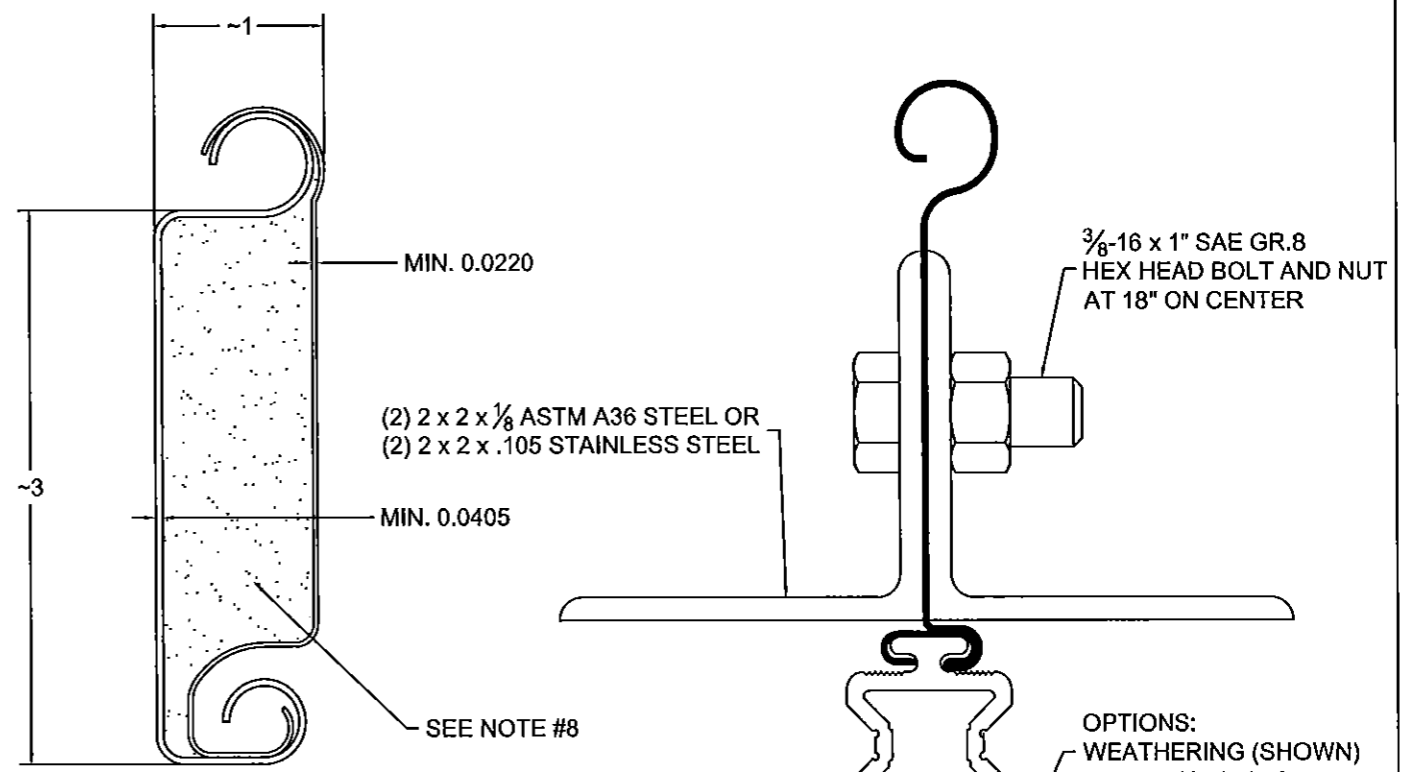



③ SLAT DETAIL
TYPICAL SECTION

ASTM A653 HSLAS TYPE B GRADE 40 G40 WITH POLYESTER BASED COATING OR
 ASTM A653 HSLAS TYPE A GRADE 40 G40 WITH POLYESTER BASED COATING OR
 ASTM A653 STRUCTURAL STEEL GRADE 40 G40 WITH POLYESTER BASED COATING
 OR TYPE 304 STAINLESS STEEL (MIN. YIELD 40,000 psi)
 OR TYPE 316 STAINLESS STEEL (MIN. YIELD 40,000 psi)
 OR TYPE 430 STAINLESS STEEL (MIN. YIELD 40,000 psi)
 OR TYPE 201 STAINLESS STEEL (MIN. YIELD 40,000 psi)
 FULL SCALE

④ BOTTOM BAR DETAIL
TYPICAL SECTION
FULL SCALE

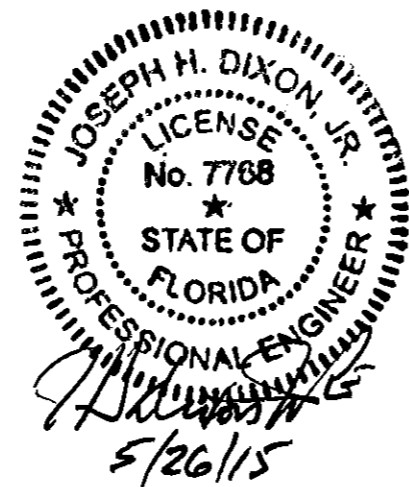
Approved as complying with the
 Florida Building Code
 Date: 07/09/2015
 NOAR 15-0310-05
 Miami Dade Product Control
 By: *[Signature]*



 THE COOKSON COMPANY, INC.	24 ELMWOOD AVE 1901 S. LITCHFIELD RD MOUNTAINTOP, PA GOODYEAR, AZ 800 TULIP DRIVE GASTONIA, NC P: 800.390.8590 F: 866.448.6798 E: ADS@COOKSONDOOR.COM	Unless otherwise specified, dimensions are in inches & tolerances are: 0.000 = +/- 0.031 FRACTIONAL = +/- 1/32 ANGLES = +/- 1/2 DEG			
		TITLE: MIAMI DADE COUNTY APPROVED 14'-5" WIDE 120 PSF 80 FPS INSULATED ROLLING STEEL DOOR	DRAWN BY: TJE	SIZE: B	SCALE: AS NOTED
DWG NO: ES-16-57-TCCI					

L'TR	REVISION	DATE	BY	E.C.O.
*	ORIGINAL ISSUE	1/06/15	TJE	1614
A	REVISED NOTES	05/19/15	TJE	1614

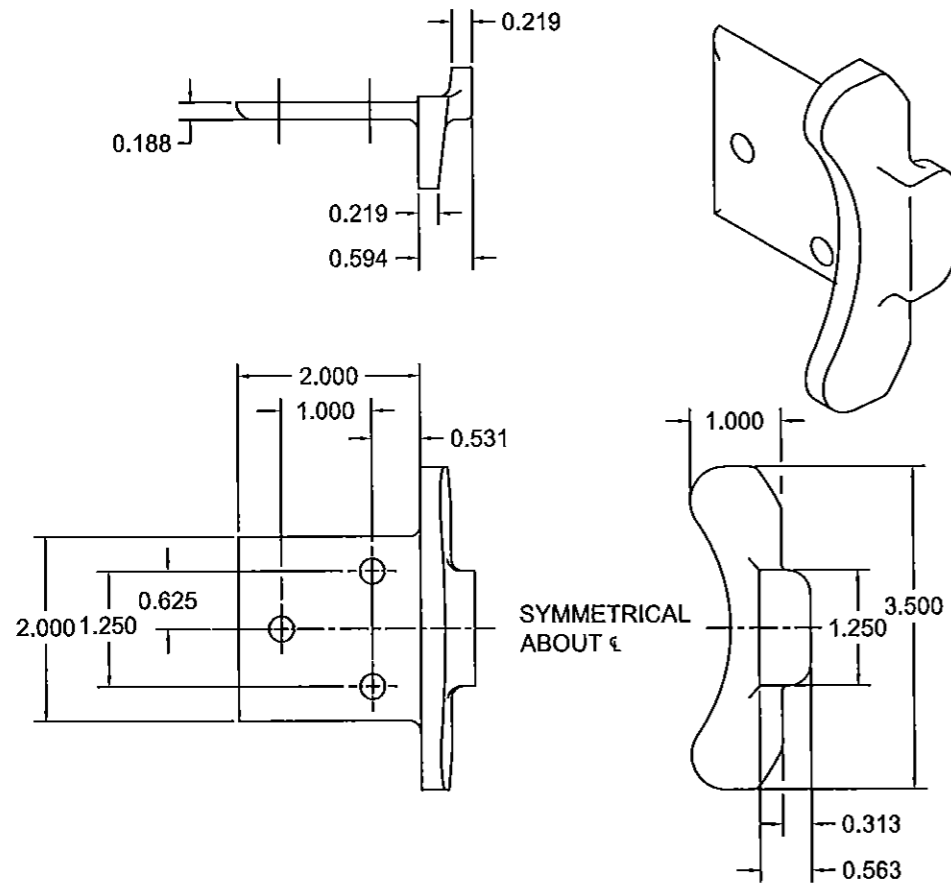

⑤ ENDLOCK / WINDLOCK DETAIL
 CAST MALLEABLE IRON ASTM A47, GRADE 32510, OR
 DUCTILE IRON PER ASTM A536 GRADE 65-45-12, GALVANIZED IN ACCORDANCE WITH
 ASTM A123, GRADE 85 ZINC-COATING
 1/2 SCALE

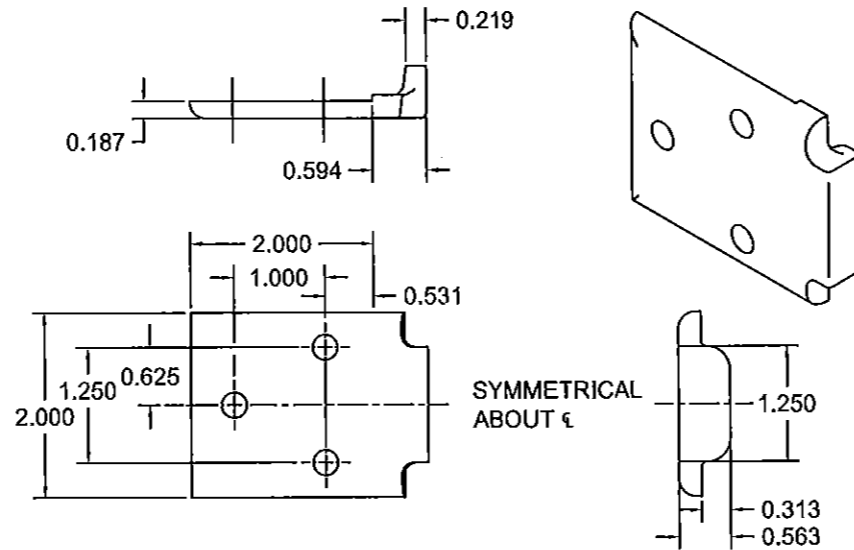

⑥ WINDLOCK DETAIL
 CAST MALLEABLE IRON ASTM A47, GRADE 32510, OR
 DUCTILE IRON PER ASTM A536 GRADE 65-45-12, GALVANIZED IN
 ACCORDANCE WITH ASTM A123, GRADE 85 ZINC-COATING
 1/2 SCALE

1/2-13 x 1 1/2"
 CARRIAGE BOLT GR.5
 1/2" FLAT WASHER
 1/2-13 HEX NUT

1/2-13 x 1 1/2"
 CARRIAGE BOLT GR.5
 1/2" FLAT WASHER
 1/2-13 HEX NUT
 THIS FASTENER ON 17"
 AND LARGER COILS

1/2-13 x 1 1/2"
 CARRIAGE BOLT GR.5
 1/2" FLAT WASHER
 1/2-13 HEX NUT

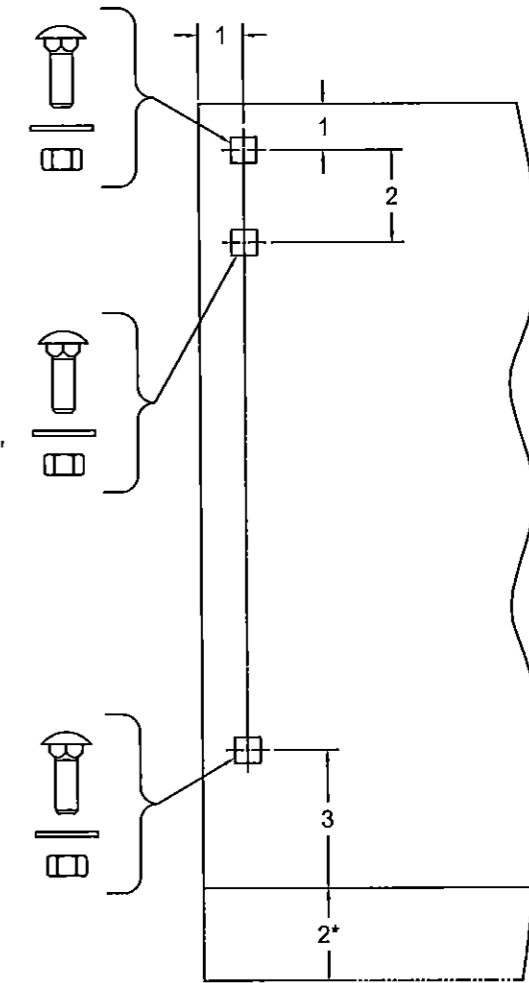

⑦ BRACKET MOUNTING DETAIL
 0.172 MIN. THICKNESS

* 2" EXTENSION WHEN 8" AND LARGER SHAFT ASSEMBLY IS SUPPLIED
 1/4 SCALE

Approved as complying with the
 Florida Building Code
 Date 07/09/2015
 NOAH 15-2310-05
 Miami Dade Product Control
 By *[Signature]*

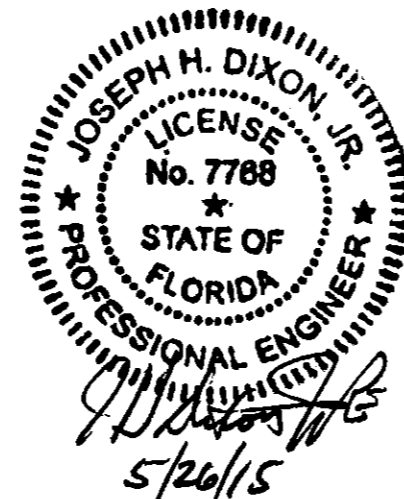

 COOKSON THE COOKSON COMPANY, INC.	24 ELMWOOD AVE 1901 S. LITCHFIELD RD MOUNTAINTOP, PA GOODYEAR, AZ 800 TULIP DRIVE GASTONIA, NC P: 800.390.8590 F: 866.448.6798 E: ADS@COOKSONDOOR.COM	Unless otherwise specified, dimensions are in inches & tolerances are: 0.000 = +/- 0.031 FRACTIONAL = +/- 1/32 ANGLES = +/- 1/2 DEG			
		TITLE: MIAMI DADE COUNTY APPROVED 14'-5" WIDE 120 PSF 80 FPS INSULATED ROLLING STEEL DOOR	DRAWN BY: TJE	SIZE: B	SCALE: AS NOTED
DWG NO: ES-16-57-TCCI					

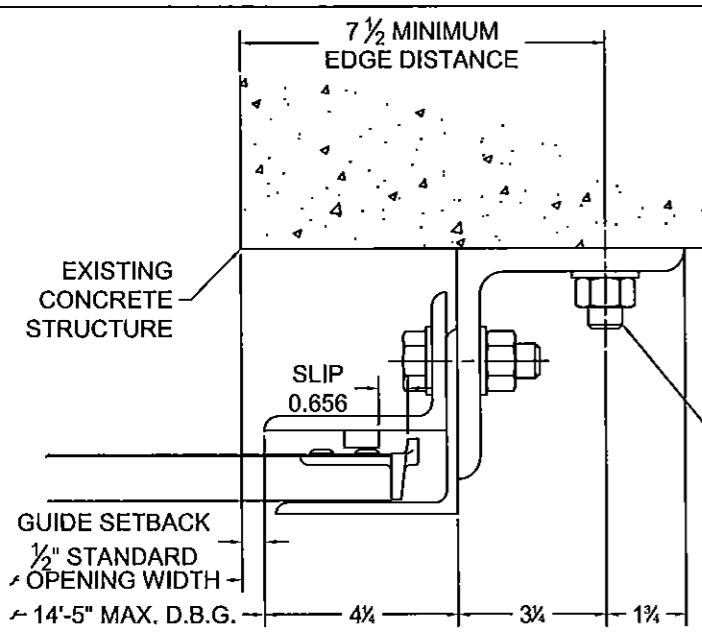

CONCRETE FASTENER SPACING			
CONCRETE STRENGTH (psi)	MAXIMUM FASTENER SPACING (in.)		
	HILTI	SIMPSON	ITW REDHEAD
2000	5	5	*
3000	8	8	7 1/2
4000	11	9 1/2	11

3/4" HILTI KWIK BOLT 3
 4-3/4" MIN. EMBEDMENT
 OR
 3/4" SIMPSON WEDGE-ALL
 5" MIN. EMBEDMENT
 OR
 3/4" ITW REDHEAD TRU-BOLT
 6-5/8" MIN. EMBEDMENT
 (SEE TABLE FOR SPACING)

⑧ GUIDE ASSEMBLY
CONCRETE STRUCTURE
(Z-GUIDE)

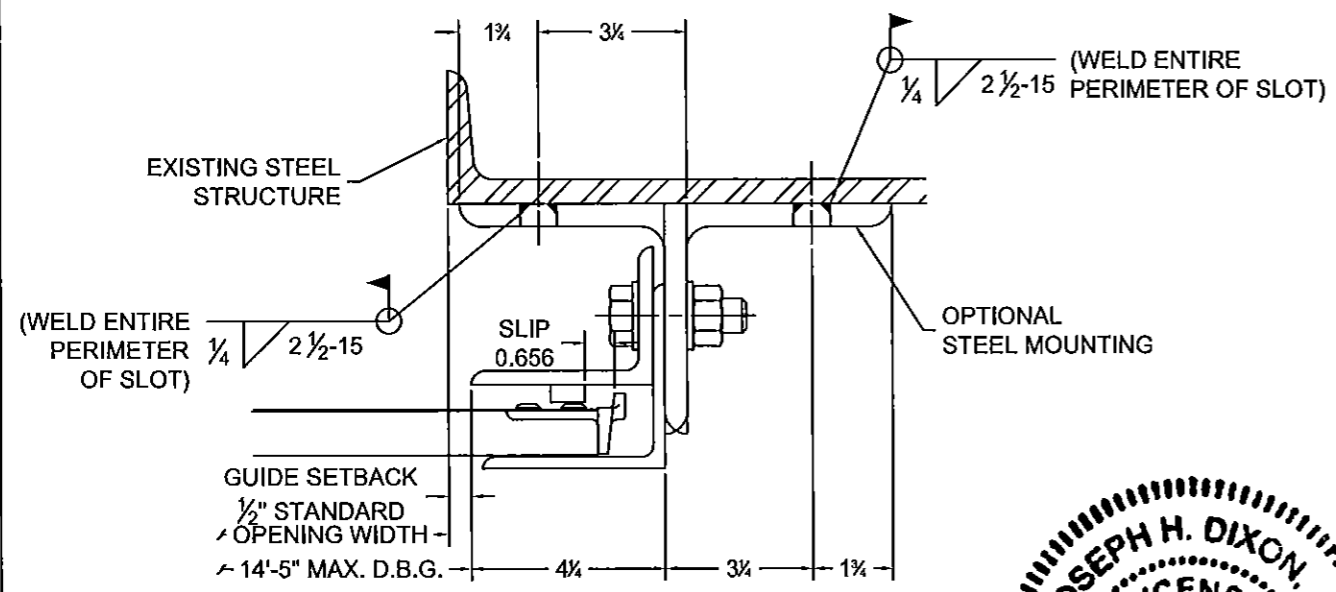

⑩ GUIDE ASSEMBLY
STEEL STRUCTURE
(Z-GUIDE OR E-GUIDE)

Approved as complying with the
 Florida Building Code
 Date 07/09/2015
 NOA# 15-0318-05
 Miami Dade Product Control
 By *[Signature]*

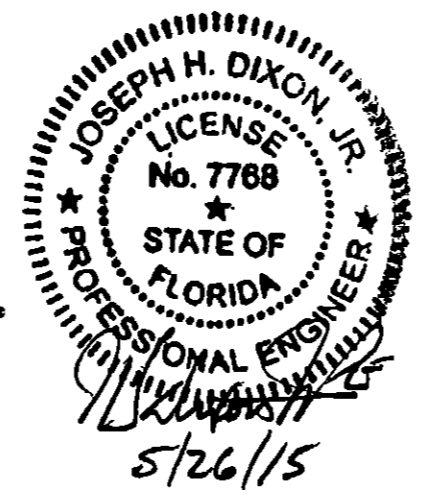

L/TR	REVISION	DATE	BY	E.C.O.
*	ORIGINAL ISSUE	1/06/15	TJE	1614
A	REVISED NOTES	05/19/15	TJE	1614

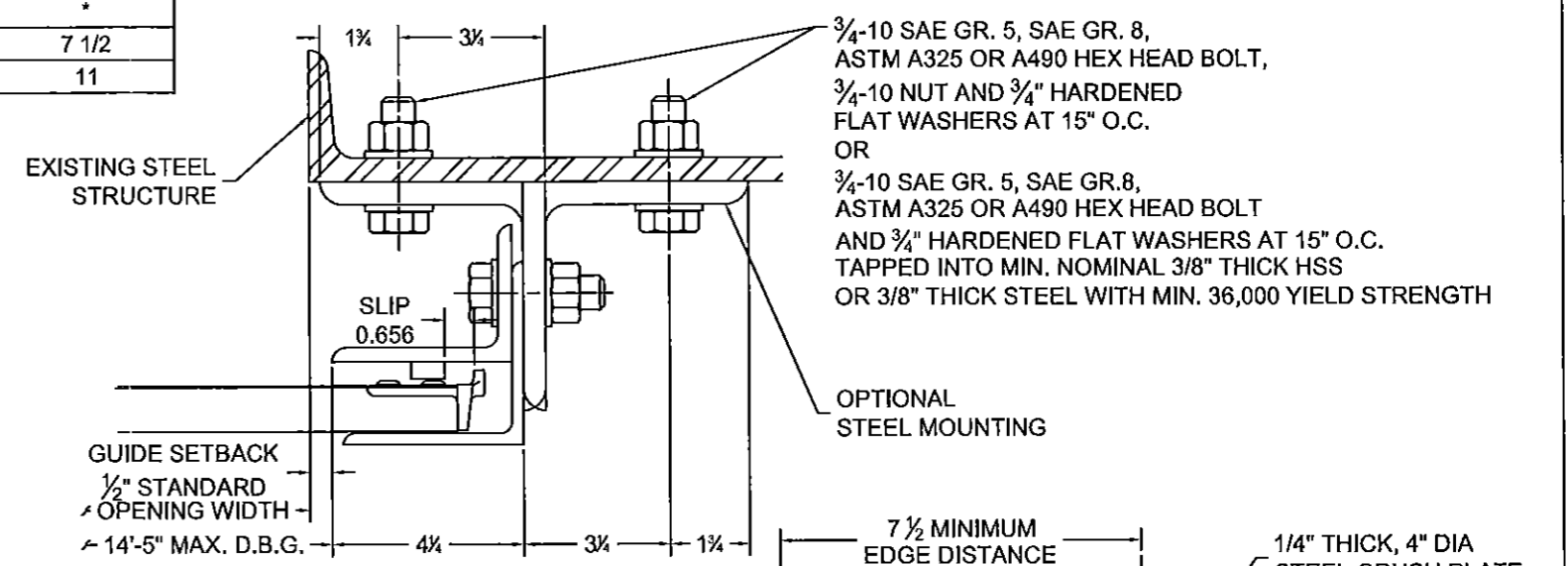

⑨ GUIDE ASSEMBLY
STEEL STRUCTURE
(Z-GUIDE OR E-GUIDE)

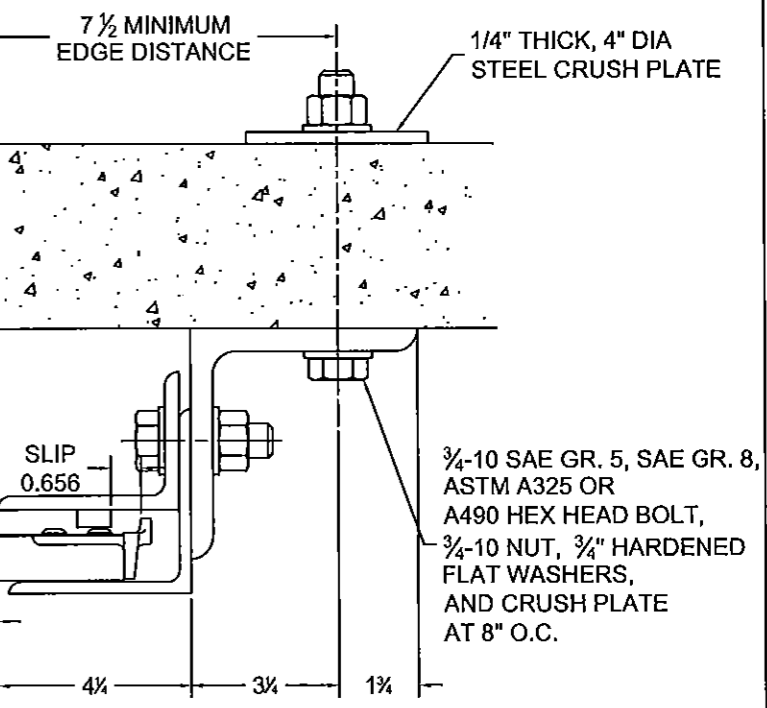

⑪ GUIDE ASSEMBLY
FILLED BLOCK STRUCTURE
(Z-GUIDE)

 COOKSON THE COOKSON COMPANY, INC.	24 ELMWOOD AVE 1901 S. LITCHFIELD RD MOUNTAINTOP, PA GOODYEAR, AZ 800 TULIP DRIVE GASTONIA, NC P: 800.390.8590 F: 866.448.6798 E: ADS@COOKSONDOOR.COM	Unless otherwise specified, dimensions are in inches & tolerances are: 0.000 = +/- 0.031 FRACTIONAL = +/- 1/32 ANGLES = +/- 1/2 DEG
	TITLE: MIAMI DADE COUNTY APPROVED 14'-5" WIDE 120 PSF 80 FPS INSULATED ROLLING STEEL DOOR	DRAWN BY: TJE DWG NO: ES-16-57-TCCI

L'TR	REVISION	DATE	BY	E.C.O.
*	ORIGINAL ISSUE	1/06/15	TJE	1614
A	REVISED NOTES	05/19/15	TJE	1614

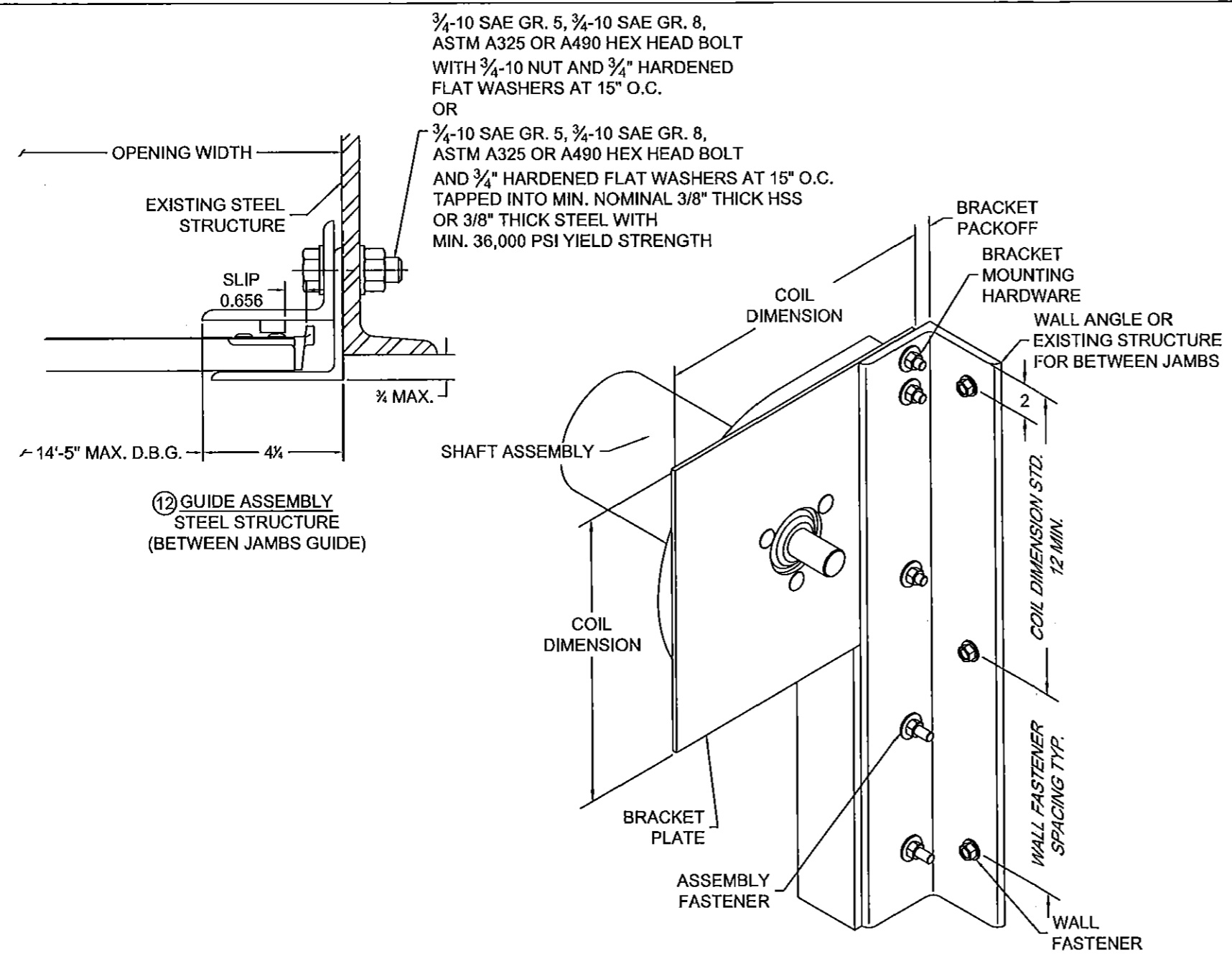

⑫ GUIDE ASSEMBLY
STEEL STRUCTURE
(BETWEEN JAMBS GUIDE)

⑬ BRACKET MOUNTING / TOP WALL ANGLE FASTENING
BRACKET MOUNTING PER DETAIL 7 DEPICTED,
OTHER BRACKET MOUNTINGS ARE AVAILABLE
SCALE: NTS

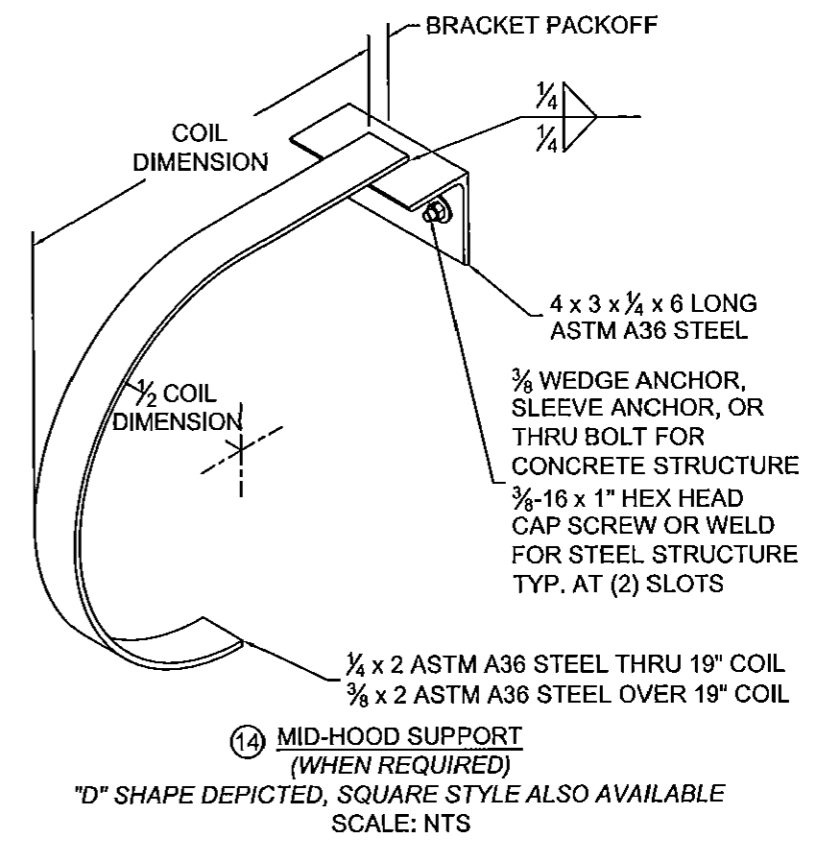

⑭ MID-HOOD SUPPORT
(WHEN REQUIRED)

"D" SHAPE DEPICTED, SQUARE STYLE ALSO AVAILABLE
SCALE: NTS

Approved as complying with the
Florida Building Code
Date: 07/09/2015
NOAR 15-0318-05
Miami Dade Product Control
By: *[Signature]*

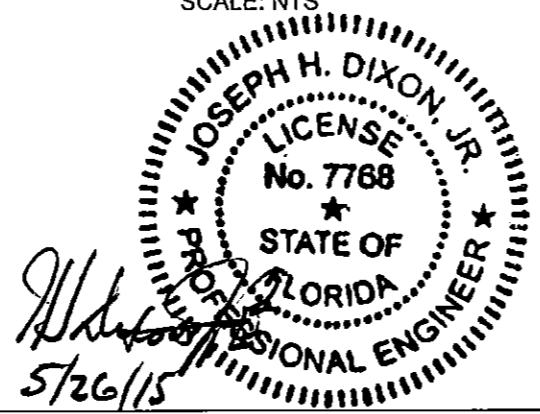

<p>COOKSON THE COOKSON COMPANY, INC.</p>	24 ELMWOOD AVE 1901 S. LITCHFIELD RD MOUNTAINTOP, PA GOODYEAR, AZ 800 TULIP DRIVE GASTONIA, NC P: 800.390.8590 F: 866.448.6798 E: ADS@COOKSONDOOR.COM	Unless otherwise specified, dimensions are in inches & tolerances are: 0.000 = +/- 0.031 FRACTIONAL = +/- 1/32 ANGLES = +/- 1/2 DEG
	TITLE: MIAMI DADE COUNTY APPROVED 14'-5" WIDE 120 PSF 80 FPS INSULATED ROLLING STEEL DOOR	
DRAWN BY: TJE DWG NO: ES-16-57-TCCI		SIZE: B SCALE: AS NOTED SHEET: 5/6

L'TR	REVISION	DATE	BY	E.C.O.
*	ORIGINAL ISSUE	1/6/15	TJE	1614
A	REVISED NOTES	05/19/15	TJE	1614

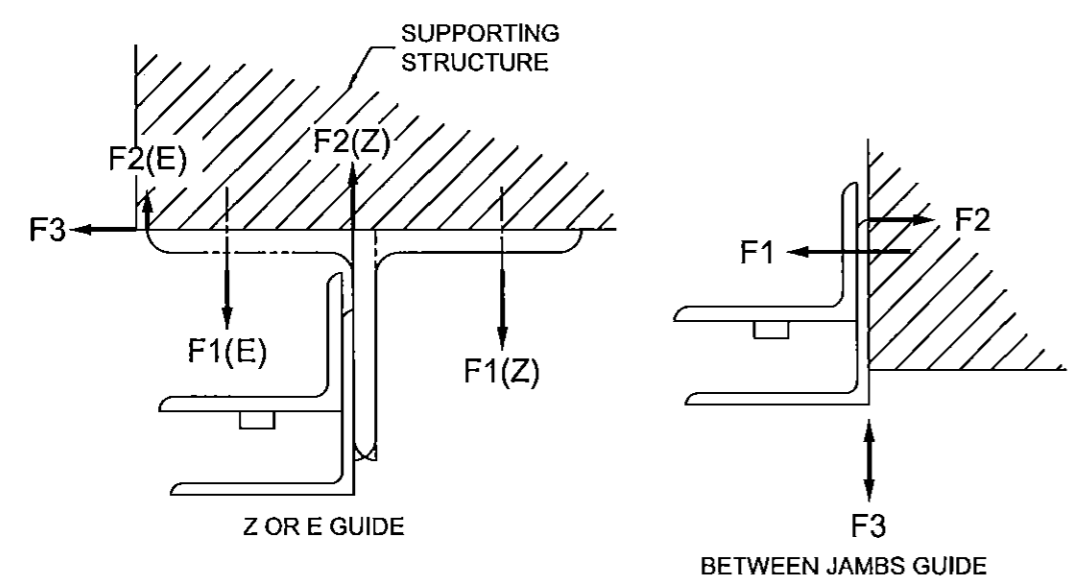

UNREDUCED WIND FORCES ON BUILDING STRUCTURE (LBS / FOOT OF HEIGHT)					
Z-GUIDE					
POSITIVE			NEGATIVE		
F1	F2	F3	F1	F2	F3
2294	1412	2636	4176	5058	2636
E-GUIDE					
POSITIVE			NEGATIVE		
F1	F2	F3	F1	F2	F3
6528	5646	2636	5488	6370	2636
BETWEEN JAMBS GUIDE					
POSITIVE			NEGATIVE		
F1	F2	F3	F1	F2	F3
4135	1500	882	13038	10402	882

BUILDING DESIGNER NOTE:
STRUCTURE MUST BE DESIGNED TO SUPPORT F1, F2, AND F3 FORCES (LBS./FT. OF OPENING HEIGHT) AT EACH JAMB.

Approved as complying with the Florida Building Code
 Date: 07/09/2015
 NOAH 15-0378.05
 Miami Dade Product Control
 By: *[Signature]*

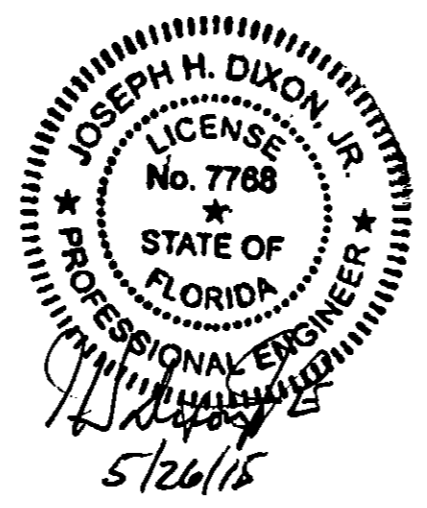

 COOKSON THE COOKSON COMPANY, INC.	24 ELMWOOD AVE 1901 S. LITCHFIELD RD MOUNTAINTOP, PA GOODYEAR, AZ 800 TULIP DRIVE GASTONIA, NC P: 800.390.8590 F: 866.448.6798 E: ADS@COOKSONDOOR.COM	Unless otherwise specified, dimensions are in inches & tolerances are: 0.000 = +/- 0.031 FRACTIONAL = +/- 1/32 ANGLES = +/- 1/2 DEG			
		TITLE: MIAMI DADE COUNTY APPROVED 14'-5" WIDE 120 PSF 80 FPS INSULATED ROLLING STEEL DOOR	DRAWN BY: TJE	SIZE: B	SCALE: AS NOTED
DWG NO: ES-16-57-TCCI					