

L'TR	REVISION	DATE	BY	E.C.O.
*	ORIGINAL ISSUE	10/15/14	TJE	1615

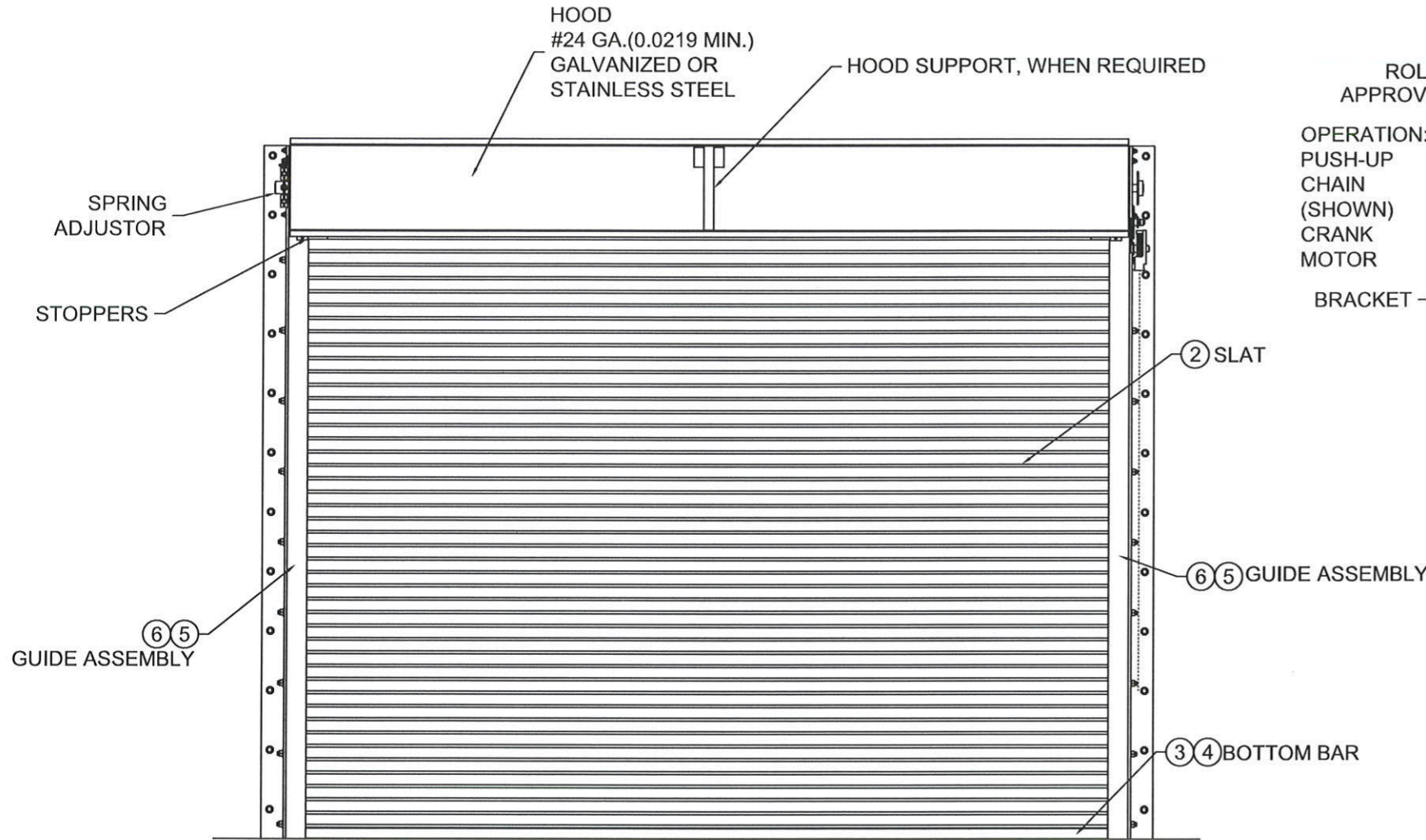

ROLL-UP MECHANISM NOT INCLUDED IN THIS APPROVAL. MUST BE CERTIFIED BY AN INDEPENDENT TESTING AGENCY IF REQUIRED.

OPERATION:
PUSH-UP
CHAIN
(SHOWN)
CRANK
MOTOR
BRACKET

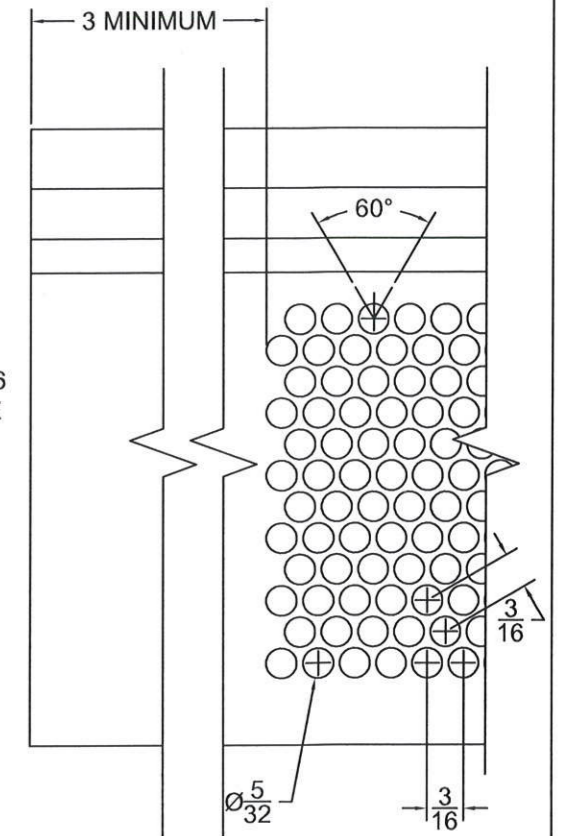
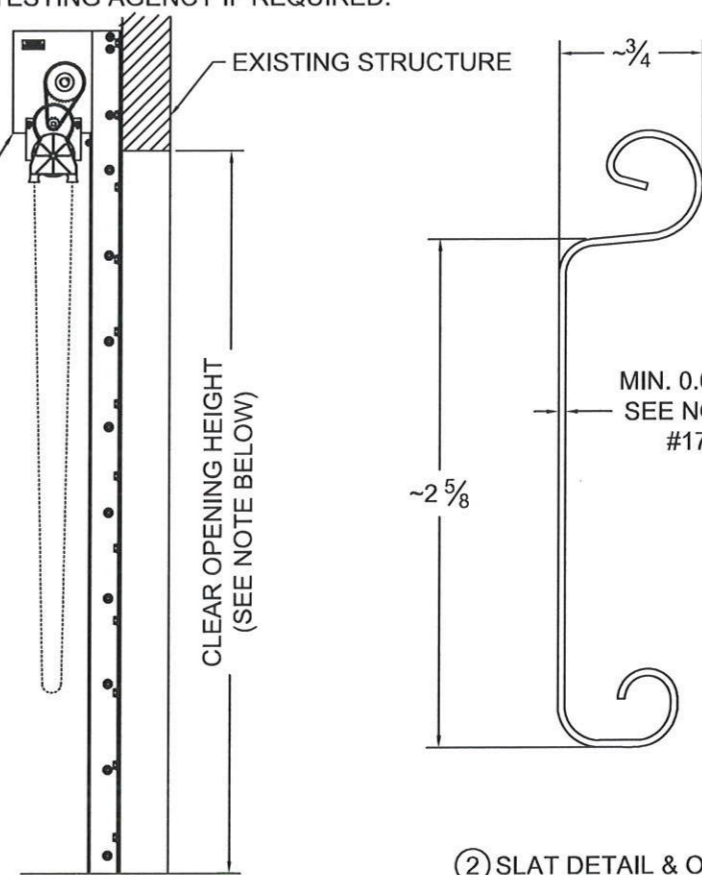

② SLAT DETAIL & OPTIONAL PERFORATION PATTERN
TYPICAL SECTION
ASTM A653 HSLAS TYPE B GRADE 40 G40 OR
ASTM A653 HSLAS TYPE A GRADE 40 G40 OR
ASTM A653 STRUCTURAL STEEL GRADE 40 G40
OR TYPE 304 STAINLESS STEEL (MIN. YIELD 40,000 psi)
OR TYPE 316 STAINLESS STEEL (MIN. YIELD 40,000 psi)
OR TYPE 430 STAINLESS STEEL (MIN. YIELD 40,000 psi)
OR TYPE 201 STAINLESS STEEL (MIN. YIELD 40,000 psi)
FULL SCALE

NOTE: WIND LOADS SPECIFIED IN TABLES ARE ACCEPTABLE FOR ANY C.O.H.. FOR GREATER THAN 30 FT, C.O.H., MOUNTING CONDITIONS SHALL BE DETERMINED ON A SITE SPECIFIC BASIS.

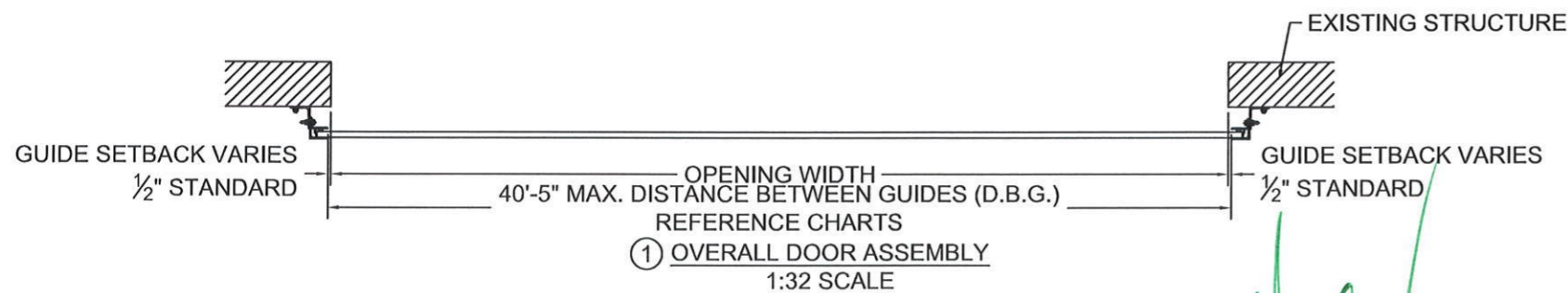

 COOKSON <small>THE COOKSON COMPANY, INC.</small>	24 ELMWOOD AVE 1901 S. LITCHFIELD RD MOUNTAINTOP, PA GOODYEAR, AZ 800 TULIP DRIVE GASTONIA, NC P: 800.390.8590 F: 866.448.6798 E: ADS@COOKSONDOOR.COM	Unless otherwise specified, dimensions are in inches & tolerances are: 0.000 = +/- 0.031 FRACTIONAL = +/- 1/32 ANGLES = +/- 1/2 DEG			
		TITLE: WIND LOAD CONFIGURATION NON-INSULATED ROLLING STEEL DOOR CP0020 SLAT IMPACT RATED	DRAWN BY: TJE	SIZE: B	SCALE: AS NOTED
DWG NO: ES-16-60-TCCI					

L'TR	REVISION	DATE	BY	E.C.O.
*	ORIGINAL ISSUE	10/15/14	TJE	1615

GENERAL NOTES:

1. THESE PRODUCT EVALUATION DOCUMENTS REPRESENT A ROLL-UP DOOR ASSEMBLY DESIGNED AND TESTED IN ACCORDANCE WITH THE STANDARD BUILDING CODE, THE INTERNATIONAL BUILDING CODE, AND THE FLORIDA BUILDING CODE.
2. THIS ROLL-UP DOOR HAS BEEN TESTED FOR UNIFORM STATIC PRESSURE, IMPACT AND FATIGUE RESISTANCE IN ACCORDANCE WITH THE FBC TEST PROTOCOLS FOR HIGH VELOCITY HURRICANE ZONES TAS 201, TAS 202, AND TAS 203.
3. A 33% INCREASE IN ALLOWABLE STRESS HAS NOT BEEN USED IN THE DESIGN OF THIS PRODUCT.
4. DETERMINE THE POSITIVE AND NEGATIVE DESIGN LOADS TO USE WHEN REFERENCING THESE DOCUMENTS IN ACCORDANCE WITH THE GOVERNING CODE AND GOVERNING WIND VELOCITY.
5. THESE PRODUCT EVALUATION DOCUMENTS ARE PREPARED BY THE PRODUCT ENGINEER AND ARE GENERIC. THEY DO NOT INCLUDE INFORMATION PREPARED FOR A SPECIFIC SITE.
6. THESE PRODUCT EVALUATION DOCUMENTS ARE NOT VALID FOR PERMIT WITHOUT ORIGINAL SIGNATURE, DATE AND EMBOSSED SEAL ON EACH PERMIT COPY, WHETHER OR NOT A MASTER APPROVAL DOCUMENT IS ON FILE WITH A MUNICIPALITY OR OTHER GOVERNING AGENCY.
7. THESE PRODUCT EVALUATION DOCUMENTS ARE SUITABLE TO BE APPLIED BY THE CONTRACTOR PROVIDED THE CONTRACTOR DOES NOT DEVIATE FROM THE CONDITIONS DETAILED HEREIN AND THE CONTRACTOR VERIFIES THE EXISTING STRUCTURE IS CAPABLE OF SUPPORTING THE SUPERIMPOSED LOADS Vx & Vy ON THE JAMBS OF THE DOOR.
8. ALTERATIONS OR ADDITIONS TO THIS DOCUMENT ARE NOT PERMITTED.
9. WHEN THE SITE CONDITIONS DEVIATE FROM THESE PRODUCT EVALUATION DOCUMENTS, SITE SPECIFIC DOCUMENTS SHALL BE PREPARED BY A DULY LICENSED AND REGISTERED ENGINEER OR ARCHITECT.
10. IF THE DEVIATING SITE SPECIFIC DOCUMENTS ARE PREPARED BY A DELEGATED REGISTERED ENGINEER OR ARCHITECT, SAID DOCUMENTS SHALL BEAR THE DATE, SIGNATURE, AND EMBOSSED SEAL OF THE DELEGATED ENGINEER OR ARCHITECT AND SHALL BE SUBMITTED TO THE PROJECT ENGINEER FOR REVIEW.
11. ALL HARDWARE SHALL BE GALVANIZED STEEL, PLATED STEEL OR STAINLESS STEEL.
12. ALL WINDLOCK RIVETS SHALL BE 1/4" STEEL RIVETS IFI GRADE 30 WITH A MINIMUM TENSILE STRENGTH OF 1,850 Lbs., AND SHEAR STRENGTH OF 2,400 Lbs., U.O.N.. RIVETS TO BE INSTALLED IN ALL WINDLOCK HOLES.
13. ENDLOCKS/WINDLOCKS SHALL BE CAST MALLEABLE IRON TYPE 32510 PER ASTM A47 OR CAST DUCTILE IRON PER ASTM A536 GRADE 65-45-12.
14. ALL WELDING SHALL BE PERFORMED BY QUALIFIED WELDERS IN ACCORDANCE WITH A.W.S. SPECIFICATIONS, LATEST EDITION. ALL WELDING ELECTRODES SHALL CONFORM TO A.W.S. A5.1 GRADE E-70. MINIMUM WELDING PROCESSES SHALL BE ARC WELDING A.W.S. E7014 OR MIG WELDING A.W.S. ER70S-6.
15. ANCHOR NOTES:
 - A. EMBEDMENT LENGTH DOES NOT INCLUDE STUCCO FINISH.
 - B. ANCHORS SHALL BE INSTALLED IN ACCORDANCE WITH MANUFACTURERS SPECIFICATIONS.
 - C. ANCHOR CAPACITY FOR THIS ROLL-UP DOOR IS BASED ON MIN. 3,000 P.S.I. CONCRETE EXCEPT WHERE NOTED..
 - D. FOR MINIMUM EMBEDMENT AND MINIMUM EDGE DISTANCE, REFER TO TABLES.
16. DOOR MAY BE INSTALLED ON THE INSIDE OR OUTSIDE OF AN EXTERIOR WALL.
17. IF OPTIONAL PERFORATION PATTERN IS CHOSEN, MINIMUM SLAT THICKNESS IS 0.0405"
18. ALL SHAPES USED FOR GUIDE ASSEMBLIES MUST CONFORM TO ATSM A36 FOR STEEL OR ASTM A276 FOR TYPES 304 OR 316 WITH A MINIMUM 36 KSI YIELD STRENGTH.

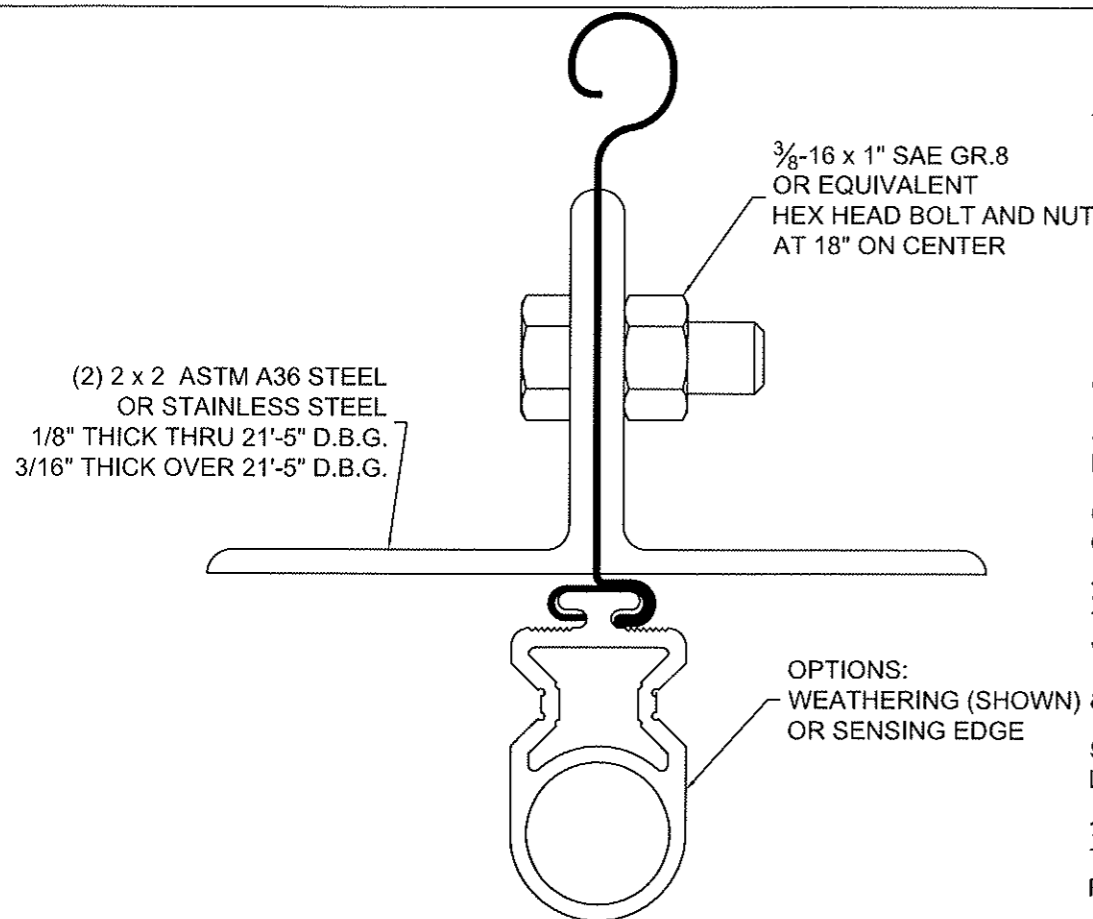

③ DOUBLE ANGLE BOTTOM BAR DETAIL
TYPICAL SECTION
FULL SCALE

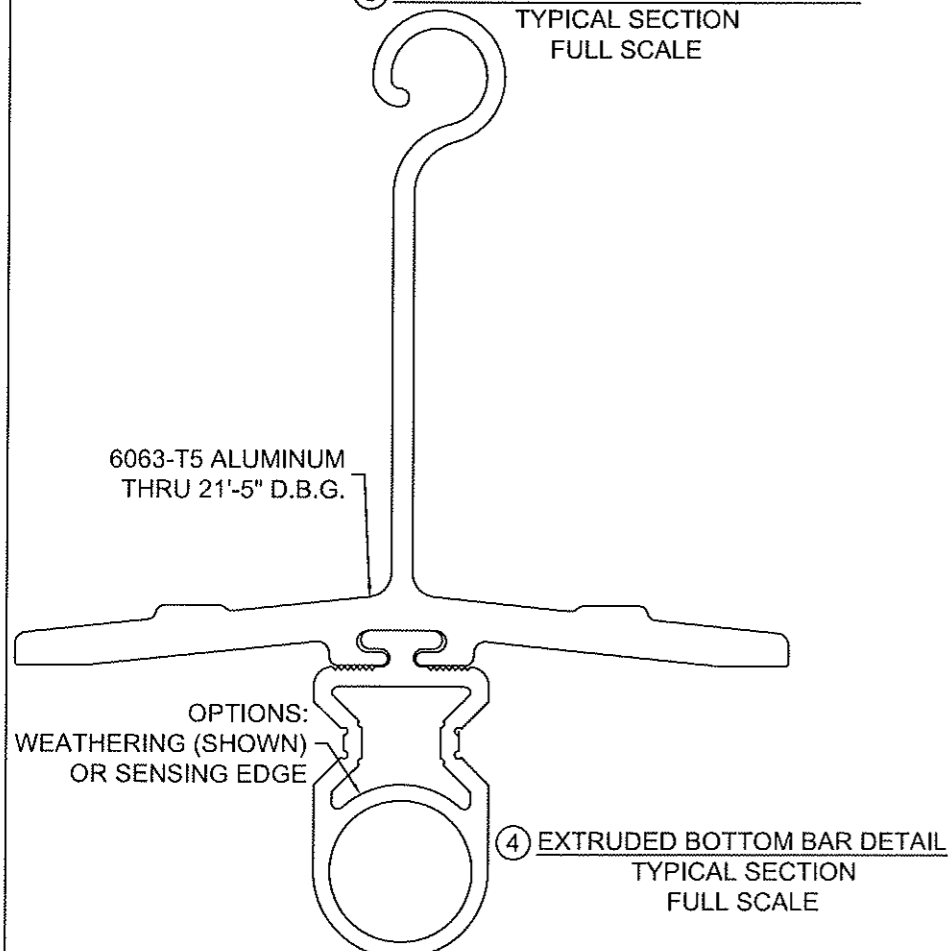

④ EXTRUDED BOTTOM BAR DETAIL
TYPICAL SECTION
FULL SCALE

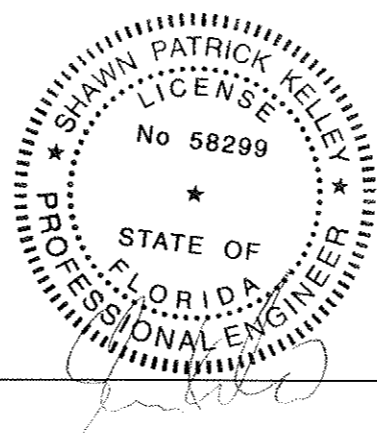

 COOKSON <small>THE COOKSON COMPANY, INC.</small>	24 ELMWOOD AVE 1901 S. LITCHFIELD RD MOUNTAINTOP, PA GOODYEAR, AZ 800 TULIP DRIVE GASTONIA, NC P: 800.390.8590 F: 866.448.6798 E: ADS@COOKSONDOOR.COM		Unless otherwise specified, dimensions are in inches & tolerances are: 0.000 = +/- 0.031 FRACTIONAL = +/- 1/32 ANGLES = +/- 1/2 DEG		
	TITLE: WIND LOAD CONFIGURATION NON-INSULATED ROLLING STEEL DOOR CP0020 SLAT IMPACT RATED		DRAWN BY: TJE	SIZE: B	SCALE: AS NOTED
DWG NO: ES-16-60-TCCI					

L'TR	REVISION	DATE	BY	E.C.O.
*	ORIGINAL ISSUE	10/15/14	TJE	1615

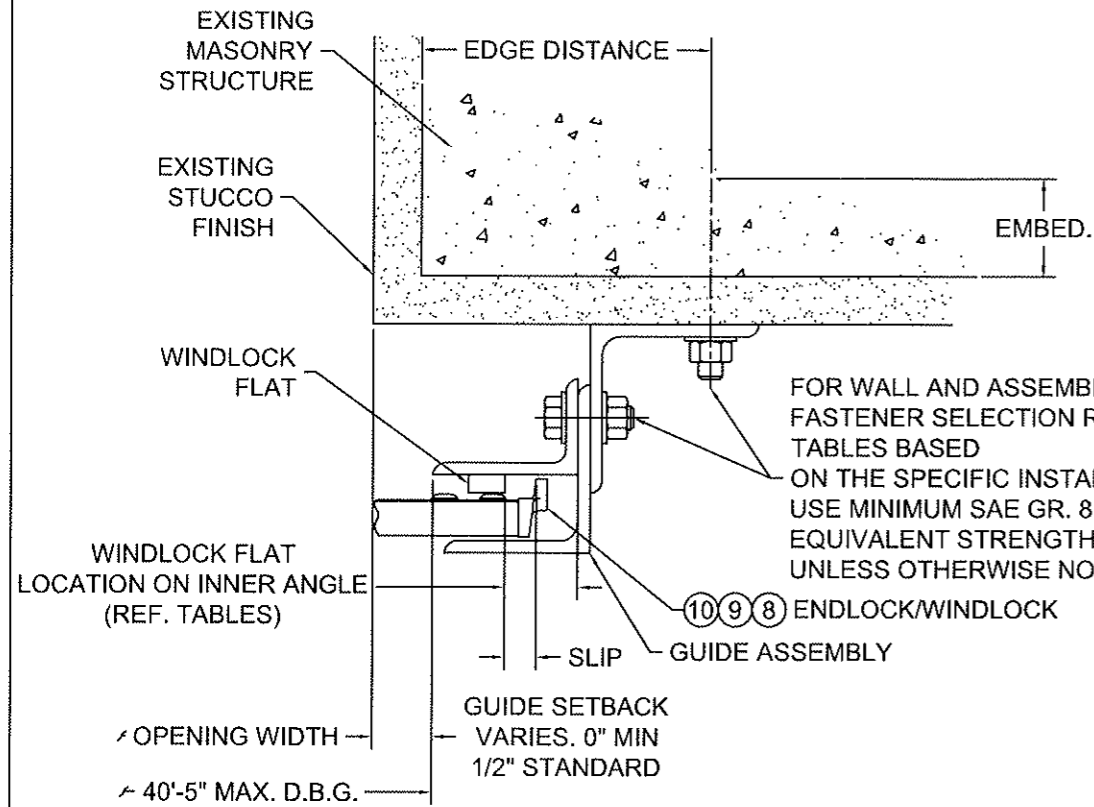

NOTE:
THROUGH BOLTING TO FILLED BLOCK REQUIRES THE USE OF 1/4"
THICK STEEL OR STAINLESS STEEL CRUSH PLATE

⑤ GUIDE ASSEMBLY
CONCRETE OR FILLED BLOCK
STRUCTURE
(Z-GUIDE)

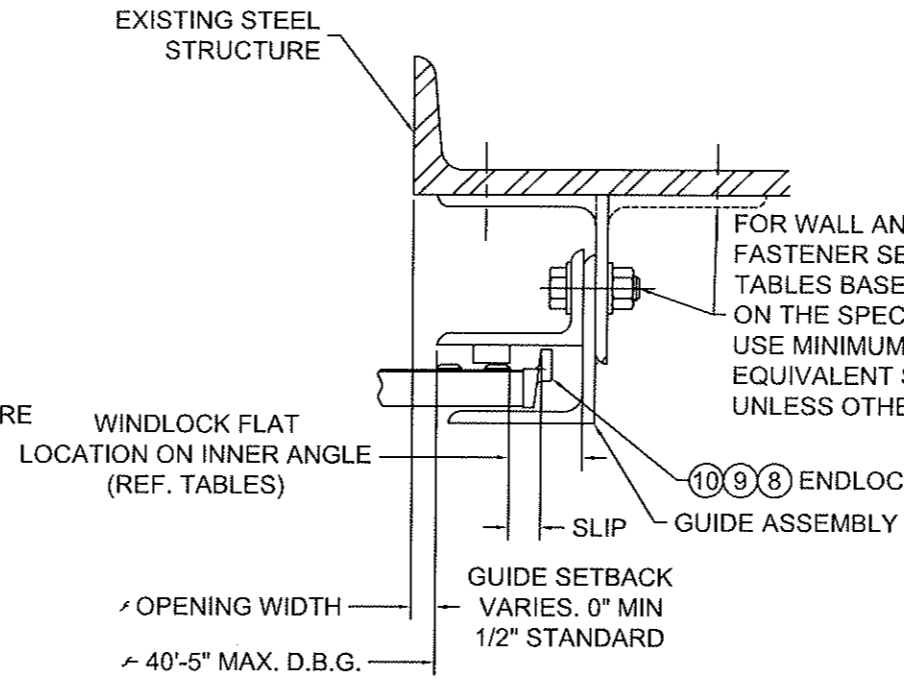

⑥ GUIDE ASSEMBLY
STEEL STRUCTURE
(Z-GUIDE OR E-GUIDE)

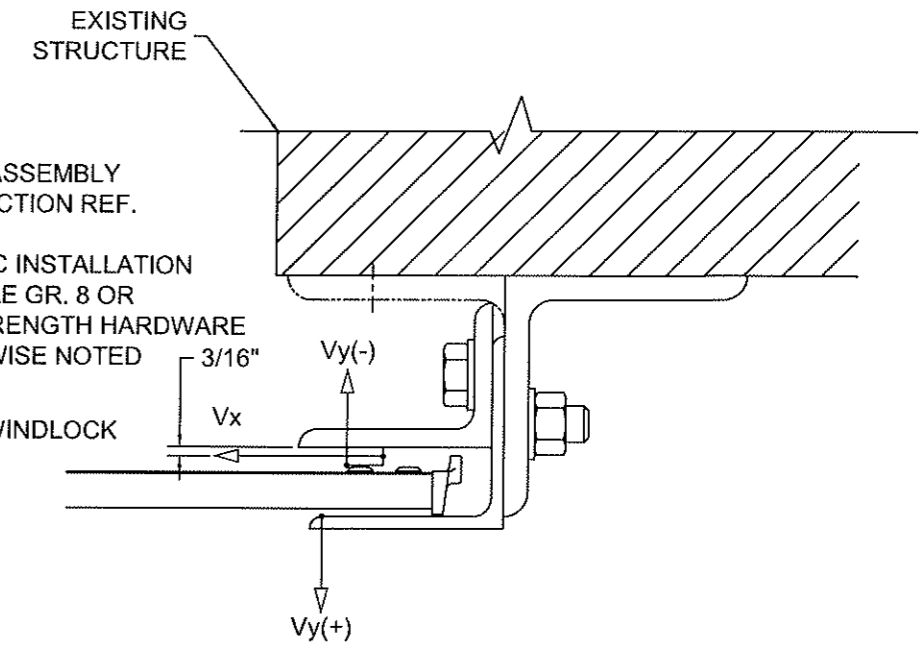

NOTE:

1. Vx & Vy ARE HORIZ. AND VERT. COMPONENTS OF THE REACTION, RESPECTIVELY, RESULTING FROM WIND LOADS ON THE ROLL-UP DOOR. THE EXISTING STRUCTURE SHALL BE CAPABLE OF RESISTING Vx & Vy FORCES SHOWN AND THE CORRESPONDING REACTIONS DUE TO THE ECCENTRICITIES OF THE FORCES.

⑦ SUPERIMPOSED LOAD DIAGRAM
SCALE: 3" = 1'-0"

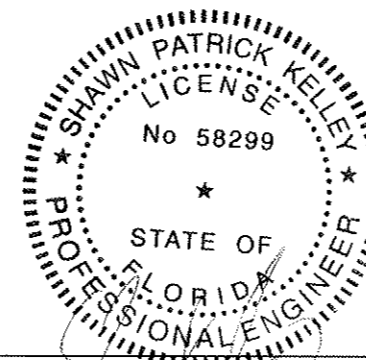

24 ELMWOOD AVE 1901 S. LITCHFIELD RD
MOUNTAINTOP, PA GOODYEAR, AZ
800 TULIP DRIVE
GASTONIA, NC
P: 800.390.8590
F: 866.448.6798
E: ADS@COOKSONDOOR.COM

Unless otherwise specified,
dimensions are in inches &
tolerances are:

0.000 = +/- 0.031
FRACTIONAL = +/- 1/32
ANGLES = +/- 1/2 DEG

TITLE: WIND LOAD CONFIGURATION
NON-INSULATED ROLLING STEEL DOOR
CP0020 SLAT IMPACT RATED

DRAWN BY: TJE
SIZE: B
SCALE: AS NOTED
SHEET: 3/19
DWG NO: ES-16-60-TCCI

L'TR	REVISION	DATE	BY	E.C.O.
*	ORIGINAL ISSUE	10/15/14	TJE	1615

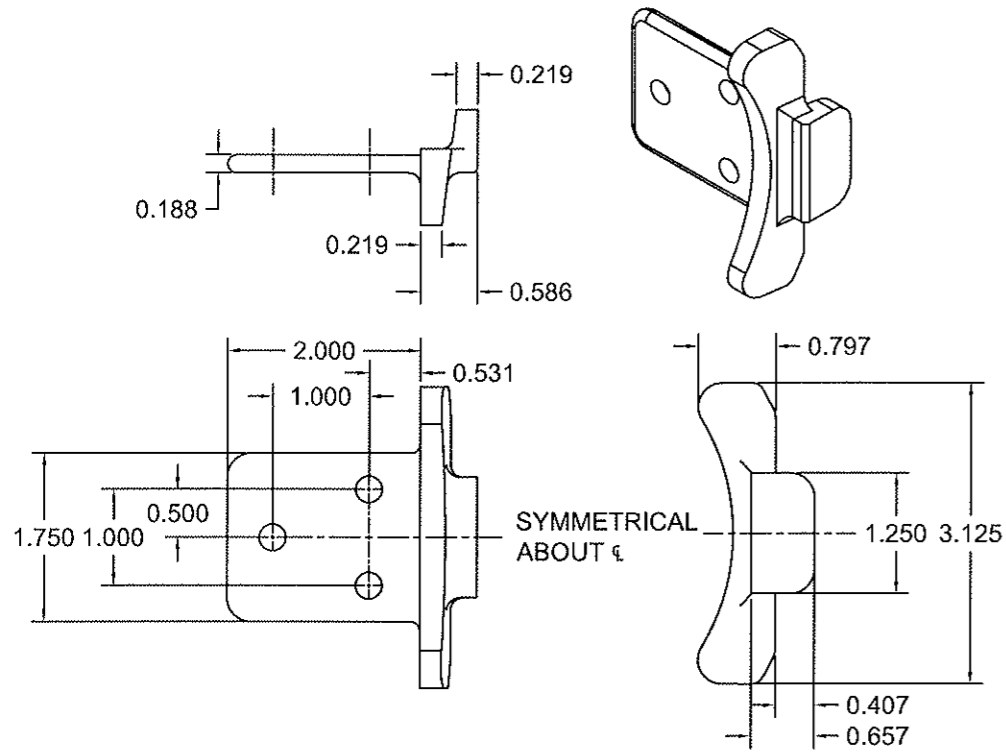

⑧ ENDLOCK / WINDLOCK DETAIL, CP1152
 CAST MALLEABLE IRON ASTM A47, GRADE 32510, OR
 DUCTILE IRON PER ASTM A536 GRADE 65-45-12, GALVANIZED IN ACCORDANCE WITH
 ASTM A123, GRADE 85 ZINC-COATING
 1/2 SCALE

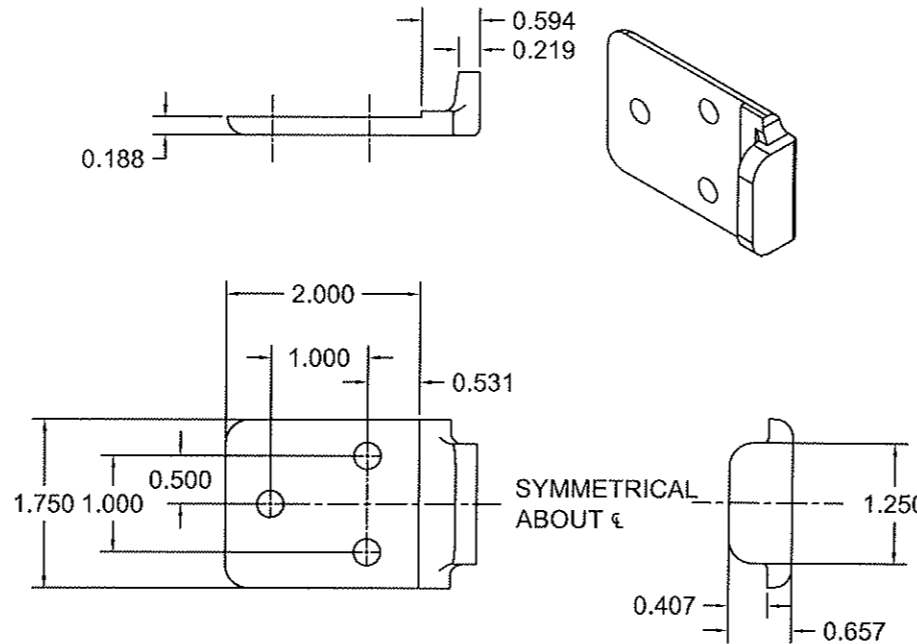

⑨ WINDLOCK DETAIL, CP1153
 CAST MALLEABLE IRON ASTM A47, GRADE 32510, OR
 DUCTILE IRON PER ASTM A536 GRADE 65-45-12, GALVANIZED IN
 ACCORDANCE WITH ASTM A123, GRADE 85 ZINC-COATING
 1/2 SCALE

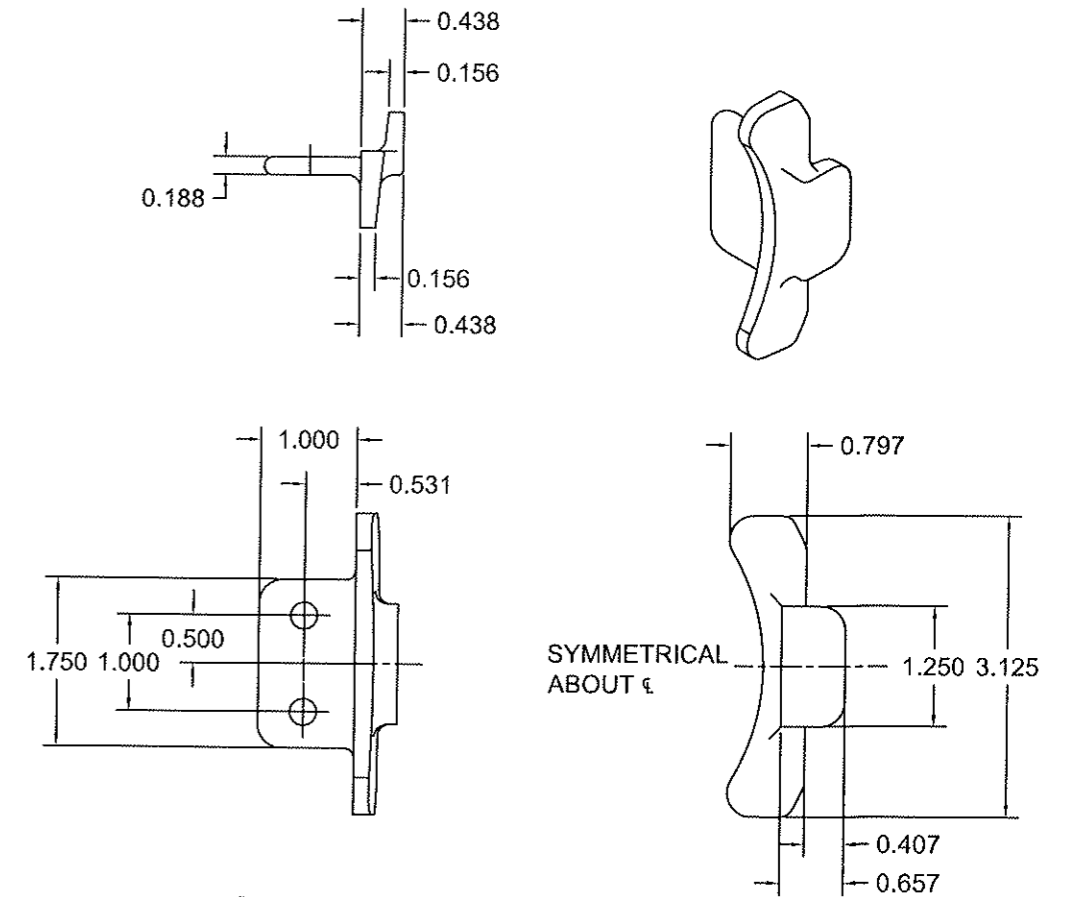

⑩ ENDLOCK / WINDLOCK DETAIL, CP1151
 CAST MALLEABLE IRON ASTM A47, GRADE 32510, OR
 DUCTILE IRON PER ASTM A536 GRADE 65-45-12, GALVANIZED IN ACCORDANCE WITH
 ASTM A123, GRADE 85 ZINC-COATING
 1/2 SCALE

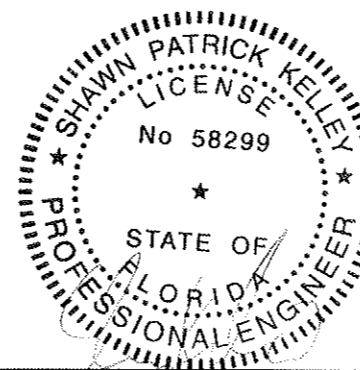

COOKSON
 THE COOKSON COMPANY, INC.

24 ELMWOOD AVE 1901 S. LITCHFIELD RD
 MOUNTAINTOP, PA GOODYEAR, AZ
 800 TULIP DRIVE
 GASTONIA, NC
 P: 800.390.8590
 F: 866.448.6798
 E: ADS@COOKSONDOOR.COM

Unless otherwise specified,
 dimensions are in inches &
 tolerances are:
 0.000 = +/- 0.031
 FRACTIONAL = +/- 1/32
 ANGLES = +/- 1/2 DEG

TITLE: WIND LOAD CONFIGURATION
 NON-INSULATED ROLLING STEEL DOOR
 CP0020 SLAT IMPACT RATED

DRAWN BY: TJE
 SIZE: B
 SCALE: AS NOTED
 SHEET: 4/19
 DWG NO: ES-16-60-TCCI

L'TR	REVISION	DATE	BY	E.C.O.
*	ORIGINAL ISSUE	10/15/14	TJE	1615

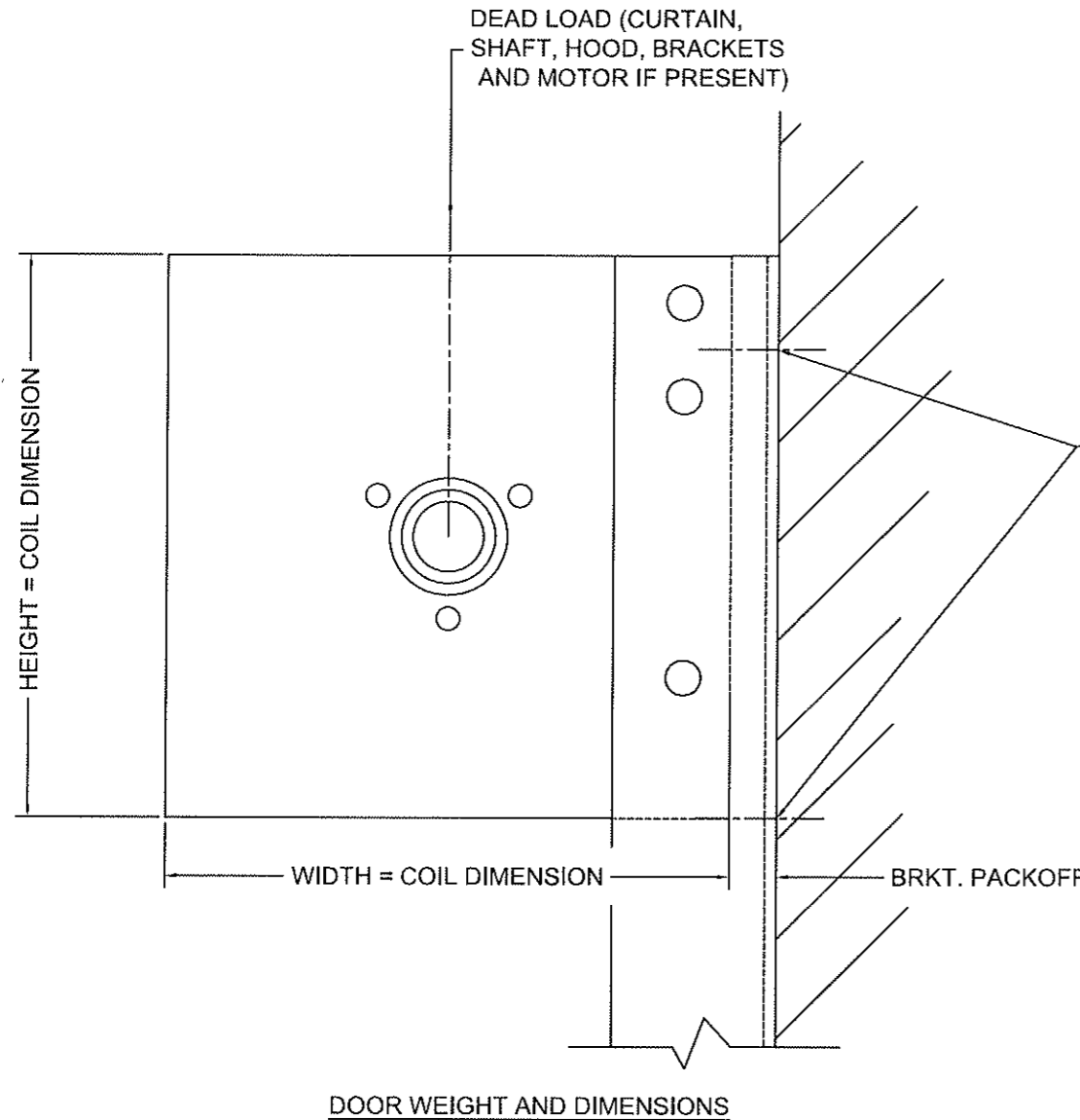

FOR "WALL ANGLE" TO WALL CONNECTION, REF. TABLES BASED ON THE SPECIFIC INSTALLATION. USE AT LEAST ONE FASTENER OR WELD AT THE INDICATED LOCATIONS.

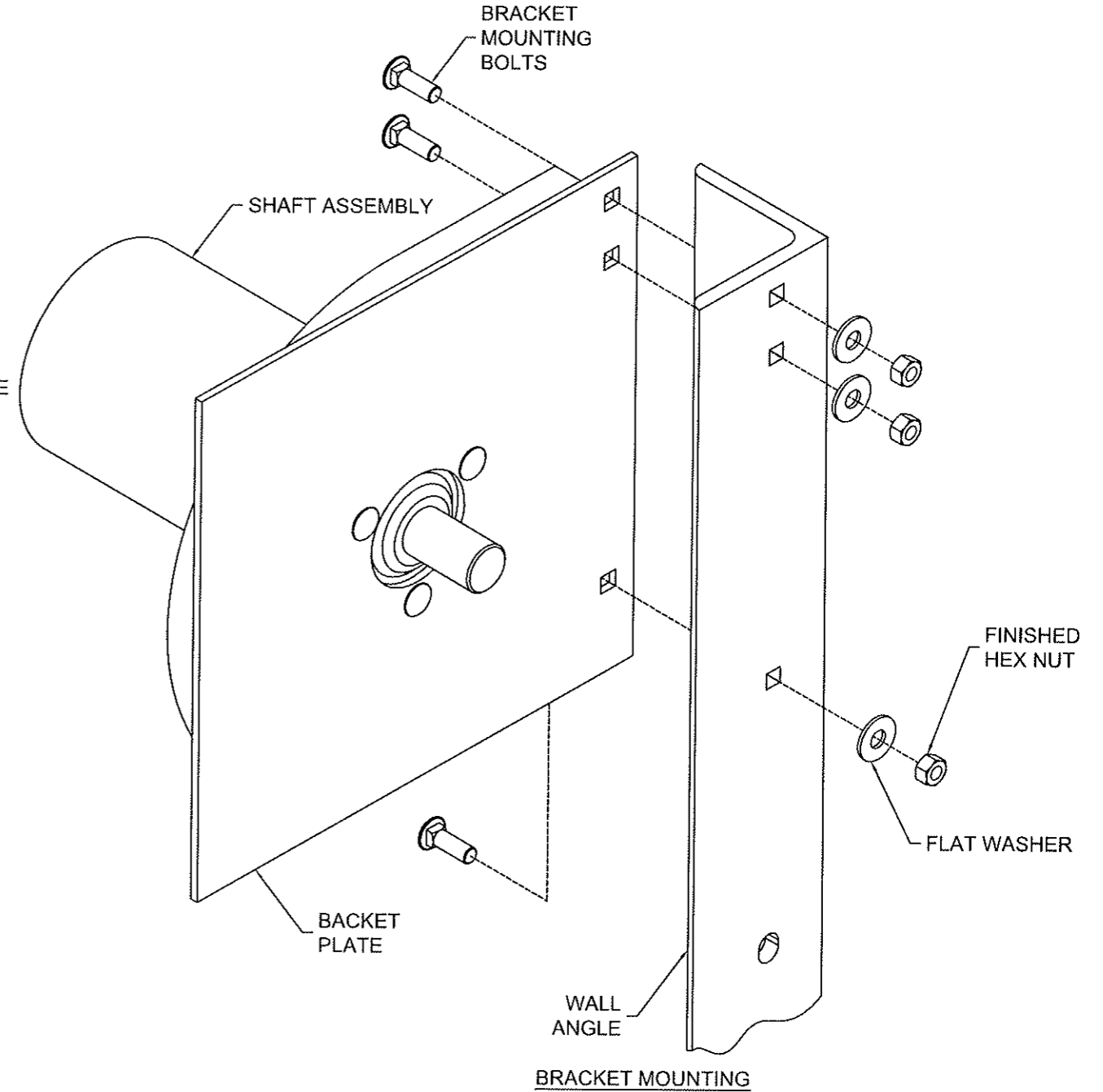

NOTE:

1. WHEN MOTOR IS PROVIDED, HEIGHT OR WIDTH DIMENSION MAY INCREASE UP TO 2-1/2" BASED ON MOTOR LOCATION. WHEN AN 8" DIAMETER OR LARGER SHAFT ASSEMBLY IS PROVIDED, HEIGHT DIMENSION INCREASES BY 2".

NOTE:

1. STANDARD BRACKET MOUNTING DETAIL IS DEPICTED, OTHER MOUNTINGS ARE AVAILABLE

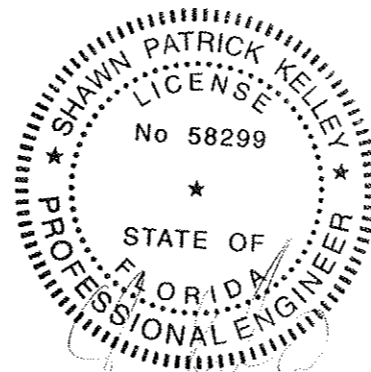

<p>COOKSON THE COOKSON COMPANY, INC.</p>	24 ELMWOOD AVE 1901 S. LITCHFIELD RD MOUNTAINTOP, PA GOODYEAR, AZ 800 TULIP DRIVE GASTONIA, NC P: 800.390.8590 F: 866.448.6798 E: ADS@COOKSONDOOR.COM	Unless otherwise specified, dimensions are in inches & tolerances are: 0.000 = +/- 0.031 FRACTIONAL = +/- 1/32 ANGLES = +/- 1/2 DEG
	TITLE: WIND LOAD CONFIGURATION NON-INSULATED ROLLING STEEL DOOR CP0020 SLAT IMPACT RATED	DRAWN BY: TJE DWG NO: ES-16-60-TCCI

L'TR	REVISION	DATE	BY	E.C.O.
*	ORIGINAL ISSUE	10/15/14	TJE	1615

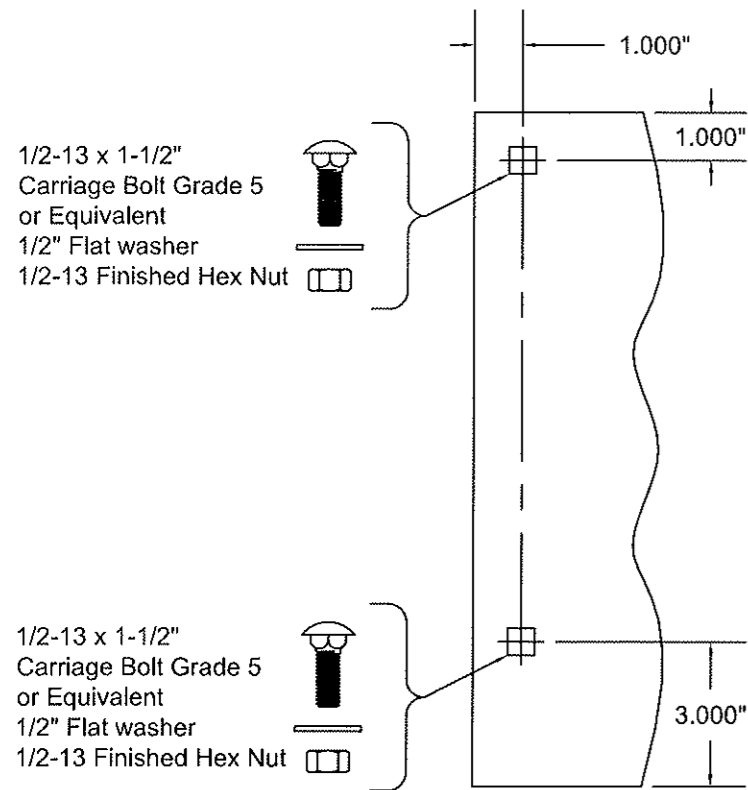

1/2-13 x 1-1/2"
Carriage Bolt Grade 5
or Equivalent
1/2" Flat washer
1/2-13 Finished Hex Nut

1/2-13 x 1-1/2"
Carriage Bolt Grade 5
or Equivalent
1/2" Flat washer
1/2-13 Finished Hex Nut

THRU 6"Ø SHAFT ASSEMBLY
14" THRU 16" COIL DIMENSION
MIN. THICKNESS 0.172" ASTM A36 STEEL
OR ASTM A480 STAINLESS STEEL,
TYPES 304 OR 316, MIN. 36 KSI YIELD STRENGTH
SCALE: 1-1/2" = 1'-0"

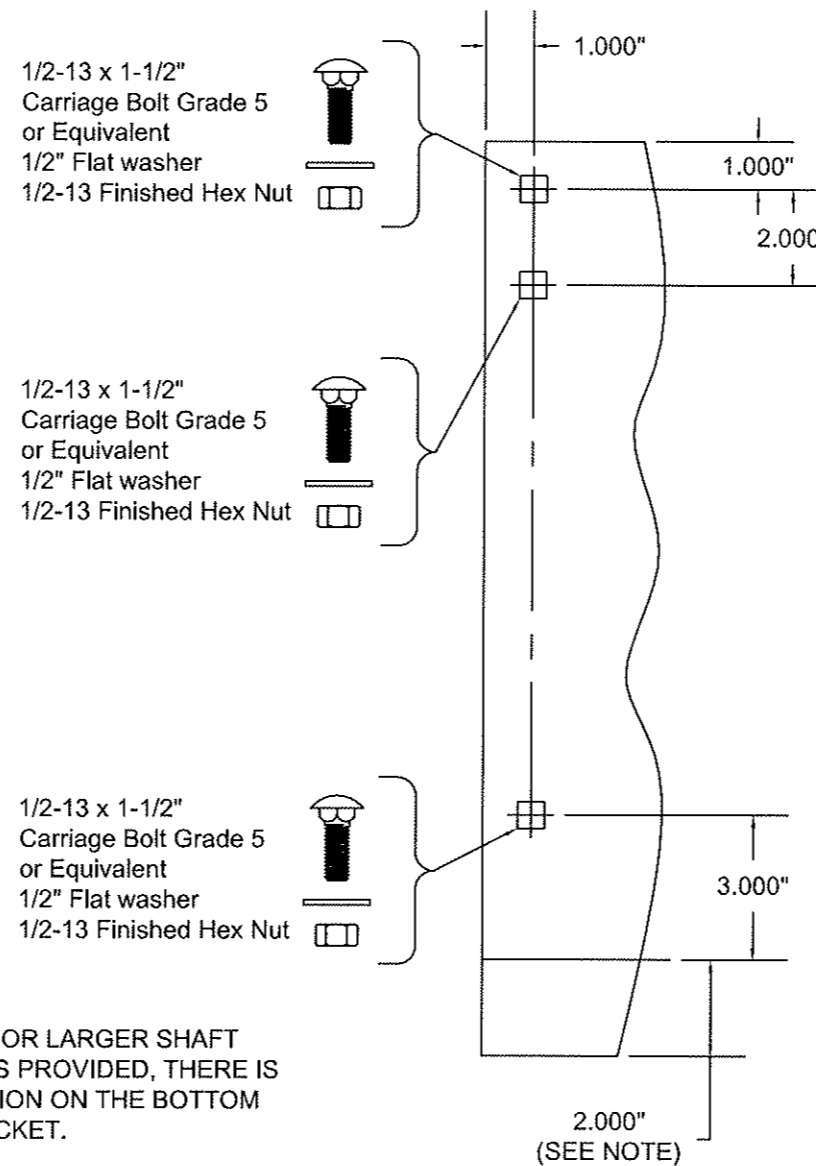

1/2-13 x 1-1/2"
Carriage Bolt Grade 5
or Equivalent
1/2" Flat washer
1/2-13 Finished Hex Nut

1/2-13 x 1-1/2"
Carriage Bolt Grade 5
or Equivalent
1/2" Flat washer
1/2-13 Finished Hex Nut

1/2-13 x 1-1/2"
Carriage Bolt Grade 5
or Equivalent
1/2" Flat washer
1/2-13 Finished Hex Nut

THRU 10"Ø SHAFT ASSEMBLY
17" AND LARGER COIL DIMENSION
MIN. THICKNESS 0.240" ASTM A36 STEEL
OR ASTM A480 STAINLESS STEEL,
TYPES 304 OR 316, MIN. 36 KSI YIELD STRENGTH
SCALE: 1-1/2" = 1'-0"

NOTE:
WHEN A 8"Ø OR LARGER SHAFT
ASSEMBLY IS PROVIDED, THERE IS
A 2" EXTENSION ON THE BOTTOM
OF THE BRACKET.

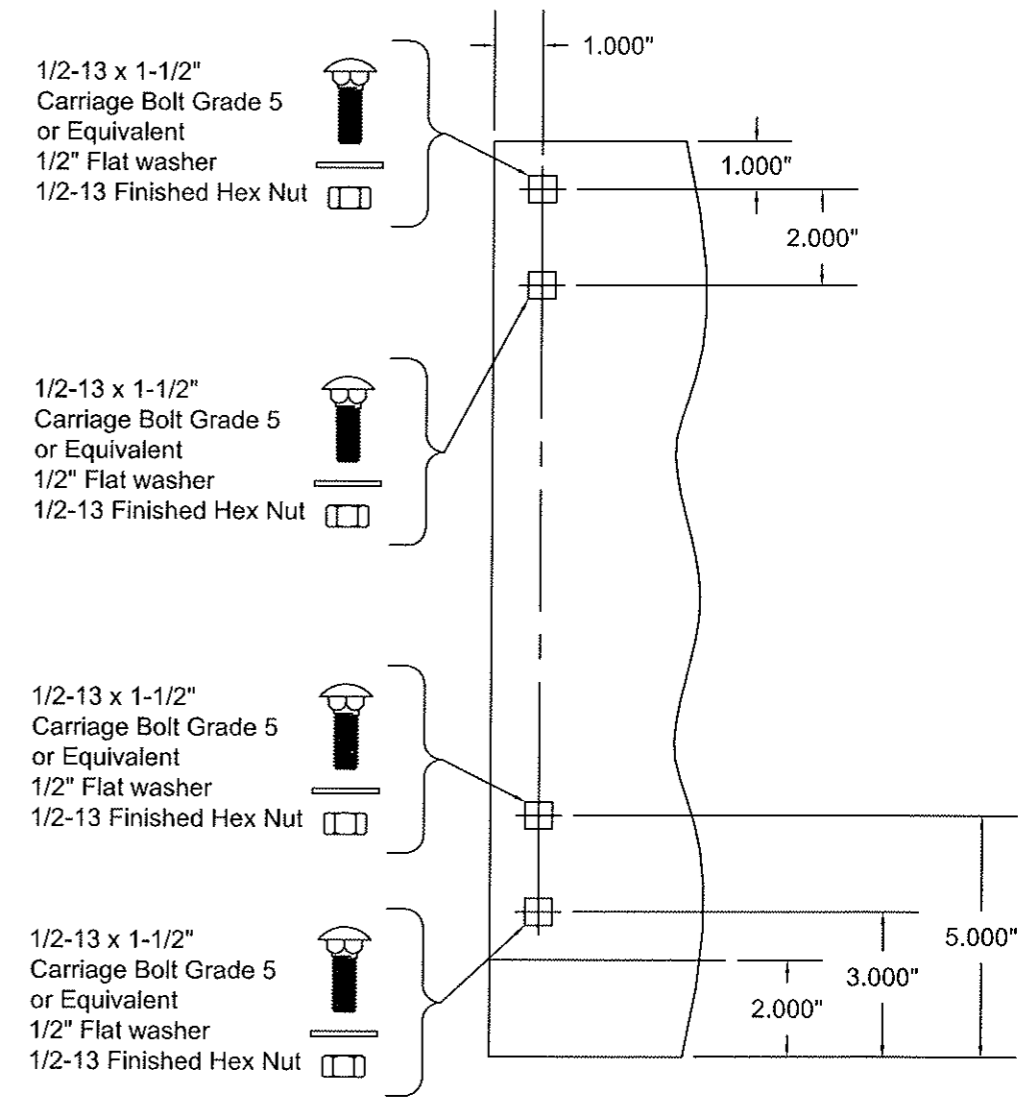

1/2-13 x 1-1/2"
Carriage Bolt Grade 5
or Equivalent
1/2" Flat washer
1/2-13 Finished Hex Nut

1/2-13 x 1-1/2"
Carriage Bolt Grade 5
or Equivalent
1/2" Flat washer
1/2-13 Finished Hex Nut

1/2-13 x 1-1/2"
Carriage Bolt Grade 5
or Equivalent
1/2" Flat washer
1/2-13 Finished Hex Nut

1/2-13 x 1-1/2"
Carriage Bolt Grade 5
or Equivalent
1/2" Flat washer
1/2-13 Finished Hex Nut

12"Ø SHAFT ASSEMBLY
17" AND LARGER COIL DIMENSION
MIN. THICKNESS 0.240" ASTM A36 STEEL
OR ASTM A480 STAINLESS STEEL,
TYPES 304 OR 316, MIN. 36 KSI YIELD STRENGTH
SCALE: 1-1/2" = 1'-0"

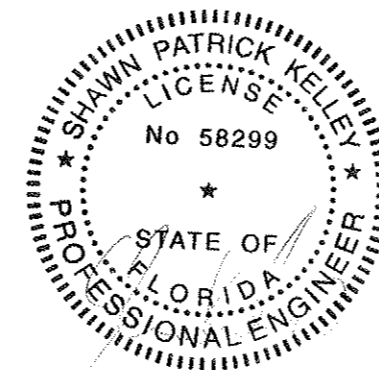

 COOKSON THE COOKSON COMPANY, INC.	24 ELMWOOD AVE 1901 S. LITCHFIELD RD MOUNTAINTOP, PA GOODYEAR, AZ 800 TULIP DRIVE GASTONIA, NC P: 800.390.8590 F: 866.448.6798 E: ADS@COOKSONDOOR.COM	Unless otherwise specified, dimensions are in inches & tolerances are: 0.000 = +/- 0.031 FRACTIONAL = +/- 1/32 ANGLES = +/- 1/2 DEG		
		TITLE: WIND LOAD CONFIGURATION NON-INSULATED ROLLING STEEL DOOR CP0020 SLAT IMPACT RATED	DRAWN BY: TJE	SIZE: B
DWG NO: ES-16-60-TCCI				

L'TR	REVISION	DATE	BY	E.C.O.
*	ORIGINAL ISSUE	10/15/14	TJE	1615

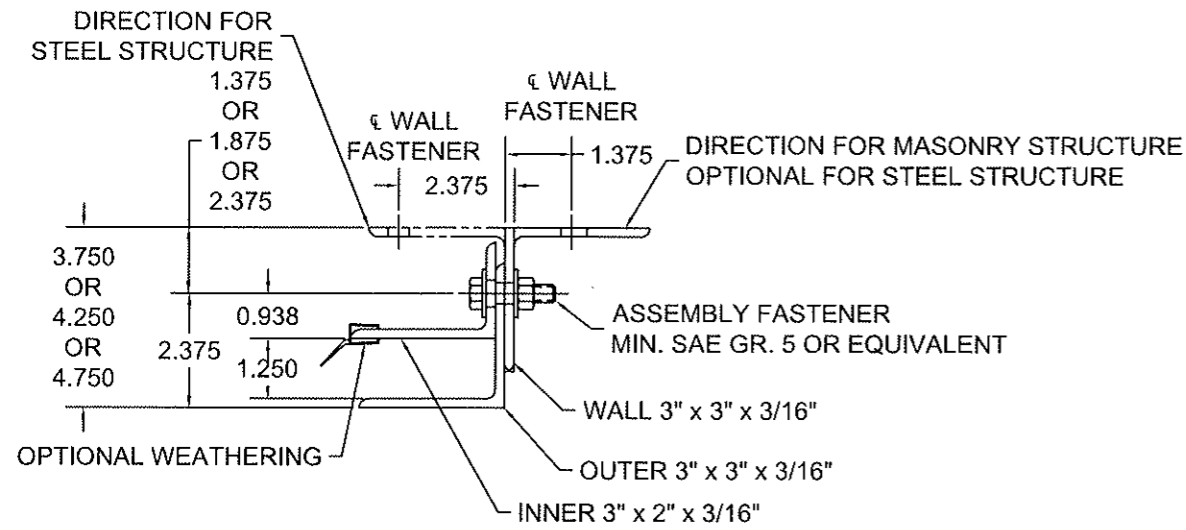

GUIDE ASSEMBLY TYPE 333* (NON-WINDLOCK)
SCALE: 3" = 1'-0"

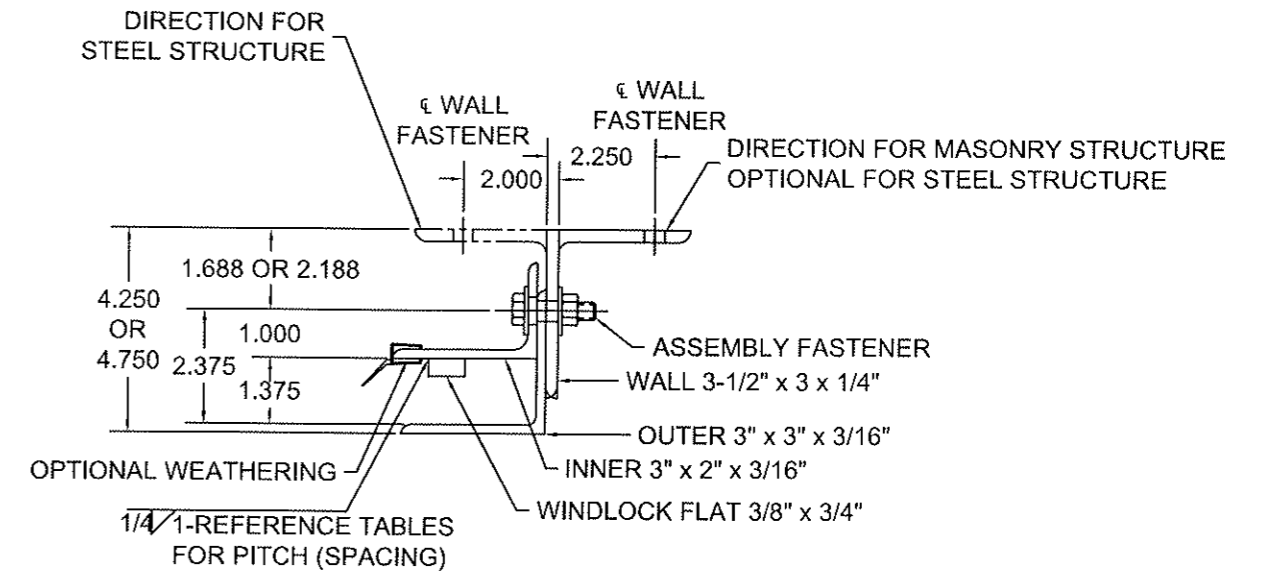

GUIDE ASSEMBLY TYPE 334
SCALE: 3" = 1'-0"

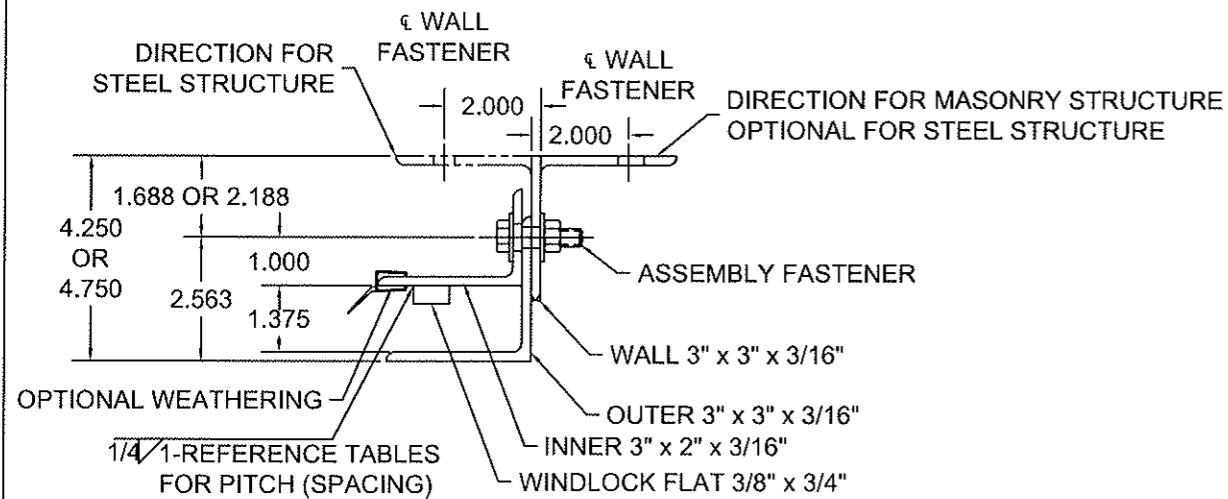

GUIDE ASSEMBLY TYPE 333
SCALE: 3" = 1'-0"

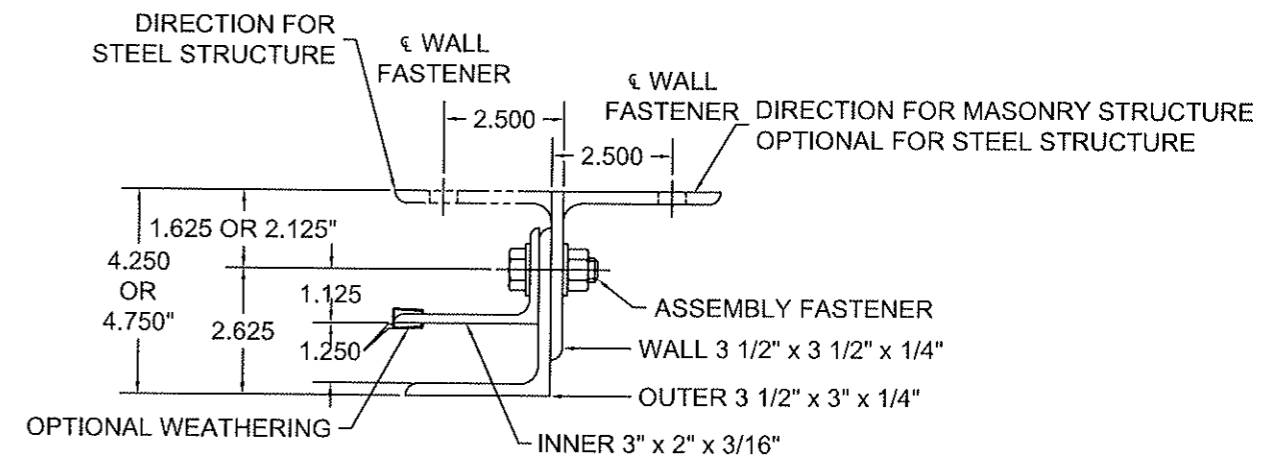

GUIDE ASSEMBLY TYPE 344* (NON-WINDLOCK)
SCALE: 3" = 1'-0"

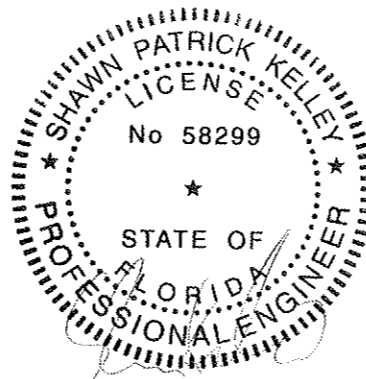

COOKSON
THE COOKSON COMPANY, INC.

24 ELMWOOD AVE 1901 S. LITCHFIELD RD
MOUNTAINTOP, PA GOODYEAR, AZ
800 TULIP DRIVE
GASTONIA, NC
P: 800.390.8590
F: 866.448.6798
E: ADS@COOKSONDOOR.COM

Unless otherwise specified,
dimensions are in inches &
tolerances are:

0.000 = +/- 0.031
FRACTIONAL = +/- 1/32
ANGLES = +/- 1/2 DEG

TITLE: WIND LOAD CONFIGURATION
NON-INSULATED ROLLING STEEL DOOR
CP0020 SLAT IMPACT RATED

DRAWN BY: TJE
SIZE: B
SCALE: AS NOTED
SHEET: 7/19
DWG NO: ES-16-60-TCCI

L'TR	REVISION	DATE	BY	E.C.O.
*	ORIGINAL ISSUE	10/15/14	TJE	1615

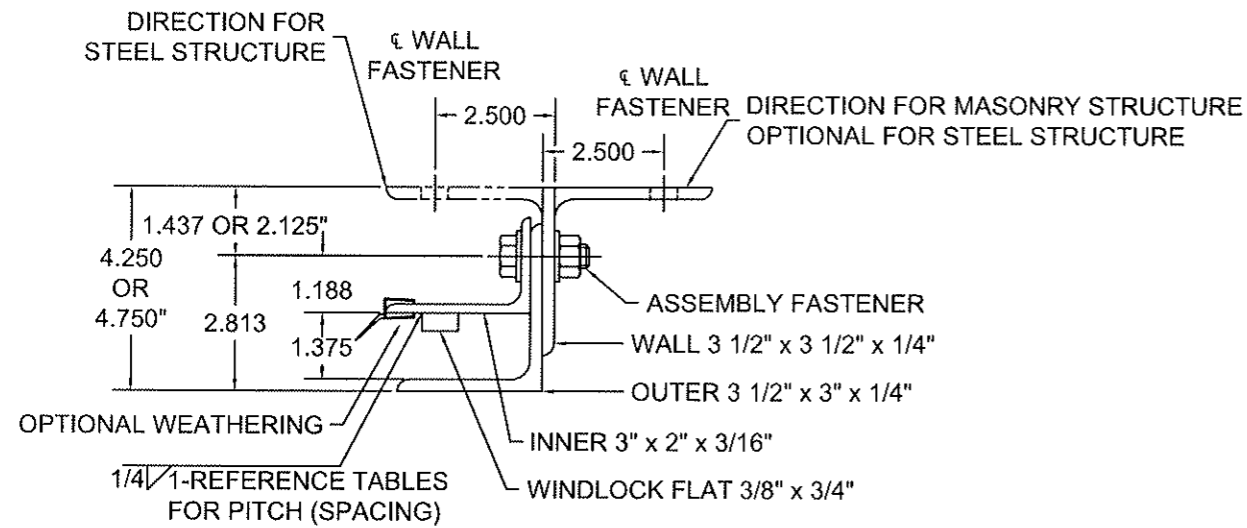

GUIDE ASSEMBLY TYPE 344
SCALE: 3" = 1'-0"

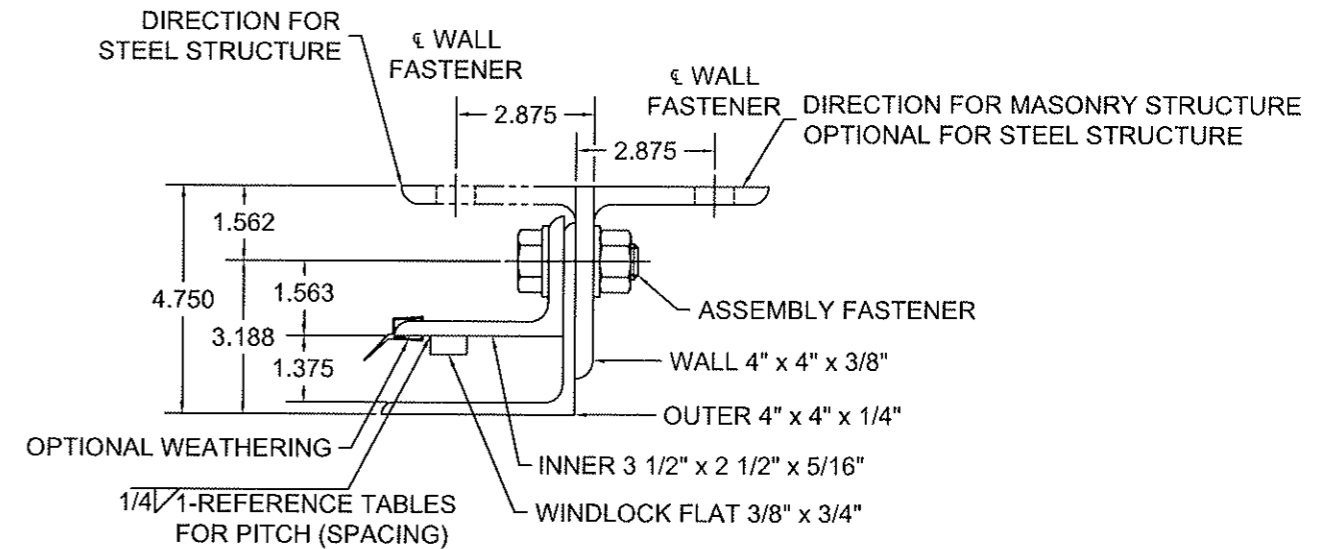

GUIDE ASSEMBLY TYPE 546
SCALE: 3" = 1'-0"

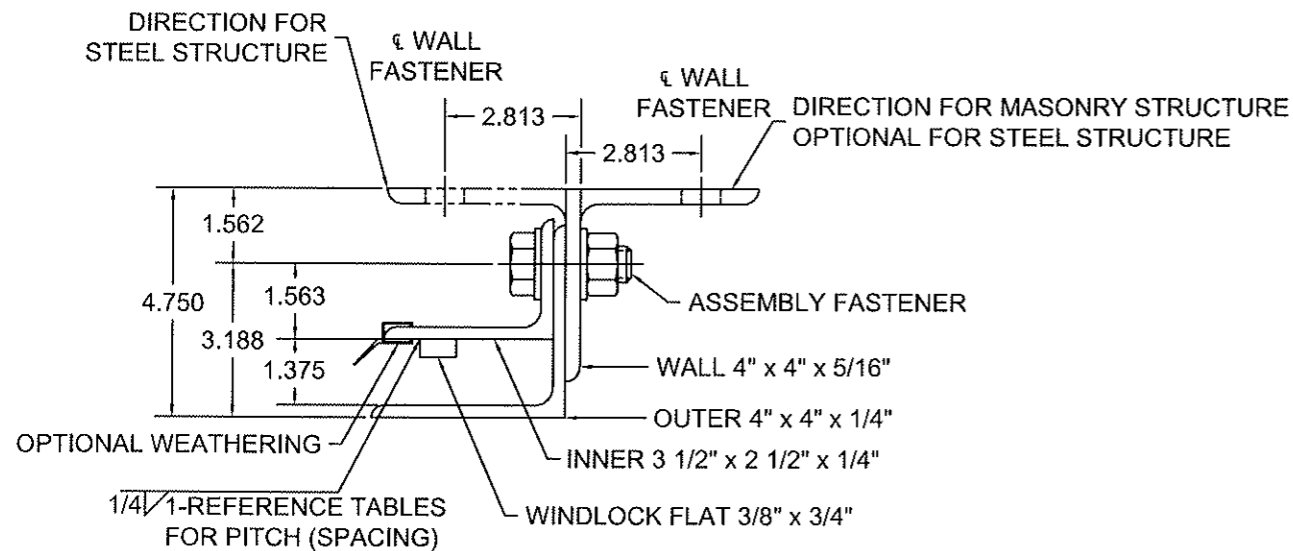

GUIDE ASSEMBLY TYPE 445
SCALE: 3" = 1'-0"

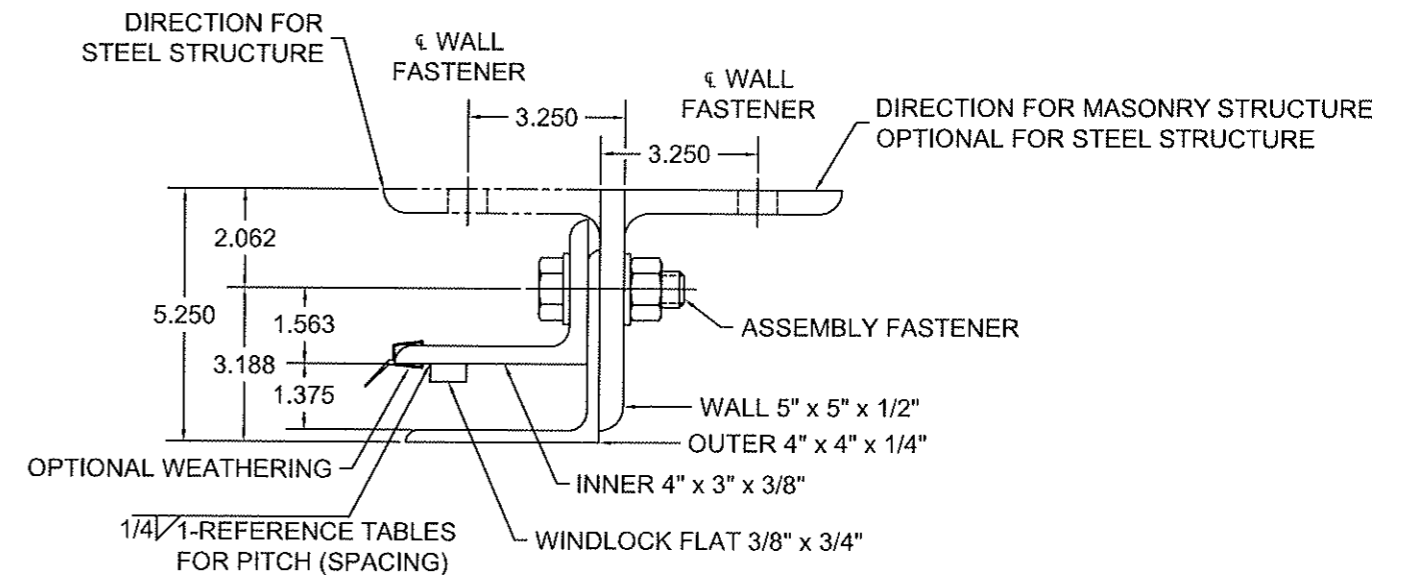

GUIDE ASSEMBLY TYPE 648
SCALE: 3" = 1'-0"

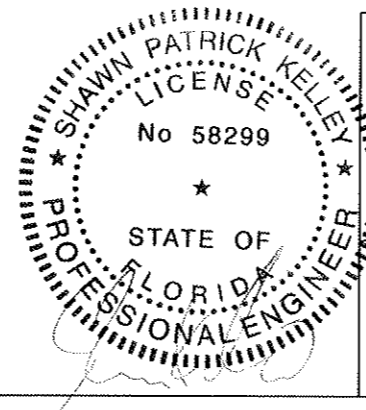

COOKSON
THE COOKSON COMPANY, INC.

24 ELMWOOD AVE 1901 S. LITCHFIELD RD
MOUNTAINTOP, PA GOODYEAR, AZ
800 TULIP DRIVE
GASTONIA, NC
P: 800.390.8590
F: 866.448.6798
E: ADS@COOKSONDOOR.COM

Unless otherwise specified,
dimensions are in inches &
tolerances are:
0.000 = +/- 0.031
FRACTIONAL = +/- 1/32
ANGLES = +/- 1/2 DEG

TITLE: WIND LOAD CONFIGURATION
NON-INSULATED ROLLING STEEL DOOR
CP0020 SLAT IMPACT RATED

DRAWN BY: TJE
SIZE: B
SCALE: AS NOTED
SHEET: 8/19
DWG NO: ES-16-60-TCCI

L'TR	REVISION	DATE	BY	E.C.O.
*	ORIGINAL ISSUE	10/15/14	TJE	1615

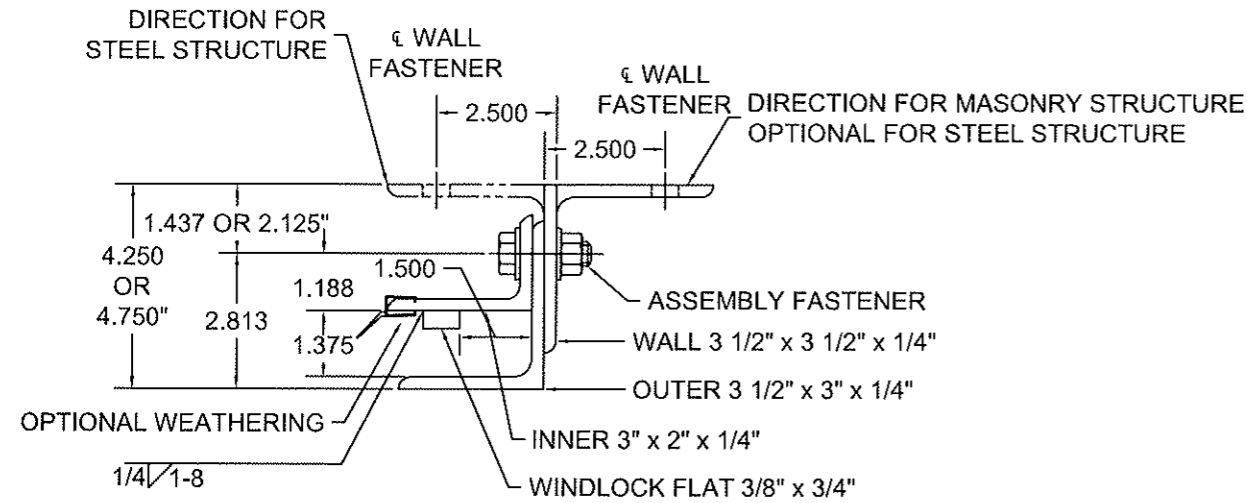

GUIDE ASSEMBLY TYPE DC 1
SCALE: 3" = 1'-0"

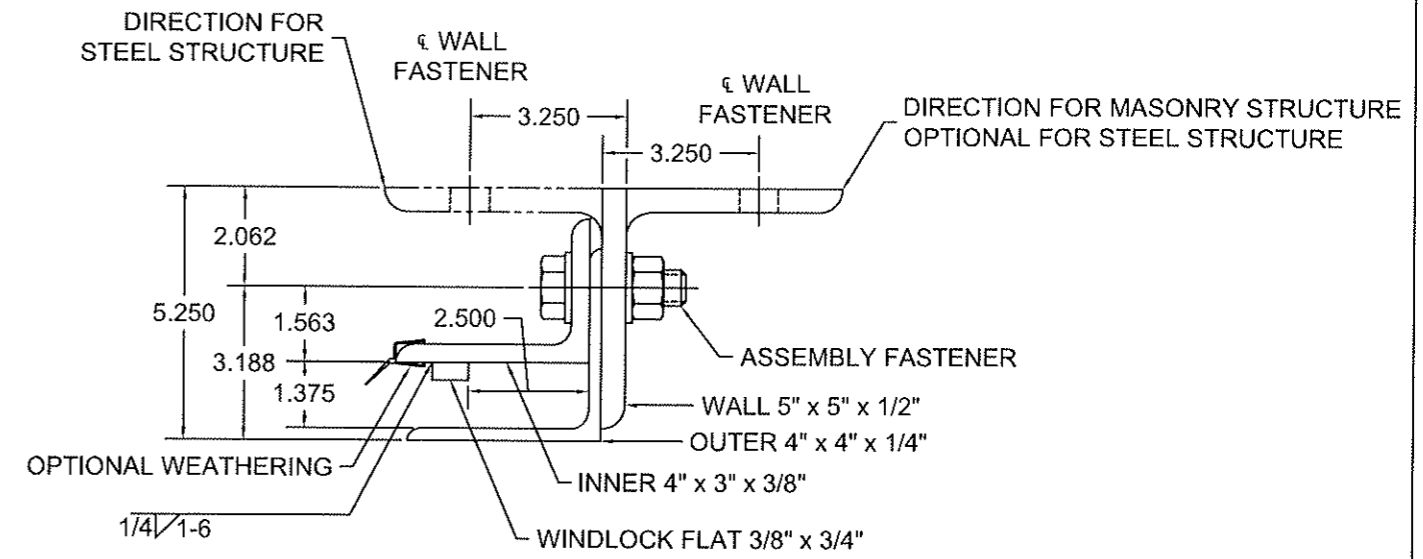

GUIDE ASSEMBLY TYPE DC 2 & DC 3
SCALE: 3" = 1'-0"

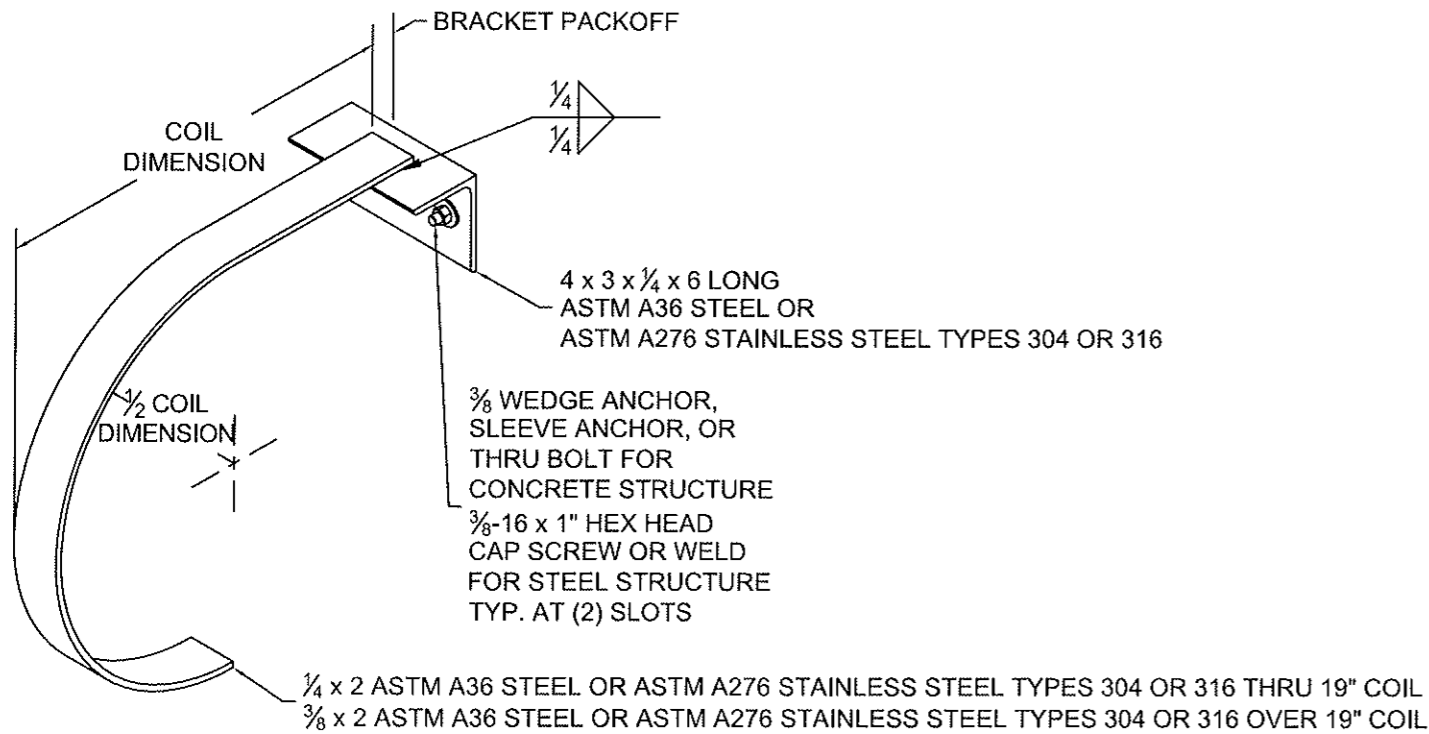

MID-HOOD SUPPORT
(WHEN REQUIRED)

"D" SHAPE DEPICTED, SQUARE STYLE ALSO AVAILABLE
SCALE: NTS

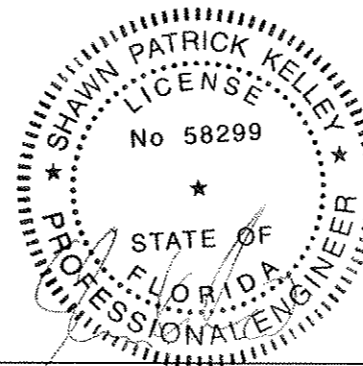

<p>COOKSON THE COOKSON COMPANY, INC.</p>	<p>24 ELMWOOD AVE 1901 S. LITCHFIELD RD MOUNTAINTOP, PA GOODYEAR, AZ 800 TULIP DRIVE GASTONIA, NC P: 800.390.8590 F: 866.448.6798 E: ADS@COOKSONDOOR.COM</p>	<p>Unless otherwise specified, dimensions are in inches & tolerances are: 0.000 = +/- 0.031 FRACTIONAL = +/- 1/32 ANGLES = +/- 1/2 DEG</p>			
		<p>TITLE: WIND LOAD CONFIGURATION NON-INSULATED ROLLING STEEL DOOR CP0020 SLAT IMPACT RATED</p>	<p>DRAWN BY: TJE</p>	<p>SIZE: B</p>	<p>SCALE: AS NOTED</p>
<p>DWG NO: ES-16-60-TCCI</p>					

L'TR	REVISION	DATE	BY	E.C.O.
*	ORIGINAL ISSUE	10/15/14	TJE	1615

CP0020 - 0.0236 Minimum Thickness Galvanized or Stainless Steel - 40 PSF

DBG Up To	Windlock Flat Location	SIP	Windlock	Guide Assembly	Windlock Web Pitch	Assembly Fastener Diameter	Assembly Fastener Spacing	Concrete Minimum 3,000 PSI Compressive Strength (Anchors are the same diameter as assembly fasteners)												Fired CMU						Steel (Wall anchors are the same diameter as assembly fasteners)						Superimposed Loads									
								Hilti Kwik Bolt 3				Simpson Wedge All				Red Head Tru-Bolt				Powers Wedge Bolt				Hilti Kwik Bolt 3			Simpson Strong-Bolt 2			Through Bolt			Welded		Through Bolt		Tapped				
								Max O.C.	Embed	Min. Wall Thk.	Edge Dist.	Max O.C.	Embed	Min. Wall Thk.	Edge Dist.	Max O.C.	Embed	Min. Wall Thk.	Edge Dist.	Max O.C.	Embed	Min. Wall Thk.	Edge Dist.	Max O.C.	Dia.	Embed	Edge Dist.	Max O.C.	Dia.	Embed	Edge Dist.	Max O.C.	Dia.	Embed	Edge Dist.	Max O.C.	Min. Thickness	Vx (1)	Vy (1)	Vx (1)	Vy (1)
5'-5"	N/A	N/A	N/A	333*	N/A	3/8	24	36	2 3/8	4	4 9/16	33	2 5/8	3 15/16	4 9/16	27	3	4 1/2	4 9/16	21	2	3	4 9/16	15	3/8	2 1/2	4 9/16	10	3/8	2 1/2	4 9/16	20	3/8	4 9/16	36	3/8	2 1/2	0	117	0	136

CP0020 - 0.0236 Minimum Thickness Galvanized or Stainless Steel - 50 PSF

DBG Up To	Windlock Flat Location	SIP	Windlock	Guide Assembly	Windlock Web Pitch	Assembly Fastener Diameter	Assembly Fastener Spacing	Concrete Minimum 3,000 PSI Compressive Strength (Anchors are the same diameter as assembly fasteners)												Fired CMU						Steel (Wall anchors are the same diameter as assembly fasteners)						Superimposed Loads									
								Hilti Kwik Bolt 3				Simpson Wedge All				Red Head Tru-Bolt				Powers Wedge Bolt				Hilti Kwik Bolt 3			Simpson Strong-Bolt 2			Through Bolt			Welded		Through Bolt		Tapped				
								Max O.C.	Embed	Min. Wall Thk.	Edge Dist.	Max O.C.	Embed	Min. Wall Thk.	Edge Dist.	Max O.C.	Embed	Min. Wall Thk.	Edge Dist.	Max O.C.	Embed	Min. Wall Thk.	Edge Dist.	Max O.C.	Dia.	Embed	Edge Dist.	Max O.C.	Dia.	Embed	Edge Dist.	Max O.C.	Dia.	Embed	Edge Dist.	Max O.C.	Min. Thickness	Vx (1)	Vy (1)	Vx (1)	Vy (1)
5'-5"	N/A	N/A	N/A	333*	N/A	3/8	24	36	2 3/8	4	4 9/16	33	2 5/8	3 15/16	4 9/16	27	3	4 1/2	4 9/16	21	2	3	4 9/16	15	3/8	2 1/2	4 9/16	10	3/8	2 1/2	4 9/16	20	3/8	4 9/16	36	3/8	2 1/2	0	137	0	136

CP0020 - 0.0236 Minimum Thickness Galvanized or Stainless Steel - 60 PSF

DBG Up To	Windlock Flat Location	SIP	Windlock	Guide Assembly	Windlock Web Pitch	Assembly Fastener Diameter	Assembly Fastener Spacing	Concrete Minimum 3,000 PSI Compressive Strength (Anchors are the same diameter as assembly fasteners)												Fired CMU						Steel (Wall anchors are the same diameter as assembly fasteners)						Superimposed Loads									
								Hilti Kwik Bolt 3				Simpson Wedge All				Red Head Tru-Bolt				Powers Wedge Bolt				Hilti Kwik Bolt 3			Simpson Strong-Bolt 2			Through Bolt			Welded		Through Bolt		Tapped				
								Max O.C.	Embed	Min. Wall Thk.	Edge Dist.	Max O.C.	Embed	Min. Wall Thk.	Edge Dist.	Max O.C.	Embed	Min. Wall Thk.	Edge Dist.	Max O.C.	Embed	Min. Wall Thk.	Edge Dist.	Max O.C.	Dia.	Embed	Edge Dist.	Max O.C.	Dia.	Embed	Edge Dist.	Max O.C.	Dia.	Embed	Edge Dist.	Max O.C.	Min. Thickness	Vx (1)	Vy (1)	Vx (1)	Vy (1)
4'-5"	N/A	N/A	N/A	333*	N/A	3/8	24	36	2 3/8	4	4 9/16	27	2 5/8	3 15/16	4 9/16	28	3	4 1/2	4 9/16	21	2	3	4 9/16	15	3/8	1 5/8	4 9/16	10	3/8	2 1/2	5 3/4	27	3/8	4 9/16	36	3/8	2 1/2	0	135	0	133



24 ELMWOOD AVE 1901 S. LITCHFIELD RD
MOUNTAINTOP, PA GOODYEAR, AZ
800 TULIP DRIVE
GASTONIA, NC
P: 800.390.8590
F: 866.448.6798
E: ADS@COOKSONDOOR.COM

Unless otherwise specified, dimensions are in inches & tolerances are:
0.000 = +/- 0.031
FRACTIONAL = +/- 1/32
ANGLES = +/- 1/2 DEG

TITLE: WIND LOAD CONFIGURATION NON-INSULATED ROLLING STEEL DOOR CP0020 SLAT IMPACT RATED	DRAWN BY: TJE	SIZE: B	SCALE: AS NOTED	SHEET: 11/19
DWG NO: ES-16-60-TCCI				

L'TR	REVISION	DATE	BY	E.C.O.
*	ORIGINAL ISSUE	10/15/14	TJE	1615

CP0020 - 0.0236 Minimum Thickness Galvanized or Stainless Steel - 65 PSF																																															
DWS Up To	Windlock Flat Location	Slip	Windlock	Code Assembly	Windlock Weld Pitch	Assembly Fastener Diameter	Assembly Fastener Spacing	Concrete Minimum 3,000 PSI Compressive Strength (Anchors are the same diameter as assembly fasteners)												Fibred CMU												Steel (W20 anchors are the same diameter as assembly fasteners)			Superimposed Loads												
								Hilti Kwik Bolt 3				Simpson Wedge All				Red Head Tri-Bolt				Powers Wedge-Bolt				FERI Kwik Bolt 3				Simpson Strong-Bolt 2				Through Bolt			Welded			Tapped									
								Max O.C.	Embed	Min. Wall Thick.	Edge Dist.	Max O.C.	Embed	Min. Wall Thick.	Edge Dist.	Max O.C.	Embed	Min. Wall Thick.	Edge Dist.	Max O.C.	Embed	Min. Wall Thick.	Edge Dist.	Max O.C.	Dia.	Embed	Edge Dist.	Max O.C.	Dia.	Embed	Edge Dist.	Max O.C.	Dia.	Edge Dist.	Max O.C.	Slot Size	Max O.C.	Min. Thickness	Vx (+)	Vy (+)	Vx (-)	Vy (-)					
4'-5"	N/A	N/A	N/A	333*	N/A	3/8	24	36	2 3/8	4	4 9/16	25	2 5/8	3 15/16	4 9/16	28	3	4 1/2	4 9/16	20	2	3	4 9/16	14	3/8	1 5/8	4 9/16	10	3/8	2 5/8	4 9/16	25	3/8	4 9/16	36	7/16 x 5/8	36	36	3/16	0	145	0	144				
4'-5"	N/A	N/A	N/A	344*	N/A	3/8	24	36	2 3/8	4	5 3/4	14	2 5/8	3 15/16	5 3/4	14	3	4 1/2	5 3/4	28	3 1/2	5 1/4	5 3/4	8	3/8	2 1/2	5 3/4	13	3/4	5 1/4	5 3/4	14	3/8	5 3/4	36	36	3/16	0	147	0	144						
14'-5"	1 1/2	0.656	CP1152 & CP1153	DC1	6	1/2	12	8	3 1/2	5 1/4	5 3/4	8	4 1/2	6 3/4	5 3/4	N/A	N/A	N/A	N/A	N/A	N/A	N/A	N/A	N/A	N/A	N/A	N/A	N/A	N/A	N/A	N/A	N/A	N/A	N/A	N/A	N/A	N/A	N/A	N/A	N/A	N/A	N/A	N/A	N/A			
15'-5"	1 1/2	0.656	CP1152 & CP1153	54C	6	5/8	17	N/A	N/A	N/A	N/A	N/A	N/A	N/A	N/A	N/A	N/A	N/A	N/A	N/A	N/A	N/A	N/A	N/A	N/A	N/A	N/A	N/A	N/A	N/A	N/A	N/A	N/A	N/A	N/A	N/A	N/A	N/A	N/A	N/A	N/A	N/A	N/A	N/A			
16'-5"	1 5/8	0.781	CP1152 & CP1153	54C	6	5/8	16	N/A	N/A	N/A	N/A	N/A	N/A	N/A	N/A	N/A	N/A	N/A	N/A	N/A	N/A	N/A	N/A	N/A	N/A	N/A	N/A	N/A	N/A	N/A	N/A	N/A	N/A	N/A	N/A	N/A	N/A	N/A	N/A	N/A	N/A	N/A	N/A	N/A	N/A		
17'-5"	1 5/8	0.906	CP1152 & CP1153	54C	6	5/8	15	N/A	N/A	N/A	N/A	N/A	N/A	N/A	N/A	N/A	N/A	N/A	N/A	N/A	N/A	N/A	N/A	N/A	N/A	N/A	N/A	N/A	N/A	N/A	N/A	N/A	N/A	N/A	N/A	N/A	N/A	N/A	N/A	N/A	N/A	N/A	N/A	N/A	N/A	N/A	
18'-5"	2	1.156	CP1152 & CP1153	54C	6	5/8	16	N/A	N/A	N/A	N/A	N/A	N/A	N/A	N/A	N/A	N/A	N/A	N/A	N/A	N/A	N/A	N/A	N/A	N/A	N/A	N/A	N/A	N/A	N/A	N/A	N/A	N/A	N/A	N/A	N/A	N/A	N/A	N/A	N/A	N/A	N/A	N/A	N/A	N/A	N/A	N/A
19'-5"	2	1.358	CP1152 & CP1153	54C	6	5/8	14	N/A	N/A	N/A	N/A	N/A	N/A	N/A	N/A	N/A	N/A	N/A	N/A	N/A	N/A	N/A	N/A	N/A	N/A	N/A	N/A	N/A	N/A	N/A	N/A	N/A	N/A	N/A	N/A	N/A	N/A	N/A	N/A	N/A	N/A	N/A	N/A	N/A	N/A	N/A	N/A
20'-5"	2 3/8	1.531	CP1152 & CP1153	64B	6	3/4	18	N/A	N/A	N/A	N/A	N/A	N/A	N/A	N/A	N/A	N/A	N/A	N/A	N/A	N/A	N/A	N/A	N/A	N/A	N/A	N/A	N/A	N/A	N/A	N/A	N/A	N/A	N/A	N/A	N/A	N/A	N/A	N/A	N/A	N/A	N/A	N/A	N/A	N/A	N/A	N/A
21'-5"	2 1/2	1.656	CP1152 & CP1153	64B	6	3/4	18	N/A	N/A	N/A	N/A	N/A	N/A	N/A	N/A	N/A	N/A	N/A	N/A	N/A	N/A	N/A	N/A	N/A	N/A	N/A	N/A	N/A	N/A	N/A	N/A	N/A	N/A	N/A	N/A	N/A	N/A	N/A	N/A	N/A	N/A	N/A	N/A	N/A	N/A	N/A	N/A
22'-5"	2 1/2	1.656	CP1152 & CP1153	64B	6	3/4	18	N/A	N/A	N/A	N/A	N/A	N/A	N/A	N/A	N/A	N/A	N/A	N/A	N/A	N/A	N/A	N/A	N/A	N/A	N/A	N/A	N/A	N/A	N/A	N/A	N/A	N/A	N/A	N/A	N/A	N/A	N/A	N/A	N/A	N/A	N/A	N/A	N/A	N/A	N/A	N/A
23'-5"	2 1/2	1.656	CP1152 & CP1153	64B	6	3/4	18	N/A	N/A	N/A	N/A	N/A	N/A	N/A	N/A	N/A	N/A	N/A	N/A	N/A	N/A	N/A	N/A	N/A	N/A	N/A	N/A	N/A	N/A	N/A	N/A	N/A	N/A	N/A	N/A	N/A	N/A	N/A	N/A	N/A	N/A	N/A	N/A	N/A	N/A	N/A	N/A
24'-5"	2 1/2	1.656	CP1152 & CP1153	64B	6	3/4	17	N/A	N/A	N/A	N/A	N/A	N/A	N/A	N/A	N/A	N/A	N/A	N/A	N/A	N/A	N/A	N/A	N/A	N/A	N/A	N/A	N/A	N/A	N/A	N/A	N/A	N/A	N/A	N/A	N/A	N/A	N/A	N/A	N/A	N/A	N/A	N/A	N/A	N/A	N/A	N/A

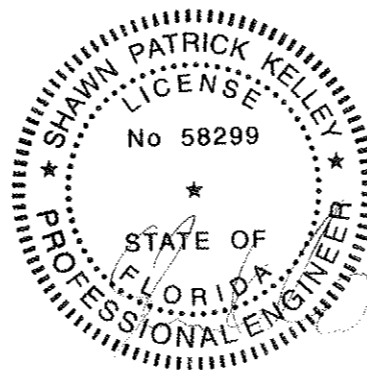

 <p>COOKSON THE COOKSON COMPANY, INC.</p>	24 ELMWOOD AVE 1901 S. LITCHFIELD RD MOUNTAINTOP, PA GOODYEAR, AZ 800 TULIP DRIVE GASTONIA, NC P: 800.390.8590 F: 866.448.6798 E: ADS@COOKSONDOOR.COM	Unless otherwise specified, dimensions are in inches & tolerances are: 0.000 = +/- 0.031 FRACTIONAL = +/- 1/32 ANGLES = +/- 1/2 DEG		
		TITLE: WIND LOAD CONFIGURATION NON-INSULATED ROLLING STEEL DOOR CP0020 SLAT IMPACT RATED	DRAWN BY: TJE	SIZE: B
		DWG NO: ES-16-60-TCCI		

L'TR	REVISION	DATE	BY	E.C.O.
*	ORIGINAL ISSUE	10/15/14	TJE	1615

DBG Up To	Windlock Flat Location	Slip	Windlock	Guide Assembly	Windlock Weld Pitch	Assembly Fastener Diameter	Assembly Fastener Spacing	Concrete Minimum 3,000 PSI Compressive Strength (Anchors are the same diameter as assembly fasteners)												Fitted CMU						Steel (Wall anchors are the same diameter as assembly fasteners)						Superimposed Loads															
								Hilti Kwik Bolt 3			Simpson Wedge All			Red Head Tri-Bolt			Powers Wedge-Bolt			Hilti Kwik Bolt 3			Simpson Strong-Bolt 2			Through Bolt			Welded			Through Bolt			Tapped												
								Max O.C.	Embed	Min. Wall Thick.	Edge Dist.	Max O.C.	Embed	Min. Wall Thick.	Edge Dist.	Max O.C.	Embed	Min. Wall Thick.	Edge Dist.	Max O.C.	Embed	Min. Wall Thick.	Edge Dist.	Max O.C.	Embed	Min. Wall Thick.	Edge Dist.	Max O.C.	Embed	Min. Wall Thick.	Edge Dist.	Max O.C.	Embed	Min. Wall Thick.	Edge Dist.	Max O.C.	Embed	Min. Wall Thick.	Edge Dist.	Max O.C.	Embed	Min. Wall Thick.	Edge Dist.	Max O.C.	Embed	Min. Wall Thick.	Edge Dist.
4'-5"	N/A	N/A	N/A	333*	N/A	3/8	24	36	2 3/8	4	4 9/16	25	2 5/8	3 15/16	4 9/16	26	3	4 1/2	4 9/16	20	2	3	4 9/16	14	3/8	2 1/2	4 9/16	10	3/8	2 5/8	4 9/16	25	3/8	4 9/16	36	3/8	4 9/16	36	3/8	4 9/16	0	146	0	144			

DBG Up To	Windlock Flat Location	Slip	Windlock	Guide Assembly	Windlock Weld Pitch	Assembly Fastener Diameter	Assembly Fastener Spacing	Concrete Minimum 3,000 PSI Compressive Strength (Anchors are the same diameter as assembly fasteners)												Fitted CMU						Steel (Wall anchors are the same diameter as assembly fasteners)						Superimposed Loads															
								Hilti Kwik Bolt 3			Simpson Wedge All			Red Head Tri-Bolt			Powers Wedge-Bolt			Hilti Kwik Bolt 3			Simpson Strong-Bolt 2			Through Bolt			Welded			Through Bolt			Tapped												
								Max O.C.	Embed	Min. Wall Thick.	Edge Dist.	Max O.C.	Embed	Min. Wall Thick.	Edge Dist.	Max O.C.	Embed	Min. Wall Thick.	Edge Dist.	Max O.C.	Embed	Min. Wall Thick.	Edge Dist.	Max O.C.	Embed	Min. Wall Thick.	Edge Dist.	Max O.C.	Embed	Min. Wall Thick.	Edge Dist.	Max O.C.	Embed	Min. Wall Thick.	Edge Dist.	Max O.C.	Embed	Min. Wall Thick.	Edge Dist.	Max O.C.	Embed	Min. Wall Thick.	Edge Dist.	Max O.C.	Embed	Min. Wall Thick.	Edge Dist.
4'-5"	N/A	N/A	N/A	333*	N/A	3/8	24	36	2 3/8	4	4 9/16	23	2 5/8	3 15/16	4 9/16	24	3	4 1/2	4 9/16	18	2	3	4 9/16	13	3/8	2 1/2	4 9/16	9	3/8	2 5/8	4 9/16	23	3/8	4 9/16	36	3/8	4 9/16	36	3/8	4 9/16	0	157	0	155			

DBG Up To	Windlock Flat Location	Slip	Windlock	Guide Assembly	Windlock Weld Pitch	Assembly Fastener Diameter	Assembly Fastener Spacing	Concrete Minimum 3,000 PSI Compressive Strength (Anchors are the same diameter as assembly fasteners)												Fitted CMU						Steel (Wall anchors are the same diameter as assembly fasteners)						Superimposed Loads															
								Hilti Kwik Bolt 3			Simpson Wedge All			Red Head Tri-Bolt			Powers Wedge-Bolt			Hilti Kwik Bolt 3			Simpson Strong-Bolt 2			Through Bolt			Welded			Through Bolt			Tapped												
								Max O.C.	Embed	Min. Wall Thick.	Edge Dist.	Max O.C.	Embed	Min. Wall Thick.	Edge Dist.	Max O.C.	Embed	Min. Wall Thick.	Edge Dist.	Max O.C.	Embed	Min. Wall Thick.	Edge Dist.	Max O.C.	Embed	Min. Wall Thick.	Edge Dist.	Max O.C.	Embed	Min. Wall Thick.	Edge Dist.	Max O.C.	Embed	Min. Wall Thick.	Edge Dist.	Max O.C.	Embed	Min. Wall Thick.	Edge Dist.	Max O.C.	Embed	Min. Wall Thick.	Edge Dist.	Max O.C.	Embed	Min. Wall Thick.	Edge Dist.
4'-5"	N/A	N/A	N/A	333*	N/A	3/8	24	36	2 3/8	4	4 9/16	20	2 5/8	3 15/16	4 9/16	21	3	4 1/2	4 9/16	16	2	3	4 9/16	11	3/8	2 1/2	4 9/16	8	3/8	2 5/8	4 9/16	20	3/8	4 9/16	36	3/8	4 9/16	36	3/8	4 9/16	0	180	0	177			

DBG Up To	Windlock Flat Location	Slip	Windlock	Guide Assembly	Windlock Weld Pitch	Assembly Fastener Diameter	Assembly Fastener Spacing	Concrete Minimum 3,000 PSI Compressive Strength (Anchors are the same diameter as assembly fasteners)												Fitted CMU						Steel (Wall anchors are the same diameter as assembly fasteners)						Superimposed Loads															
								Hilti Kwik Bolt 3			Simpson Wedge All			Red Head Tri-Bolt			Powers Wedge-Bolt			Hilti Kwik Bolt 3			Simpson Strong-Bolt 2			Through Bolt			Welded			Through Bolt			Tapped												
								Max O.C.	Embed	Min. Wall Thick.	Edge Dist.	Max O.C.	Embed	Min. Wall Thick.	Edge Dist.	Max O.C.	Embed	Min. Wall Thick.	Edge Dist.	Max O.C.	Embed	Min. Wall Thick.	Edge Dist.	Max O.C.	Embed	Min. Wall Thick.	Edge Dist.	Max O.C.	Embed	Min. Wall Thick.	Edge Dist.	Max O.C.	Embed	Min. Wall Thick.	Edge Dist.	Max O.C.	Embed	Min. Wall Thick.	Edge Dist.	Max O.C.	Embed	Min. Wall Thick.	Edge Dist.	Max O.C.	Embed	Min. Wall Thick.	Edge Dist.
4'-5"	N/A	N/A	N/A	333*	N/A	3/8	24	36	2 3/8	4	4 9/16	18	2 5/8	3 15/16	4 9/16	18	3	4 1/2	4 9/16	14	2	3	4 9/16	10	3/8	2 1/2	4 9/16	8	3/8	2 5/8	4 9/16	20	3/8	4 9/16	36	3/8	4 9/16	36	3/8	4 9/16	0	202	0	199			

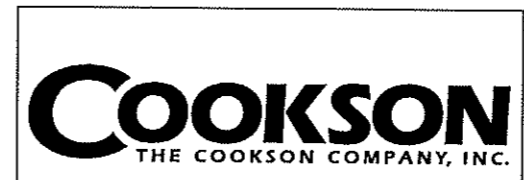
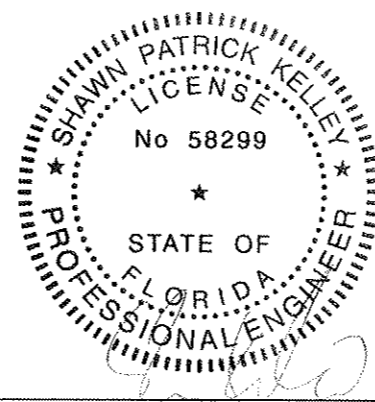

24 ELMWOOD AVE 1901 S. LITCHFIELD RD
 MOUNTAINTOP, PA GOODYEAR, AZ
 800 TULIP DRIVE
 GASTONIA, NC
 P: 800.390.8590
 F: 866.448.6798
 E: ADS@COOKSONDOOR.COM

Unless otherwise specified, dimensions are in inches & tolerances are:
 0.000 = +/- 0.031
 FRACTIONAL = +/- 1/32
 ANGLES = +/- 1/2 DEG

TITLE: WIND LOAD CONFIGURATION
 NON-INSULATED ROLLING STEEL DOOR
 CP0020 SLAT IMPACT RATED

DRAWN BY: TJE
 SIZE: B
 SCALE: AS NOTED
 SHEET: 15/19
 DWG NO: ES-16-60-TCCI

D&G Up To	Windlock Flat Location	Slip	Windlock	Guide Assembly	Windlock Weld Pitch	Assembly Fastener Diameter	Assembly Fastener Spacing	Concrete Minimum 3,000 PSI Compressive Strength (Anchors are the same diameter as assembly fasteners)												Fitted CMU										Steel (Wall anchors are the same diameter as assembly fasteners)						Superimposed Loads													
								Hilti Kwik Bolt 3				Simpson Wedge AN				Red Head Tri-Bolt				Powers Wedge-Bolt				Hilti Kwik Bolt 3			Simpson Strong-Bolt 2			Through Bolt		Welded	Through Bolt	Tapped	Vx (+)	Vy (+)	Vx (-)	Vy (-)											
								Max O.C.	Embed	Min. Wall Thick.	Edge Dist	Max O.C.	Embed	Min. Wall Thick.	Edge Dist	Max O.C.	Embed	Min. Wall Thick.	Edge Dist	Max O.C.	Embed	Min. Wall Thick.	Edge Dist	Max O.C.	Dia.	Embed	Edge Dist	Max O.C.	Dia.	Embed	Edge Dist	Max O.C.	Dia.	Edge Distance					Max O.C.	Min. Thickness									
5'-5"	N/A	N/A	N/A	333*	N/A	3/8	24	36	2 3/8	4	4 9/16	20	2 5/8	3 15/16	4 9/16	21	3	4 1/2	4 9/16	15	2	3	4 9/16	11	3/8	2 1/2	4 9/16	8	3/8	2 1/2	4 9/16	10	3/4	5 3/4	10	3/4	5 3/4	11	3/8	4 9/16	36	7/16 x 5/8	36	36	3/16	0	179	0	177

D&G Up To	Windlock Flat Location	Slip	Windlock	Guide Assembly	Windlock Weld Pitch	Assembly Fastener Diameter	Assembly Fastener Spacing	Concrete Minimum 3,000 PSI Compressive Strength (Anchors are the same diameter as assembly fasteners)												Fitted CMU										Steel (Wall anchors are the same diameter as assembly fasteners)						Superimposed Loads													
								Hilti Kwik Bolt 3				Simpson Wedge AN				Red Head Tri-Bolt				Powers Wedge-Bolt				Hilti Kwik Bolt 3			Simpson Strong-Bolt 2			Through Bolt		Welded	Through Bolt	Tapped	Vx (+)	Vy (+)	Vx (-)	Vy (-)											
								Max O.C.	Embed	Min. Wall Thick.	Edge Dist	Max O.C.	Embed	Min. Wall Thick.	Edge Dist	Max O.C.	Embed	Min. Wall Thick.	Edge Dist	Max O.C.	Embed	Min. Wall Thick.	Edge Dist	Max O.C.	Dia.	Embed	Edge Dist	Max O.C.	Dia.	Embed	Edge Dist	Max O.C.	Dia.	Edge Distance					Max O.C.	Min. Thickness									
5'-5"	N/A	N/A	N/A	333*	N/A	3/8	24	36	2 3/8	4	4 9/16	20	2 5/8	3 15/16	4 9/16	21	3	4 1/2	4 9/16	15	2	3	4 9/16	11	3/8	2 1/2	4 9/16	8	3/8	2 1/2	4 9/16	10	3/4	5 3/4	10	3/4	5 3/4	11	3/8	4 9/16	36	7/16 x 5/8	36	36	3/16	0	192	0	190

D&G Up To	Windlock Flat Location	Slip	Windlock	Guide Assembly	Windlock Weld Pitch	Assembly Fastener Diameter	Assembly Fastener Spacing	Concrete Minimum 3,000 PSI Compressive Strength (Anchors are the same diameter as assembly fasteners)												Fitted CMU										Steel (Wall anchors are the same diameter as assembly fasteners)						Superimposed Loads													
								Hilti Kwik Bolt 3				Simpson Wedge AN				Red Head Tri-Bolt				Powers Wedge-Bolt				Hilti Kwik Bolt 3			Simpson Strong-Bolt 2			Through Bolt		Welded	Through Bolt	Tapped	Vx (+)	Vy (+)	Vx (-)	Vy (-)											
								Max O.C.	Embed	Min. Wall Thick.	Edge Dist	Max O.C.	Embed	Min. Wall Thick.	Edge Dist	Max O.C.	Embed	Min. Wall Thick.	Edge Dist	Max O.C.	Embed	Min. Wall Thick.	Edge Dist	Max O.C.	Dia.	Embed	Edge Dist	Max O.C.	Dia.	Embed	Edge Dist	Max O.C.	Dia.	Edge Distance					Max O.C.	Min. Thickness									
5'-5"	N/A	N/A	N/A	333*	N/A	3/8	24	36	2 3/8	4	4 9/16	16	2 5/8	3 15/16	4 9/16	17	3	4 1/2	4 9/16	13	2	3	4 9/16	9	3/8	2 1/2	4 9/16	8	3/8	2 1/2	4 9/16	11	3/4	5 3/4	11	3/4	5 3/4	11	3/8	4 9/16	36	7/16 x 5/8	36	36	3/16	0	220	0	217

D&G Up To	Windlock Flat Location	Slip	Windlock	Guide Assembly	Windlock Weld Pitch	Assembly Fastener Diameter	Assembly Fastener Spacing	Concrete Minimum 3,000 PSI Compressive Strength (Anchors are the same diameter as assembly fasteners)												Fitted CMU										Steel (Wall anchors are the same diameter as assembly fasteners)						Superimposed Loads													
								Hilti Kwik Bolt 3				Simpson Wedge AN				Red Head Tri-Bolt				Powers Wedge-Bolt				Hilti Kwik Bolt 3			Simpson Strong-Bolt 2			Through Bolt		Welded	Through Bolt	Tapped	Vx (+)	Vy (+)	Vx (-)	Vy (-)											
								Max O.C.	Embed	Min. Wall Thick.	Edge Dist	Max O.C.	Embed	Min. Wall Thick.	Edge Dist	Max O.C.	Embed	Min. Wall Thick.	Edge Dist	Max O.C.	Embed	Min. Wall Thick.	Edge Dist	Max O.C.	Dia.	Embed	Edge Dist	Max O.C.	Dia.	Embed	Edge Dist	Max O.C.	Dia.	Edge Distance					Max O.C.	Min. Thickness									
4'-5"	N/A	N/A	N/A	333*	N/A	3/8	24	36	2 3/8	4	4 9/16	18	2 5/8	3 15/16	4 9/16	18	3	4 1/2	4 9/16	14	2	3	4 9/16	10	3/8	2 1/2	4 9/16	8	3/8	2 1/2	4 9/16	10	3/4	5 3/4	10	3/4	5 3/4	11	3/8	4 9/16	36	7/16 x 5/8	36	36	3/16	0	202	0	199

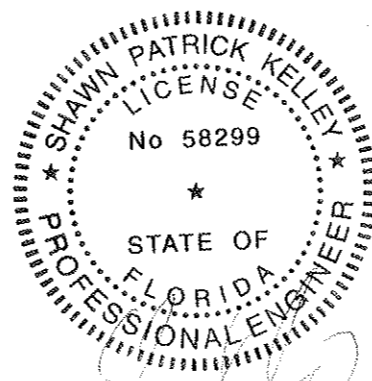

24 ELMWOOD AVE 1901 S. LITCHFIELD RD
MOUNTAINTOP, PA GOODYEAR, AZ
800 TULIP DRIVE
GASTONIA, NC
P: 800.390.8590
F: 866.448.6798
E: ADS@COOKSONDOOR.COM

Unless otherwise specified, dimensions are in inches & tolerances are:
0.000 = +/- 0.031
FRACTIONAL = +/- 1/32
ANGLES = +/- 1/2 DEG

TITLE: WIND LOAD CONFIGURATION
NON-INSULATED ROLLING STEEL DOOR
CP0020 SLAT IMPACT RATED

DRAWN BY: TJE
SIZE: B
SCALE: AS NOTED
SHEET: 18/19
DWG NO: ES-16-60-TCCI

L'TR	REVISION	DATE	BY	E.C.O.
*	ORIGINAL ISSUE	10/15/14	TJE	1615

Dwg Up To	Windlock Fit Location	Slp	Windlock	Guide Assembly	Windlock Weld Patch	Assembly Fastener Diameter	Assembly Fastener Spacing	Concrete Minimum 3,000 PSI Compressive Strength (Anchors are the same diameter as assembly fasteners)												Filled CMU												Steel (Wall anchors are the same diameter as assembly fasteners)				Superimposed Loads							
								Hilti Kwik Bolt 3				Simpson Wedge All				Red Head Tra-Bolt				Powers Wedge Bolt				Hilti Kwik Bolt 3				Simpson Strong-Bolt 2				Through Bolt		Welded		Tapped							
								Max O.C.	Embed	Min. Wall Thick.	Edge Dist	Max O.C.	Embed	Min. Wall Thick.	Edge Dist	Max O.C.	Embed	Min. Wall Thick.	Edge Dist	Max O.C.	Embed	Min. Wall Thick.	Edge Dist	Max O.C.	Dia.	Embed	Edge Dist	Max O.C.	Dia.	Embed	Edge Dist	Max O.C.	Dia.	Edge Distance	Max O.C.	Slot Size	Max O.C.	Min. Thickness	Vx (+)	Vy (+)	Vx (-)	Vy (-)	
4'-5"	N/A	N/A	N/A	333*	N/A	3/8	24	25	2 3/8	4	4 9/16	16	2 5/8	3 15/16	4 9/16	16	3	4 1/2	4 9/16	18	2	3	4 9/16	9	3/8	2 1/2	4 9/16	15	3/4	5 1/4	4 9/16	16	3/8	4 9/16	36	7/16 x 5/8	36	36	3/16	0	224	0	221
4'-5"	N/A	N/A	N/A	342*	N/A	3/8	24																																				
14'-5"	1 1/2	0.656	CP1152 & CP1153	648	5	3/4	18																																				
15'-5"	1 5/8	0.783	CP1152 & CP1153	648	5	3/4	17																																				
19'-5"	1 3/4	0.906	CP1152 & CP1153	648	5	3/4	17																																				
17'-5"	2	1.156	CP1152 & CP1153	648	5	3/4	16																																				
18'-5"	2 1/4	1.406	CP1152 & CP1153	648	5	3/4	16																																				
19'-5"	2 1/2	1.656	CP1152 & CP1153	648	5	3/4	15																																				

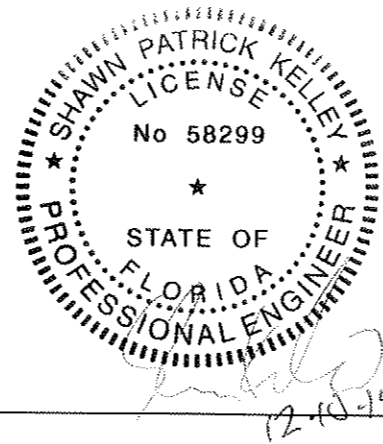

 THE COOKSON COMPANY, INC.	24 ELMWOOD AVE 1901 S. LITCHFIELD RD MOUNTAINTOP, PA GOODYEAR, AZ 800 TULIP DRIVE GASTONIA, NC P: 800.390.8590 F: 866.448.6798 E: ADS@COOKSONDOOR.COM	Unless otherwise specified, dimensions are in inches & tolerances are: 0.000 = +/- 0.031 FRACTIONAL = +/- 1/32 ANGLES = +/- 1/2 DEG
DWG NO: ES-16-60-TCCI		