



EVALUATION SUBJECT: SIMPSON STRONG-TIE® MISCELLANEOUS CONNECTORS

REPORT HOLDER:

Simpson Strong-Tie Company Inc.
5956 West Las Positas Boulevard
Pleasanton, CA 94588
(800) 999-5099
www.strongtie.com

CSI Division: 06—WOOD, PLASTIC, and
COMPOSITES
CSI Section: 06 05 23—Wood, Plastic, and Composite
Fastenings

1.0 SCOPE OF EVALUATION

1.1 Compliance to the following codes & regulations:

- 2015, 2012, 2009 and 2006 International Building Code® (IBC)
- 2015, 2012, 2009 and 2006 International Residential Code® (IRC)

1.2 Evaluated in accordance with:

- IAPMO UES EC 002-2017
- ICC-ES AC13

1.3 Properties assessed:

- Structural

2.0 PRODUCT USE

Simpson Strong-Tie® miscellaneous connectors are used as wood framing connectors in accordance with Section [2304.9.3](#) of the IBC. The products may be used in structures regulated under the IRC when an engineered design is submitted in accordance with Section [R301.1.3](#) of the IRC.

3.0 PRODUCT DESCRIPTION

3.1 Product Information

3.1.1 RTC Rigid Tie Connectors Series: The RTC Rigid Tie connectors are used to attach two horizontal wood joist members to a vertical post forming a 90 degree corner. The RTC2Z, RTC2Z and RTC42 are fabricated from No. 18 gage steel, and the RTC44 is fabricated from No. 14 gage steel. [Table 1](#) and [Figure 1](#) of this report provide required member sizes, fastener schedules, allowable loads, connector dimensions, and a typical installation detail.

3.1.2 LSCZ Adjustable Stringer Connector: The LSCZ adjustable stringer connector is a concealed connector used to attach a stair stringer to a supporting header or rim joist. The LSCZ is field-adjusted with a one-time bend at the designated bend line to accommodate variable stair stringer pitches.

The LSCZ may be used with either solid or notched stair stringers. The LSCZ is fabricated from No. 18 gage steel. [Table 2](#) and [Figure 2](#) of this report provide required member sizes, fastener schedules, allowable loads, connector dimensions, and installation details.

3.1.3 DJT14 Deck Joist Tie: DJT14 Deck Joist Tie connector is used to attach joists to posts and is fabricated from No. 14 gage steel. [Table 3](#) and [Figure 3](#) of this report provide fastener schedules, allowable loads, connector dimensions, and a typical installation detail.

3.1.4 CJTZ and HCJTZ Connectors: The CJTZ and HCJTZ connectors are T-shaped connectors used to provide a concealed connection between a joist and supporting header or post. The CJTZ is fabricated from No. 12 gage steel. The HCJTZ is fabricated from No. 10 gage steel. The CJTZ and HCJTZ connectors are attached to a supporting wood member with SDS wood screws and to the routed end of a joist using steel pins with chamfered ends. [Table 4](#) and [Figure 4](#) of this report provide model numbers, required member sizes, fastener schedules, allowable loads, connector and component dimensions, and installation details.

3.1.5 DS Drywall Stops: The DS Drywall Stops are used as backing support for gypsum wallboard edges at wall corners and wall ceiling intersections and is fabricated from No. 20 gage steel. Use of the DS Drywall Stops is limited to nonfire-resistance-rated construction and to nonstructural applications. The DS Drywall Stops shall not be used in wall construction designated as braced wall panels conforming to Section 2308.6 of the 2015 IBC, Section [2308.9.3](#) of the 2012 IBC, Section [R602.10.1](#) of the 2015 and 2012 IRC, Section [R602.10.1.1](#) of the 2009 IRC, or Section [R602.10.3](#) of the 2006 IRC. [Table 5](#) and [Figure 5](#) of this report provide fastener and spacing schedules, connector dimensions and a typical installation detail.

3.1.6 HTC4 Truss Clips: HTC4 truss clips are used as alignment control between a roof truss and a non-gravity-load bearing walls. The 1½ inch-long (38.1 mm) slot permits vertical truss chord movement. HTC connectors are formed from No. 18 gage galvanized steel. [Figure 6](#) and [Table 6](#) of this report provide dimensions, required fasteners, and allowable loads.





3.1.7 KBS1Z Knee-Brace Stabilizer: The KBS1Z knee-brace stabilizer is an adjustable connector used to attach a knee-brace to a post or beam. The KBS1Z may also be used to attach a beam to a post in either a continuous or end condition. The KBS1Z is field-adjusted with a one-time bend at the designated bend line to accommodate variable angles of the knee-brace. The KBS1Z is fabricated from No. 16 gage steel. [Table 7](#) and [Figure 7](#) of this report provide fastener schedules, allowable loads, component dimensions and installation details.

3.1.8 CBTZ Connector: The CBTZ connector is a round, tube-shaped connector used to provide a concealed connection between a beam and supporting post, and is fabricated from No. 12 gage steel. The CBTZ connector is attached to beam and post wood members with steel pins with chamfered ends. [Table 8](#) and [Figure 8](#) of this report provide model numbers, required member sizes, fastener schedules, allowable loads, connector and component dimensions, and installation details.

3.1.9 AP Connectors: The APL, APT, APA, APDJT, APB, APA21, APLH, and APHH are decorative connectors attached to wood members. The APL, APT, APA, APDJT, and APB use the Simpson Strong-Tie SDWS22312DBB or SDWS22512DBB wood screws inserted through the STN22 Hex Head Washer. The APA21 and APLH use SD10112DBB screws. The APHH uses SDWS22312DBB wood screws inserted through the STN22 Hex Head Washer and also the SDS25300 screws. The APL, APDJT, and APT ties are used to connect wood beams to wood columns. The APA is used as a heavy angle, while the APA21 is used as a light rafter tie. The APB is used to attach a wood post to a foundation. The APLH and APHH are hangers used to connect wood beams. The AP connectors are fabricated from No. 12 gage steel, except the APA21 and APLH, which are fabricated from 14 gage steel. [Table 9](#) and [Figure 9](#) of this report provide model numbers, fastener schedules, allowable loads, connector and component dimensions, and installation details.

3.1.10 LSSJR/L Field Adjustable Jack Hanger Series: The LSSJR/L are mirror-image hangers skewed at 45 degrees right and left, respectively. The LSSJR/L is used to connect a rafter to a hip or valley member. The LSSJR/L is field-adjusted with a one-time bend at the designated bend lines to accommodate variable jack skews. The LSSJR/L is field-adjusted by a rotatable seat to accommodate variable roof pitches. The LSSJR/L are formed from No. 18 gage galvanized steel. [Table 10](#) and [Figure 10](#) of this report provide fastener schedules, allowable loads, connector dimensions, and a typical installation detail.

3.1.11 MMHC Hinged Roof Connector: The MMHC is a hinged roof connector that attaches a roof rafter to a ceiling joist using 10d by 1½-inch nails. The MMHC allows for the roof to be constructed and transported flat and then reopened

on the jobsite to the appropriate roof pitch. The MMHC can also be used to attach a roof rafter to a kneewall stud. The MMHC is fabricated from 18 gage galvanized steel. [Table 11](#) and [Figure 11](#) of this report provide fastener schedules, allowable loads, connector and component dimensions, and installation details.

3.2 Materials

3.2.1 Steel: The connectors described in this report are manufactured from galvanized steel complying with [ASTM A653](#), SS designation, with a minimum yield strength, F_y , of 33,000 psi (227 MPa) and a minimum tensile strength, F_u , of 45,000 psi (310 MPa), except for the DS Drywall Stop connector, which is fabricated from galvanized steel complying with ASTM A653, FS designation, without specified minimum yield and tensile strengths. Base metal thicknesses for the connectors in this report are as follows:

GAGE	BASE METAL THICKNESS (in.)
No. 12	0.0975
No. 14	0.0685
No. 16	0.0555
No. 18	0.0455
No. 20	0.0335

For SI: 1 inch = 25.4 mm

The connectors have a minimum G90 zinc coating specification in accordance with ASTM A653. Some models may also be available with either a G185 zinc coating (denoted by model numbers ending in the letter Z) or with a batch hot-dipped galvanized coating with a minimum specified coating weight of 2.0 ounces of zinc per square foot of surface area (600 g/m²), total for both sides in accordance with [ASTM A123](#) (denoted by model numbers ending with the letters HDG). The AP Connectors are only fabricated with a G185 coating with a black color coating. With the exception of the RTC2Z and RTC22Z, which are only fabricated in ZMAX G185 coating, model numbers in this report do not list the Z or HDG ending, but the information shown applies.

The holder of this report (Simpson Strong-Tie Company Inc.) or lumber treater shall be contacted for recommendations on minimum corrosion resistance of steel connectors in contact with the specific proprietary preservative-treated or fire-retardant-treated lumber.

3.2.2 Wood: Wood members with which the connectors are used shall be either sawn lumber or engineered lumber having a minimum specific gravity of 0.50 (minimum equivalent specific gravity of 0.50 for engineered lumber), and having a maximum moisture content of 19 percent (16 percent for engineered lumber). Engineered lumber include glued laminated lumber (glulam) and parallel strand lumber



(PSL). Glulams shall comply with applicable AITC Standards referenced in IBC Section [2306](#). PSL shall be approved based on requirements in [ASTM D5456](#). The thickness (depth) of the wood main member shall be equal to or greater than the length of the fasteners specified in the tables in this report, unless the reduced penetration effect on the load calculation per the applicable ANSI/AWC National Design Specification for Wood Construction and its Supplement (NDS) is taken into account, or as required by wood member design, whichever is greater.

3.2.3 Fasteners: Common nails shall comply with [ASTM F1667](#) when used with connectors in this report and have the following minimum fastener dimensions and bending yield strengths (F_{yb}):

FASTENER	SHANK DIAMETER (inches)	FASTENER LENGTH (inches)	F_{yb} (psi)
8d x 1½	0.131	1½	100,000
8d	0.131	2½	100,000
10d x 1½	0.148	1½	90,000
10d	0.148	3	90,000
16d Sinker	0.148	3¼	90,000
16d	0.162	3½	90,000

For SI: 1 inch = 25.4 mm, 1 psi = 6.895 kPa.

Fasteners and washer used with the No.12 gage AP connectors described in Section 3.1.9 of this report shall be Simpson Strong-Tie SDWS22312DBB or SDWS22512DBB wood screws, inserted through the STN22 Hex Head Washer, recognized in IAPMO UES [ER-192](#). Fasteners used with the No. 14 gage APA21 shall be SD10112DBB.

Fasteners used in contact with fire-retardant-treated or preservative-treated lumber shall comply with Section 2304.10.5 of the 2015 IBC Section [2304.9.5](#) of the 2012 and 2009 IBC, or Section [R317.3](#) of the 2015, 2012 and 2009 IRC (2006 IRC Section [R319.3](#)), as applicable. The report holder or lumber treater shall be contacted for recommendations on minimum corrosion resistance and connection capacities of fasteners used with the specific proprietary preservative-treated or fire-retardant treated lumber.

The proprietary steel pins used with the CJTZ and HCJTZ connectors are manufactured from carbon steel conforming to [SAE J403](#) specifications, designations C12L14, C1215, C1015, C1018, or C1022. The bolts used with the DJT14 shall conform to [ASTM F1554](#) Grade 36 (minimum) or [A307](#).

SDS and SD wood screw fasteners shall be Simpson Strong-Tie wood screws recognized in ICC-ES [ESR-2236](#) and ICC-

ES [ESR-3046](#), respectively.

4.0 DESIGN AND INSTALLATION

4.1 Design: The tabulated connector loads shown in this report are for allowable stress design and include the load duration factor, C_D , corresponding with the applicable loads in accordance with the ANSI/AWC National Design Specification for Wood Construction and its supplement (NDS). Further load duration increases are not permitted other than those shown.

Tabulated allowable loads apply to products connected to wood used where sustained temperatures are 100°F (37.8°C) or less and under dry conditions. The allowable loads in this report shall be adjusted by the temperature factor, C_t , specified in the NDS when connectors are installed in wood that will experience sustained exposure to temperatures exceeding 100°F (37.8°C).

The allowable loads shall be adjusted by the wet service factor, C_M , specified in the NDS for dowel-type fasteners, when products are installed to wood having a moisture content greater than 19 percent (16 percent for engineered wood products), or where wet service is expected.

4.2 Installation: Installation of the connectors shown in this report shall be in accordance with the manufacturer's published installation instructions and this evaluation report. If there is a conflict between this report and the manufacturer's published installation instructions, the more restrictive shall govern.

5.0 LIMITATIONS

The Simpson Strong-Tie products described in this report are in compliance with, or are acceptable alternatives to what is specified in those codes listed in Section 1.0 of this report subject to the following conditions:

5.1 The connectors shall be manufactured, identified and installed in accordance with the manufacturer's published installation instructions and this report. A copy of the instructions shall be available at the jobsite continuously during installation.

5.2 Calculations and details showing compliance with this report shall be submitted to the code official. No further duration of load increase for earthquake or wind loading is allowed except where already shown in the load tables. The calculations and details shall be prepared by a registered design professional where required by the statutes of the jurisdiction in which the project is to be constructed.

5.3 Where applicable, adjustment factors noted in Section 4.1 of this report and the applicable codes shall be considered.



5.4 Fasteners and connected wood members shall be in compliance, respectively, with Sections 3.2.2 and 3.2.3 of this report.

5.5 Use of connectors with fire-retardant-treated or preservative-treated lumber shall be in accordance with Section 3.2.1 of this report. Use of fasteners with fire-retardant-treated or preservative-treated lumber shall be in accordance with Section 3.2.3 of this report.

6.0 SUBSTANTIATING DATA

6.1 Data in accordance with IAPMO UES Evaluation Criteria for the Testing and Analysis of Joist Hangers and Miscellaneous Connectors (EC 002-2017), inclusive of tests and calculations.

6.2 Data in accordance with Section 3.4 of ICC-ES Acceptance Criteria for Joist Hangers and Similar Devices (AC13), dated February 2017.

7.0 IDENTIFICATION

The products described in this report are identified with a die-stamped label indicating the name of the manufacturer (Simpson Strong-Tie), the model number, and the number of the index evaluation report ([ER-102](#)), which identifies products recognized in this report. The SD9, SD10 and SDS wood screws are identified as described in evaluation reports ICC-ES [ESR-3046](#) and ICC-ES [ESR-2236](#), respectively.

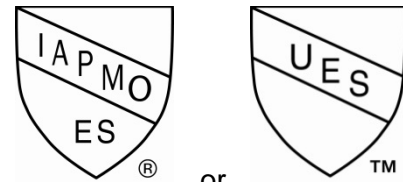

IAPMO UES ER-280

Brian Gerber

Brian Gerber, P.E., S.E.
Vice President, Technical Operations
Uniform Evaluation Service

Richard Beck

Richard Beck, PE, CBO, MCP
Vice President, Uniform Evaluation Service

Russ Chaney
GP Russ Chaney

CEO, The IAPMO Group

For additional information about this evaluation report please visit www.uniform-es.org or email at info@uniform-es

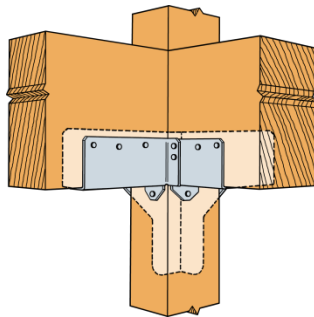

TABLE 1—ALLOWABLE LOADS FOR THE RTC SERIES RIGID TIE CONNECTORS

MODEL NO.	NOMINAL POST SIZE ³	NOMINAL JOIST SIZE ³	FASTENERS ^{4,5} (Quantity-Type)		ALLOWABLE DOWNLOAD ^{1,2} (lbf)	
			Post	Joist (Total)	C _D =1.00	C _D =1.25
RTC22Z	2" x 4"	2x	5 – SD9 x 1 ½"	6 – SD9 x 1 ½"	775	775
RTC42	4" x 4"	2x	14 – SD10 x 1 ½"	14 – SD10 x 1 ½"	2,420	3,030
RTC44	4" x 4"	4x	14 – SD10 x 1 ½"	15 – SD10 x 1 ½"	2,420	3,030
RTC2Z	2" x 4"	2x	5 – SD9 x 1 ½"	5 – SD9 x 1 ½"	1,025	1,260

For SI: 1 inch = 25.4 mm, 1 lbf = 4.45 N.

1. Tabulated allowable load capacities shall be selected based on duration of load, C_D, as permitted by the applicable building code.
2. Allowable loads shall be equally distributed to both joists.
3. Loads are for Douglas Fir Larch lumber only.
4. NAILS: 16d = 0.162 inch dia. x 3 ½ inches long, 16d Sinker = 0.148 inch dia. x 3 ¼ inches long, 10dx1 ½ = 0.148 inch dia. x 1 ½ inches long.
5. SCREWS: SD9x1.5 = 0.131 inch dia. x 1 ½ inches long have the model designation SD#9x1 ½ or SD9112. SD10x1.5 = 0.161 inch dia. x 1 ½ inches long have the model designation SD#10x1 ½ or SD10112. ICC-ES [ESR-3046](#) has more details.



RTC42
(RTC22Z, RTC2Z and RTC44 models similar)

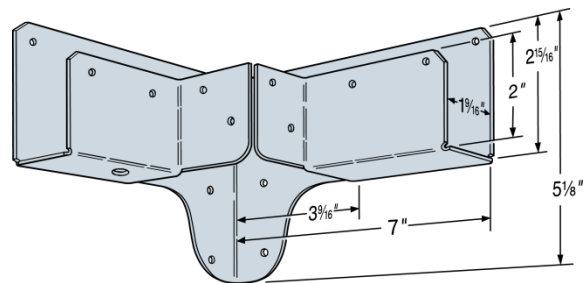

Post
Typical RTC Installation

FIGURE 1—RTC RIGID TIE CONNECTORS

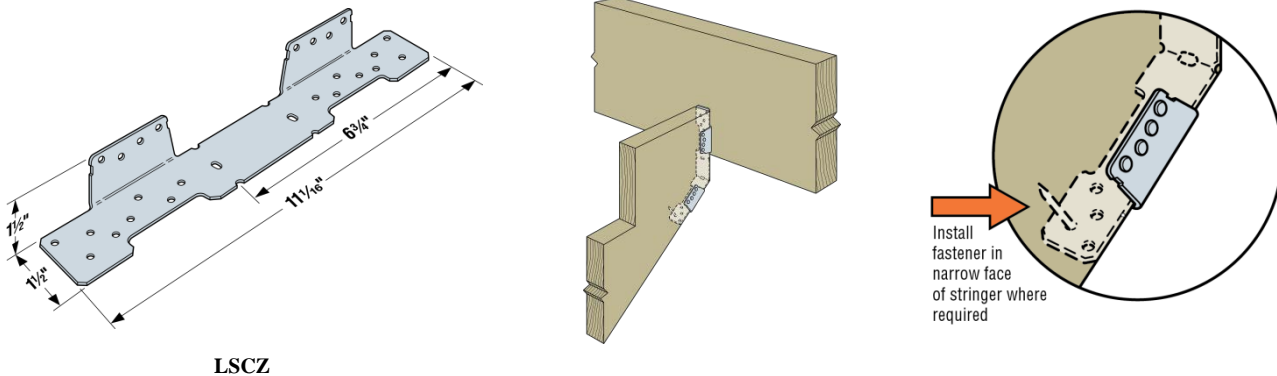

TABLE 2—ALLOWABLE LOADS FOR THE LSCZ ADJUSTABLE STRINGER CONNECTOR⁵

MODEL NO.	RIM JOIST INSTALLATION	FASTENER SCHEDULE ⁴ (Quantity – Type)			ALLOWABLE LOADS (lbf) ^{3,6}	
		Rim Joist (in)	Stringer Wide Face (in)	Stringer Narrow Face (in)	C _D = 1.0	C _D = 1.15
LSCZ	Supported ¹	8 – 10d x 1 1/2	8 – 10d x 1 1/2	1 – 10d x 1 1/2	945	960
	Cantilever ²	8 – 10d x 1 1/2	8 – 10d x 1 1/2	1 – 10d x 1 1/2	460	460

For SI: 1 inch = 25.4 mm, 1 lbf = 4.45 N.

- Supported installations require rim joist bearing support within 12 inches of LSCZ.
- A maximum rim joist cantilever length of 12 inches measured from face of bearing support to end of rim joist is permitted for cantilever installation.
- When cross-grain tension forces cannot be avoided in the members, mechanical reinforcement to resist such forces shall be considered.
- A minimum distance of 3/4 inch measured from the lowest rim joist fastener to edge of rim joist is required.
- A minimum distance of 3 1/2 inches measured from the LSCZ adjustable stringer connector tabs to the end of the rim joist is required.
- The LSCZ has not been evaluated for torsional resistance.



LSCZ

Typical LSCZ Installation

FIGURE 2—LSCZ ADJUSTABLE STRINGER CONNECTOR

TABLE 3—ALLOWABLE LOADS FOR THE DJT DECK JOIST TIE CONNECTOR

MODEL NO.	FASTENERS (Quantity–Type)		ALLOWABLE DOWNLOAD ^{1,2} (lbf)					
			Nails			Bolts		
	Common Nails	Bolts ³	C _D =1.00	C _D =1.15	C _D =1.25	C _D =1.00	C _D =1.15	C _D =1.25
DJT14	8 – 16d	2 – 3/8" Ø MB	1,160	1,320	1,325	1,325		

For SI: 1 inch = 25.4 mm, 1 lbf = 4.45 N.

- Tabulated allowable load capacities shall be selected based on duration of load, C_D, as permitted by the applicable building code.
- Loads are for one connector installed with nails or bolts, but not both. Allowable loads given for installations with nails and bolts are not cumulative.
- Machine bolts (MB) shall comply with [ANSI/ASME Standard B18.2.1](#) and either [ASTM A36](#) or [A307](#).

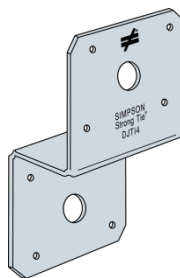

DJT14

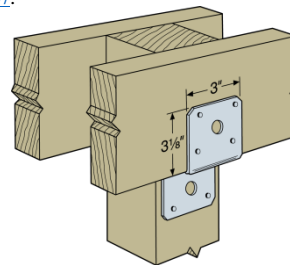

Typical DJT14 Installation

FIGURE 3—DJT DECK JOIST TIE CONNECTOR

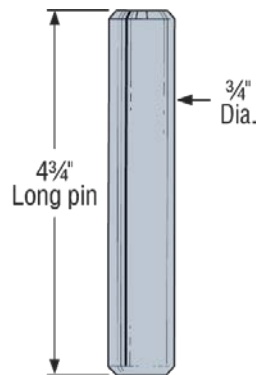
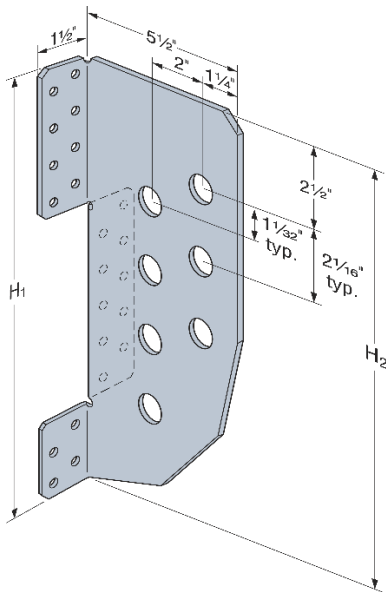
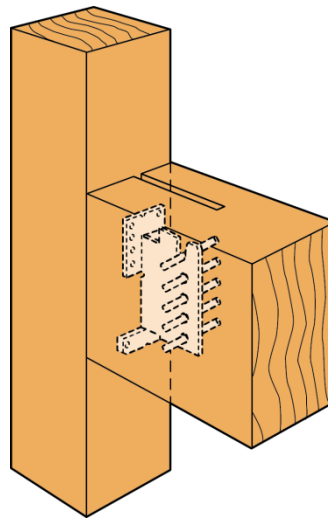
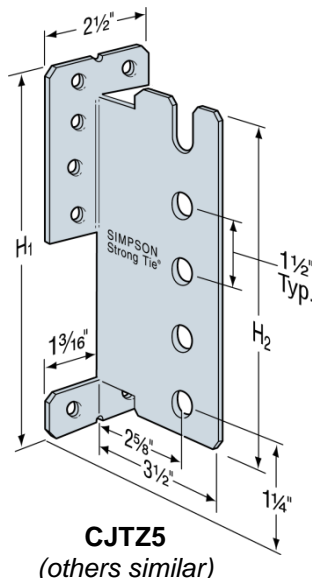

TABLE 4—ALLOWABLE LOADS FOR THE CJTZ AND HCJTZ CONCEALED JOIST TIE CONNECTORS

MODEL NO.	MIN. JOIST SIZE	DIMENSIONS		FASTENERS (Quantity–Type)		ALLOWABLE LOADS ¹ (lbf)			
		H ₁	H ₂	Post ² (SDS)	Joist ³ (Pins)	UPLIFT ⁴	DOWNLOAD		
						C _D =1.60	C _D =1.00	C _D =1.15	C _D =1.25
DOUGLAS FIR–LARCH									
CJT3Z	4 × 8	5 9/16"	4 7/16"	6 – SDS 1/4 × 3"	3 – 1/2" × 2 3/4"	1,540	1,730	1,730	1,730
					3 – 1/2" × 4 3/4"	1,540	1,730	1,730	1,730
CJT4Z	4 × 10	7	5 15/16"	8 – SDS 1/4 × 3"	4 – 1/2" × 2 3/4"	2,625	2,970	2,970	2,970
					4 – 1/2" × 4 3/4"	2,625	2,970	2,970	2,970
CJT5Z	4 × 12	8 9/16"	7 7/16"	10 – SDS 1/4 × 3"	5 – 1/2" × 2 3/4"	3,160	3,935	4,520	4,580
					5 – 1/2" × 4 3/4"	3,160	4,200	4,580	4,580
CJT6Z	4 × 12	10	8 15/16"	12 – SDS 1/4 × 3"	6 – 1/2" × 2 3/4"	4,305	4,220	4,220	4,220
					6 – 1/2" × 4 3/4"	4,305	4,220	4,220	4,220
HCJTZ	6 × 16	13 1/16"	13 1/16"	22 – SDS 1/4 × 3"	7 – 3/4" × 4 3/4"	9,210	8,465	8,465	8,465
GLULAM⁵									
CJT3Z	3 1/8 × 7 1/2	5 9/16"	4 7/16"	6 – SDS 1/4 × 3"	3 – 1/2" × 2 3/4"	1,540	1,835	1,835	1,835
					3 – 1/2" × 4 3/4"	1,540	1,835	1,835	1,835
CJT4Z	3 1/8 × 9	7"	5 15/16"	8 – SDS 1/4 × 3"	4 – 1/2" × 2 3/4"	2,625	3,180	3,180	3,180
					4 – 1/2" × 4 3/4"	2,625	3,180	3,180	3,180
CJT5Z	3 1/8 × 10 1/2	8 9/16"	7 7/16"	10 – SDS 1/4 × 3"	5 – 1/2" × 2 3/4"	3,160	3,900	4,480	4,570
					5 – 1/2" × 4 3/4"	3,160	4,200	4,570	4,570
CJT6Z	3 1/8 × 12	10"	8 15/16"	12 – SDS 1/4 × 3"	6 – 1/2" × 2 3/4"	4,305	4,510	4,860	4,860
					6 – 1/2" × 4 3/4"	4,305	4,860	4,860	4,860
HCJTZ	5 1/8 × 15	13 1/16"	13 1/16"	22 – SDS 1/4 × 3"	7 – 3/4" × 4 3/4"	9,210	8,465	8,465	8,465
PSL⁵									
CJT3Z	3 1/2 × 9 1/2	5 9/16"	4 7/16"	6 – SDS 1/4 × 3"	3 – 1/2" × 2 3/4"	1,540	2,220	2,220	2,220
					3 – 1/2" × 4 3/4"	1,540	2,220	2,220	2,220
CJT4Z	3 1/2 × 9 1/2	7"	5 15/16"	8 – SDS 1/4 × 3"	4 – 1/2" × 2 3/4"	2,625	2,810	2,810	2,810
					4 – 1/2" × 4 3/4"	2,625	2,810	2,810	2,810
CJT5Z	3 1/2 × 9 1/2	8 9/16"	7 7/16"	10 – SDS 1/4 × 3"	5 – 1/2" × 2 3/4"	3,160	3,980	4,285	4,285
					5 – 1/2" × 4 3/4"	3,160	4,200	4,285	4,285
CJT6Z	3 1/2 × 11 7/8	10"	8 15/16"	12 – SDS 1/4 × 3"	6 – 1/2" × 2 3/4"	4,305	4,640	4,640	4,640
					6 – 1/2" × 4 3/4"	4,305	4,640	4,640	4,640
HCJTZ	5 1/8 × 15	13 1/16"	13 1/16"	22 – SDS 1/4 × 3"	7 – 3/4" × 4 3/4"	9,210	8,465	8,465	8,465

For **SI**: 1 inch = 25.4 mm, 1 lbf = 4.45 N.

1. Tabulated allowable load capacities shall be selected based on duration of load, C_D, as permitted by the applicable building code.
2. SDS wood screws have the model designation SDS 1/4 x 3 or SDS25300. Additional details are in evaluation report ICC-ES ESR-2236.
3. The quantity and length of the pins are specified in the Table. The Pins are supplied by Simpson Strong-Tie Company as a component of the CJT series hanger.
4. The uplift loads have been increased for wind or earthquake loading (C_D = 1.60) with no further increase allowed. The allowable load shall be reduced when other load durations govern.
5. Glulam is glued-laminated timber. PSL is Parallel Strand Lumber. Additional details are described in Section 3.2.2 of this report.



HCJTZ

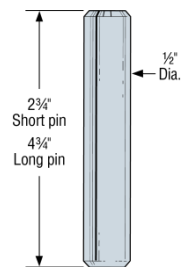
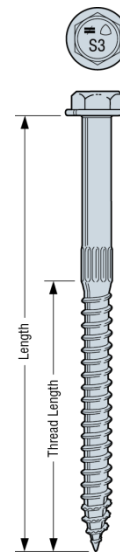

Chamfered Steel Pins

SDS 1/4 x 3"
 U.S. Patent 6,109,850;
 5,897,280; 7,101,133;
 7,832,173

FIGURE 4—CJTZ AND HCJTZ CONCEALED JOIST TIE CONNECTOR COMPONENTS



TABLE 5—DS DRYWALL STOP^{1,2}

MODEL NO.	FASTENERS (Quantity–Type)		MAXIMUM O.C. SPACING (in)
	Wood Framing	Steel Stud Framing ³	
DS	1–8d Common Nail	1–No. 6 Self–drilling Tapping Screw ⁴	16

For SI: 1 inch = 25.4 mm, 1 lbf = 4.45 N.

1. Use of the DS Drywall Stops is limited to nonfire–resistance–rated construction and to nonstructural applications.
2. Use of the DS drywall stops may not replace the required gypsum fasteners specified in the 2015 IRC Section R702.3.5.1 or 2012 IRC Section [R702.3.6](#) in designated braced wall panels conforming to Section [R602.10.1](#) of the 2015 and 2012 IRC, Section [R602.10.1.1](#) of the 2009 IRC or [R602.10.3](#) of the 2006 IRC.
3. Steel studs shall have a minimum thickness of 30 mils (0.0296–inch base metal thickness).
4. Self–drilling tapping screws shall comply with [ASTM C1513](#) and [SAE J78](#), and when required by code, shall have a Type II coating in accordance with [ASTM B633](#).

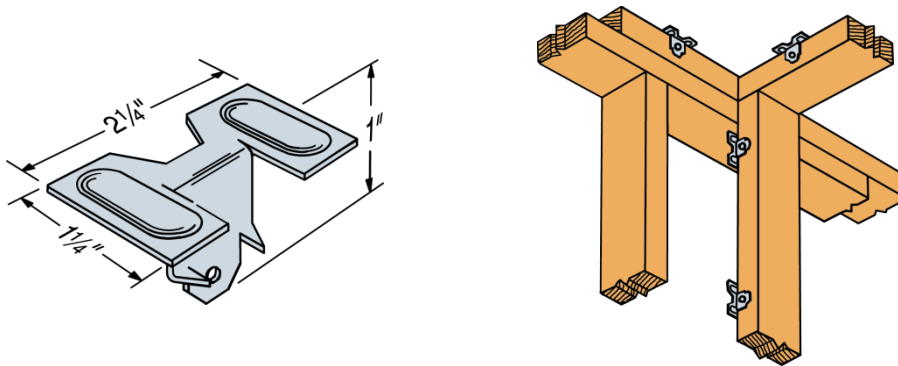

FIGURE 5—DS DRYWALL STOP

TABLE 6—HTC4 TRUSS CONNECTOR

MODEL NO.	DIMENSIONS	FASTENERS		ALLOWABLE LOADS ¹ (lbf) (C _D =1.60)				
		Top Plate	Base	Slot	Without Gap ²		With 1 ¹ / ₄ " Gap ³	
					F ₁	F ₂	F ₁	F ₂
HTC4	2X4 Plate	6-10d	3-10d	370	310	85	255	
	2X6 Plate	6-10d	3-10d	410	265	155	250	

For SI: 1 inch = 25.4 mm, 1 lbf = 4.45 N.

1. Allowable Loads shall not be increased for short term loading
2. Truss or rafter shall be bearing on top plate to achieve the allowable loads under "WITHOUT GAP"
3. When installed with the maximum 1¹/₄ inch space between rafter or truss and top plate, allowable loads under "WITH 1¹/₄" GAP" are permitted. Where loads not required the space is not limited to 1¹/₄ inch maximum
4. Nails: 10d = 0.148 inch diameter X 3 inches long.

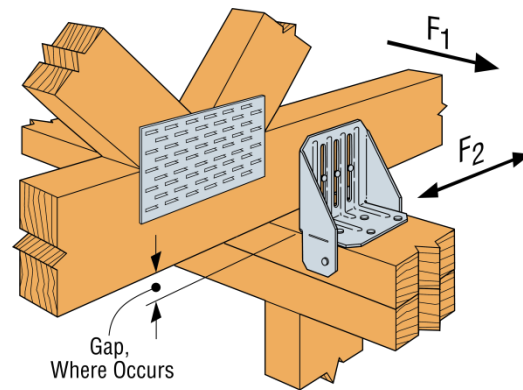
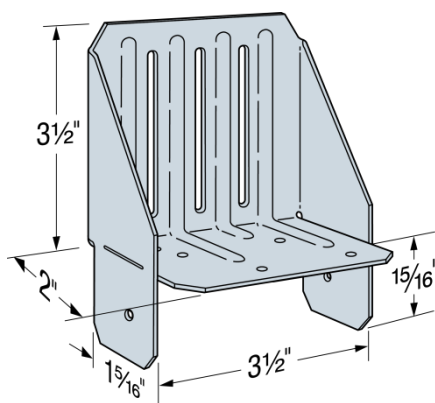

Allow 1/16" gap between nailhead and truss clip to help prevent squeaking

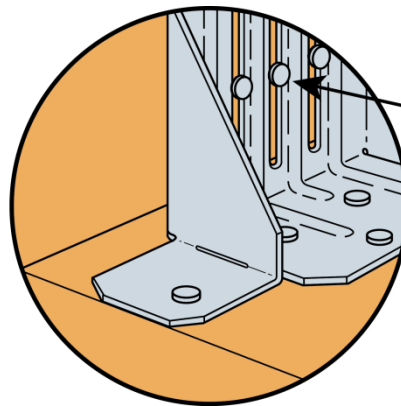

Nails should not be driven completely flush against the connector, to allow vertical truss movement.

Typical HTC4 Installation on a 2x6 or Larger Plate

FIGURE 6—HTC4 TRUSS CONNECTOR

TABLE 7 – ALLOWABLE LOADS FOR THE KBS1Z KNEE-BRACE STABILIZER

MODEL NO.	DIMENSIONS		TYPE OF CONNECTION	CONNECTORS PER JOINT	FASTENERS EACH CONNECTOR	DIRECTION OF LOAD ³	ALLOWABLE LOADS ² (lbf) (C _D =1.60)
	W	L					
KBS1Z	1½"	3"	1	2	12 - 8d	F1 Brace angle = 45°	1,175
						F1 Brace angle = 30° or 60°	835
			2	1	12 - 8d x 1½"	F1 Brace angle = 45°	630
						F1 Brace angle = 30° or 60°	510
			3	4	12 - 8d	Uplift	1,160
						Lateral	1,725
			4	2	12 - 8d	Uplift	540
						Lateral	485
						Uplift	900
				4		Lateral	1,270

For SI: 1 inch = 25.4 mm, 1 lbf = 4.45 N.

- SD9x1½ screws may be substituted for the specified fasteners with no load reduction. SD9x1½ = 0.131 inch dia x 1½ inches long have the model designation SD#9x1½ or SD9112. ICC-ES [ESR-3046](#) has more details.
- Allowable loads have been increased for wind or earthquake loading (C_D = 1.60) with no further increases allowed. Reduce allowable load when other load durations govern.
- For braces installed at intermediate angles, allowable loads may be interpolated between loads listed for brace angle = 45° and brace angle = 30° or 60°.

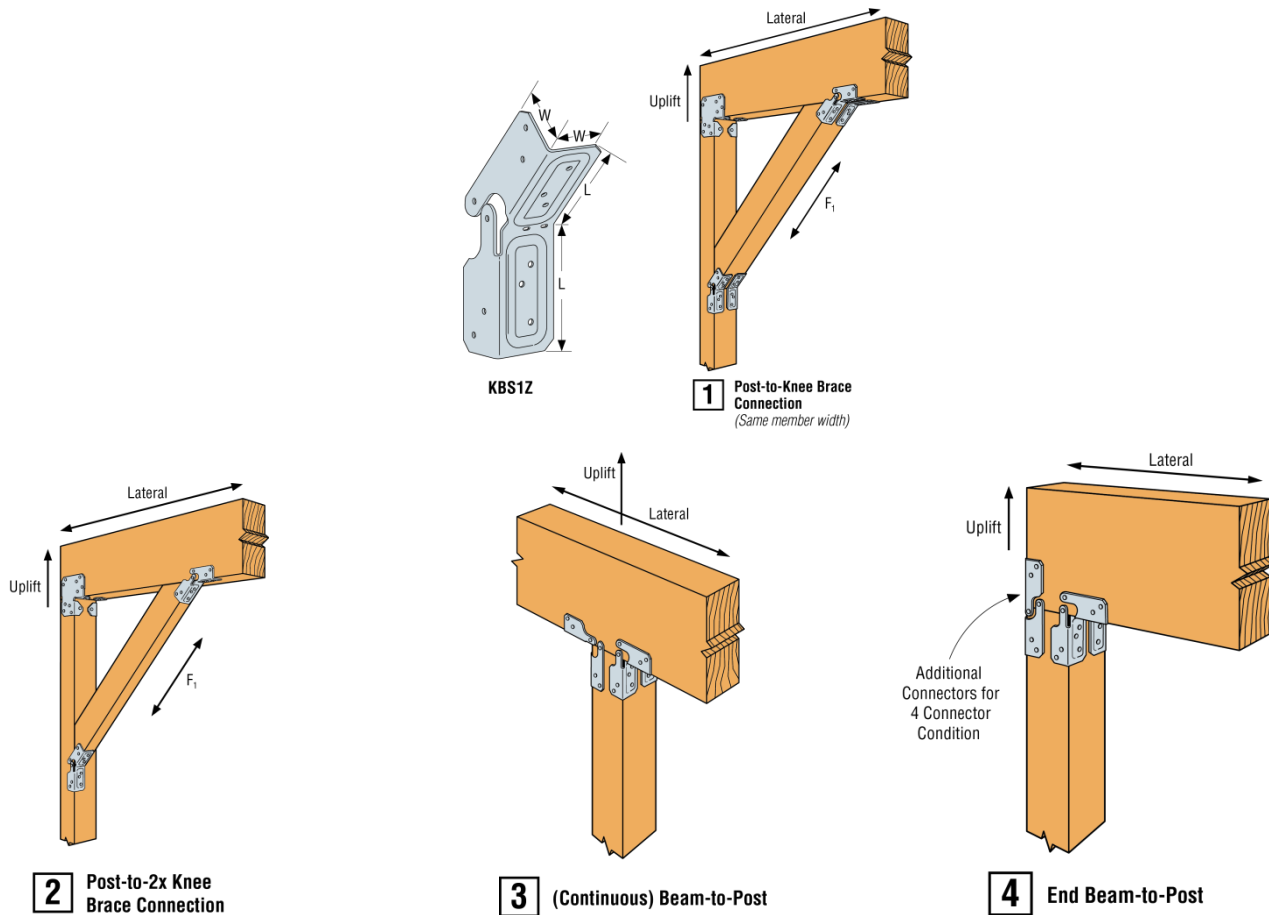

FIGURE 7 – KBS1Z KNEE-BRACE STABILIZER



TABLE 8—ALLOWABLE LOADS FOR THE CBTZ CONCEALED BEAM TIE CONNECTOR

MODEL NO.	POST (Min.)	BEAM (Min.)	DIMENSIONS		FASTENERS			ALLOWABLE LOADS ¹ (lbf)					
			Dia. (in)	H (in)	Quantity		Type ^{4,5}	Continuous Beam			End of Beam		
					Post	Beam		Down ³	Uplift	Lateral ²	Uplift	Lateral ²	Down ³
									C _D =1.60	C _D =1.60		C _D =1.60	
CBT2Z	4x4	4x6	1 1/4	10	2	2	1/2" x 3 1/4" dowel 1/2" MB	2,020	750	6,890	1,585	550	6,890
CBT4Z	6x6	6x8	1 1/4	14	3	3	1/2" x 4 3/4" dowel 1/2" MB	4,215	1,655	18,140	3,695	1,055	18,140

For SI: 1 inch = 25.4 mm, 1 lbf = 4.45 N.

1. Allowable uplift and lateral loads have been increased for wind or earthquake with no further increase allowed; reduce where other loads govern.
2. Lateral load is in the direction parallel to the beam.
3. Downloads are based on a wood bearing area calculation, $F_{c,perp} = 625$ psi.
4. 1/2" diameter dowel pins are supplied with the CBTZ series connectors. Alternate 1/2" diameter hex or square head machine bolts may be used for loads listed.
5. Lag or carriage bolts are not permitted.
6. Structural composite lumber columns have sides that show either the wide face or the edges of the lumber strands/veneers. Values in the tables reflect dowel or bolt installation into the wide face.
7. Spliced condition shall be detailed by Designer.

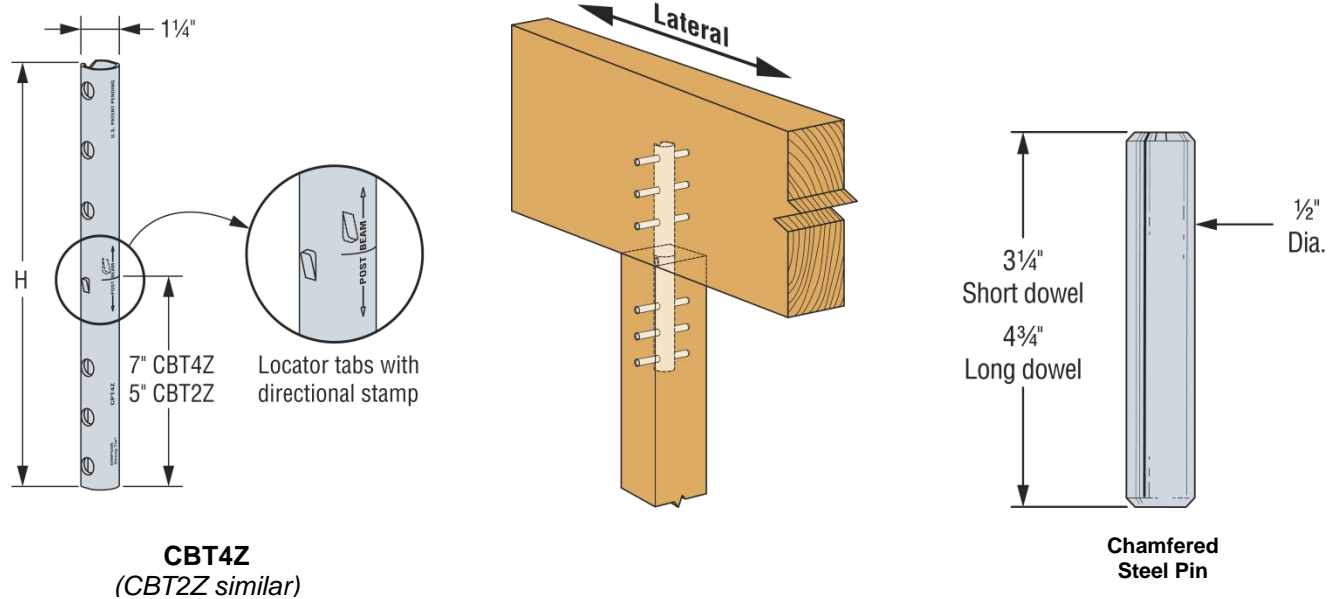

FIGURE 8—CBTZ CONCEALED BEAM TIE CONNECTOR COMPONENTS



TABLE 9A— APL and APT BEAM-TO-COLUMN TIES^{1,2,3}

MODEL NO.	Ga	DIMENSIONS			FASTENER QTY.		ALLOWABLE LOADS (lbf)	
		W (in)	L (in)	H (in)	Column	Beam	Uplift	F1
APL4	12	3	8 ¼	8 ¼	2	4	1,155	670
APL6	12	5	11¼	11 ¼	4	6	1,905	1,340
APT4	12	3	13 ½	8 ¼	2	4	1,330	1,015
APT6	12	5	17 ½	11 ¼	4	8	2,130	1,425

For **SI**: 1 inch = 25.4 mm, 1 lbf = 4.45 N.

1. Allowable loads have been increased for wind or seismic loads with no further increase allowed.
2. Connectors shall be installed in pairs. Allowable loads do not apply to single parts.
3. All fasteners are a Simpson SDWS22312DBB inserted through STN22.

TABLE 9B— APA HEAVY ANGLES^{1,2,3}

MODEL NO.	Ga	DIMENSIONS			FASTENER QTY.		ALLOWABLE LOADS (lbf)	
		L (in)	W1 (in)	W2 (in)	Column	Beam	Uplift	F1
APA4	12	3	3 ¼	3	2	2	710	1,220
APA6	12	5	3 ¾	3 ½	4	4	1,350	1,985

For **SI**: 1 inch = 25.4 mm, 1 lbf = 4.45 N.

1. Allowable loads have been increased for wind or seismic loads with no further increase allowed.
2. Connectors shall be installed in pairs. Allowable loads do not apply to single parts.
3. All fasteners are a Simpson SDWS22312DBB inserted through STN22.

TABLE 9C— APA21 LIGHT RAFTER TIE^{1,2,3}

MODEL NO.	Ga	DIMENSIONS			FASTENER QTY.		ALLOWABLE LOADS (lbf)	
		L (in)	W1 (in)	W2 (in)	Rafter	Beam	Uplift	F1
APA21	14	1 ¾	2	1 ½	1	1	200	120

For **SI**: 1 inch = 25.4 mm, 1 lbf = 4.45 N.

1. Allowable loads have been increased for wind or seismic loads with no further increase allowed.
2. Allowable loads are for a single part.
3. All fasteners are Simpson SD10112DBB

TABLE 9D— APB POST BASES^{1,2,3,4,5,6}

MODEL NO.	Ga	DIMENSIONS			FASTENER QTY.		ALLOWABLE LOADS (lbf)	
		L (in)	W (in)	H(in)	Post Qty.	Anchor Dia.	Uplift	Down
APB44	12	3	3 9/16	7	4	5/8	1,035	6,725
APB44R	12	3	4 1/16	6 ¾	4	5/8	1,035	6,725
APB66	12	5	5 ½	7 ½	4	5/8	1,260	11,450
APB66R	12	5	6	7 ¼	4	5/8	1,260	11,450
APB88	12	7	7 ½	10 9/16	8	2 5/8	2,670	22,255
APB88R	12	7	8	10 5/16	8	2 5/8	2,670	22,255
APB1010	12	9	9 ½	11	8	(2) 5/8	2,365	23,725
APB1010R	12	9	10	10 ¾	8	(2) 5/8	2,365	23,725

For **SI**: 1 inch = 25.4 mm, 1 lbf = 4.45 N.

1. Uplift loads have been increased for wind or seismic with no further increase allowed; reduce where others govern.
2. Downloads may not be increased for short-term loading.
3. Specifier to design concrete for uplift capacity.
4. Downloads shall be reduced where limited by capacity of the post.
5. Post fasteners are a Simpson SDWS22312DBB inserted through an STN22 nut.
6. Post bases do not provide adequate resistance to prevent members from rotating about the base and therefore are not recommended for non top-supported installations (such as fences or unbraced carports).



TABLE 9E— APDJT DECK JOIST TIE^{1,2,3}

MODEL NO.	Ga	DIMENSIONS			FASTENERS (Qty. and Length)		ALLOWABLE LOADS (lbs)	
		S (in)	W (in)	H(in)	Column	Joist	Floor (100)	Roof (125)
APDJT2-4	12	1 ½	3	10	(2) 3 ½"	(2) 5 ½"	1870	2340
APDJT2R-4	12	2	3	9 1/2	(2) 3 ½"	(2) 5 ½"	1870	2340
APDJT2-6	12	1 ½	5	10	(2) 3 ½"	(2) 5 ½"	1870	2340
APDJT2R-6	12	2	5	9 1/2	(2) 3 ½"	(2) 5 ½"	1870	2340

1. Roof loads are 125% of floor loads. Floor loads may be adjusted for other load durations according to the code, provided they do not exceed the roof loads.
2. Loads are per part.
3. Joist fastener is a Simpson Strong-Tie SDWS22512DBB inserted through an STN22 hex-head washer. Post fastener is a Simpson Strong-Tie SDWS22312DBB inserted through an STN22 hex-head washer.

TABLE 9F— APLH LIGHT HANGER

JOIST SIZE	MODEL NO.	Ga.	DIMENSIONS (in.)			FASTENERS (SD10112DBB)		ALLOWABLE LOADS (lbf)			
			W	H	B	Header Qty.	Joist Qty.	Uplift (160)	Floor (100)	Snow (115)	Roof (125)
2 × 4	APLH24	14	1 ⅞	3 ⅞	1 ⅞	4	2	315	690	795	865
	APLH24R		2 ⅞	3 ⅞							
2 × 6 or 2 × 8	APLH26	14	1 ⅞	5 ⅞	1 ⅞	6	4	900	1040	1195	1300
	APLH26R		2 ⅞	4 ⅞							
2 × 10 or 2 × 12	APLH210	14	1 ⅞	8	1 ⅞	10	6	1345	1730	1990	2165
	APLH210R		2 ⅞	7 ¾							

For SI: 1 inch = 25.4 mm, 1 lbf = 4.45 N.

1. Allowable uplift loads have been increased 60% for wind or wind or earthquake loading with no further increase allowed: reduce where other loads govern.
2. All fasteners are Simpson Strong-Tie SD10112DBB.

TABLE 9G— APHH HEAVY HANGER

JOIST SIZE	MODEL NO.	Ga.	DIMENSIONS (in.)			FASTENERS		DF/SP ALLOWABLE LOADS (lbf)			
			W	H	B	SDS25300 Header Qty.	SDWS22312 w/STN22 Joist Qty.	Uplift (160)	Floor (100)	Snow (115)	Roof (125)
4 × 6 or 4 × 8	APHH46	12	3 ⅞	5 ⅞	3	6	2	1165	2280	2280	2280
	APHH46R		4 ⅞	4 ⅞							
6 × 10 or 6 × 12	APHH610	12	5 ½	8 ½	3	14	6	4140	5880	6760	7350
	APHH610R		6	8 ¼							

For SI: 1 inch = 25.4 mm, 1 lbf = 4.45 N.

1. Allowable uplift loads have been increased 60% for wind or wind or earthquake loading with no further increase allowed: reduce where other loads govern.
2. All fasteners are Simpson Strong-Tie SDS25300 to the header and SDWS22312 with STN22 to the joist.

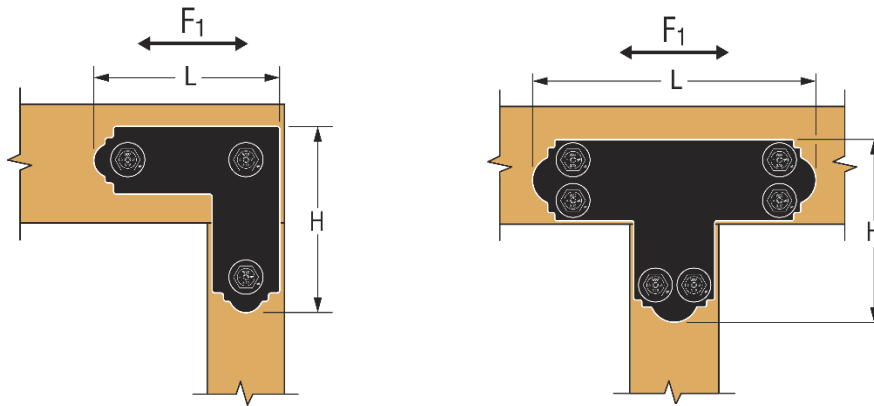

FIGURE 9A — APL AND APT DECORATIVE BEAM-TO-COLUMN TIES

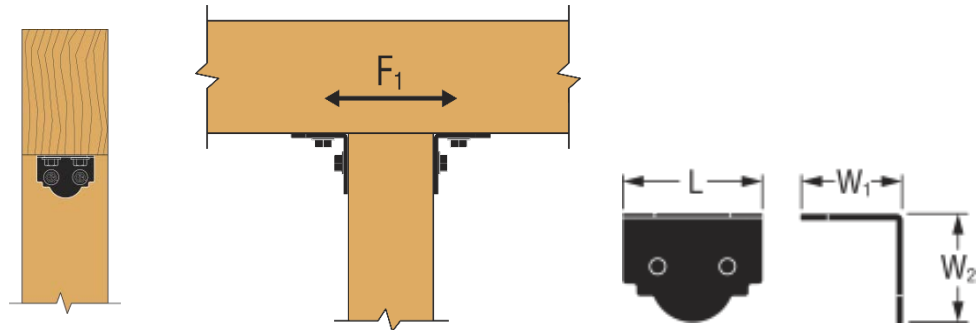

FIGURE 9B — APA DECORATIVE HEAVY ANGLES

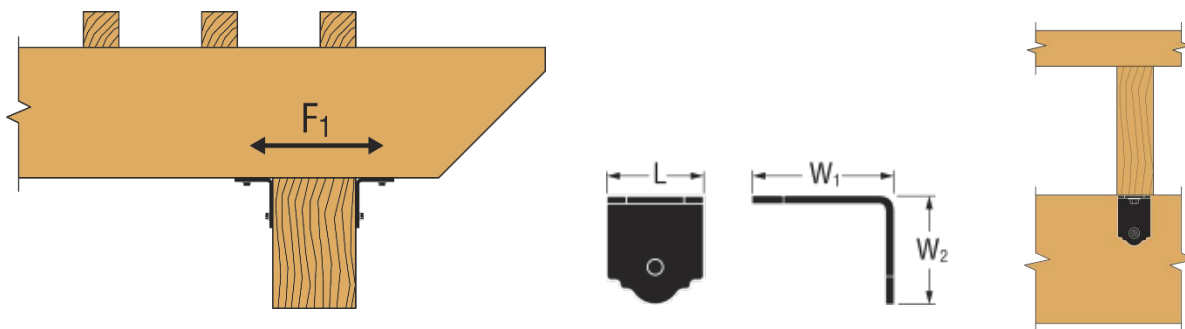

FIGURE 9C — APA21 DECORATIVE LIGHT RAFTER TIE

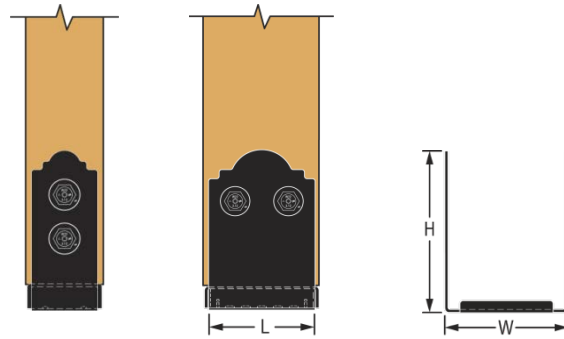
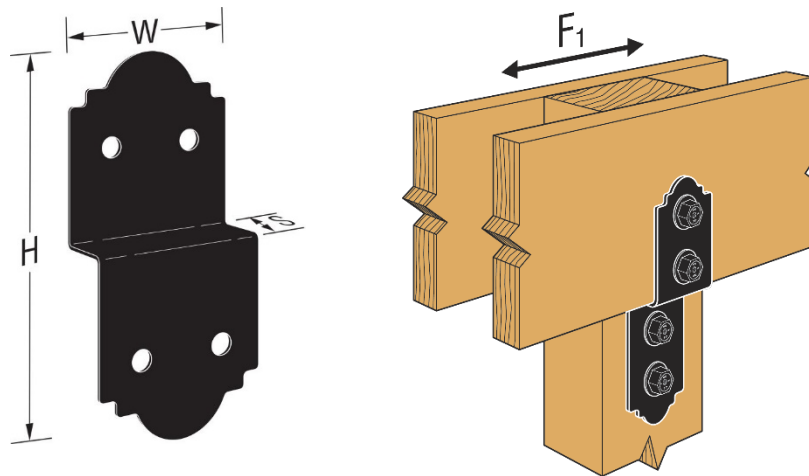
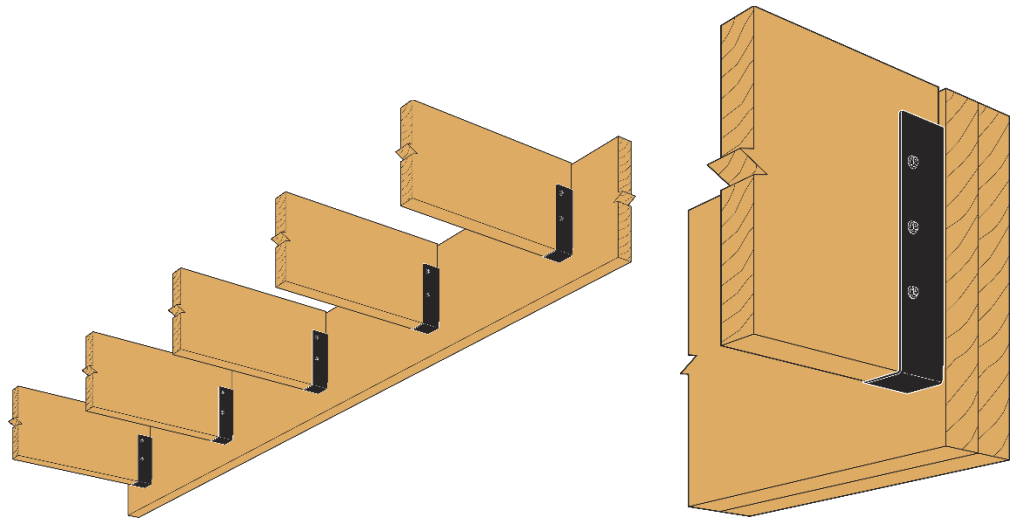
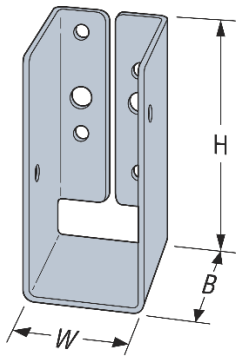

FIGURE 9D — APB DECORATIVE POST BASES



Typical APDJT2-6 Installation

FIGURE 9E — APDJT DECK JOIST TIE



APLH24

(Other sizes similar)

FIGURE 9F — APLH LIGHT HANGER

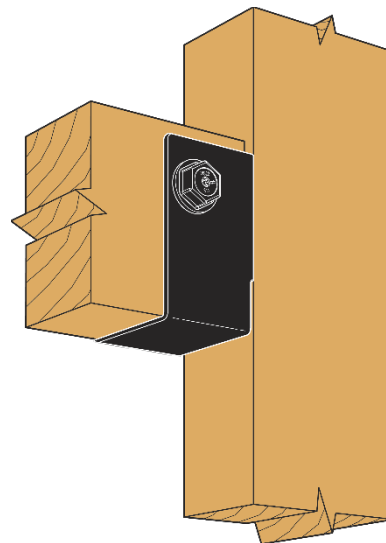
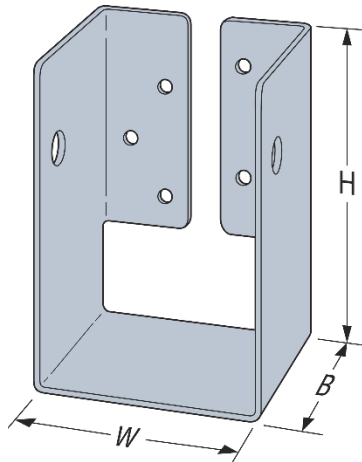

APHH46

(Other sizes similar)

FIGURE 9G — APHH HEAVY HANGER

TABLE 10—ALLOWABLE LOADS FOR THE LSSJ FIELD ADJUSTABLE JACK HANGER

MODEL NO.	DIMENSIONS ¹		FASTENERS ⁷ (Quantity-Type)		ALLOWABLE LOADS ^{2,4} (lbs)			
					UPLIFT ³	DOWNLOAD		
	W	H	Face	Joist ⁵	C _D =1.60	C _D =1.00	C _D =1.15	C _D =1.25
0□ - 20□ Skew								
LSSJ26LZ LSSJ26RZ	1 9/16	4 3/8	4-10d	4-10d	295	365	365	365
			4-10dx1½	4-10dx1½				
LSSJ28LZ LSSJ28RZ	1 9/16	6	5-10d	5-10d	450	590	605	605
			5-10dx1½	5-10dx1½				
LSSJ210LZ LSSJ210RZ	1 9/16	8	6-10d	6-10d	795	710	810	815
			6-10dx1½	6-10dx1½				
21□ - 45□ Skew								
LSSJ26LZ LSSJ26RZ	1 9/16	4 3/8	4-10d	4-10d	750	750	750	750
			4-10dx1½	4-10dx1½	295	420	420	420
LSSJ28LZ LSSJ28RZ	1 9/16	6	5-10d	5-10d	1165	1080	1165	1165
			5-10dx1½	5-10dx1½	450	590	675	725
LSSJ210LZ LSSJ210RZ	1 9/16	8	6-10d	6-10d	1420	1295	1445	1445
			6-10dx1½	6-10dx1½	795	710	810	815

For SI: 1 inch = 25.4 mm, 1 lbs = 4.45N

- Refer to Figure 10 of this report for definitions of hanger nomenclature (W, H).
- Tabulated allowable load capacities shall be selected based on duration of load, C_D, as permitted by the applicable building code.
- The uplift loads have been increased for wind or earthquake loading (C_D = 1.60) with no further increases allowed. Reduced allowable load when other load durations govern.
- Tabulated Loads apply to slope range +45 degrees to -45 degrees.
- Joist nails must be driven at a 45 degree angle through the joist into the header/hip (double shear nailing) to achieve the tabulated loads for 10d nails at skews 21-45 degrees.
- LSSJR/L Series hangers provide torsional resistance, which is defined as a moment of not less than 75 pounds (334 N) times the depth of the joist at which the lateral movement of the top or bottom of the joist with respect to the vertical position of the joist is 0.125 inch (3.2 mm) to comply with Section 3.4 of AC13. The height, H, of the joist hanger must be at least 60 percent of the height of the joist unless additional lateral restraint is provided, and designed by others.
- Refer to Section 3.2.3 of this report for nail sizes and required minimum physical properties.

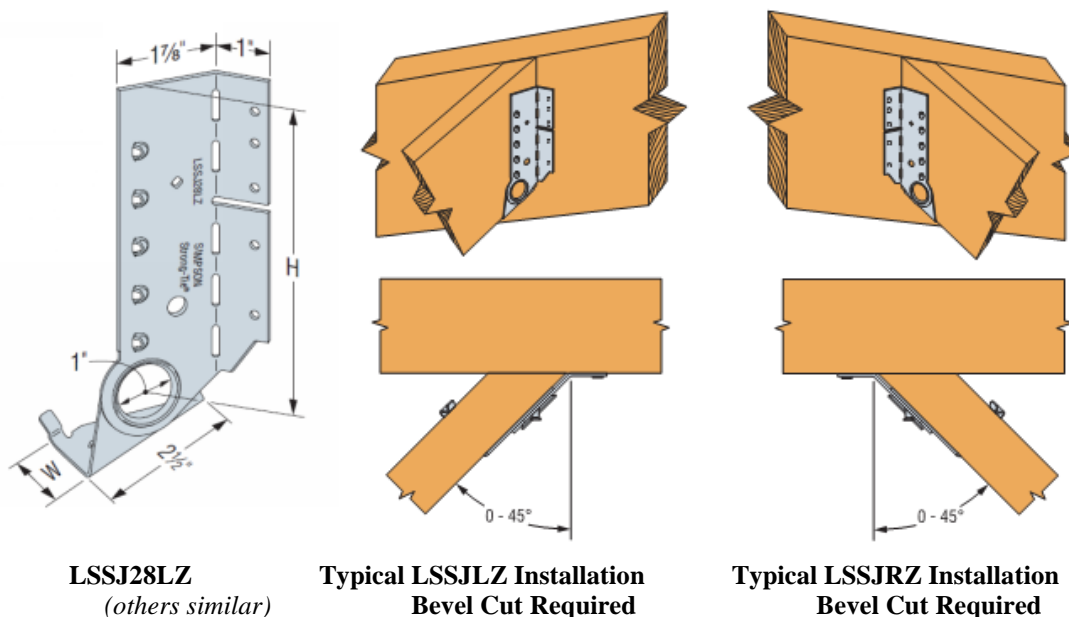

FIGURE 10—LSSJR/L FIELD ADJUSTABLE JACK HANGER



TABLE 11A—ALLOWABLE LOADS FOR THE MMHC HINGED ROOF CONNECTOR

MODEL NO.	ROOF PITCH	CONNECTOR QUANTITY	FASTENERS PER MEMBER 10d x 1 1/2" Nails	DF			
				F1	F2	F3	Uplift
				(160)	(115/125/160)	(160)	(160)
MMHC	3:12	1	5	95	485	485	480
		2	10	215	955	955	870
	12:12	1	5	65	560	455	525
		2	10	140	1215	845	940

For SI: 1 inch = 25.4 mm, 1 lbs = 4.45N

1. All installations assume a minimum single ply 2x member.
2. Double ply applications with two sided installations will achieve twice the published load for the one sided installation.
3. Linear interpolation of the loads is allowed for roof pitches between 3:12 and 12:12..

TABLE 11B—ALLOWABLE LOADS FOR THE MMHC HINGED ROOF CONNECTOR KNEEWALL APPLICATION

MODEL NO.	ROOF PITCH	CONNECTOR QUANTITY	FASTENERS PER MEMBER 10d x 1 1/2" Nails	DF	
				Download	Uplift
				(115/125/160)	(160)
MMHC	3:12 – 12:12	1	5	1145	385

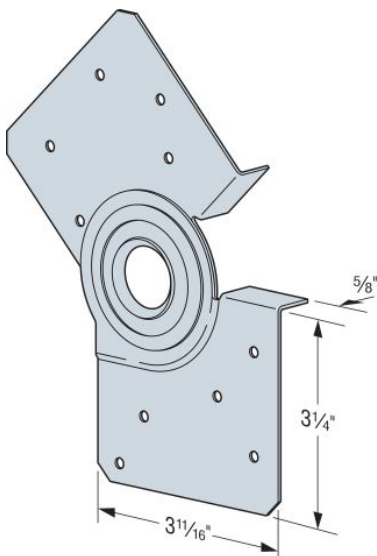

MMHC

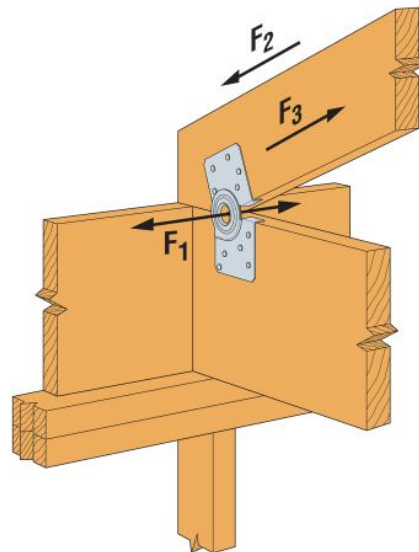

Typical MMHC Installation

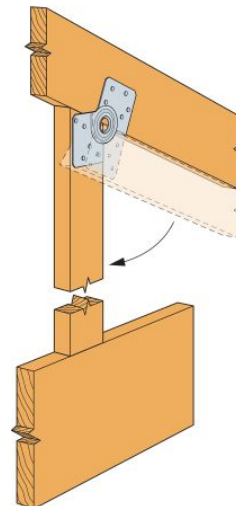

MMHC Kneewall Application

FIGURE 11 – MMHC HINGED ROOF CONNECTOR