

INSTALLATION GUIDE FOR FLOOR AND ROOF FRAMING

TJI[®] 110
TJI[®] 210
TJI[®] 230
TJI[®] 360
TJI[®] 560
Joists



WARNING:
DO NOT walk on joists
until braced. **INJURY**
MAY RESULT.



WARNING:
DO NOT walk on joists
that are lying flat.



WARNING:
DO NOT stack building
materials on unsheathed
joists. Stack only over
beams or walls.

July 2016 • Reorder TJ-9001

IMPORTANT: PLEASE READ CAREFULLY!

WARNING: JOISTS ARE UNSTABLE UNTIL BRACED LATERALLY

BRACING INCLUDES: Blocking, Hangers, Rim Board, Sheathing, Rim Joist, Strut Lines

Lack of proper bracing during construction can result in serious accidents. Observe the following guidelines:

1. Properly install all blocking, hangers, rim boards, and rim joists at TJI[®] joist end supports.
2. Establish a permanent deck (sheathing), fastened to the first 4 feet of joists at the end of the bay or braced end wall.
3. Safety bracing of 1x4 (minimum) must be nailed to a braced end wall or sheathed area and to each joist.
4. Sheathing must be completely attached to each TJI[®] joist before additional loads can be placed on the system.
5. Ends of cantilevers require safety bracing on both the top and bottom flanges.
6. The flanges must remain straight within 1/2" from true alignment.

This guide is intended for the products shown in dry-use conditions.

La Sécurité Avant Tout
AVERTISSEMENT
Lire Attentionnement

- Les solives non contreventées latéralement sont instables. Voir le guide d'installation **avant** la pose des solives TJI[®].
- Ne pas circuler sur les solives TJI[®] **avant** qu'elles ne soient adéquatement contreventées. Risque de blessure.
- Ne pas empilées des matériaux sur des solives avant d'avoir installé les sous-plancher. Les entreposer temporairement au-dessus des poutres et murs.

La Seguridad Ante Todo
ADVERTENCIA
Por Favor Lea Cuidadosamente

- Las viguetas son inestables hasta que sean reforzadas lateralmente. Vea la guía de instalaciones **antes** de instalar las viguetas TJI[®].
- No camine sobre las viguetas hasta que sean apuntaladas.
- No ponga materiales de construcción sobre las viguetas TJI[®] antes de instalar el triplay. Ponga materiales únicamente sobre vigas o muros.

FLOOR

Allowable Holes:
 Trus Joist® TJI® Joists 1
 TJI® Joist Nailing
 Requirements at Bearing 2
 Installation Recommendations 2
 TJI® Joist Floor Framing 3
 Fastening of Floor Panels 3
 Rim Board Details and Installation 4
 Floor Details 4-5
 Cantilever Details 5
 Filler and Backer Blocks 5
 Web Stiffeners 6
 Framing Connectors 8

ROOF AND WALL

Allowable Holes:
 Trus Joist® TimberStrand® LSL
 Wall Studs 2
 Web Stiffeners 6
 Typical Roof and Wall Framing 6
 Ceiling Joists 6
 Roof Details 7
 Framing Connectors 8
 Shear Blocking and Ventilation Holes 8
 TJI® Joist Nailing
 Requirements at Bearing 8

BEAM AND COLUMN

Allowable Holes:
 Trus Joist® TimberStrand® LSL,
 Parallam® PSL, Microllam® LVL
 Headers and Beams 2
 Beam and Column Details 9
 Beam and Header Bearings 9

BUILD SAFELY

We at Weyerhaeuser are committed to working safely and want to remind you to do the same. We encourage you to follow the recommendations of OSHA (www.osha.gov) in the U.S. or provincial regulations (www.canoshweb.org/en/) in Canada regarding:

- Personal protective equipment (PPE) for hands, feet, head, and eyes
- Fall protection
- Use of pneumatic nailers and other hand tools
- Forklift safety

Please adhere to the Weyerhaeuser product installation details, including the installation of safety bracing on unsheathed floors and roofs.

PRODUCT IDENTIFICATION

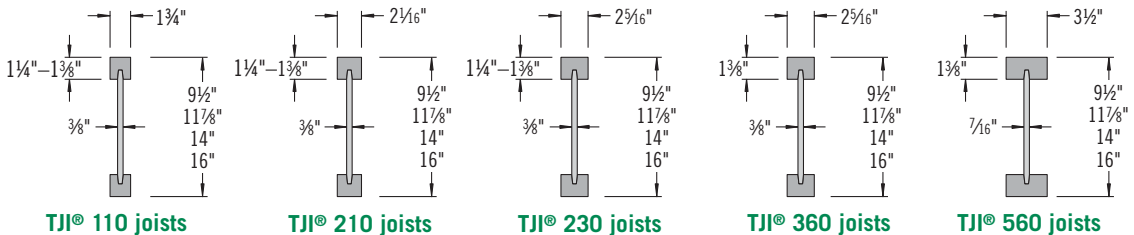

Some TJI® joist sizes may not be available in your region. Contact your Weyerhaeuser representative for more information.

ALLOWABLE HOLES—TJI® JOISTS

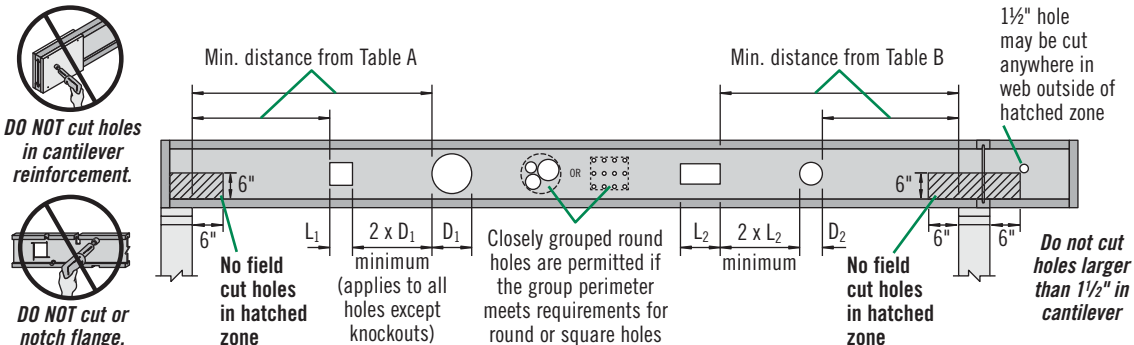

Table A—End Support: Minimum distance from edge of hole to inside face of nearest end support

Joist Depth	TJI®	Round Hole Size							Square or Rectangular Hole Size						
		2"	3"	4"	6½"	8¾"	11"	13"	2"	3"	4"	6½"	8¾"	11"	13"
9½"	110	1'-0"	1'-6"	2'-0"	5'-0"				1'-0"	1'-6"	2'-6"	4'-6"			
	210	1'-0"	1'-6"	2'-6"	5'-6"				1'-0"	2'-0"	2'-6"	5'-0"			
	230	1'-6"	2'-0"	2'-6"	5'-6"				1'-0"	2'-0"	3'-0"	5'-0"			
	360	1'-6"	2'-0"	3'-0"	6'-0"				1'-6"	2'-6"	3'-6"	5'-6"			
	560	1'-6"	2'-6"	3'-6"	7'-0"				2'-0"	3'-0"	4'-0"	6'-0"			
11½"	110	1'-0"	1'-0"	1'-6"	2'-6"	5'-6"			1'-0"	1'-6"	2'-0"	4'-6"	6'-0"		
	210	1'-0"	1'-6"	2'-0"	3'-0"	6'-0"			1'-0"	1'-6"	2'-6"	5'-0"	6'-6"		
	230	1'-0"	1'-6"	2'-0"	3'-0"	6'-6"			1'-0"	2'-0"	2'-6"	5'-6"	7'-0"		
	360	1'-6"	2'-0"	3'-0"	4'-6"	7'-0"			1'-6"	2'-6"	3'-6"	6'-6"	7'-6"		
	560	1'-6"	2'-6"	3'-0"	5'-6"	8'-0"			2'-6"	3'-6"	4'-6"	7'-0"	8'-0"		
14"	110	1'-0"	1'-0"	1'-0"	1'-6"	3'-0"	5'-6"		1'-0"	1'-0"	1'-6"	3'-6"	6'-0"	8'-0"	
	210	1'-0"	1'-0"	1'-0"	2'-0"	3'-6"	6'-0"		1'-0"	1'-0"	2'-0"	4'-0"	6'-6"	8'-6"	
	230	1'-0"	1'-0"	1'-0"	2'-6"	4'-0"	7'-0"		1'-0"	1'-0"	2'-0"	4'-0"	7'-0"	9'-0"	
	360	1'-0"	1'-0"	1'-6"	3'-6"	5'-6"	8'-0"		1'-0"	1'-6"	2'-6"	6'-0"	8'-0"	9'-6"	
	560	1'-0"	1'-0"	2'-0"	4'-6"	6'-6"	9'-0"		1'-6"	3'-0"	4'-0"	7'-0"	9'-0"	10'-0"	
16"	110	1'-0"	1'-0"	1'-0"	1'-0"	2'-0"	3'-0"	5'-0"	1'-0"	1'-0"	1'-0"	3'-0"	5'-6"	7'-6"	10'-0"
	210	1'-0"	1'-0"	1'-0"	1'-0"	2'-6"	3'-6"	6'-0"	1'-0"	1'-0"	1'-0"	3'-0"	6'-6"	8'-0"	11'-0"
	230	1'-0"	1'-0"	1'-0"	1'-6"	3'-0"	4'-0"	7'-0"	1'-0"	1'-0"	1'-0"	3'-6"	7'-0"	9'-0"	11'-0"
	360	1'-0"	1'-0"	1'-0"	2'-6"	4'-6"	6'-6"	9'-0"	1'-0"	1'-0"	1'-6"	5'-0"	9'-0"	10'-0"	11'-6"
	560	1'-0"	1'-0"	1'-0"	2'-6"	5'-0"	7'-6"	10'-0"	1'-0"	2'-0"	3'-0"	6'-6"	10'-0"	11'-0"	12'-0"

Table B—Intermediate or Cantilever Support: Minimum distance from edge of hole to inside face of nearest intermediate or cantilever support

Joist Depth	TJI®	Round Hole Size							Square or Rectangular Hole Size						
		2"	3"	4"	6½"	8¾"	11"	13"	2"	3"	4"	6½"	8¾"	11"	13"
9½"	110	2'-0"	2'-6"	3'-6"	7'-6"				1'-6"	2'-6"	3'-6"	6'-6"			
	210	2'-0"	2'-6"	3'-6"	8'-0"				1'-0"	3'-0"	4'-0"	7'-6"			
	230	2'-6"	3'-0"	4'-0"	8'-6"				2'-0"	3'-6"	4'-6"	7'-6"			
	360	3'-0"	4'-0"	5'-6"	9'-0"				3'-0"	4'-6"	5'-6"	8'-0"			
	560	3'-6"	5'-0"	6'-0"	10'-0"				4'-0"	5'-6"	6'-6"	9'-0"			
11½"	110	1'-0"	1'-0"	1'-6"	4'-0"	8'-6"			1'-0"	1'-6"	2'-6"	7'-0"	9'-6"		
	210	1'-0"	1'-0"	2'-0"	4'-6"	9'-0"			1'-0"	2'-0"	3'-0"	8'-0"	10'-0"		
	230	1'-0"	2'-0"	2'-6"	5'-0"	10'-0"			1'-0"	2'-6"	3'-6"	8'-6"	10'-6"		
	360	2'-0"	3'-0"	4'-0"	7'-0"	11'-0"			2'-0"	3'-6"	5'-0"	9'-6"	11'-0"		
	560	1'-6"	3'-0"	4'-6"	8'-0"	12'-0"			3'-0"	4'-6"	6'-0"	10'-6"	12'-0"		
14"	110	1'-0"	1'-0"	1'-0"	2'-0"	4'-6"	8'-6"		1'-0"	1'-0"	1'-0"	5'-0"	9'-0"	12'-0"	
	210	1'-0"	1'-0"	1'-0"	2'-6"	5'-6"	9'-6"		1'-0"	1'-0"	2'-0"	6'-0"	10'-0"	13'-0"	
	230	1'-0"	1'-0"	1'-0"	3'-6"	6'-0"	10'-6"		1'-0"	1'-0"	2'-6"	6'-6"	11'-0"	13'-6"	
	360	1'-0"	1'-0"	2'-0"	5'-6"	8'-6"	12'-6"		1'-0"	2'-0"	4'-0"	9'-0"	12'-0"	14'-0"	
	560	1'-0"	1'-0"	1'-6"	5'-6"	9'-6"	13'-6"		1'-0"	3'-0"	5'-0"	10'-0"	13'-6"	15'-0"	
16"	110	1'-0"	1'-0"	1'-0"	1'-0"	2'-6"	5'-0"	8'-6"	1'-0"	1'-0"	1'-0"	3'-6"	8'-6"	11'-6"	15'-0"
	210	1'-0"	1'-0"	1'-0"	1'-0"	3'-6"	6'-0"	10'-0"	1'-0"	1'-0"	1'-0"	4'-6"	10'-0"	12'-6"	16'-0"
	230	1'-0"	1'-0"	1'-0"	1'-6"	4'-0"	6'-6"	11'-0"	1'-0"	1'-0"	1'-0"	5'-0"	10'-6"	13'-6"	16'-6"
	360	1'-0"	1'-0"	1'-0"	3'-0"	6'-6"	10'-0"	13'-6"	1'-0"	1'-0"	2'-0"	7'-6"	13'-0"	14'-6"	17'-0"
	560	1'-0"	1'-0"	1'-0"	2'-6"	7'-0"	11'-0"	15'-0"	1'-0"	1'-0"	3'-6"	9'-0"	14'-6"	16'-0"	18'-0"

- Leave ¼" of web (minimum) at top and bottom of hole. **DO NOT cut joist flanges.**
- Tables are based on uniform load tables in current design literature.
- For simple span (5' minimum), uniformly loaded joists used in residential applications, one maximum size round hole may be located at the center of the joist span **provided that no other holes occur in the joist.**

1.55E TimberStrand® LSL Headers and Beams

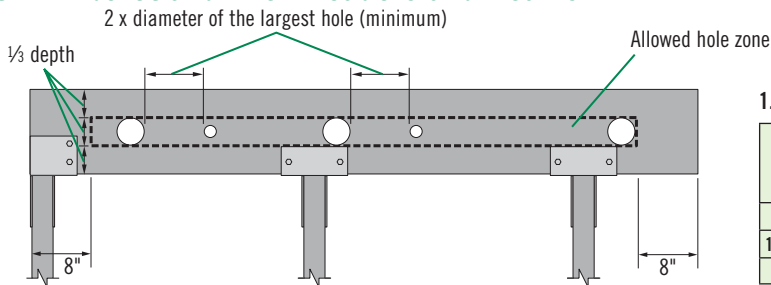

1.55E TimberStrand® LSL

Header or Beam Depth	Maximum Round Hole Size
9¼"–9½"	3"
11¼"–11⅞"	3⅝"
14"–16"	4⅝"

▪ See illustration for allowed hole zone.

GENERAL NOTES

- Allowed hole zone suitable for headers and beams with **uniform and/or concentrated loads** anywhere along the member.
- Round holes only.
- No holes in headers or beams in plank orientation.

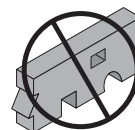

DO NOT cut, notch, or drill holes in headers or beams except as indicated in the illustrations and tables.

Other Trus Joist® Headers and Beams

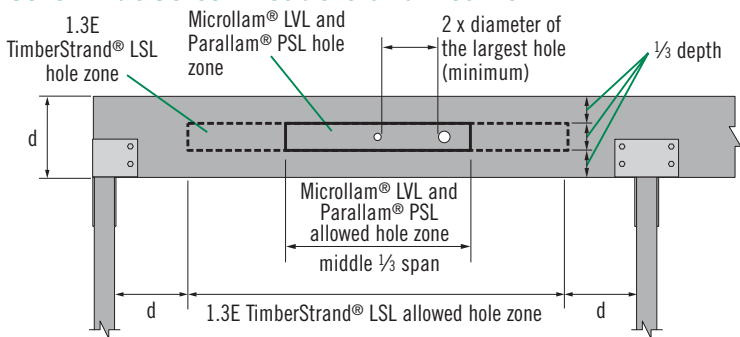

Other Trus Joist® Beams

Header or Beam Depth	Maximum Round Hole Size
4⅜"	1"
5½"	1¾"
7¼"–20"	2"

▪ See illustration for allowed hole zone.

GENERAL NOTES

- Allowed hole zone suitable for headers and beams with **uniform loads only**.
- Round holes only.
- No holes in cantilevers.
- No holes in headers or beams in plank orientation.

TimberStrand® LSL Wall Studs

One notch may be cut anywhere except the middle ⅓ of the length of the stud or column. Holes may be drilled anywhere along the length of the stud or column but must be at least ⅝" from the edge.

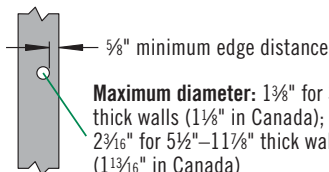

Maximum diameter: 1⅜" for 3½" thick walls (1⅜" in Canada); 2⅜" for 5½"–11⅞" thick walls (1⅜" in Canada)



Maximum notch: ⅞" for 3½" thick walls 1⅜" for 5½"–11⅞" thick walls



DO NOT cut a notch and a hole in the same cross section.

TJI® JOIST NAILING REQUIREMENTS AT BEARING

TJI® Joist to Bearing Plate

1½" TJI® Rim Board or 1¼" TimberStrand® LSL

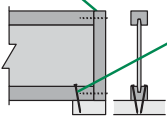

One 8d (0.113" x 2½") nail each side. Drive nails at an angle at least 1½" from end.

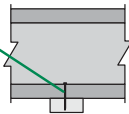

1¾" minimum end bearing for single-family applications

3½" minimum intermediate bearing; 5¼" may be required for maximum capacity

- Increased bearing capacities may be achieved with increased bearing lengths. See plans for required bearing lengths.

Shear transfer nailing: Use connections equivalent to floor panel nailing schedule. See page 4.

Squash Blocks to TJI® Joist (Load bearing wall above)

One 10d (0.128" x 3") nail into each flange

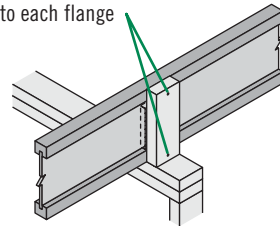

Also see detail B2, page 5

Rim to TJI® Joist

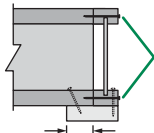

1½" TJI® Rim Board, 1¼" TimberStrand® LSL, or TJI® 110 rim joist:
One 10d (0.131" x 3") nail into each flange
TJI® 210, 230, and 360 rim joist:
One 16d (0.135" x 3½") nail into each flange

1¾" minimum bearing

Locate rim board joint between joists

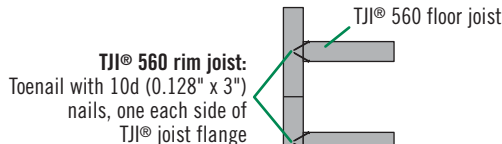

TJI® 560 rim joist:
Toenail with 10d (0.128" x 3") nails, one each side of TJI® joist flange

Top View

TJI® 560 rim joist

INSTALLATION RECOMMENDATIONS

RECOMMENDED COMPONENTS

- Weyerhaeuser Edge Gold™ floor panels
- TJI® joists
- 1½" TJI® Rim Board or 1¼" TimberStrand® LSL

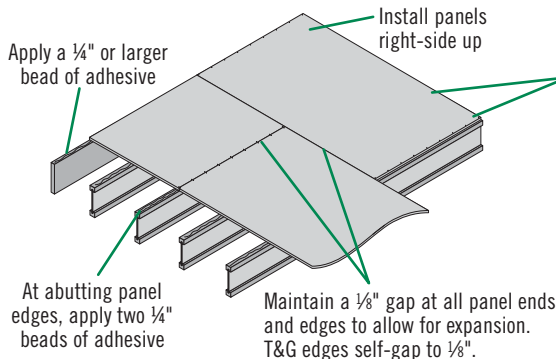

RECOMMENDED ADHESIVES

- Weyerhaeuser recommends using solvent-based subfloor adhesives that meet ASTM D3498 (AFG-01) performance standards. When latex subfloor adhesive is required, careful selection is necessary due to a wide range of performance between brands.

Nail panel to joist at 12" on-center in field and 6" on-center along panel edges. Apply fasteners ¾" from panel edges.

- For ¾" panels, use 8d (0.131" x 2½") or 6d (0.120" x 2") deformed-shank nails or other code-approved fasteners.
- For ⅞" panels, use 8d (0.131" x 2½") or 8d (0.120" x 2½") deformed-shank nails or other code-approved fasteners.
- Fully nail floor panel within 10 minutes of applying adhesive (or sooner if required by adhesive manufacturer).
- Screws may be substituted for the nails noted above if the screws have equivalent lateral load capacity.

TJI® joist floor framing does not require bridging or mid-span blocking



DO NOT use sawn lumber for rim board or blocking as it may shrink after installation. Use only engineered lumber.

See **Filler and Backer Blocks** on page 5

Joists must be laterally supported at cantilever and end bearings by blocking panels, hangers, or direct attachment to a rim board or rim joist.

WARNING
Joists are unstable until laterally braced. See Warning on cover.

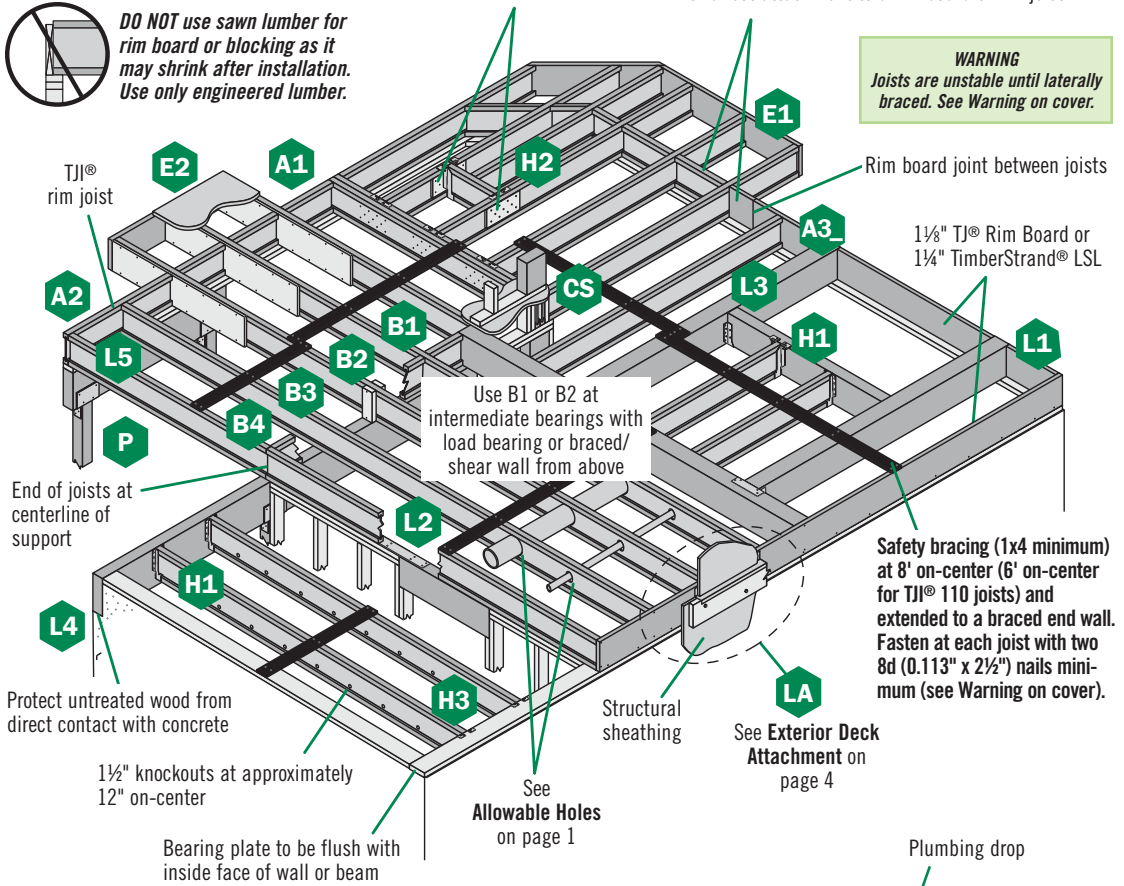

INSTALLATION TIPS

- Subfloor adhesive will improve floor performance, but may not be required.
- Squash blocks and blocking panels carry stacked vertical loads (details B1 and B2). Packing out the web of a TJI® joist (with web stiffeners) is not a substitute for squash blocks or blocking panels.
- When joists are doubled at non-load bearing parallel partitions, space joists apart the width of the wall for plumbing or HVAC.
- Additional joist at plumbing drop (see detail at right).

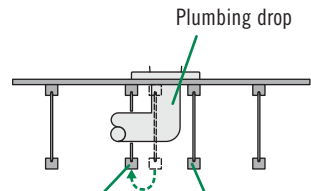

Joist may be shifted up to 3" if floor panel edge is supported and span rating is not exceeded. **Do not cut joist flanges.**

Additional joist is required if floor panel edge is unsupported or if span rating is exceeded.

DETAIL SCHEDULE

End bearings (see page 4)

- A1** with blocking panels
- A2** with TJI® rim joist
- A3** with rim board

Intermediate bearings* (see page 5)

- B1** with blocking panels to support load bearing wall above
- B2** with squash blocks to support load bearing wall above
- B3** without blocking panels or squash blocks (no wall above)

Cantilever details (see page 5)

- E1** no reinforcement
- E2** ¾" reinforcement on one side

- E3** ¾" reinforcement both sides
- E4** joist reinforcement
- F1** deck cantilever
- PB1** permanent bracing

Cantilevers less than 5" (see page 5)

- E5** ¾" reinforcement on one side, with vertical blocking
- E6** ¾" reinforcement both sides, with vertical blocking
- E7** ¾" reinforcement on one side, with horizontal blocking
- E8** ¾" reinforcement on both sides, with horizontal blocking
- E9** horizontal blocking, no reinforcement

Hanger Details

(more connector information on page 8)

- H1** TJI® joist to beam (see page 8)
- H2** TJI® joist to joist (see page 5)
- H3** TJI® joist on masonry wall or steel beam (see page 8)

Other details

- B4** butting joists with blocking panels (see above)
- CS** column support (see page 4)
- LA** exterior deck attachment (see page 4)
- W** web stiffeners (see page 6)
- L** beam details (see page 9)
- P** column details (see page 9)

*Load bearing wall must stack over wall below. Blocking panels may be required at braced/shear walls above or below.

JAVELIN® SOFTWARE FRAMING PLANS



Web stiffeners required on each side of joist at bearing. Refer to your Javelin® framing plan.

Bearing requirements as shown on the Javelin® framing plan are job-specific and supersede minimum bearing requirements listed.

FASTENING OF FLOOR PANELS

Guidelines for Closest On-Center Spacing per Row

Nail Size	TJI®(1)(2)		Rim board		1½" TimberStrand® LSL or wider	Microllam® LVL	Parallam® PSL
	110, 210, and 230	360 and 560	1½" TJI®	1¼" TimberStrand® LSL			
8d (0.113" x 2½"), 8d (0.131" x 2½")	4"	3"	6"	4"	3"	4"	4"
10d (0.148" x 3"), 12d (0.148" x 3¼")	4 ⁽³⁾ "	4 ⁽³⁾ "	6"	4"	4"	5"	4"
16d (0.162" x 3½")	6"	6"	16 ⁽⁴⁾ "	6 ⁽⁵⁾ "	6 ⁽⁵⁾ "	8 ⁽⁴⁾ "	6"

- (1) Stagger nails when using 4" on-center spacing and maintain ¾" joist and panel edge distance. One row of fasteners is permitted (two at abutting panel edges) for diaphragms. Fastener spacing for TJI® joists in diaphragm applications cannot be less than shown in table. When fastener spacing for blocking is less than spacing shown above, rectangular blocking must be used in lieu of TJI® joists.
- (2) For non-diaphragm applications, multiple rows of fasteners are permitted if the rows are offset at least ½" and staggered.
- (3) With 10d (0.148" x 1½") nails, spacing can be reduced to 3" on-center for light gauge steel straps.
- (4) Can be reduced to 5" on-center if nail penetration into the narrow edge is no more than 1¼" (to minimize splitting).
- (5) Can be reduced to 4" on-center if nail penetration into the narrow edge is no more than 1¼" (to minimize splitting).

- Recommended nailing is 12" on-center in field and 6" on-center along panel edge. Fastening requirements on engineered drawings supersede recommendations listed above.
- Maximum nail spacing for TJI® joists is 18" on-center.
- 14 ga. staples may be substituted for 8d (0.113" x 2½") nails if minimum penetration of 1" into the TJI® joist or rim board is achieved.
- To minimize splitting, maintain edge distance and row spacing of 2½ x nail diameter or ¾", whichever is greater. Multiple rows must be staggered and equally spaced from the centerline of the narrow face axis.
- For recommended nailing and adhesives, see **INSTALLATION RECOMMENDATIONS** on page 2.

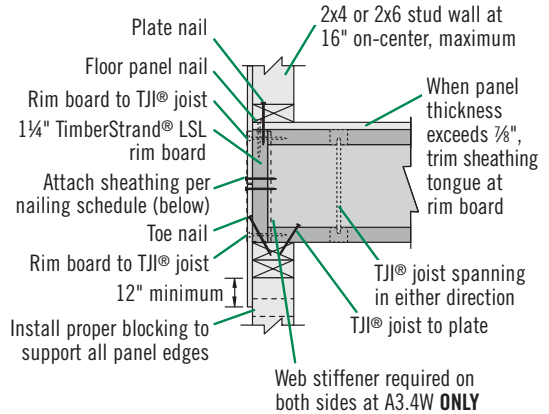
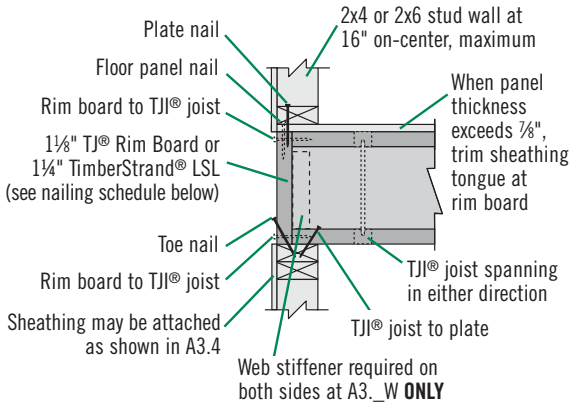

Specifications	Rim Board Installation Detail ⁽¹⁾⁽²⁾			
	A3.1	A3.2	A3.3	A3.4
Minimum Rim Board Thickness	1 1/8"	1 1/4"	1 1/4"	1 1/4"
Plate Nail—16d (0.135" x 3 1/2")	16" o.c.	16" o.c.	16" o.c.	16" o.c.
Floor Panel Nail—8d (0.131" x 2 1/2")	6" o.c.			
Rim Board to TJI Joist—10d (0.131" x 3")	One into each flange			
Toe Nail—10d (0.131" x 3")	6" o.c.	6" o.c.	4" o.c.	6" o.c.
TJI Joist to Plate—8d (0.113" x 2 1/2")	Two nails driven at an angle into bottom flange, one each side of web at least 1 1/2" from end			
Wall Framing	Sheathing		7/16" structural 1 sheathing ⁽³⁾	3/8" structural 1 sheathing in all areas ⁽⁴⁾
	Boundary Nailing		8d (0.131" x 2 1/2") at 6" o.c.	8d (0.131" x 2 1/2") at 4" o.c.
	Intermediate Nailing		8d (0.131" x 2 1/2") at 12" o.c.	
Maximum Lateral Load (plf)	220 ⁽⁵⁾	300 ⁽⁵⁾	350 ⁽⁶⁾	560 ⁽⁶⁾

- (1) All sheathing must be properly blocked and nailed.
- (2) Verify the lateral capacity of the wall. Not all types of code-allowed wall construction provide the same lateral resistance. Check with your local building officials or the design professional of record.
- (3) Detail A3.3 must be a segmented wall, location of full-height structural sheathing per code.
- (4) Sheathing must be continuous over all plate-to-plate and plate-to-rim board interfaces and may butt together at mid-depth of rim board as shown in A3.4. At foundation, fasten the bottom edge of the sheathing to the sill plate.
- (5) Maximum lateral load capacities are for seismic design applications. No further increases for duration of load are allowed, except loads may be increased by a factor of 1.4 for wind design applications.
- (6) Capacities must not be increased for duration of load.

FLOOR DETAILS

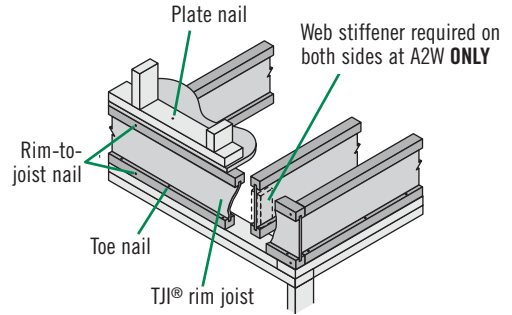
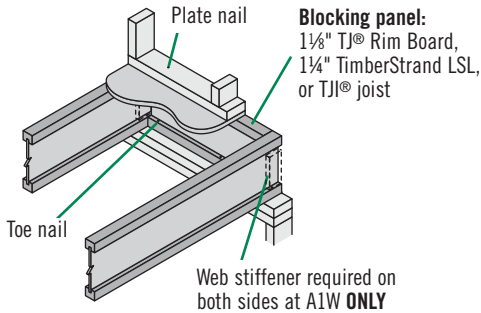

A1 **A1W** Attach blocking per A3.1 in rim board installation table above

A2 **A2W** Must have 1 1/4" minimum joist bearing at ends. Attach rim joist per A3.1 in rim board installation table above.

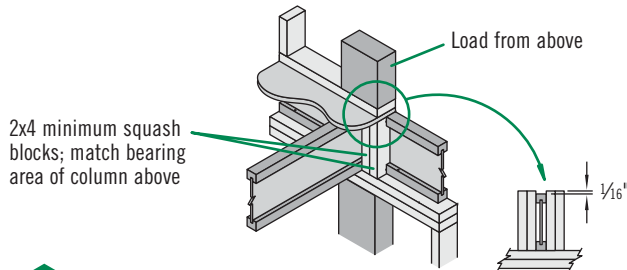

CS Use 2x4 minimum squash blocks to transfer load around TJI joist

Exterior Deck Attachment

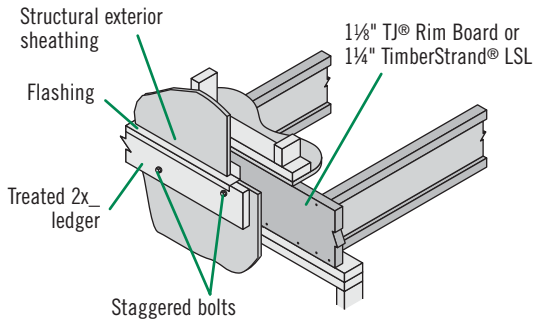

Shimmed Deck Attachment

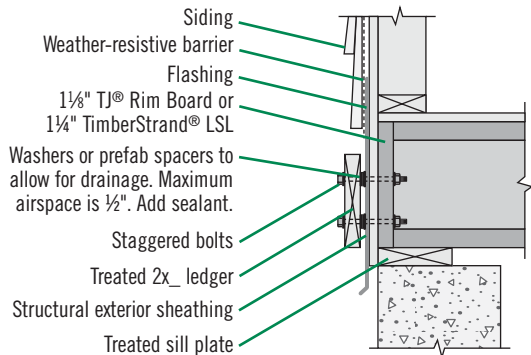

LA Corrosion-resistant fasteners required for wet-service applications

Maintain 2" distance (minimum) from edge of ledger to edge of fastener. Stagger bolts.

Load bearing or braced/shear wall above (must stack over wall below)

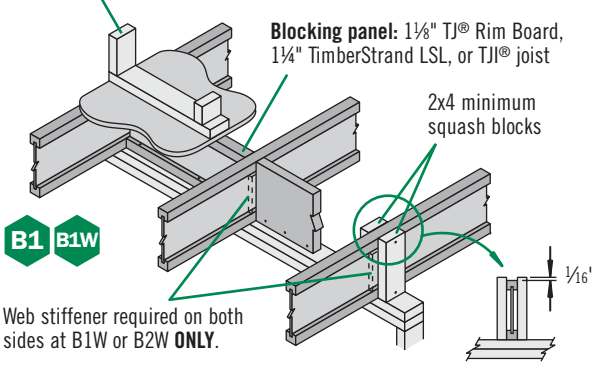

No load bearing wall above

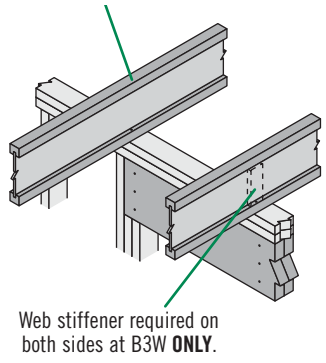

B2 B2W Blocking panels may be required with braced/shear walls above or below—see detail B1

B3 B3W Blocking panels may be required with braced/shear walls above or below—see detail B1

CANTILEVER DETAILS

At PB1, cantilever back span must be permanently braced with either direct-applied ceiling along entire length or permanent bracing at 1/3 points. See detail below for connections.

8" diameter maximum hole for 11⅞"–16" deep blocking panels; 6" diameter maximum for blocking panels 9½" deep or shorter than 12" long. **Do not cut flanges.**

1½" TJ® Rim Board or 1¼" TimberStrand® LSL closure, typical

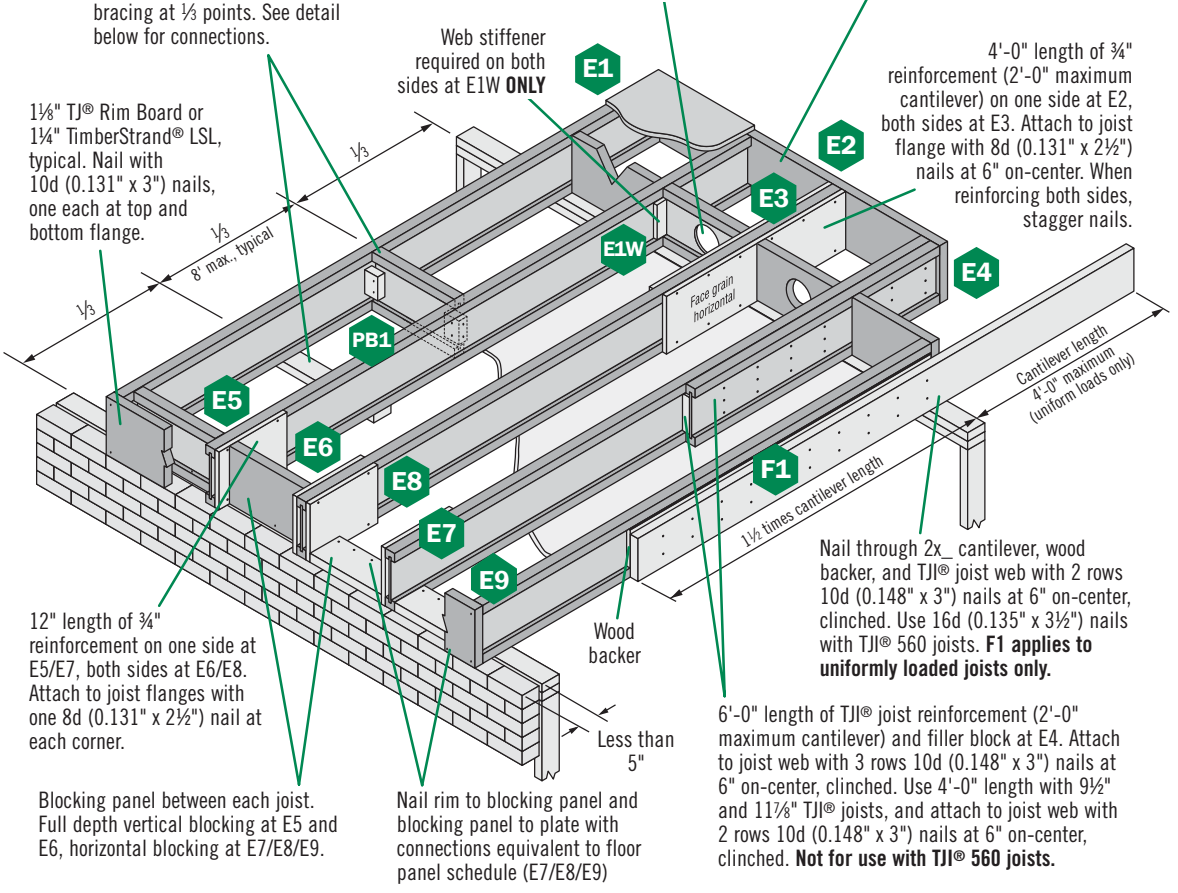

Two 2½" screws for 2x strapping connections

When specified on the layout, one of the bracing options shown at right is required

PB1

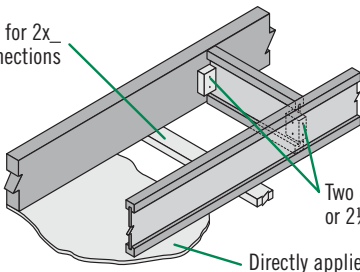

Apply subfloor adhesive to all contact surfaces

FILLER AND BACKER BLOCKS

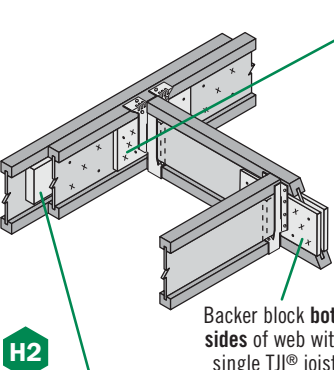

HANGER BACKER BLOCK

Install tight to top flange (tight to bottom flange with face mount hangers).

- **Single-Family Applications:** Attach with ten 10d (0.128" x 3") nails, clinched when possible.
- **Multi-Family Applications:** Attach with fifteen 10d (0.128" x 3") nails, clinched when possible.

DOUBLE TJJ® JOIST FILLER BLOCK

- **Single-Family Applications:** Attach with ten 10d (0.128" x 3") nails, clinched. Use ten 16d (0.135" x 3½") nails from each side with TJJ® 560 joists.
- **Multi-Family Applications:** Attach with fifteen 10d (0.128" x 3") nails, clinched. Use fifteen 16d (0.135" x 3½") nails from each side with TJJ® 560 joists.

Filler and Backer Block Sizes

TJJ®	110		210		230 or 360		560	
Depth	9½" or 11⅞"	14" or 16"	9½" or 11⅞"	14" or 16"	9½" or 11⅞"	14" or 16"	9½" or 11⅞"	14" or 16"
Filler Block⁽¹⁾ (Detail H2)	2x6	2x8	2x6 + ⅜" sheathing	2x8 + ⅜" sheathing	2x6 + ½" sheathing	2x8 + ½" sheathing	Two 2x6	Two 2x8
Cantilever Filler (Detail E4)	2x6 4'-0" long	2x10 6'-0" long	2x6 + ⅜" sheathing 4'-0" long	2x10 + ⅜" sheathing 6'-0" long	2x6 + ½" sheathing 4'-0" long	2x10 + ½" sheathing 6'-0" long	Not applicable	
Backer Block⁽¹⁾ (Detail F1 or H2)	⅝" or ¾"		¾" or ⅞"		⅞" or 1" net		2x6	2x8

(1) If necessary, increase filler and backer block height for face mount hangers and maintain 1/8" gap at top of joist. See detail W. Filler and backer block dimensions should accommodate required nailing without splitting. The suggested minimum length is 24" for filler and 12" for backer blocks.

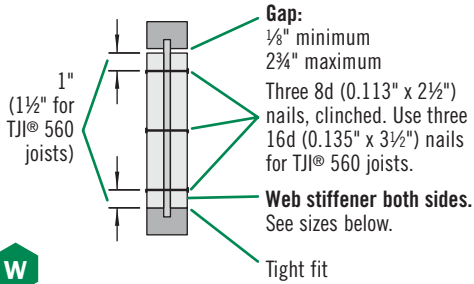

WEB STIFFENER SIZES

- **TJI® 110 joists:** 5/8" x 2 5/16" minimum⁽¹⁾
- **TJI® 210 joists:** 3/4" x 2 5/16" minimum⁽¹⁾
- **TJI® 230 and 360 joists:** 7/8" x 2 5/16" minimum⁽¹⁾
- **TJI® 560 joists:** 2x4, construction grade or better

(1) PS1 or PS2 sheathing, face grain vertical

WEB STIFFENER REQUIREMENTS

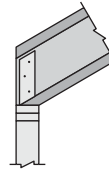

Required at all birdsmouth cuts.

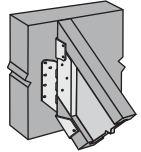

Required at all sloped hangers.



Required if the sides of the hanger do not extend to laterally support at least 3/8" of the TJI® joist top flange.

Only required at intermediate bearing locations when noted on framing plan.

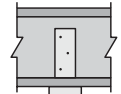

TYPICAL ROOF AND WALL FRAMING

DETAIL SCHEDULE

Roof details (see page 7)

- R1** on bevel plate
- R1 W** on bevel plate with web stiffeners
- R3** with variable slope seat connector
- R3 W** with seat connector and web stiffeners
- R5** with birdsmouth cut
- R7** intermediate bearing
- R7 W** intermediate bearing with web stiffeners

- R8** 2x4 outrigger and filler with birdsmouth cut
- R9** 2x4 outrigger without filler
- R10** 2x4 outrigger with filler
- R10 W** 2x4 outrigger with filler and web stiffeners
- R14** ridge detail
- R14 W** ridge detail, with web stiffeners

Other details

- O** 2x_ overhang at end wall
 - SB** shear blocking (see page 8)
 - W** web stiffeners
- Hanger details (see page 8)**
- H5** slope adjusted hanger
 - H6** header on slope

Joists must be laterally supported at cantilever and end bearings by blocking panels, hangers, or direct attachment to a rim board or rim joist.

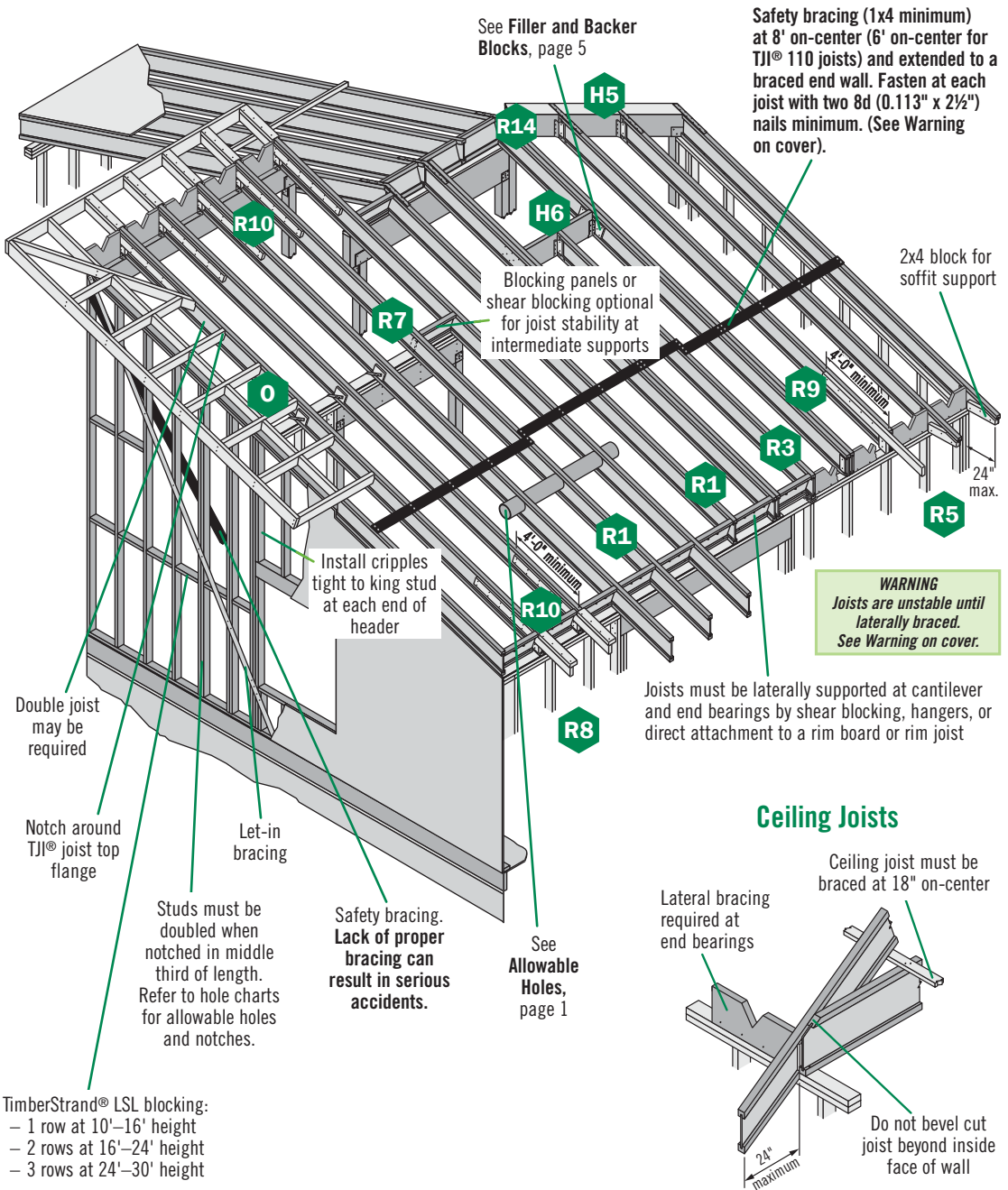

See **Filler and Backer Blocks**, page 5

Safety bracing (1x4 minimum) at 8' on-center (6' on-center for TJI® 110 joists) and extended to a braced end wall. Fasten at each joist with two 8d (0.113" x 2½") nails minimum. (See **Warning** on cover).

Blocking panels or shear blocking optional for joist stability at intermediate supports

2x4 block for soffit support

Install cripples tight to king stud at each end of header

WARNING
Joists are unstable until laterally braced.
See **Warning** on cover.

Joists must be laterally supported at cantilever and end bearings by shear blocking, hangers, or direct attachment to a rim board or rim joist

Double joist may be required

Notch around TJI® joist top flange

Let-in bracing

Studs must be doubled when notched in middle third of length. Refer to hole charts for allowable holes and notches.

Safety bracing. **Lack of proper bracing can result in serious accidents.**

See **Allowable Holes**, page 1

Ceiling Joists

Ceiling joist must be braced at 18" on-center

Lateral bracing required at end bearings

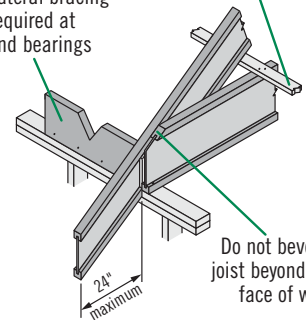

Do not bevel cut joist beyond inside face of wall

TimberStrand® LSL blocking:
– 1 row at 10'–16' height
– 2 rows at 16'–24' height
– 3 rows at 24'–30' height

Shear blocking:

1 1/8" TJI® Rim Board,
1 1/4" TimberStrand® LSL,
or TJI® joist

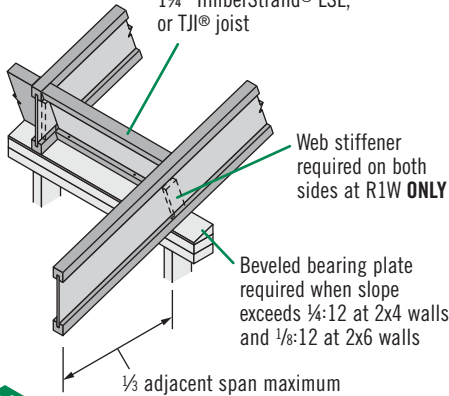

R1 R1W

V-cut shear blocking:
1 1/4" TimberStrand® LSL
rim board

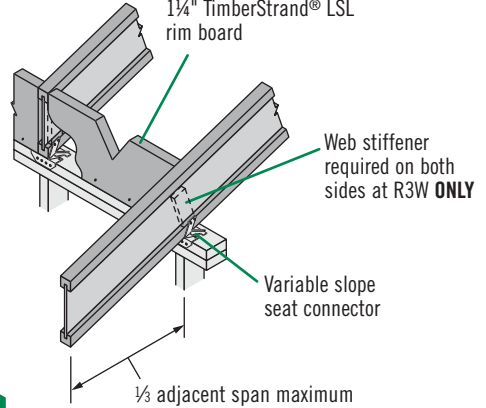

R3 R3W

Intermediate Bearing

Blocking panels or shear blocking may be specified for joist stability at intermediate supports

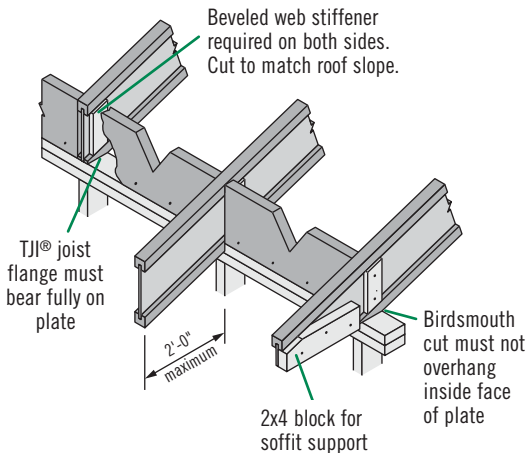

R5 Birdsmouth cut allowed at low end of joist only

Web stiffener required on both sides at R7W ONLY

Twist strap and backer block required at R7S with slopes greater than 3:12. See **Nailing Requirements**, page 8.

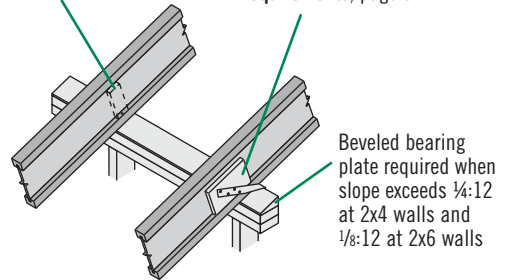

R7 R7W R7S

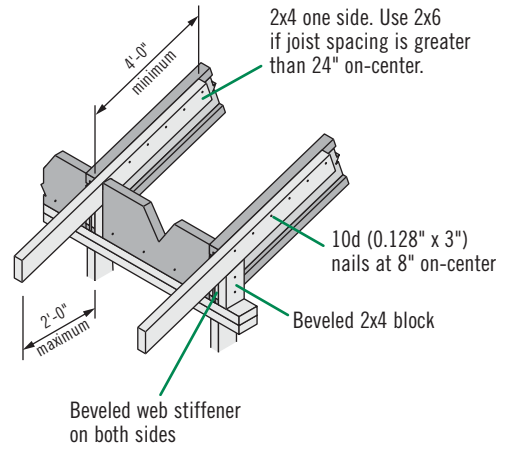
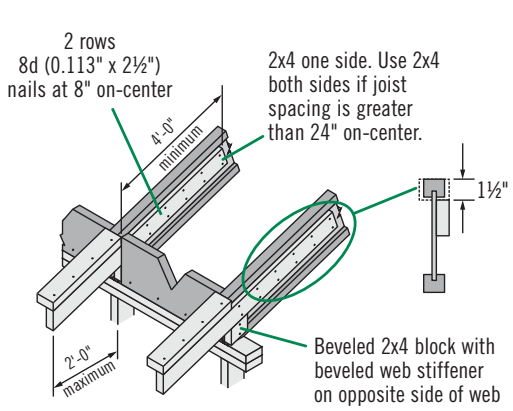

R8 Birdsmouth cut allowed at low end of joist only

R9 Birdsmouth cut allowed at low end of joist only

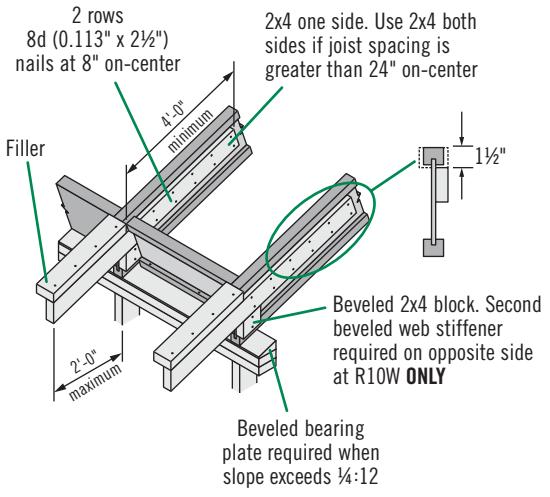

R10 **R10W**

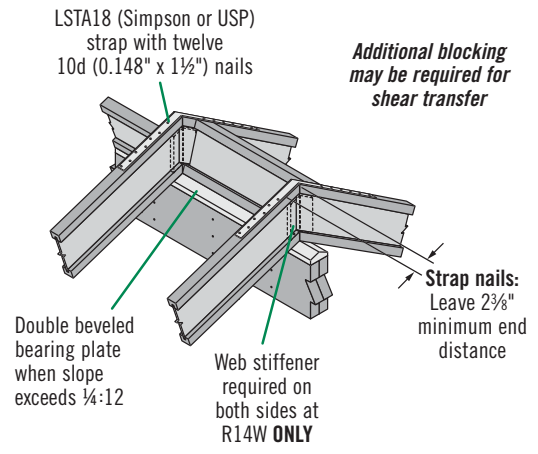

R14 **R14W**

APPROVED HANGERS

- The following manufacturers are approved to supply hangers for Trus Joist® products:
 - Simpson Strong-Tie Co., Inc.: 1-800-999-5099
 - USP Structural Connectors: 1-800-328-5934
- Hanger design loads differ by support type and may exceed the capacity of the support and/or supported member. Contact your Weyerhaeuser representative or refer to Weyerhaeuser software.

NAILING REQUIREMENTS

- Fill all round, dimple, and positive angle holes with the proper nails. Hanger nails are usually a heavier gauge because of the higher loads they need to carry.
- Unless specified otherwise, full capacity of straps and connectors can only be achieved if the following nail penetration is provided:

	FACE MOUNT	TOP MOUNT
10d (0.148" x 1½")	1½" minimum	1½" minimum
10d (0.148" x 3")	1½" minimum, clinched	3" minimum
16d (0.162" x 3½")	1¾" minimum, clinched	3½" minimum

- Top mount hangers should be fastened to TJI® joist headers with 10d (0.148" x 1½") nails. Fasten face mount hangers to 3½" or wider TJI® joist headers with 10d (0.148" x 3") or 16d (0.162" x 3½") nails.

CONNECTOR INSTALLATION AND SQUEAK PREVENTION TIPS

- Nails must be completely set.
- Leave 1/16" clearance between the member and the support member or hanger.
- Joist to beam connections require hangers; do not toenail.
- Install the supported member tight to the bottom of the hanger. Reduce squeaks by adding subfloor adhesive to the hanger seat.
- On Simpson Strong-Tie® VPA connectors, bend the bottom flange tabs over and nail to TJI® joist bottom flange.

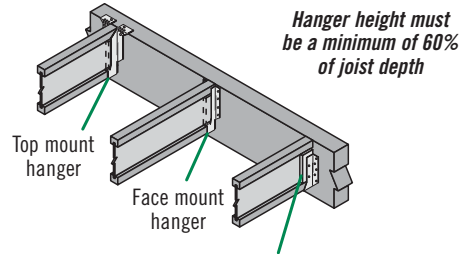

H1

Web stiffeners required if the sides of the hanger do not laterally support at least 3/8" of the TJI® joist top flange

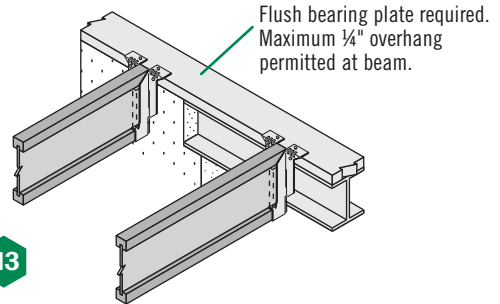

H3

LSTA24 (Simpson or USP) strap with twelve 10d (0.148" x 1½") nails required at H5S with slopes greater than 3:12

Additional blocking may be required for shear transfer

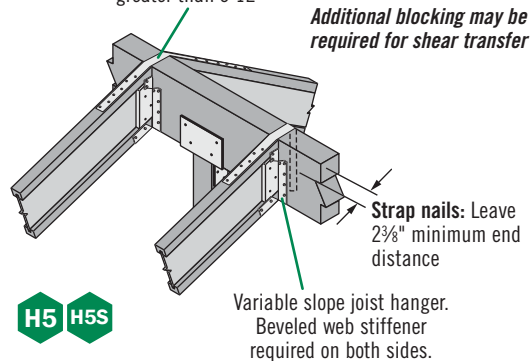

H5 H5S

Variable slope joist hanger. Beveled web stiffener required on both sides.

Filler block: Attach with ten 10d (0.128" x 3") nails, clinched. Use ten 16d (0.135" x 3½") nails from each side with TJI® 560 joists.

Backer block: Install tight to bottom flange (tight to top flange with top mount hangers). Attach with ten 10d (0.128" x 3") nails, clinched when possible.

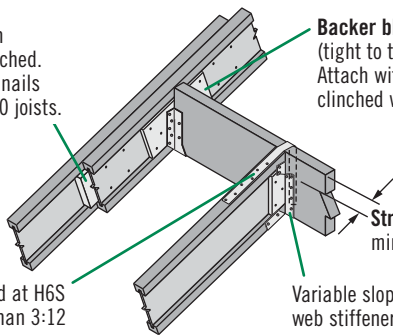

Strap nails: Leave 2⅜" minimum end distance

LSTA18 strap required at H6S with slopes greater than 3:12

Variable slope joist hanger. Beveled web stiffeners required on both sides.



SHEAR BLOCKING AND VENTILATION HOLES (Roof Only)

TJI® Rim Board or TimberStrand® LSL for shear blocking (between joists). Field trim to match joist depth at outer edge of wall or locate on wall to match joist depth.

For TJI® joists with slopes of 10:12 to 12:12, the vertical depth of shear blocking at bearing will require 1⅝" TJI® Rim Board or 1¼" TimberStrand® LSL that is one size deeper than the TJI® joist. DO NOT use 1⅝" TJI® Rim Board in ventilation-hole applications.

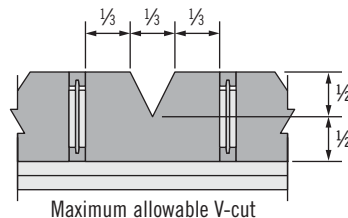
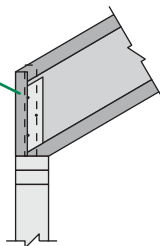

TJI® JOIST NAILING REQUIREMENTS AT BEARING

TJI® Joist to Bearing Plate

END BEARING
(1¼" minimum bearing required)

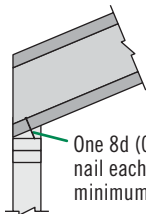

One 8d (0.113" x 2½") nail each side, 1½" minimum from end

When slope exceeds ¼:12, a beveled bearing plate, variable slope seat connector, or birdsmouth cut (at low end of joist only) is required.

INTERMEDIATE BEARING
(3½" minimum bearing required)

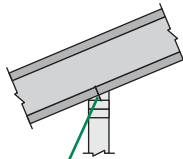

Slopes 3:12 or less:
One 8d (0.113" x 2½") nail each side. See detail R7.

Slopes greater than 3:12:
Two 8d (0.113" x 2½") nails each side, plus a twist strap and backer block. See detail R7S.

When slope exceeds ¼:12 for a 2x4 wall or ⅙:12, for a 2x6 wall, a beveled bearing plate or variable slope seat connector is required.

Blocking to Bearing Plate

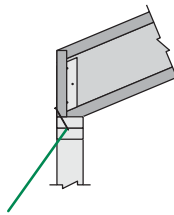

1⅝" TJI® Rim Board or 1¼" TimberStrand® LSL:
Toenail with 10d (0.131" x 3") nails at 6" on-center or 16d (0.135" x 3½") nails at 12" on-center

TJI® joist blocking:
10d (0.128" x 3") nails at 6" on-center
Shear transfer nailing:
Minimum, use connections equivalent to sheathing nail schedule

Bearing length is extremely critical and must be considered for each application. See Minimum Bearing Length table below for minimum end and intermediate bearing lengths, and your Javelin® framing plan, if applicable.

This guide is intended for the products shown in dry-use conditions

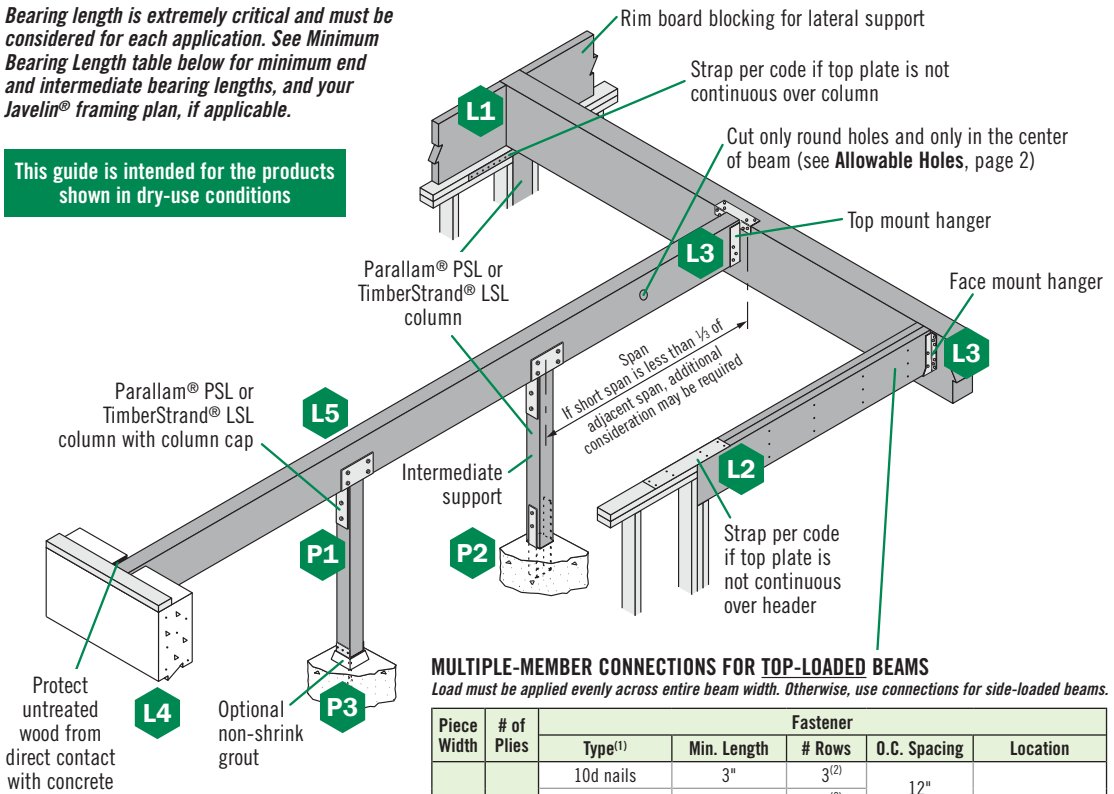

MULTIPLE-MEMBER CONNECTIONS FOR TOP-LOADED BEAMS

Load must be applied evenly across entire beam width. Otherwise, use connections for side-loaded beams.

Piece Width	# of Plies	Fastener				
		Type ⁽¹⁾	Min. Length	# Rows	O.C. Spacing	Location
1 3/4"	2	10d nails	3"	3 ⁽²⁾	12"	One side
		12d–16d nails	3 3/4"	2 ⁽²⁾		
		Screws	3 3/8" or 3 1/2"	2	24"	
	3	10d nails	3"	3 ⁽²⁾	12"	Both sides
			12d–16d nails	3 3/4"		
		Screws	3 3/8" or 3 1/2"	2	24"	Both sides One side
			5"			
	4	10d nails ⁽³⁾	3"	3 ⁽²⁾	12"	One side (per ply)
			12d–16d nails ⁽³⁾	3 3/4"		
		Screws	5" or 6"	2	24"	Both sides One side
6 3/4"						
3 1/2"	2	Screws	5" or 6"	2	24"	Both sides
		Screws	6 3/4"			One side
	1/2" bolts	8"	2	24"	—	

When fasteners are required on both sides, stagger fasteners on the second side so they fall halfway between fasteners on the first side.

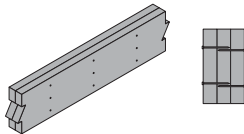

L6 Multiple pieces can be nailed or bolted together, up to a maximum width of 7"

MULTIPLE-MEMBER CONNECTIONS FOR SIDE-LOADED BEAMS

- Additional nailing or bolting may be required with side-loaded multiple-member beams. Refer to current product literature.

- 10d nails are 0.128" diameter; 12d–16d nails are 0.148"–0.162" diameter; screws are SDS, SDW, USP WS, or TrussLOK-EWP™.
- An additional row of nails is required with depths of 14" or greater.
- When connecting 4-ply members, nail each ply to the other and offset nail rows by 2" from rows in the ply below.

DETAIL SCHEDULE

Beam and header details

- L1** bearing at wood wall
- L2** bearing for door or window header
- L3** beam to beam connection

- L4** bearing at concrete wall
- L5** bearing at wood or steel column
- L6** connection of multiple pieces

Column details

- P1** beam on column cap
- P2** column base
- P3** elevated column base

BEAM AND HEADER BEARINGS

Minimum Bearing Length for Beams and Headers

Beam Depth	Bearing	Span of Header or Beam								
		4'	6'	8'	10'	12'	16'	20'	24'	28'
5½"	End/Int.	2¼" / 4½"	1½" / 3½"	1½" / 3½"	1½" / 3½"	1½" / 3½"				
7¼"	End/Int.	3½" / 6¼"	2½" / 5½"	1¾" / 4¼"	1½" / 3½"	1½" / 3½"	1½" / 3½"			
8⅝"	End/Int.	3¼" / 8"	2¼" / 5½"	1¾" / 4"	1½" / 3½"	1½" / 3½"	1½" / 3½"	1½" / 3½"	1½" / 3½"	
9¼", 9½"	End/Int.			3¾" / 8¾"	3" / 7½"	2½" / 6¼"	1¾" / 4¾"	1½" / 3¾"	1½" / 3½"	1½" / 3½"
11¼", 11⅝"	End/Int.					4" / 9½"	2¾" / 7¼"	2¼" / 5¾"	1¾" / 4¾"	1½" / 4¼"
14"	End/Int.						4" / 9¾"	3" / 8"	2½" / 6½"	2¼" / 5¾"
16"	End/Int.							4" / 10"	3¼" / 8½"	2¾" / 7¼"
18"	End/Int.								4¼" / 10½"	3½" / 9"
20"	End/Int.									4¾" / 11"

- **Minimum bearing length:** 1½" at ends, 3½" at intermediate supports.
- Bearing across full beam width is required.
- Bearing lengths shown are based on bearing stress for TimberStrand® LSL, Microllam® LVL, or Parallam® PSL. If the support member's allowable bearing stress is lower (e.g., when bearing on a flat wood plate), bearing lengths may need to be increased.
- Table assumes maximum allowable uniform load. For other conditions, contact your Weyerhaeuser representative.
- Beams and headers require lateral support at bearing points and along the top (or compression edge) at 24" on-center or closer.
- 1¾"-thick members that are 16" or deeper must be used in multiple-ply units only.

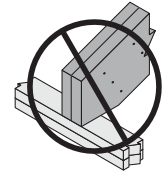

DO NOT overhang seat cuts on beams beyond inside face of support member

Beam Attachment at Bearing

1½" TJ® Rim Board or 1¼" TimberStrand® LSL

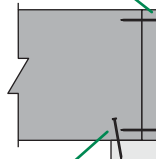

Drive nails at an angle to minimize splitting of plate

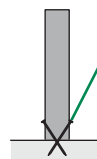

One 10d (0.128" x 3") nail each side of member at bearing, 1½" minimum from end

OUR GUARANTEE



For conditions not shown in this guide, or other assistance, contact your Weyerhaeuser representative or call

1-888-453-8358

CODE EVALUATIONS, See

TJJ® Joists

- ICC ES ESR-1153 ▪ CCMC 13132-R
TimberStrand® LSL
- ICC ES ESR-1387 ▪ CCMC 12627-R
Parallam® PSL
- ICC ES ESR-1387 ▪ CCMC 11161-R
Microllam® LVL
- ICC ES ESR-1387 ▪ CCMC 08675-R
TJ® Rim Board
- ICC ES ESR-1387 ▪ CCRR 0222C

WARNING: Drilling, sawing, sanding or machining wood products generates wood dust. The paint and/or coatings on this product may contain titanium dioxide. Wood dust and titanium dioxide are substances known to the State of California to cause cancer. For more information on Proposition 65, visit wy.com/inform.

PRODUCT STORAGE

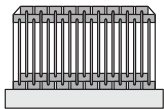

Store and handle joists in vertical orientation.



Have a damaged joist or beam?

File a damage report online for prompt service from your regional technical office. Scan the QR code with your smartphone or go to woodbywy.com/support.

Protect products from sun and water.

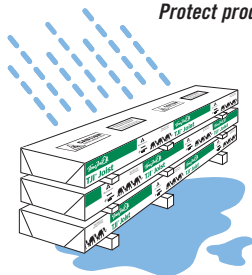

CAUTION: Wrap is slippery when wet or icy.

Align stickers (2x3 or larger) directly over support blocks.

Use support blocks (6x6 or larger) at 10' on-centre to keep products out of mud and water.



woodbywy.com



July 2016 • Reorder TJ-9001

This document supersedes all previous versions. If this is more than one year old, contact your dealer or Weyerhaeuser rep.

▲ Weyerhaeuser, Javelin, Microllam, Parallam, TimberStrand, TJ, TJI, and Trus Joist are registered trademarks and Edge Gold is a trademark of Weyerhaeuser NR. © 2016 Weyerhaeuser NR Company. All rights reserved. Printed in the USA.