

# ROOFING APPLICATION STANDARD (RAS) No. 120 MORTAR AND ADHESIVE SET TILE APPLICATION

## 1. Scope

This application standard covers the procedures for installation of mortar or adhesive set roof tile systems. This standard shall be used in conjunction with the tile manufacturer's Product Approval and RAS 127.

NOTE #1: The following table provides the contractor with the choices available for underlay systems. These systems can only be used on pitches designated in the table below:

## 2. Definitions

For definitions of terms used in this application standard, refer to ASTM 1079 and the *Florida Building Code, Building*.

Roof Pitch	Choice of Underlayment	Plastic or Compatible Roof Cement at Nails Penetrating Underlayment	Reference
2:12 or greater	1. ASTM D 226 Type II #30 or ASTM D 2626 (#43) inorganic base nailed to deck, min ASTM D 249 (#90) organic cap sheet set in Type IV hot asphalt.	Required	3.01 A
	2. Any product approved underlayment system with a mechanically fastened base sheet, and cap sheet set hot, cold, or self adhered.	per Product Approval	3.01 B, C, or D

This Roofing Application Standard covers flat, low and high-profile roof tile, using a minimum 2 in. tile headlap, or design limited headlap as specified in tile manufacturer's Product Approval. Installed on minimum <sup>13</sup>/<sub>32</sub> in. solid decking nailed in compliance with Chapter 23 (High-Velocity Hurricane Zones) of the *Florida Building Code, Building*.

1. Fasteners shall be in compliance with Section 1523 of the *Florida Building Code, Building* (herein referred to as "Approved Fasteners").

**PART I - GENERAL**

1.01

- A. Tiles shall not be installed over wet underlayment where moisture prohibits adhesion of mastic, mortar, or adhesive.

**PART II - MATERIALS**

2.01 Fasteners:

- A. Tile Fasteners:

1. All roof tile nails or fasteners, except those made of copper, Monel, aluminum, or stainless steel, shall be tested for corrosion in compliance with TAS 114 Appendix E, Section 2 (ASTM G 85), for salt spray for 1000 hours. Tile fasteners used in coastal building zones, as defined in Chapter 16 (High-Velocity Hurricane Zones), *Florida Building Code, Building* shall be copper, monel, aluminum, or stainless steel.
2. All roof tile fasteners shall be of sufficient length to penetrate a minimum <sup>1</sup>/<sub>2</sub> in. through the thickness of the deck or batten, whichever is less, or to penetrate into a 1 in., or greater, thickness of lumber not less than 1 in.

- B. Underlayment Fasteners:

- (aa) Nails shall be minimum 12 gage, annular ring shank nails having not less than 20 rings per inch; heads not less than <sup>3</sup>/<sub>8</sub> in. in diameter; and lengths sufficient to penetrate through the plywood panel or wood plank decking not less than <sup>3</sup>/<sub>16</sub> in., or to penetrate into a 1 in., or greater, thickness of lumber not less than 1 in. Nails shall be hot dipped; electro or mechanically galvanized to a thickness sufficient to resist corrosion in compliance with Appendix E of TAS 114. All nails shall have Product Approval. All nail cartons or carbon labels shall be labeled to note compliance with corrosion-resistance requirements.

- (bb) Such fasteners shall be applied through "tin caps" not less than <sup>15</sup>/<sub>8</sub> in. and not more than 2 in. in diameter and of not less than 32 gage (0.010 in.) sheet metal. All tin caps shall have Product Approval.

(cc) Prefabricated fastener systems complying with Section 1517.5, *Florida Building Code, Building* may be used, (provided they have Product Approval).

- B. Cold process modified bitumen roofing mastic - conforming to ASTM D 3019, Type III.
- C. Asphalt - conforming to ASTM D 312, Type IV.

2.04 Adhesive/Sealant:

2.02 Metal Flashing:

A. Structural-bonding adhesive conforming to ASTM 3498.

A. Flashing materials shall comply with the requirements set forth in Chapter 15 (High-Velocity Hurricane Zones) of the *Florida Building Code, Building*.

2.05 Mortar:

A. Materials:

1. Metal accessories for roofs shall be not less than 26 gage galvanized or stainless steel, 16 ounce copper, 0.025 in. thick aluminum, lead sheet with a minimum 2.5 lb/sf or equivalent non-corrosive lead metal alloys or composite materials manufactured for use as roof termination. All composite and nonmetallic flashing materials shall have Product Approval.

1. Roof tile mortar shall either be a premixed unit having an Product Approval and tested in compliance with TAS 123 or a job site mix approved by the building official and in compliance with RAS 113.

2. Metal accessories may be of a manufactured, shop fabricated or field fabricated type, provided the materials and fasteners are in compliance with the minimum requirement of this Code and shall be installed in compliance with methods set forth in RAS 111.

B. Mixes:

- 1. Sand/cement mixes, job mixed or premixed, shall meet ASTM C 270 requirement for Type M mortar (2.25 to 2.5:1 sand to cement ratio).
- 2. Lightweight aggregate/cement mortar must be premixed and bagged.

2.03 Asphaltic Adhesive:

A. Asphalt plastic roof cement - conforming to ASTM D 4586, type II, nonasbestos, nonrunning, heavy body material composed of asphalt and other mineral ingredients.

2.06 Eave Closure—CHOOSE ONE of the following:

- A. Prefabricated EPDM synthetic rubber conforming to ASTM D 1056.
- B. Prefabricated metal eave closure must contain minimum 3/8 in. diameter weepholes, spaced not more than 12 in. apart, flush with the underlayment.

- C. Prefabricated concrete or clay eave closure.
- D. Mortar (color optional) on granular surface underlayments only.
- E. Antiponding drip edge.

2.07 Sheathing Material shall conform to APA rated sheathing, in compliance with Chapter 23 (High-Velocity Hurricane Zones) of the *Florida Building Code, Building*.

- A. Battens-material to be decay resistant species or pressure treated in compliance with AWWA LP-2 or better.
  - 1. Battens shall not be bowed or twisted.
  - 2. Vertical battens shall be a minimum of nominal 1 in. x 4 in., horizontal battens shall be a minimum of nominal 1 in. x 2 in.

Anchor/base sheet end laps shall be a minimum of 6 in. and head laps shall be a minimum of 4 in. Over installed anchor/base sheet, apply one layer of mineral surfaced cap sheet ASTM D 249 in full 25 lb./sq, ± 15 percent mopping of asphalt. Asphalt shall be applied uniformly so that felts do not touch felts. End laps shall be a minimum of 6 in.; head laps shall be a minimum of 3 in. and back nailed 12 in. on center with approved nails through tincaps.

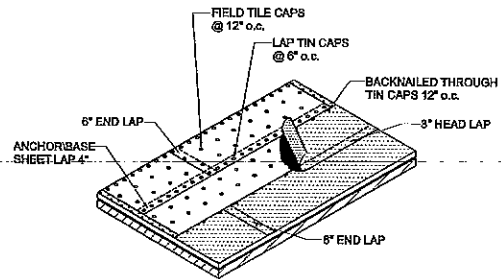

**PART III - EXECUTION**

3.01 Underlayment Applications - CHOOSE ONE of the following:

NOTE #3: Anchor/base sheet shall be a minimum of two plies in the valleys. Cap-sheets for mortar set systems shall be mineral surfaced. A No. 30 or No. 43 can be used as a dry-in prior to installing the underlayment with this system

- A. Hot Mop 30/90, Hot Mop 43/90 (See Drawing 1). A No. 30 or No 43 anchor/base sheet ASTM D 226, Type II, or ASTM D 2626 shall be mechanically attached to the wood deck with approved fasteners spaced in a 12 in. grid staggered in two rows in the field, and 6 in. on center at the laps. Extend anchor/base sheet a minimum of 4 in. up vertical surfaces. An-

**DRAWING 1  
TYPICAL 30/90 HOT MAP**

NOTE #3: The above system may be upgraded by hot mopping an interply of ASTM listed fiberglass or perforated organic felt to the anchor sheet before applying the cap sheet. Asphalt application shall be per above specifications.

- B. Hot applied Product Approved underlayment system (see Drawing 1). An anchor/base sheet shall be mechanically attached to the wood deck (unless directed otherwise by Product Approval) with approved fasteners spaced in a 12 in. grid staggered in two rows in the field, and 6 in. on center at the laps. Anchor/base sheet end laps shall be a minimum of

6 in. and head laps shall be a minimum of 4 in. Over installed anchor/base sheet, apply one layer of cap sheet in a full 25#/sq. ±15 percent mopping of asphalt. Asphalt shall be applied uniformly so that felts do not touch felts. End laps shall be a minimum of 6 in.; head laps shall be a minimum of 3 in. and backnailed 12 in. on center through fincaps.

underlayment in compliance with the self-adhered underlayment manufacturers' Approval/ Requirements.

E. Self-Adhered Underlayment (single ply). A single ply underlayment system utilizing any Product approved self-adhered underlayment. The roof cover is terminated at approved metal flashings. Apply one layer of any self-adhered underlayment in compliance with the underlayment manufacturers' approved/requirements.

C. Cold applied Product approved underlayment system (see Drawing 1). An anchor /base sheet shall be mechanically attached to the wood deck with approved fasteners spaced in a 12 in. grid staggered in two rows in the field and 6 in. on center at the laps or as specified in the underlayment manufacturers Product Approval. Anchor/base sheet end laps shall be a minimum of 6 in. and head laps shall be a minimum of 4 in. Over anchor/base sheet, apply one layer of cap sheet in a continuous layer of cold process adhesive at the rate of 1.5 gal/sq. or at the rate if so stated in the Product Approval. Adhesive shall be applied uniformly with a squeegee or knotted brush so that felts do not touch felts. Cap sheet side laps shall be a minimum of 6 in.; head laps shall be a minimum of 3 in. and backnailed 12 in. on center.

3.02 Drip Edge Metal - CHOOSE ONE of the following:

NOTE #5: All exposed planes of drip edge to receive asphalt shall be primed with ASTM D 41 Asphalt primer.

A. 2-ply underlayment systems.

1. Drip edge metal shall be installed over anchor/base sheet, fastened 4 in. on center with approved 1 1/4 in. roofing nails or approved fasteners. All joints shall be lapped a minimum of 4 in. ensuring water shedding capabilities and sealed with plastic roof cement.

D. Product Approved Anchor/Base Sheet / Self - Adhered Underlayment system. The roof cover is terminated at approved metal flashings. Any approved anchor /base sheet as listed in the Product Approval shall be mechanically attached to the wood deck with approved fasteners spaced in a 12 in. grid staggered in two rows in the field and 6 in. on center at the laps or as specified in the underlayment manufacturers Product Approval. Anchor/base sheet end laps shall be a minimum of 6 in. and head laps shall be a minimum of 4 in. Over anchor /base sheet, apply one layer of any Product approved, self-adhered

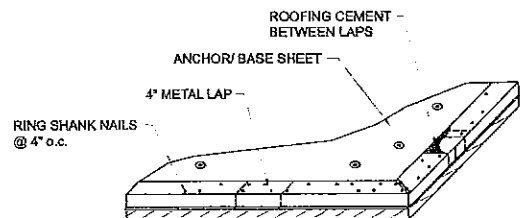

DRAWING 2  
DRIP EDGE INSTALLATION

- B. When drip edge metal shall be installed at eaves and gables over a two ply underlayment system: The metal profile shall be placed in a minimum <sup>3</sup>/<sub>16</sub> in. bead of continuous ASTM D 4586 plastic roof cement and fastened 4 in. o.c. with approved 1 <sup>1</sup>/<sub>4</sub> in. roofing nails or approved fasteners. All bonding surfaces shall be fully primed with ASTM D 41 primer. All metal joints shall be lapped a minimum of 4 in. ensuring water shedding capabilities and sealed with approved plastic roof cement. The metal profile and cap sheet shall be joined with a two ply application of cotton or fiberglass fabric reinforcement, both set in a full bed of approved plastic roof cement. As an alternate, the metal may be stripped in with a 6" strip of torch, hot asphalt or cold adhesive polyester reinforced modified bitumen. Joints shall be feathered with cold adhesive, hot asphalt or a torch to enhance water flow across the "backlap."

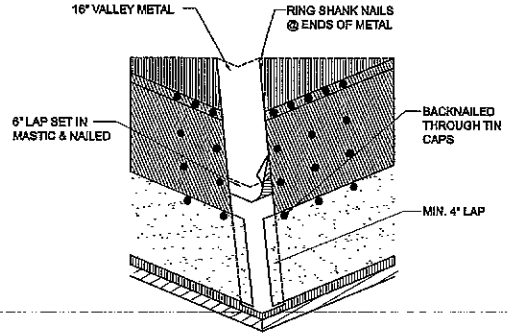

DRAWING 3  
TYPICAL VALLEY INSTALLATION

- B. Preformed or roll metal without returns 16 in. wide, shall be installed on top of the cap sheet, fully embedded in hot asphalt or plastic roof cement. All joints shall be water shedding and lapped a minimum of 6 in. in a bed of plastic roof cement. Strips of cap sheet, not less than 8 in. wide shall be lapped over the metal edge, not less than 4 in. and sealed with hot asphalt or plastic roof cement and membrane. An optional #90 sweat sheet 36 in. wide may be applied prior to the installation of the cap sheet and valley metal. (see Drawing 4).

3.03 Valleys - CHOOSE ONE of the following:

NOTE #6: All metal surfaces to receive hot asphalt shall be primed with ASTM D 41 asphalt primer.

- A. Preformed or roll metal without returns 16" wide shall be placed over the anchor/base sheet in the valley and shall be fastened with 12 ga. corrosion-resistant roof nails, or other approved fasteners of compatible metals near the outside edge of the valley metal. All joints shall be water shedding and lapped a minimum of 6 in. in a bed of plastic roof cement. The cap sheet shall be bonded to the metal with asphaltic adhesive (see Drawing 3).

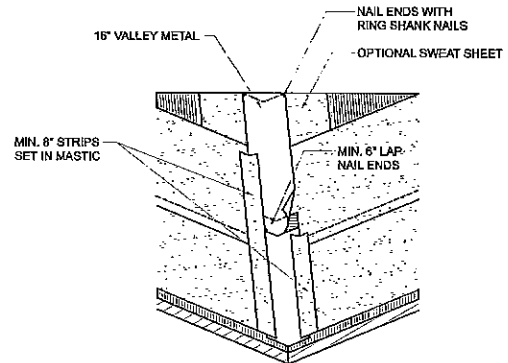

DRAWING 4  
VALLEY METAL STRIPPED IN

3.04 Flashing and Counter Flashings at Wall Abutments

NOTE #7: In no case shall top of vertical flashing be less than 2 in. above tile surface.

A. Two-Ply System - (Choose 1 or 2) (see Drawings 5, 6 and 7).

1. Install minimum 4 in. x 5 in. "L" metal flush to base of walls with 4 in. flange on the anchor/base sheet and fasten within 1 in. of outside edge. Lap joints 4 in. ensuring water shedding capabilities and apply approved plastic roof cement between laps. Fasten the vertical and horizontal flange of metal within 1 in. of out side edge a minimum of 6 in. on center. The cap sheet shall be bonded to the metal with asphaltic adhesive.

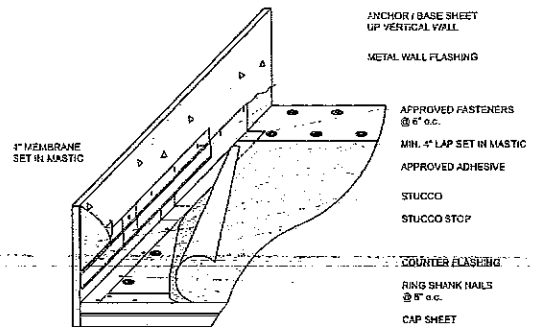

DRAWING 6  
WALL FLASHING DETAIL  
(STUCCO STOP DETAIL)

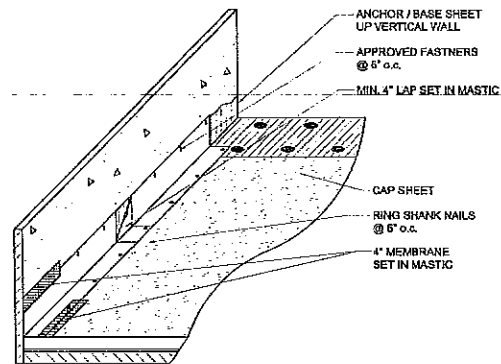

DRAWING 7  
WALL FLASHING DETAIL  
(WALL FLASHING OVER CAP SHEET)

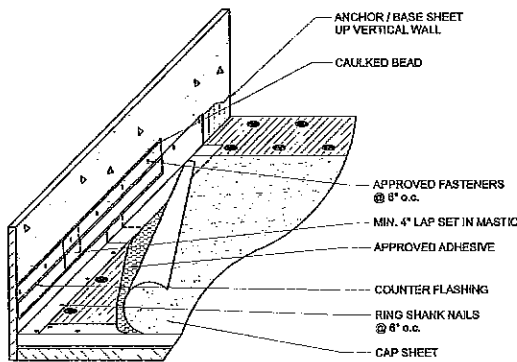

DRAWING 5  
WALL FLASHING DETAIL  
(COUNTER FLASHING WITH CAULKED BEAD)

2. Install minimum 4 in. x 5 in. "L" metal on the top ply and fastened 6 in. on center with 12 ga. corrosion resistant roof nails, or other approved fasteners of compatible metals within 1 in. of outside edge of the metal. All joints shall be lapped a minimum of 4 in. ensuring water shedding capabilities and apply plastic cement

between laps. Cap sheet shall be joined with a bed of plastic roof cement and a 4 in. strip of asphalt saturated cotton or fiberglass fabric. The fabric shall be fully embedded in the plastic roofing cement.

- 3. Seal along top edge within 1 in. of vertical flange, covering all fastener penetrations with approved plastic roof cement and membrane.
- 4. When installing optional counter flashing, lap top flange of base flashing minimum 3 in. Fasten metal within 1 in. of the outside edge a minimum of 6 in. on center or set into reglets (secured properly) and thoroughly caulk. Lap joints minimum 4 in. ensuring water shedding capabilities and apply approved plastic roof cement/sealant between laps.

3.06 Pipes, Stacks, Vents, etc. (see Drawings 8 & 9).

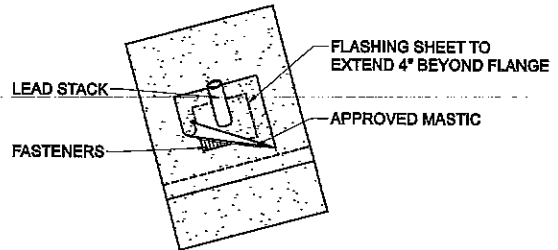

DRAWING 8

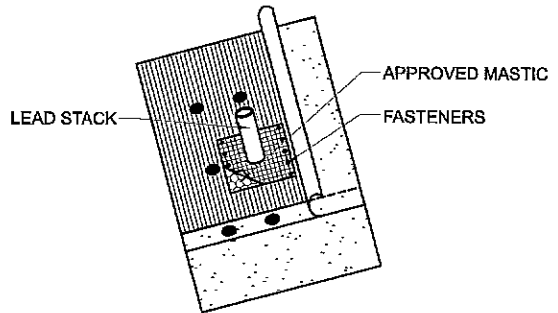

DRAWING 9

3.05 Standard Curb Mounted Skylights, Chimneys, etc. (see Section 3.04 above).

- A. Curbs shall be a minimum 2 in. x 6 in., and a minimum 2 in. above uppermost adjacent finished tile surface.
- B. Follow instructions in 3.04 A or B in this System.

NOTE #8: For self-curbing or prefabricated skylights, installation shall meet Section 3.04B above and skylight manufacturer's Product Approval. For turbines and other Product approved accessories refer to the accessories manufacturer's Product Approval.

A. Apply approved plastic roof cement around base of protrusion and on the bottom side of metal flanges sealing unit base flashing to the underlayment.

B. Nail all sides within 1 in. of outside edge of base flashing 6 in. on center. Make certain base is flush to deck.



NOTE #9: If pipes, vents and/or stacks are installed after finished cap sheet has been applied, follow instructions in 3.06 A & B. Cap sheet and metal flange shall be stripped in with at least the same cap sheet felt in use on this system. Strip-ping must extend at least 4 in. beyond flange in all directions. For turbines and other Product approved accessories refer to the Product Approval.

over fascia/starter strip. Fasten top edge of flange onto roof and fasten eave edge to raised fascia detail with approved fasteners 4 in. on center.

3.07 Tile Installation:

A. Eave treatment - CHOOSE ONE of the following:

1. Prefabricated EPDM synthetic rubber - Install closure strip along eave. Fasten each piece at 12 in. on center (see Drawing 10).
2. Metal Eave Closure - Install closure strip along eave. Fasten a minimum 12 in. on center. If metal is inclusive of drip edge, fasten 4 in. on center (see Drawing 11).
3. Raised Fascia/Wood Starter Strip when using a 3/4 in. raised fascia, a nominal 2 in. x 2 in. wood starter strip must be installed behind fascia.
  - (aa) Install fascia board approximately 1 1/2 in. above roof deck or a nominal 2 in. x 2 in. wood starter strip at roof edge (see Drawing 12).
  - (bb) Install 8 in. tapered cant strip at eave behind fascia and/or starter strip to support metal flashing. Install a minimum 8 in. wide antiponding metal flashing to ensure positive drainage

4. Prefabricated concrete or clay eave closure - fastened per manufacturer's specifications, such fasteners to be approved and sealed with plastic roof cement.

NOTE #10: All fastener penetrations shall be sealed. Mortar eave closures shall only be used with granular surface underlayments.

6. Mortar Application - Install mortar to elevate eave edge.

(aa) Apply mortar along the eave edge, applying enough mortar to elevate the eave end of the tile to be on profile with the remaining roof tile.

(bb) Point and smooth finish flush to eave line.

(cc) Apply minimum 3/8 in. weep hole flush with the roof underlayment at spacing of not less than one weephole per tile.

NOTE #11: Tile shall be attached to resist the design pressures for the building. See Chapter 16 (High-Velocity Hurricane Zones) of the Florida Building Code, Building and RAS 127.

See tile manufacturer's Product Approval for attachment resistance values, which must exceed the required calculated design pressures of the structure.

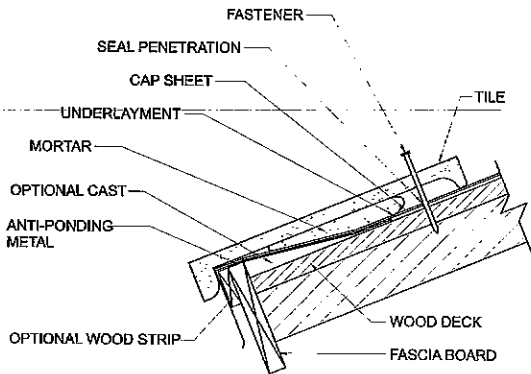

**DRAWING 10**  
**EAVE TILE DETAIL**  
**(EPDM EAVE ENCLOSURE)**

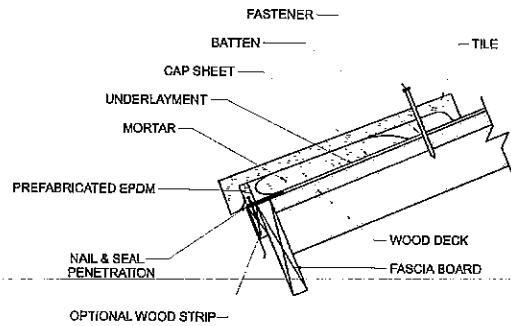

**DRAWING 12**  
**EAVE TILE DETAIL**  
**(ANTIPONDING METAL)**

A. Mortar/Adhesive Application:  
Low, High and Flat Profile Tile  
(see Drawings 13).

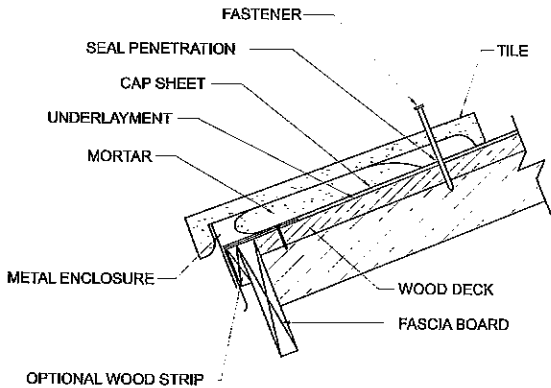

**DRAWING 11**  
**EAVE TILE DETAIL**  
**(METAL EAVE ENCLOSURE)**

1. Set tile in a bed of approved mortar/adhesive. Apply 10 in. minimum length trowel of mortar or required amount of adhesive vertically under pan. For flat tile place mortar/adhesive vertically adjacent to the overlock of the tile being installed. Do not apply mortar under headlug of tile, or onto the underlock of adjacent tile. (Unless otherwise specified in adhesive's manufacturers Product Approval)
2. Use half starter/finisher tile when provided or cut/break tile for proper staggering of tile courses when using the staggered/cross bond method of installation.

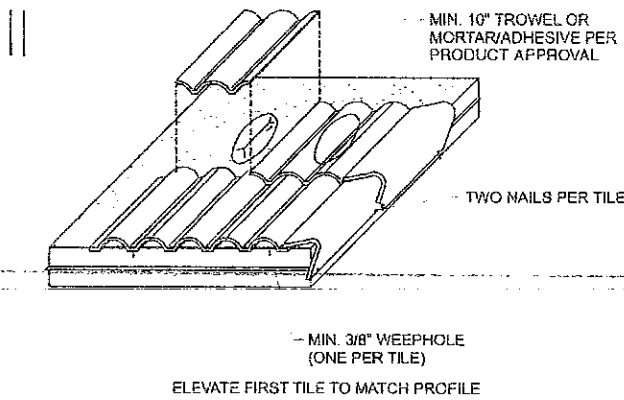

**DRAWING 13  
MORTAR SET TILE**

3. Set tile in stepped course fashion or in a horizontal and/or vertical fashion when utilizing straight bond method.
4. Lay succeeding course of field tile in same manner.
5. Cut/break field tile to form straight edge at center of hip/ridge.

NOTE #12: Mortar or adhesive set tile shall be applied at inclines of 2:12 and greater. For pitches of 6 in.: 12 in. up to and including 7 in.: 12 in. nail every third tile in every fifth course in addition to mortar or adhesive. For pitches above 7 in.:12 in. nail every tile in addition to mortar or adhesive. Apply approved flashing cement to seal all nail penetrations. Fastening requirements at slope of 7:12 or less for Two-Piece Barrel application applies to pan tiles only. No mortar or adhesive products shall be applied in a manner which prevents drainage of water under tiles.

**B. Two-Piece Barrel Tile Mortar or Adhesive Application (see Drawing #14):**

1. Apply 10 in. mason's trowel of mortar or required amount of adhesive in accordance with the tile system Product Approval vertically over chalk line and under center of each pan with narrow end facing down roof.

2. Place bed of mortar or required amount of adhesive in accordance with the tile system Product Approval along inside edges of pans and set covers with wide end facing down roof.

3. Point mortar to form acceptable straight-edge finish ensuring contact along edges. Cosmetic use of mortar is acceptable for use with adhesive set tiles.

4. Lay succeeding courses of field tile in same manner. Bed of mortar or adhesive should make contact with head of lower course of tile and underside of tile being set.

5. Cut/break field tile to form straight edge at center of hip/ridge.

**3.08 Valleys - CHOOSE ONE of the following:**

NOTE #13: It may be necessary to remove the lugs from the field tile at walls and valley flashings for proper positioning of cut field tiles.

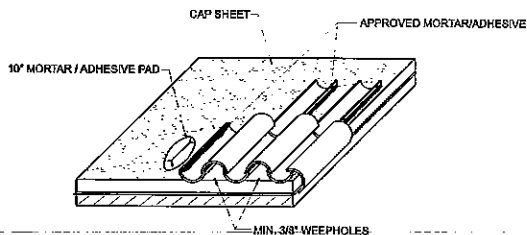

**DRAWING 14  
BARREL TILE INSTALLATION**

**A. Standard Roll Valley**

1. Closed valley - Miter tile to meet at center of valley.
2. Open Valley - Chalk a line a minimum 2 in. on both sides of the valley center. Place bed of mortar along outside edge of chalk lines. Miter tile to form straight border and point to match tile surface.

**B. Preformed Metal Without Returns**

1. Closed valley - Miter tile to form straight border on either side of water diverter.
2. Open Valley - Miter tile to form straight border on either side of two water diverters (see Drawing 15).

**3.09 Hip Starter - CHOOSE ONE of the following:**

- A. Prefabricated hip starter.**

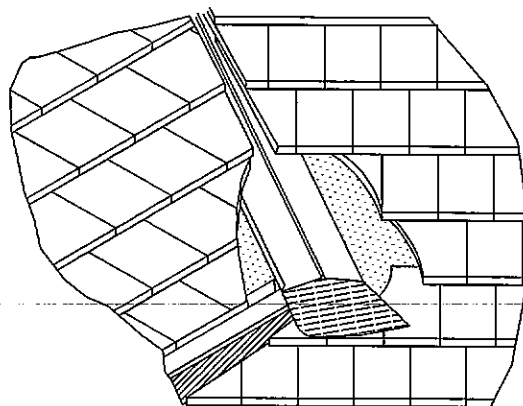

**DRAWING 15  
NAIL-ON VALLEY SYSTEM  
VALLEY METAL OVER TILE**

1. Miter tile as hip starter to match eave lines.

**B. Use standard hip tiles as starter.**

**3.10 Hip and Ridge Installation - CHOOSE ONE of the following:**

- A.** Set hip and ridge tile in a continuous bed of mortar, lapping tile a minimum 2 in. Ensure bed of mortar does not protrude in center of hip or ridge junction. Approximately 1 in. of field tile shall extend beyond bed of mortar.

**OR**

- B.** Mechanically fasten hip and ridge tiles to nailer board shall be optional on roof slopes of 2:12 to 7:12, and shall be required on roof slope greater than 7:12.

1. Wood nailers shall be required and attached in compliance with Chapter 16 (High-Velocity Hurricane Zones) of the *Florida Building Code, Building*. (see Drawing

16 - Details 1, 2, 3 and 4 are also accepted methods of installing Hip and Ridge Nailer Boards).

- 2. Wood nailer boards shall be secured with galvanized steel straps of a minimum thickness of 1/8 in. by 1 1/4 in. wide. The galvanized steel straps shall be installed at a maximum spacing of 12 in. o.c. along the length of the ridge nailer boards. Steel straps shall be bent to fit over the ridge nailer boards, and shall be secured to the sheathing with a minimum of six #6-#8 corrosion resistant screws per strap, at a maximum spacing of 4 in. o.c.

DETAIL 1

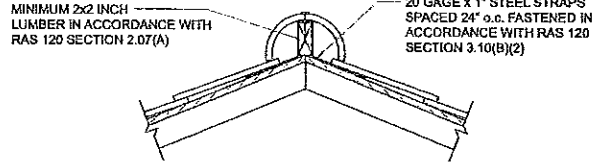

DETAIL 2

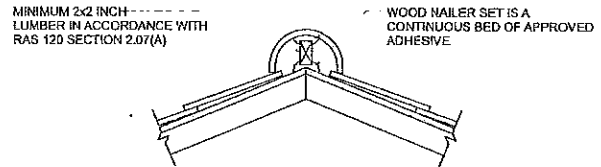

HIP OR RIDGE TILE

2x6 OR 2x8 HIP OR RIDGE NAILER PRESSURE TREATED

1/8"x 1-1/4" GALV. METAL STRAP BENT TO FIT SPACED AT 12" CENTER TO CENTER

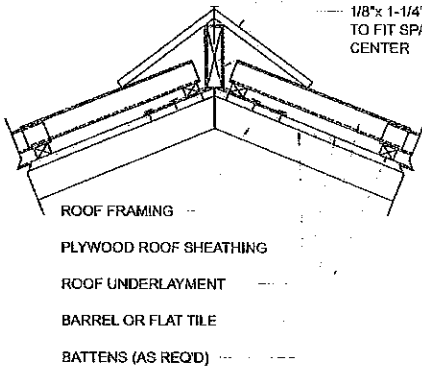

HIP OR RIDGE TILE NAILING DETAIL

DRAWING 16

DETAIL 3

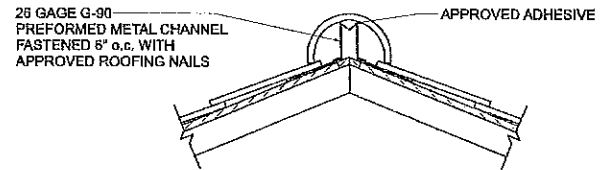

DETAIL 4

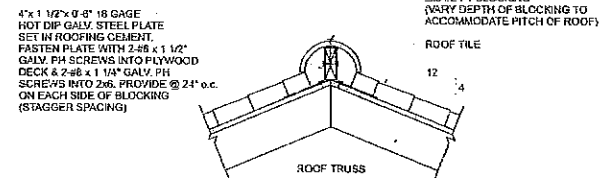

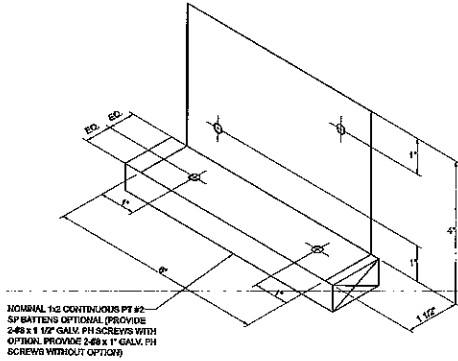

1/2" JOURNAL 1/2" CONTINUOUS PT #2  
 SP BATTENS OPTIONAL (PROVIDE  
 2#8 x 1 1/2" GALV. PH SCREWS WITH  
 OPTIONAL BRACING 2#8 x 1" GALV. PH  
 SCREWS WITHOUT OPTION)

SHEET PLATE DETAIL  
**DETAIL 5**  
**SHEET PLATE DETAIL**

- A. Cut tile to fit approximately 1/2 in. to base of walls. Fill void with mortar and point to finish.

3.13 Plumbing Stacks

- A. Cut tiles to fit close to plumbing stack. Fill void with mortar and point to finish.

3.11 Rake/Gable - CHOOSE ONE of the following:

A. Rake/Gable Tile:

1. Install first rake tile the exposed length of first course of field tile with factory finish of rake tile towards the eave.
2. Fasten each rake tile with a minimum of two 10D nails of sufficient length to penetrate the framing a minimum of 3/4 in.
3. Abut each succeeding rake tile to the nose of the field tile above and maintain a constant headlap.

B. Mortar Finish:

1. Place mortar bed along roof edge.
2. Point smooth to a straight edge finish.

3.12 Wall Abutments