

Preferred door solutions.[®]

COOKSON

*Defender Series Door
Installation Instructions*



SHEETS 1-27

Section 1 – Table of Contents





Section 2 – Safety Check List	2
Section 3 – Freight Receiving	3
Section 4 – Pre-installation	4
Section 5 – Guides	5
Face-Of-Wall	5
Section 6 – Barrel and Brackets	8
Preparation	8
Hoisting and Installing Barrel Assembly	9
Section 7 – Motor Operator Installation	12
Section 8 – Curtain Installation	13
Section 9 – Spring Release Setup	14
Applying Spring Turns	14
Section 10 – Lintel Seal	15
▪ "Z" Shaped Seal	15
▪ "L" Shaped Seal	16
Section 11 – Hood Support Installation	17
Section 12 – Hood, Fascia, and Covers	19
Hood and Fascia	19
Hood Splice	20
Covers	21
Section 13 – Torque Specifications	22
Section 14 – Maintenance Schedule	23
Operator Troubleshooting	25
Appendix A – Chain Sprocket Adjuster	26

Section 2 – Safety Check List

Rolling doors are large, movable objects. They move with the help of electric motors or manual operators (chain, crank, push up, etc), and most have springs under high tension. These items and their components can cause injury. In order to avoid injury to yourself and others, please follow the instructions in this manual.

- **Review the potential hazards and preventative measures listed below:**

Table 2.1 - Potential Hazards and Preventative Measures

Potential Hazard	Preventative Measure
 <p style="text-align: center;">⚠ DANGER Pinned or crushed by closing door.</p>	<ul style="list-style-type: none"> • Keep yourself and others clear of opening while door is in motion. • Do not allow children to play near or operate door. • Do not operate if door becomes jammed or broken.
 <p style="text-align: center;">⚠ WARNING Struck by adjusting wheel bar while applying spring turns.</p>	<ul style="list-style-type: none"> • Be sure bar is adequate in strength and long enough to allow installer to apply the necessary torque. • Make sure bar is fully seated into the adjusting wheel slot before applying pressure. • Use two bars while applying turns to the adjusting wheel.
 <p style="text-align: center;">⚠ WARNING Electrical shock.</p>	<ul style="list-style-type: none"> • Make sure electrical operator is properly grounded. • Turn off source power completely prior to servicing the motor. • Make sure wires are clear of any moving or potentially moving parts. • Avoid pinching wires when installing the motor cover.
 <p style="text-align: center;">⚠ WARNING Pinched by moving components.</p>	<ul style="list-style-type: none"> • Make sure the motor is turned off and unplugged before working with moving parts such as roller chain and sprockets, drop-out mechanisms, adjusting wheels, etc. • Locate the possible pinch-points of the unit (Drive chain, coil area, bottom bar, etc.) Do not operate the door while someone is near these areas.

- **Check the following during installation and before leaving the job site:**
 - a. If the unit has tension springs, be sure the proper amount of tension is applied to the torsion springs, in order to properly counterbalance the weight of the curtain.
 - b. Securely fasten the tension adjusting wheel in place with the appropriate hardware provided.
 - c. Check that the keys and/or cotter pins have been set in place and fit properly at all sprockets or gears.
 - d. Check that the setscrews in each sprocket or gear (one over the key and one offset from the key) have been tightened properly.
 - e. Check all fasteners holding the unit to the building structures.
 - f. Check all fasteners used to assemble the components of the unit together.
 - g. Instruct owner or representative in the proper method of operating the door.

Section 3 – Freight Receiving

- **Upon delivery, check condition of components for damage.**
- **If damage occurred in transit, the installation should not proceed without authorization.**

NOTICE

If the installation proceeds, neither the carrier nor the manufacturer will assume responsibility for replacing the damaged material.

- **If the installation is stopped due to damage, do the following:**
 1. Take pictures of the damage.
 2. Do not move material from point of delivery to other premises once the damaged components are discovered.
 3. Do not unpack, if the damage is visible prior to removing packaging, until an inspection is made.
 4. If the damage is found while removing contents from packaging, the packaging material must be saved until inspection is made.
 5. Container and packaging should be retained by consignee until inspection is made.
 6. Have components inspected by carrier's representative within 15 days from date of delivery.
 7. Consignee must obtain a copy of the Inspection Report.
- **Returning damaged components:**
 1. Obtain permission from carrier to return.
 2. Route the return shipment via the identical carrier(s) involved in the original shipment.
 3. Notify the manufacturer when shipment is returned to manufacture plant.
- **Verify that all components have arrived. Look for the following:**
 1. Job construction drawings featuring different views (elevation, section, plan, etc.)
 2. (2) Guide assemblies; check for guide weathering if included in order
 3. Curtain & Barrel assembly
 4. Curtain slats & Bottom Bar (if required)
 5. (2) Bracket assemblies
 6. Operator; if not attached to bracket
 7. Operator cover; may not be included in order
 8. Adjusting wheel; if the barrel assembly contains springs
 9. Hood and hood supports; may not be included in order
 10. Hardware
 11. Misc. items (Reelite, lintel seal, hood baffle, etc.)
 12. Verify material/finish/color of components matches what is listed on the job construction drawings and/or what was ordered.
- **If the delivery is incomplete:**
 1. Make note on delivery receipt.
 2. Note should be verified by driver's signature.
 3. Notify carrier and manufacturer.

Section 4 – Pre-installation

- **Read entire instruction manual thoroughly. The manufacturer will not be held responsible for any charges incurred due to improperly installed components.**
 - a. Only trained door systems technicians should perform installation, maintenance, etc.
 - b. Each unit comes with an individual item number. If the job contains multiple units, be sure to locate all the components for each item and separate each.

⚠ WARNING

Do not interchange parts from one door to another.

- c. Find the job construction drawings for the unit being installed and check the dimensions of the opening against those on the drawings. See **Figure 4.1** below.
 - d. If the opening dimensions differ from those on the drawings, **do not proceed**, check with distributor/manufacturer to be sure the correct door is being installed.
 - e. Check the jambs of the opening for plumb. Check the head/lintel and floor for level.
- **Work Area:**
 - a. The key to a smooth installation is a clean and well-prepared work environment. Once the components have been inspected and the job construction drawings have been reviewed; lay out the components in the order of installation.
 - b. The opening for the door should be cleaned and inspected for rough surfaces and construction debris.
 - c. Lastly the mounting hardware supplied with the door should correspond with the surface and construction features of the opening.
 - d. The basic assembly sequence is as follows: guides, curtain/barrel/bracket assembly, motor operator (if applicable), bellmouth, weather stripping, hood, and operator/adjustor/idler covers.

Figure 4.1 - Opening Dimensions and Designations

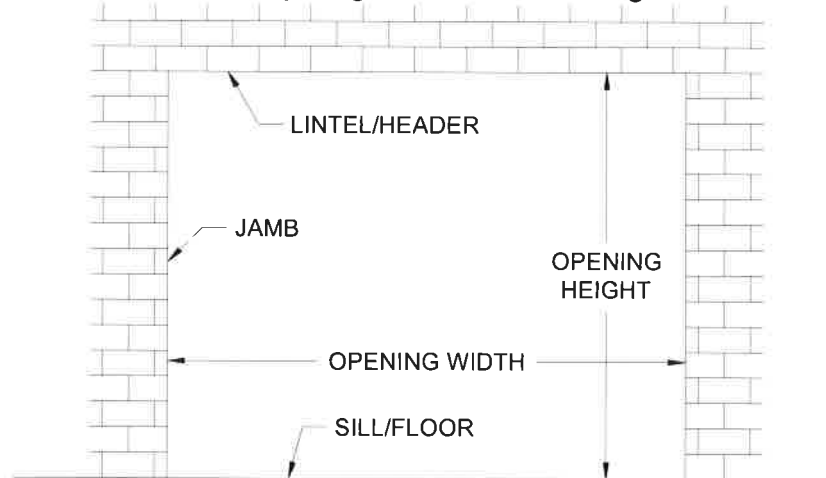

Section 5 – Guides

▪ Face of Wall Units (Figures 5.1 - 5.2):

Note: Determine which guide assemblies the unit has from the job construction drawings and compare to the diagrams below.¹

Figure 5.1 - Face of Wall “Z” Guide

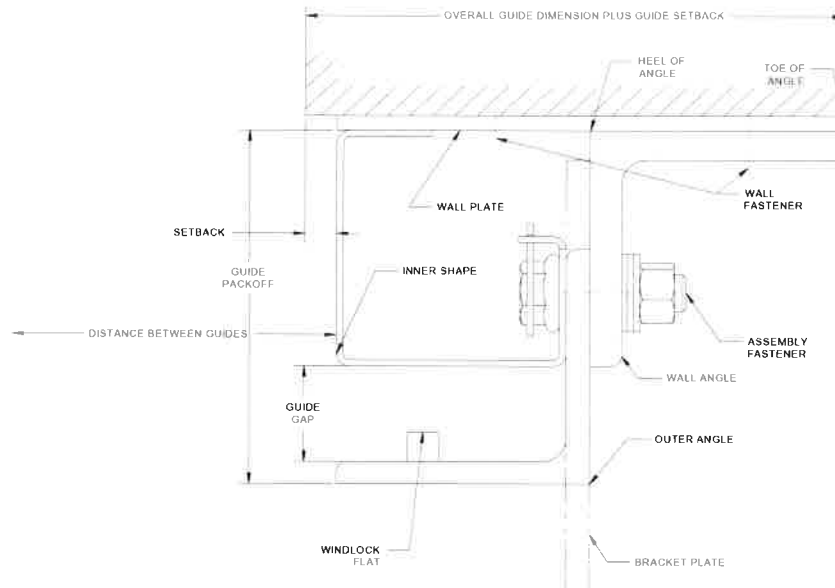
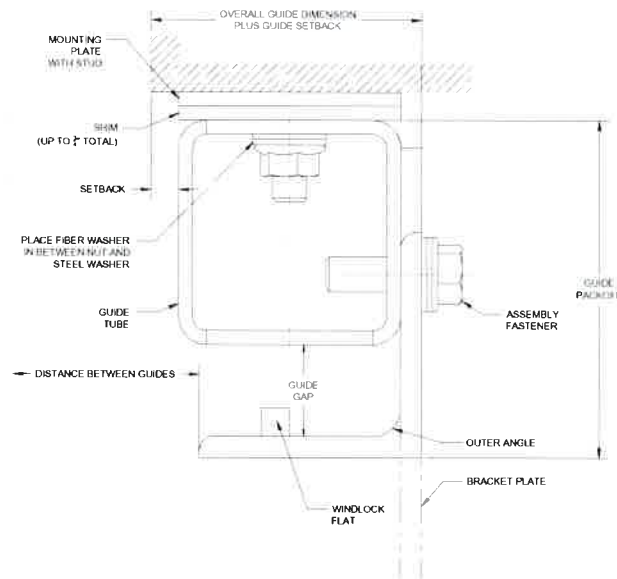

Figure 5.2 – Face of Wall Tube Guide



1. Disassemble all components from the guides.
2. See guide assembly **Figures 5.1 - 5.2**. See the job construction drawings for the dimensions

¹ The guide assembly may differ from the right to left hand side of the unit. In these cases, follow the directions for each particular guide assembly, as well as the job construction drawings provided with the unit.

Section 5 – Guides

- i. For “Z” guides, measure the distance from the opening/jamb to the toe of the wall angle/wall plate. This distance is referred to as the “*Overall Guide Dimension plus Guide Setback*”.
 - ii. For Tube guides, measure the distance from the opening/jamb to the back of the guide tube. This distance would be the “*Overall Guide Dimension plus Guide Setback minus Outer Angle Thickness*”..
3. Place mark on the floor at measured location. Check the distance between these marks and compare with the job construction drawing.

NOTICE

If the measurement does not equal the dimensions on the job construction drawings, **STOP**. Check the guide dimensions against those on the job construction drawings to be sure the correct guides are being installed. If so, repeat previous step and re-check.

4. Scribe a plumb line on the wall from the marks on the floor.
5. Place the tube or wall angle/wall plate against the scribed line, check the top of the guide for level, and mark the location of the wall fastener mounting holes.

Note: For fire doors, mark the holes at the top of the wall fastener slot to allow for upward expansion of the guides.

6. For Zee Guides:
 - i. If the guide is attached to the wall with fasteners, drill mounting holes for the wall fasteners and fasten the wall angle/wall plate with the hardware provided. Check the job construction drawings for the wall fastener required. Tighten the wall fasteners to the recommended installation torque in *Torque Specification Tables* in **Section 13**.
 - ii. If the guide is attached to the wall by welding, see the job construction drawings for details on weld location, type, pitch, size, etc.¹
7. For Tube Guides
 - i. If the guide is attached by welding to an uneven surface, such as embedment plates, mark the location of the slots in the tube, and weld the provided mounting plates to the structure per the details called out on the job construction drawings; weld location, type, pitch, size, etc. Provided shims can then be place between the mounting plate and the tube so that the tube is mounted plumb. The tube should be attached to the mounting plate using the provided hardware. Seal between the tube and wall per job requirements.
 - ii. If the guide is attached by welding to a plumb and flush surface, weld the tube to the structure per the details shown on the job construction drawings; weld location, type, pitch, size, etc.
 - iii. If the guide is attached with fasteners, drill mounting holes for the wall fasteners and fasten the tube with the hardware provided. Check the job construction drawings for the wall fastener required. Tighten the wall fasteners to the recommended installation torque in *Torque Specification Tables* in **Section 13**.
8. Reassemble guides as shown, leaving the removable bellmouth off of each side for installation of the curtain.
9. Adjust the guide gap if necessary. Guide gap is **critical** and must be verified. Check the job construction drawing to determine what guide gap is required for the unit.
10. Preload the assembly fasteners per the torque recommendations in the *Torque Specification Tables* in **Section 13**.

¹ Minimum recommended weld rod: AWS A5.1, Grade E-70.

Section 5 – Guides

11. If guide seal is provided, fasten it to the guide at this time per the guide detail on the job construction drawings.

Section 6 – Barrel and Brackets

Note: Check to see if a hood support will be required. If so, refer to the “**Hood Support Installation**” section before proceeding to the barrel and brackets.

1. Refer to the job construction drawings to determine the “coil side” of the opening, or the side of the opening on which the coil is to be installed. Then determine which jamb wall is your “operator side”, or side on which the operator is to be installed. The following instructions refer to these directional cues.
2. Unpack the curtain/barrel assembly.
3. Position the curtain/barrel assembly on the coil side of the opening, with the end marked “operator” towards the “operator side” of the opening. In order to alleviate the bracket installation, place the curtain/barrel assembly on blocks or spacers such that it is elevated off the ground.

Note: Choose sufficiently sized blocks. The curtain/barrel assembly should be elevated off the ground enough that the brackets can be installed without contacting the floor.

4. Typically the adjusting wheel is not shipped attached to the barrel. However, if the adjusting wheel is attached to the barrel, remove by loosening the bolt or set screws that secure the adjusting wheel to the barrel and sliding the wheel off the inner shaft. See **Figure 6.1**.

Figure 6.1 – Removal of adjustor from barrel assembly

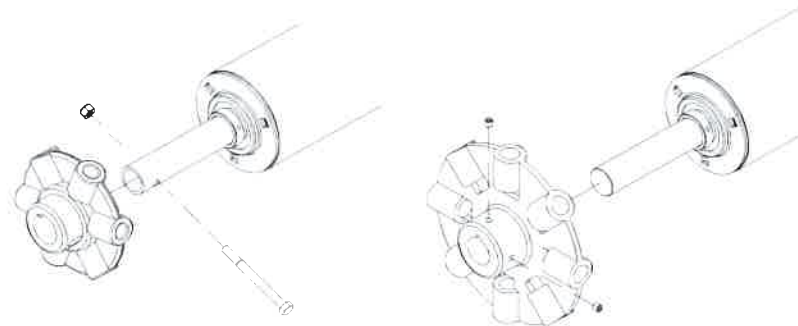

Section 6 – Barrel and Brackets

5. Locate the brackets. Determine the “operator” and “adjustor” brackets by referring to **Figure 6.2**. The “operator” bracket may vary significantly based on the operation of the door. The “adjustor” bracket will contain a label with spring adjustment instructions.
6. Remove the adjusting wheel if you haven't previously it, and slide the adjustor bracket over the inner shaft of the barrel assembly. The hood clip angles should be facing inwards and the dropout pawl should be facing outwards. Install the adjusting wheel (see **Figure 6.1**).
7. The operator bracket is shipped with a temporary plug holding the sprocket(s) and spacer washers in place on the bracket. Remove the plug and the bag of hardware attached to it, taking care not to lose the spacer washers positioned between the sprockets. Do not tighten the set screws in the bearing at this point. You may need to adjust the position when attaching to the guides.
8. Align the bearing, sprocket(s) and spacer washers as shown below, and slide the assembly over the gear end until the inside face of the bracket is approximately 3 inches (4 inches for 8” shafts and larger) from the edge of the outer shaft. It is recommended that you install the keys, located in the bag of hardware you removed with the temporary plug, into each sprocket at this stage. Do not tighten the set screws at this point.

Note: Do not install the operator until the barrel and bracket assembly is hoisted into position and securely fastened to the guides. Installing the operator at this stage will cause the assembly to be lopsided and cumbersome, making it difficult and potentially dangerous to hoist into position.

Figure 6.2 – Brackets and Barrel prior to installation (Curtain not shown for clarity)

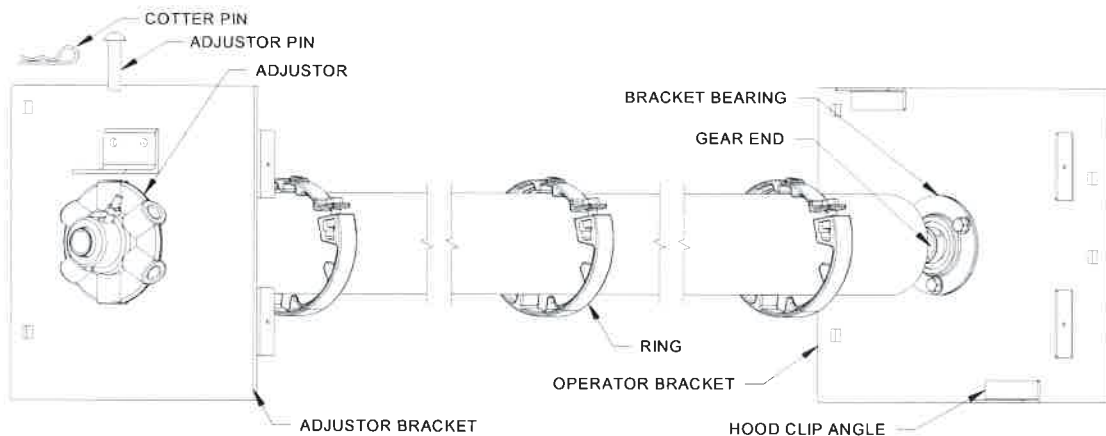

▪ Hoisting and Installing Barrel Assembly

1. The following methods can be used for hoisting them into place:
 - **Crane Hoisting:** Place a sling or lifting agent under the barrel assembly at the “lift point” provided on the barrel, see **Figure 6.1**.
 - **Forklift Hoisting:** Space the forks evenly under the “lift point” provided on the barrel, see **Figure 6.1**. Ensure that the barrel assembly is positioned close enough to the tips of the forks that the fastening holes in the bracket can be aligned with those of the guides without

Section 6 – Barrel and Brackets

the forks contacting the wall. Secure the barrel assembly to avoid the slipping off the tip of the forks.

⚠ WARNING

The addition of brackets may offset the balance slightly from when the “lift point” was marked. Check to make sure the assembly is properly balanced before hoisting.

2. Before hoisting, refer to the hardware sheet and ensure that the proper type and quantity of fasteners were provided for the bracket installation. Measure the distance between the brackets and compare that to your wall angles or tubes. Brackets are installed on the **inside** of the wall angles and on the **outside** of the tubes. Readjust the brackets as needed before hoisting.
3. Center the barrel assembly between the guides, keeping approximately 2 feet of clearance between the barrel assembly and wall/guides.
4. Raise the barrel assembly up to the approximate bracket mounting level. The brackets should be clear of the outer angles and inner guide shapes.

Note: Position the brackets in the upright position, with the mounting holes facing the wall, before moving the assembly towards the wall. It may be difficult to rotate the bracket when in close to the wall.

5. Slowly maneuver the barrel assembly towards the guide, and align the mounting holes of the brackets with those of the wall angles (or mounting angles if tubes are present).
6. Insert the specified bolts and snug tighten.

Section 6 – Barrel and Brackets

7. Check to see that the barrel is positioned properly between the brackets. That is, so that the proper amount of space is allowed between the barrel and the brackets. Typically the space is equal at both the operator and adjustor side. Adjust as necessary.
8. Place a level in the center of the curtain/barrel. The shaft must be level for proper operation. If the shaft is **not** level:
 - Check the dimensions of the brackets from the top of the bracket to the center of the barrel.
 - Verify that the bracket mounting fasteners are the same distance from the top of the bracket.
 - a. If the dimensions **are not** correct, contact the Service Department.
 - b. If the dimensions **are** correct, the floor may be out of level, causing the bracket mounting holes in the guides to be out of alignment.
9. Fully tighten mounting bolts to the torque specifications in this manual. See **Section 14** for torque specifications.

NOTICE

Proper pretension of the bracket mounting bolts will benefit the life of the bolts and brackets.

10. If the adjusting wheel was not previously installed, install it now. Do not install the adjustor pin yet.
11. Ensure the sprockets on the operator bracket are aligned. Tighten the set screws in the sprockets and bearing.

Section 7 – Motor Operator Installation

▪ **Motor Operator Installation:**

1. Unpack the motor operator from the shipping box and retrieve the *Operator Mounting Bracket* and bolts provided in the kit.
2. There are several motor mounting configurations that can be formed with the supplied components. Refer to the shop drawings and components supplied with the kit in order to identify the specific style of mounting ordered for the unit. Some of the types of mounting are:
 - Horizontal Top of Coil
 - Horizontal Front of Coil
3. Mount the operator mounting bracket to the operator using the supplied fasteners.
4. Mount the operator mounting bracket to the operator bracket according to the shop drawings using the supplied fasteners.
5. Install controls and wire the operator. Refer to the wiring diagram provided with the operator for proper connections and voltages. The controls should be installed in an area from which the door/opening is clearly visible. This will allow an individual operating the unit to make a visual inspection of the opening for any obstacles or other potential hazards before setting the door into motion.

Note: Do not attempt to set the upper and lower limits until the curtain is installed or released.

▪ **Attaching Additional Bracing (if required):**

1. Attach a clip angle to the operator mounting bracket and the bracing angle to the clip angle. Snug all bolts.
2. Mount the other supplied clip angle to the bracing angle and swing the bracing angle to the wall or structural support.
3. Align the mounting face of the clip angle with the face of the wall, mark and drill a mounting hole for the size of the supplied mounting fastener, and secure the clip angle to the wall with the fastener.
4. Square the operator-mounting bracket, adjusting the bracing angle as necessary, and fully tighten all the mounting bolts.
5. Lift the motor operator into position on the mounting bracket and align it with the appropriate hole pattern.
6. Insert the fasteners included in the kit from the bracket side first into the mounting foot of the operator and tighten the nuts with lock washers.

Note: All mounting bolts are supplied with nuts and lock washers.

Section 8 – Curtain Installation

▪ Curtain Installation

1. If not yet removed, remove the outer bellmouth from the guides. Additionally, you may remove the entire outer guide for more clearance.

⚠ WARNING

Do not remove the banding from the curtain/barrel until the operator has been attached and secured so that the barrel cannot rotate uncontrolled.

2. If the curtain has been supplied wrapped on the shaft from the factory, skip to step number 7.
3. Open the curtain packaging and identify all of the standard curtain slats and bottom bar.
4. After removing the banding holding the starter slats together, lower the door so that the slats hang below the bracket. Lace together the slats, attach the endlocks, and coil up the door as needed. It is important that the slats are aligned at this time. This can be accomplished by using the large vice grip or pliers to squeeze the slats between the groove and the end of the slat.
5. Continue to rotate the shaft and wrapping the curtain on the shaft until the bottom standard curtain slat is assembled. Lace together the bottom bar and bottom standard curtain slat at this time and attach the final endlocks. Make sure the at bottom reinforcement shape is installed in the bottom bar at this time. Coil up the door until the bottom bar reaches the bottom of the bracket.
6. If removed, replace the outer guides.
7. Lower the curtain such that the bottom bar is located in the removable bellmouth area. Replace the removable bellmouths at this time.
8. Feed the bottom bar into the guides and lower the curtain until the bottom bar is below the open location making sure to monitor the slats for alignment to each other.

Section 9 – Spring Release Set-up

▪ Applying Spring Turns:

1. Refer to the job information or markings on the shaft for the number of spring turns required on the unit.
2. To apply spring torque, remove cotter and stop pin from adjusting wheel.
3. Using two tensioning bars apply spring torque by inserting both bars into adjustor wheel one above the other.
4. Rotate wheel in a direction of raising the curtain. Maintain applied torque with upper bar, while removing lower bar. RE-insert this bar above the other and continue applying torque one notch at a time using this hand over hand procedure until the specified number of spring turns has been applied.
5. Replace stop pin into adjustor wheel and insert the cotter pin to hold it in place.
6. The spring will not hold the door in the open position. Ensure that the motor brake or safety pin is engaged prior to removing any devices applied to hold the door in the open position (clamps, slings, etc.).
7. Check curtain for ease of operation.
8. Final spring torque adjustment, if necessary, should be increased or decreased with the curtain in the fully open position.
9. Remove cotter pin and stop pin from adjustor wheel and begin to increase or decrease torque.
 - To increase torque, rotate the wheel in the direction of raising the curtain.
 - To decrease torque, carefully rotate the wheel in the direction of lowering the curtain.
10. Recheck the balance in one notch increments at a time. Re-insert stop pin, cotter pin and ensure that the door gravity closes (under alarm or no power supplied to operator).

Note: *If you have difficulty balancing the door, or the number of turns required to balance the door varies significantly from the quantity provided, contact the **Service Department**.*

Section 10 – Lintel Seal

▪ "Z" Shaped Seal

Note: The Lintel Seal should be installed before the hood and fascia, and after all other door components are installed and operational.

1. Clean and inspect the top of the opening where the *Lintel Seal* will be installed. See shop drawings for details.
2. Mark and drill the mounting holes in the extrusion. Ensure the mounting holes allow sufficient clearance for the fasteners being used to attach the lintel seal. The mounting holes should be spaced at a maximum of 24 inches apart. Position the holes equally between the front edge of the lintel and the back edge of the extrusion.
3. Place the lintel seal at the bottom of the lintel with the brush contacting the curtain (in the closed position) with the bristles pushed to about a 45-degree angle. (See **Figure 10.1**)

Figure 10.1 - "Z" Shaped Lintel Seal

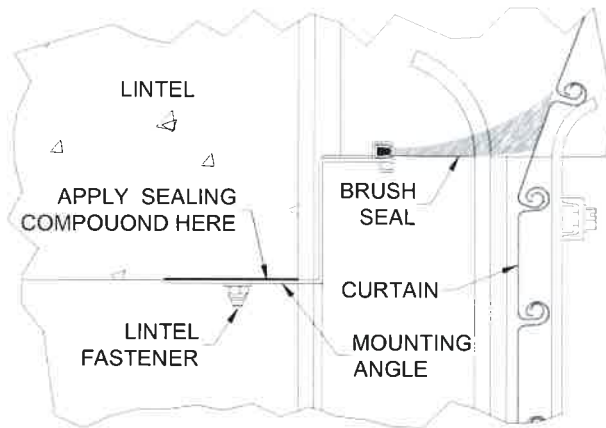

Note: Check the lintel brush for proper contact on the door curtain at the edges and in the middle when the door is both open and closed (mounting extrusion will not sit flush with the corner of the lintel in most cases). On large doors, toward the center, the multi-piece Lintel Seals may have to be angled inward and trimmed on the edges to follow the bow of the door curtain when closed. (Make sure that the brush stays in contact with the door and that the door does not hit the extrusion when it is fully opened.)

4. Once you determine the correct mounting position of the lintel seal, mark the mounting hole locations on the header using the previously drilled holes in the mounting extrusion as a template.
5. Remove the lintel seal and prepare the mounting hole locations for the proper fasteners supplied with the unit.
6. Replace the lintel seal in the opening and insert the fasteners. Make any adjustments the Lintel Seal and properly orient the multi-piece lintel seal (if present) and tighten the fasteners.
7. Operate the door and ensure that the lintel seal sustains sufficient contact with the curtain (The curtain should always touch the Lintel Seal and not hit the extrusion)

Section 10 – Lintel Seal

▪ "L" Shaped Seal

Note: The Lintel Seal should be installed before the hood and fascia, and after all other door components are installed and operational.

1. Clean and inspect the top of the opening where the *Lintel Seal* will be installed. See shop drawings for details.
2. Mount the angle to the lintel with the correct fasteners according to the wall construction. (Refer to the job information for the correct location of the angle from the lintel.)

Note: Check the lintel brush for proper contact on the door curtain at the edges and in the middle when the door is both open and closed. On large doors, toward the center, the multi-piece Lintel Seals may have to be angled inward and trimmed on the edges to follow the bow of the door curtain when closed. (Make sure that the brush stays in contact with the door and that the door does not hit the extrusion when it is fully opened)

3. Place the brush extrusion in place on the mounting angle so the brush makes contact with the door in the closed position. (Brush should be at about a 45-degree angle) Mark the mounting holes locations. Before removing the lintel seal, scribe a line on the back edge of the extrusion and mounting angle. This will help ensure the lintel seal is replaced in the correct location.
4. Remove the lintel seal. Drill the required pilot/clearance holes in the mounting extrusion. The mounting holes should be spaced at a maximum of 24 inches apart. Position the holes equally between the front and the back edges of the extrusion, or as needed to line up with the mounting angle.
5. Replace the lintel seal on the angle using the scribed line as a guide. Mark the mounting holes on the angle using the previously drilled holes in the mounting extrusion as a template. Remove lintel seal and drill the required pilot/clearance holes.
6. Attach the extrusion to the mounting angle with the proper fasteners.
7. Operate the door and ensure that the lintel seal sustains sufficient contact with the curtain (The curtain should always touch the Lintel Seal and not hit the extrusion).

Figure 10.2 - "L" Shaped Lintel Seal

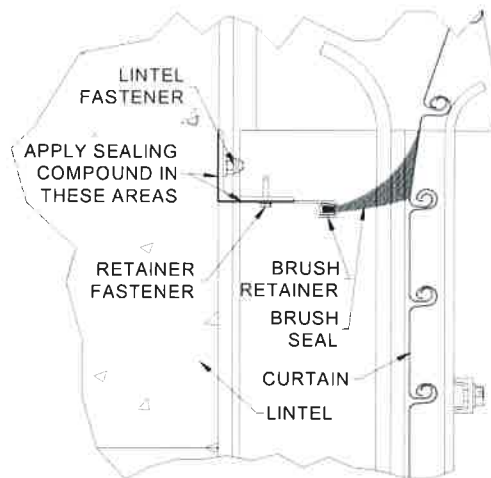

Section 11 – Hood Support Installation

▪ Hood Support Installation

1. Refer to the job information to determine the type and quantity of hood supports required for your door. Hood supports will be noted on the elevation view of the job construction drawings. See **Figure 11.1** for hood support types.

Figure 11.1 - Hood Supports

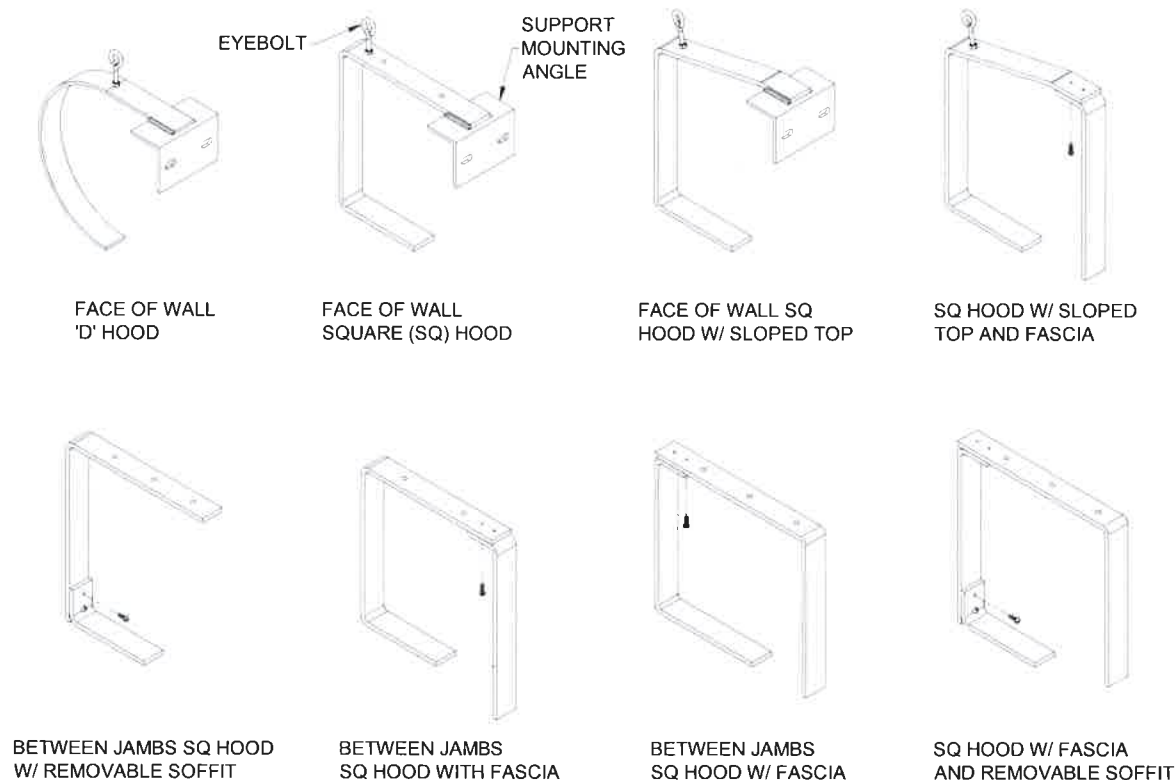

2. Determine where the support(s) will be located between the guides.
 - a. If multiple supports are required, see the job construction drawings to determine the centerline of each.
 - b. If a single support is required, it will be located at the center of the unit.
3. Mark a line on the lintel at the centerline of each support.
4. Check the construction at the support locations to be sure it is strong enough to handle the weight of the hood.

Note: *If the construction is not strong enough, do not proceed until rectified.*

5. The term "top of the coil" refers to the top edge of the brackets and hood which house the curtain (The curtain in the fully open position is referred to as the "coiled curtain". The top of the coiled curtain is not actually located at the "top of the coil", it is lower than the top of the coil) Locate the "top of the coil":
 - a. This is typically at the top of the wall angle or guide tube.
 - b. If there is a ceiling at the top of the coil, skip the next step.
6. Mark a line at the top of the coil at both guides of the unit. Project the lines together to make a continuous line.

Section 11 – Hood Support Installation

- a. This will help locate the top of the hood support which will keep the hood level.
7. Project a line from the fascia mounting location (fascia mounting channel or fascia side of the tube) from one guide to the other.
8. Mark a line at the support centerline along the fascia line.
9. Prepare the location of the attachment point of the support(s) prior to installing the barrel. This will make installing the support much easier when the time comes to attach it to the lintel/header or ceiling.
 - a. Hold the support in place at the determined location and mark the mounting hole locations.
 - b. Drill holes in the construction.
10. Attach the hood support to the lintel/header or ceiling to be sure the mounting holes were located properly.
11. Remove the hood support and proceed to the ***“Barrel and Brackets”*** section.
12. Once the barrel, brackets, curtain are installed, and necessary testing was done on the unit, re-install the hood support.

Section 12 – Hood, Fascia, and Covers

▪ Hood and Fascia Installation

1. Determine what type of hood was provided. This can be done by:
 - Looking for a 'D' hood strap or clip angles welded to the brackets.
 - Looking in the hood box and comparing to the job construction drawings.
2. If a square hood is provided, check the job construction drawings to see if it has multiple parts (such as a two sided hood with a removable soffit, two sided hood without a top piece, two sided hood with a sloped top, etc). See **Figure 12.1** for possible hood configurations.
3. Fasten the hood and fascia accordingly using the fasteners provided. Ensure hoods with multiple sections overlap correctly.
 - 'D' hoods end between the brackets.
 - Square hoods end flush with the outer edge of the brackets.
4. If there is a hood support:
 - 'D' hood sections overlap the centerline of the hood support by 1/2".
 - Square hood sections do **not** overlap at the hood support. They butt against each other and a hood splice cover is provided to cover the joint, see **Figure 12.2**.

Note: If there is a hood support, pre-drill holes in it to ease hood attachment. A #21 drill size is recommended.

Section 12 – Hood, Fascia, and Covers

Figure 12.1 - Hood Configurations

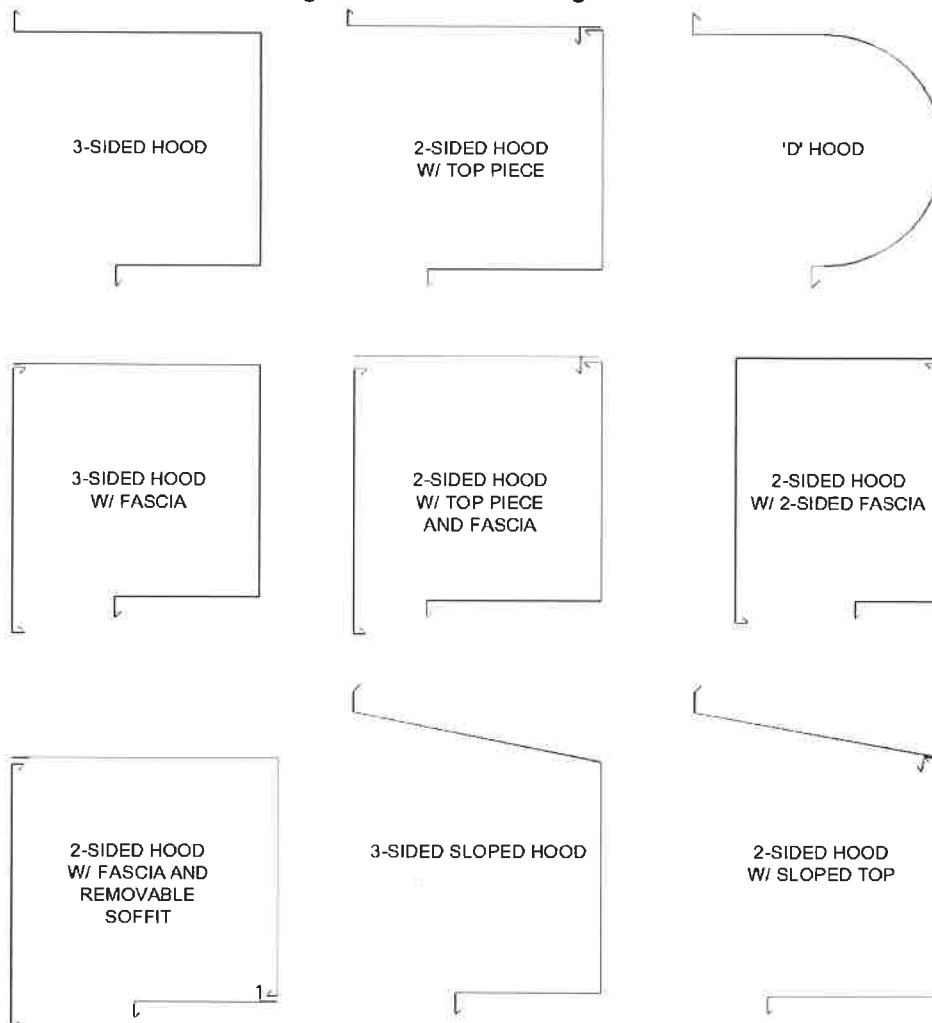

▪ Hood Splice Cover

1. Hood splice covers are provided for square hoods only. Prior to installing the splice cover, operate the door a few times once you've installed the hood, to verify that the hood is not interfering with the door.
2. Install the splice cover at this time.
3. Slip the bottom return bead on the splice cover into the soffit return on the hood, and then attach the top of the splice cover with the fasteners provided.
4. If there is not return bead on the soffit of the hood, fasten the bottom of the splice cover to the soffit.

Section 12 – Hood, Fascia, and Covers

Figure 12.2 - Hood Splice



Figure 12.3 – Hood and Cover Screw (#10-16 x 1/2")



▪ Cover installation

1. Once the unit is installed and operating correctly, the covers can be installed.
2. Hood screws may have to be removed and reinstalled to install covers properly.
3. If the cover mounts to the side of the door bracket, pre-drill holes in the bracket to ease installation. A #21 drill size is recommended

Figure 12.4 – Square Hood Mechanism Cover

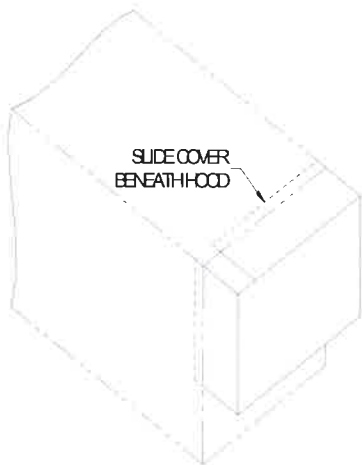

Figure 12.5 – 'D' Hood Mechanism Cover



Note: Mechanism covers differ from operator and adjustor covers in that operator and adjustor covers provide a complete enclosure.

4. If an operator or adjustor cover is provided, individual installation instructions are provided with each cover along with the necessary hardware to attach the cover.
5. Once the cover is installed, operate the door a few more times to be sure there is no interference between the moving components inside the cover and the cover itself.
6. If the door is mounted on the exterior of the building, a bead of silicone sealant should be applied around the entire perimeter of the cover, as it will provide additional protection to the door components.

Section 13 – Torque Specifications

Table 13.1 – Torque Recommendations for Guide Assembly and Wall Fasteners

Bolt size/type	Torque (ft-lbs) ^a
1/4-20 Grade 2 steel bolt	6
5/16-18 Black Oxide Socket Cap	25
3/8-16 18-8 stainless steel bolt	20
3/8-16 Grade 2 steel bolt	20
3/8-16 Grade 5 steel bolt	31
1/2-13 Grade 5 steel bolt	75
1/2-13 Grade 8 steel bolt	107
5/8-11 Grade 8 steel bolt	212
3/4-10 Grade 8 steel bolt	376
^a The recommended torque for steel bolts is based on a plated bolt that has not been lubricated.	

For Masonry Anchors, refer to manufacturers requirements.

Section 14 – Maintenance Schedule

▪ **Maintenance Schedule**

*Note: If any of the following problems exist, **do not** operate the door until repaired.*

Component	What to look for and how often the components must be inspected:	Weekly	Monthly	Quarterly	What to do if problem exists:
Curtain & Bottom Bar	Are any curtain components damaged (slats, endlocks, etc.)?	X			Contact Service about replacing damaged parts.
	Is bottom bar damaged?	X			Contact Service about replacing damaged parts.
	Are bottom bar fasteners in place and properly tightened?		X		Fasteners must be inspected/replaced and properly tightened.
	Are fasteners attaching curtain to the barrel in place and properly tightened?		X		Fasteners must be inspected/replaced and properly tightened.
	Do you notice any hang-ups, jamming or other problems preventing the door from moving smoothly throughout the opening?	X			Check for external issues, if none exist, contact Service.
	Do you notice any odd or excessive noise when the door is operated?	X			Check for external issues, if none exist, contact Service.
	If there is a bottom seal, is it damaged?		X		Contact Service about replacing damaged parts.
Brackets	Are brackets plumb and perpendicular with wall?			X	Contact Service.
	Are bracket fasteners in place and properly tightened?			X	Fasteners must be inspected/replaced and properly tightened.
	Do you notice signs of excessive wear on the bearings (i.e. binding, excessive noise, etc.)?		X		If there is a grease fitting, apply grease, if not, contact Service.
	Is adjusting wheel & pin secure?			X	Contact Service.
	Is drive chain sufficiently lubricated?			X	Apply chain lube.
	Is drive chain in need of tightening?			X	Contact Service
	Is drive or driven sprocket damaged?		X		Contact Service about replacing damaged parts.
Guides	Are wall fasteners in place and properly tightened?		X		Fasteners must be inspected/replaced and properly tightened.
	Are guide assembly fasteners in place and properly tightened?		X		Fasteners must be inspected/replaced and properly tightened.
	Is guide gap dimension correct?		X		Check job construction drawings and adjust gap as required. If job construction drawings are not available, contact Service.
	Are any of the guide parts bent or damaged?		X		Contact Service.
Hood and Fascia	Is hood/fascia dented or damaged?			X	Remove hood/fascia. Repair if possible. If not leave hood/fascia off and contact Service.
	Is curtain rubbing against the hood/fascia?	X			Hood/fascia may have been damaged. Contact Service.

Section 14 – Maintenance Schedule

	Is hood/fascia level?			X	Check fasteners, they may be loose or missing. Replace as soon as possible.
	Are guide assembly fasteners in place and properly tightened?		X		Fasteners must be inspected/replaced and properly tightened.
	Is hood support level?			X	Check fasteners, they may be loose or missing. Replace as soon as possible.
Door operation	Does the door require excessive force to open?		X		Check for hang-ups or obstructions. Ensure spring tension is set correctly. Contact Service.
	If there is a sensing edge, does it function properly?	X			Cut power and check for loose wires. Contact Service for further instruction.
Motor Operator	Are the fasteners attaching the motor-to-the mounting bracket, and mounting bracket-to- the door bracket secure?			X	Fasteners must be inspected/replaced and properly tightened. Contact Service for replacement hardware.
	Are the sprockets properly aligned?			X	Realign the sprockets as secure using the set screws. Recheck chain tension.
	Are the sprocket keys properly aligned with sprockets and securely fastened with the set screws?			X	Reposition the keys so they fully engage the keyway in the sprocket. Tighten the set screws.
	Is the door stopping correctly at the open (before bottom bar contacts the stoppers) and closed (as soon as the bottom bar contacts the floor) positions?		X		Limits may have to be adjusted in the motor operator. Refer to the operator owner's manual or contact Service.
	Is the operator functioning normally?		X		Refer to the <i>Operator Troubleshooting Table</i> on the following page to diagnose the problem.

Section 14 – Maintenance Schedule

▪ Operator Troubleshooting

Note: If you suspect you are having an issue with your operator, use the following table to determine the potential causes. If the provided solution does not eliminate the issue, or the table does not address your particular problem, contact the Service Department.

Component	Problem	Potential Cause	Solution
Motor Operator	Motor Operator does not run when OPEN or CLOSE button is pushed	The circuit breaker may be flipped or fuse blown.	Reset breaker or replace fuse. Contact Service if replacement fuse is needed.
		The thermal overload may be tripped.	Reset thermal overload.
		Manual interlock switch is open (on units with emergency operator).	Close manual interlocks.
		External interlock may be opened.	Close external interlock.
	Motor operator runs but the door does not move	Sprocket key may be missing or drive chain may be broken.	Contact Service for repair parts. Install key or replace chain.
		Clutch may be slipping.	Adjust if possible. Contact Service otherwise.
	Motor hums but does not run	Door or drive chain may be jamming.	Check for hang-ups or obstructions. Try to operate manually. If issue persists, contact Service.
		Dead phase in 3 phase system.	Check power supply.
		Brake does not release.	Check power to brake solenoid.
		Open motor winding.	Check that all connections are secure.
	Motor operator runs in wrong direction and limits do not function	3 phase operator power supply is out of phase.	Interchange any 2 power leads to unit.
	Door drifts when motor shuts off	Brake may be improperly adjusted or broken.	Check brake components. Contact Service for replacement parts or adjust instructions.
	Motor operator does not shut off at full OPEN or at full CLOSE position	Limits may need adjustment.	Refer to the operator owner's manual to readjust limits.
		Sprocket on limit shaft may be slipping or limit drive chain may be broken.	Ensure sprocket key is correctly installed and set screws are tightened. Contact Service for replacement chain if broken.
Limit switch may be defective.		Contact Service.	
Limit Switches	Limit switch does not hold setting	Drive chain may be too loose, allowing the chain to jump sprocket teeth.	Adjust chain to proper tension. Contact Service for additional information.
		Limit nut retainer not engaging slots in limit nuts.	Be sure retainer is securely engaged in slots of both limit nuts.
		Limit nuts binding on screw threads, allowing them to jump position on retainer.	Lube screw thread. Check that limit nuts turn freely.

Appendix A – Chain Sprocket Adjuster

▪ Chain Sprocket Adjuster

1. Loosen the shaft collar set screws. Remove the shaft collar and support strap from the adjusting wheel stud.
2. Place the bracket plate onto the inner shaft.
3. After the shaft sprocket is on the inner shaft, remove the 3/4"-10 x 1-1/2" bolts.
4. Install the square key into the shaft sprocket and inner shaft key seat.
5. Align the shaft sprocket with the sprocket on the adjusting wheel.
6. Tighten the set screws on the shaft sprocket to secure it to the inner shaft.
7. Place the support strap onto the adjusting wheel stud and over the inner shaft. Be sure that the washers are between the support strap and the adjusting wheel.
8. Replace the shaft collar on the adjusting wheel stud and tighten the set screws. When replacing shaft collar, allow clearance (.030") so that the adjusting wheel can rotate freely.

Figure 16.1 – Chain Sprocket Adjuster Assembly

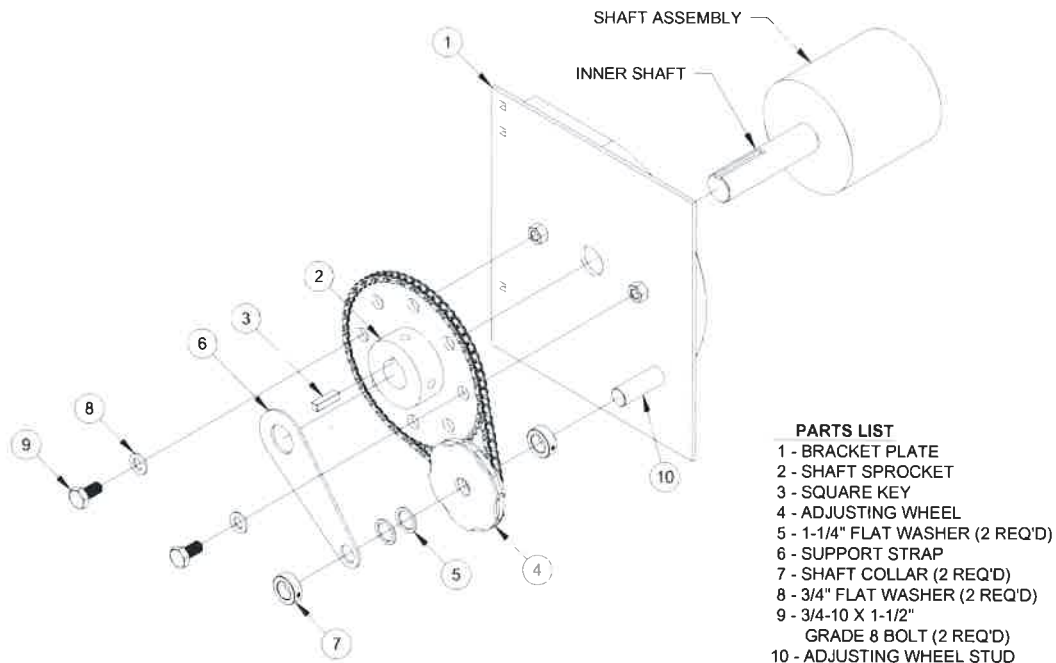

⚠ WARNING

Apply tension with door in the fully open position only. Do not operate door from the fully open position without first installing both 3/4"-10 x 1-1/2" grade 8 bolts. Roller chain is not intended to hold extreme loads and could break causing property damage and serious injury or death.

3. To apply spring turns, be sure the 3/4-10 x 1-1/2" grade 8 bolts are removed from the shaft sprocket.

Appendix A – Chain Sprocket Adjuster

4. Use a 1-1/8" high x 3/8" thick x 40" long ASTM A36 minimum bar to apply spring torque. See the job construction drawing (elevation view) for the number of initial spring turns to apply to the small adjusting wheel and the direction of rotation.
5. After the correct quantity of spring turns has been applied, use the 3/4"-10 x 1-1/2" Grade 8 bolts to fasten the shaft sprocket to the bracket plate. Torque bolts to 365 - 375 ft-lbs