

DESIGN LOAD CAPACITY - PSF			
PANEL WIDTH NOMINAL INCHES	DOOR HEIGHT INCHES	9/16" OVERALL LAM. GLASS	
		EXT.(+)	INT.(-)
36	82	90.0	90.0
42		90.0	90.0
48		90.0	90.0
49		90.0	90.0
50		90.0	90.0
54		83.3	83.3
57		78.9	78.9
60		75.0	75.0
36	90	90.0	90.0
42		90.0	90.0
48		90.0	90.0
49		90.0	90.0
50		90.0	90.0
54		83.3	83.3
57		78.9	78.9
60		75.0	75.0
36	96	90.0	90.0
42		90.0	90.0
48		90.0	90.0
49		90.0	90.0
50		90.0	90.0
54		83.3	83.3
57		78.9	78.9
60		75.0	75.0
36	102	90.0	90.0
42		90.0	90.0
48		90.0	90.0
49		90.0	90.0
50		90.0	90.0
54		83.3	83.3
57		78.9	78.9
60		75.0	75.0
36	108	90.0	90.0
42		90.0	90.0
48		90.0	90.0
49		90.0	90.0
50		90.0	90.0
54		83.3	83.3
57		78.9	78.9
60		75.0	75.0
36	110	90.0	90.0
42		90.0	90.0
48		90.0	90.0
49		90.0	90.0
50		90.0	90.0
54		83.3	83.3
57		78.9	78.9
60		75.0	75.0

INTERPOLATION BETWEEN WIDTHS AND HEIGHTS ACCEPTABLE

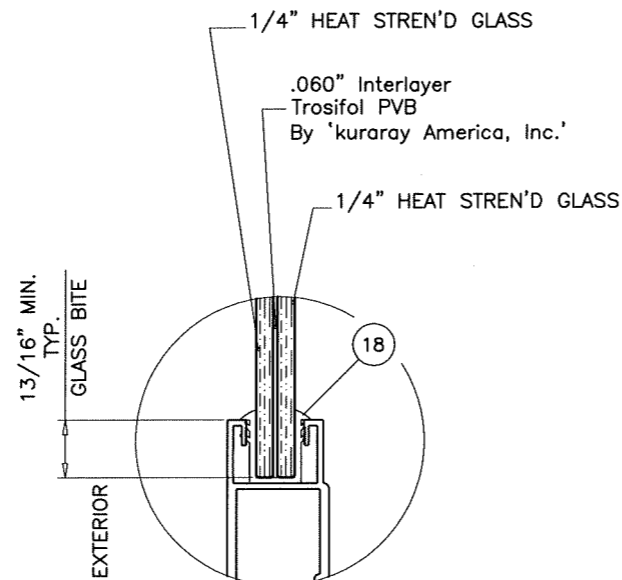

GLAZING DETAIL
9/16" OVERALL LAM. GLASS

NOTE:
GLASS CAPACITIES ON THIS SHEET ARE
BASED ON ASTM E1300-09 (3 SEC. GUSTS)
AND FLORIDA BUILDING COMMISSION
DECLARATORY STATEMENT DCA05-DEC-219

THESE DOORS ARE RATED FOR SMALL MISSILE IMPACT.
F.B.C. APPROVED IMPACT RESISTANT SHUTTERS REQUIRED
FOR INSTALLATIONS UP TO 30 FT. OF GRADE.
SHUTTERS NOT REQD. FOR INSTALLATIONS ABOVE 30 FT. OF GRADE.

SERIES 44
ALUMINUM SLIDING GLASS DOOR (S.M.I.)

DESIGN LOAD RATING FOR DOORS TO BE AS PER CHARTS
SHOWN ABOVE.

THIS PRODUCT HAS BEEN DESIGNED AND TESTED TO COMPLY WITH THE
REQUIREMENTS OF THE 2017 (6TH EDITION) FLORIDA BUILDING CODE
INCLUDING HIGH VELOCITY HURRICANE ZONE (HVHZ).

1BY OR 2BY WOOD BUCKS & BUCK FASTENERS BY OTHERS, MUST BE
DESIGNED AND INSTALLED ADEQUATELY TO TRANSFER APPLIED PRODUCT LOADS
TO THE BUILDING STRUCTURE.

ANCHORS SHALL BE CORROSION RESISTANT, SPACED AS SHOWN ON DETAILS
AND INSTALLED PER MANUF'S INSTRUCTIONS. SPECIFIED EMBEDMENT TO BASE
MATERIAL SHALL BE BEYOND WALL DRESSING OR STUCCO.

A LOAD DURATION INCREASE IS USED IN DESIGN OF ANCHORS INTO WOOD ONLY.

ALL SHIMS TO BE HIGH IMPACT, NON-METALLIC AND NON-COMPRESSIBLE.

MATERIALS INCLUDING BUT NOT LIMITED TO STEEL/METAL SCREWS, THAT
COME INTO CONTACT WITH OTHER DISSIMILAR MATERIALS SHALL MEET THE
REQUIREMENTS OF THE 2017 FLORIDA BLDG. CODE & ADOPTED STANDARDS.

THIS PRODUCT APPROVAL IS GENERIC AND DOES NOT PROVIDE INFORMATION
FOR A SITE SPECIFIC PROJECT, i.e. LIFE SAFETY OF THIS PRODUCT, ADEQUACY
OF STRUCTURE RECEIVING THIS PRODUCT AND SEALING AROUND OPENING FOR
WATER INFILTRATION RESISTANCE ETC.
CONDITIONS NOT SHOWN IN THIS DRAWING ARE TO BE ANALYZED SEPARATELY,
AND TO BE REVIEWED BY BUILDING OFFICIAL.

MANUFACTURER'S LABEL SHALL BE LOCATED ON A READILY VISIBLE LOCATION
IN ACCORDANCE WITH SECTION 1709.9.3 OF FLORIDA BUILDING CODE.
LABELING TO COMPLY WITH SECTION 1709.9.2.

- A- CONTRACTOR TO BE RESPONSIBLE FOR THE SELECTION, PURCHASE AND
INSTALLATION OF THIS PRODUCT BASED ON THIS PRODUCT EVALUATION
PROVIDED HE/SHE DOES NOT DEVIATE FROM THE CONDITIONS DETAILED
ON THIS DOCUMENT.
- B- THIS PRODUCT EVALUATION DOCUMENT WILL BE CONSIDERED INVALID IF
ALTERED BY ANY MEANS.
- C- SITE SPECIFIC PROJECTS SHALL BE PREPARED BY A FLORIDA REGISTERED
ENGINEER OR ARCHITECT WHICH WILL BECOME THE ENGINEER OF RECORD (E.O.R.)
FOR THE PROJECT AND WHO WILL BE RESPONSIBLE FOR THE PROPER
USE OF THE P.E.D. ENGINEER OF RECORD, ACTING AS A DELEGATED
ENGINEER TO THE P.E.D. ENGINEER SHALL SUBMIT TO THIS LATTER THE SITE
SPECIFIC DRAWINGS FOR REVIEW.
- D- THIS P.E.D. SHALL BEAR THE DATE AND ORIGINAL SEAL AND SIGNATURE OF
THE PROFESSIONAL ENGINEER OF RECORD THAT PREPARED IT.

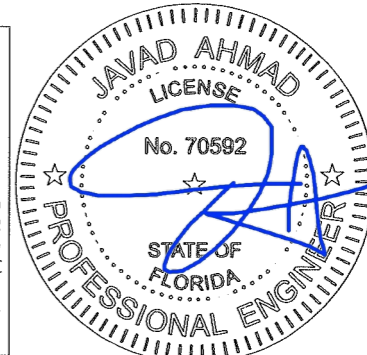

FL #22264

afC
AL-FAROOQ CORPORATION
ENGINEERS & PRODUCT DEVELOPMENT
9360 SUNSET DRIVE, SUITE 220
MIAMI, FLORIDA 33173 (C.A.N. 3538)
TEL. (305) 264-8100 FAX. (305) 262-6978
COMP-ANL\W17-25CGD

SERIES 44 ALUMINUM SLIDING GLASS DOOR (S.M.I.)
CRAWFORD GLASS DOOR COMPANY, INC.
3301 S.W. 13TH DRIVE, SUITE B
DEERFIELD BEACH, FL. 33442-8101
TEL. (954) 480-6820 FAX. (954) 480-6814

no.	date	description
A	02.08.18	UPDATED TO 2017 FBC

revisions:

date: 03-03-17
scale: -
dr. by: TARIQ
chk. by:

drawing no.
W17-25

sheet 1 of 15

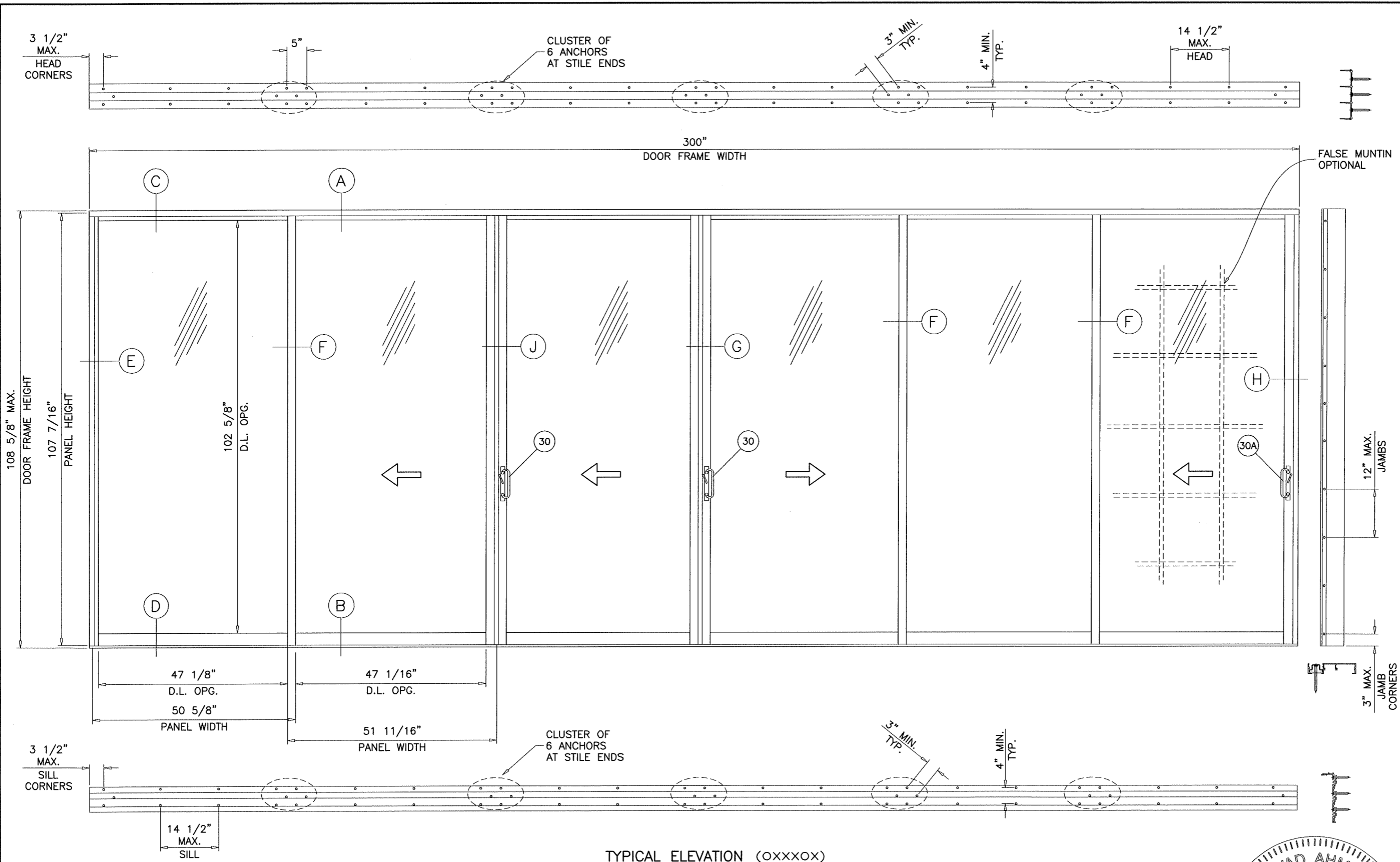

TYPICAL ELEVATION (OXXXX)
TESTED UNIT (3 TRACKS)

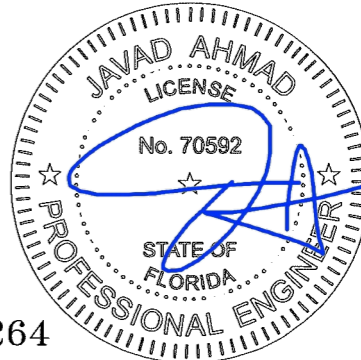

FL #22264

Sealed: 2/19/2018

afc
AL-FAROOQ CORPORATION
 ENGINEERS & PRODUCT DEVELOPMENT
 9360 SUNSET DRIVE, SUITE 220
 MIAMI, FLORIDA 33173 (C.A.N. 3538)
 TEL. (305) 264-8100 FAX. (305) 262-6978
 COMP-ANL\W17-25CGD

SERIES 44 ALUMINUM SLIDING GLASS DOOR (S.M.I.)
CRAWFORD GLASS DOOR COMPANY, INC.
 3301 S.W. 13TH DRIVE, SUITE B
 DEERFIELD BEACH, FL. 33442-8101
 TEL. (954) 480-6820 FAX. (954) 480-6814

revisions:	no.	date	by	description

date: 03-03-17
 scale: 1/2"=1'-0"
 dr. by: TARIQ
 chk. by:

drawing no.
W17-25
 sheet 3 of 15

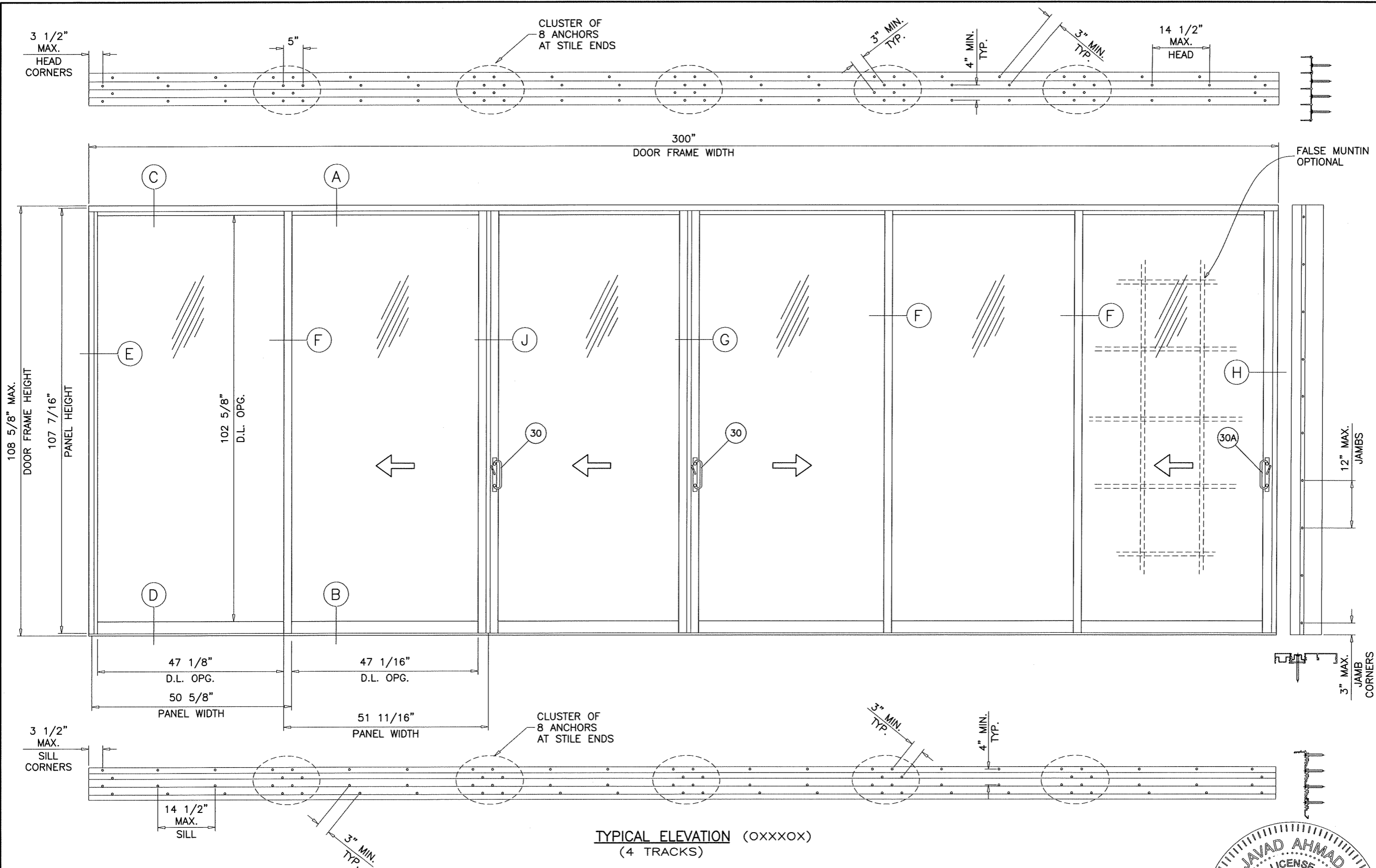

TYPICAL ELEVATION (OXXXXO)
(4 TRACKS)

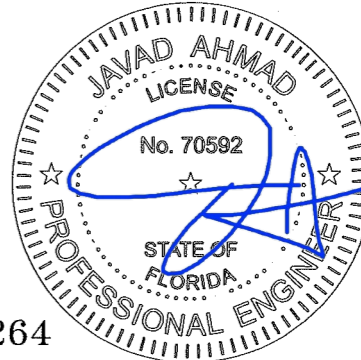

FL #22264

af c
AL-FAROOQ CORPORATION
 ENGINEERS & PRODUCT DEVELOPMENT
 9360 SUNSET DRIVE, SUITE 220
 MIAMI, FLORIDA 33173 (C.A.N. 3538)
 TEL (305) 264-8100 FAX (305) 262-6978
 COMP-ANL\W17-25CGD

SERIES 44 ALUMINUM SLIDING GLASS DOOR (S.M.I.)
CRAWFORD GLASS DOOR COMPANY, INC.
 3301 S.W. 13TH DRIVE, SUITE B
 DEERFIELD BEACH, FL. 33442-8101
 TEL. (954) 480-6820 FAX. (954) 480-6814

revisions:	
no	date by description

date: 03-03-17	scale: 1/2"=1'-0"	dr. by: TARIQ	chk. by:
drawing no. W17-25			
sheet 4 of 15			

NOTE:
 CONFIGURATIONS SHOWN FOR ILLUSTRATION PURPOSE ONLY
 (SEE APPLICABLE ANCHOR INSTALLATIONS IN SHEETS 8 THRU 12)

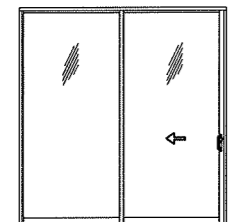

OX (SHOWN)
 XO

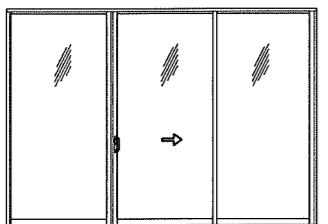
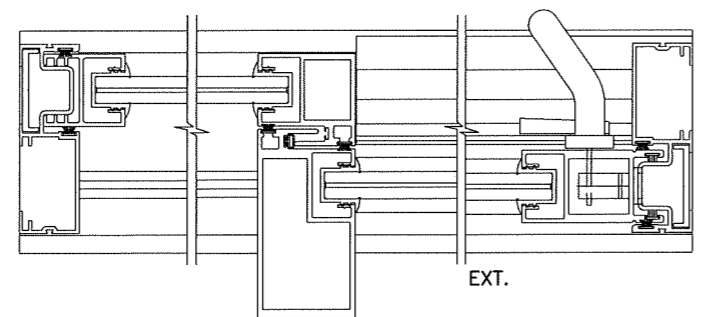

OXO (SHOWN)

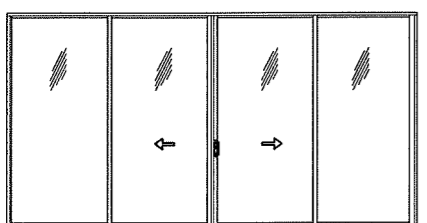
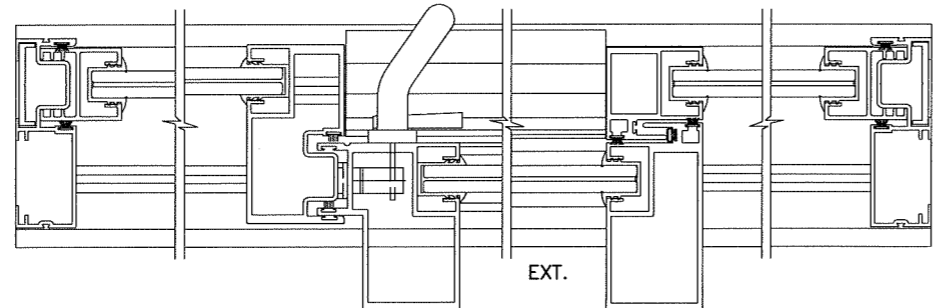

OXXO (SHOWN)

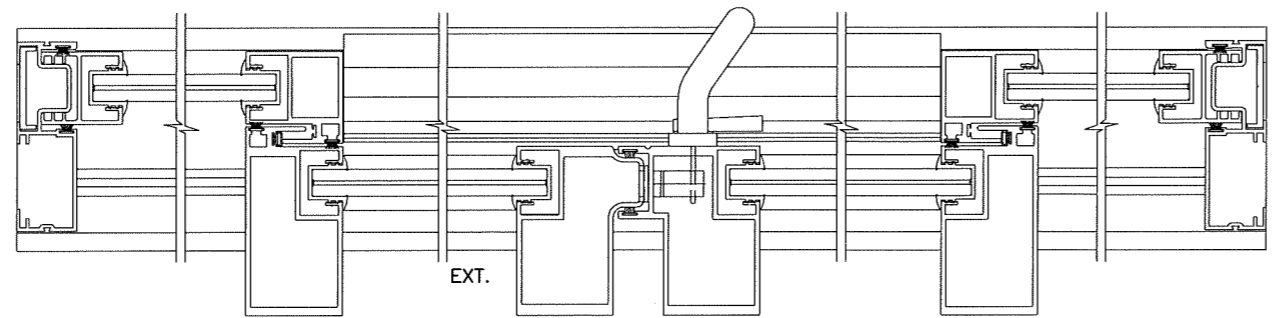

APPROVED CONFIGURATIONS
TWO (2) TRACKS

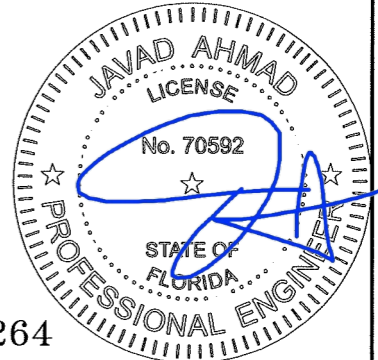

FL #22264

Sealed: 2/19/2018

afc
AL-FAROOQ CORPORATION
 ENGINEERS & PRODUCT DEVELOPMENT
 9360 SUNSET DRIVE, SUITE 220
 MIAMI, FLORIDA 33173 (C.A.N. 3538)
 TEL. (305) 262-6978 FAX. (305) 262-6978
 COMP-ANL W17-25CGD

SERIES 44 ALUMINUM SLIDING GLASS DOOR (S.M.I.)
CRAWFORD GLASS DOOR COMPANY, INC.
 3301 S.W. 13TH DRIVE, SUITE B
 DEERFIELD BEACH, FL. 33442-8101
 TEL. (954) 480-6820 FAX. (954) 480-6814

revisions:		no.	date	by	description

date: 03-03-17
 scale: -
 dr. by: TARIQ
 chk. by: -

drawing no.
W17-25
 sheet 5 of 15

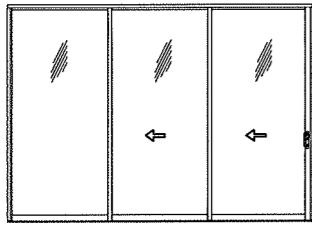

OXX (SHOWN)
XXO

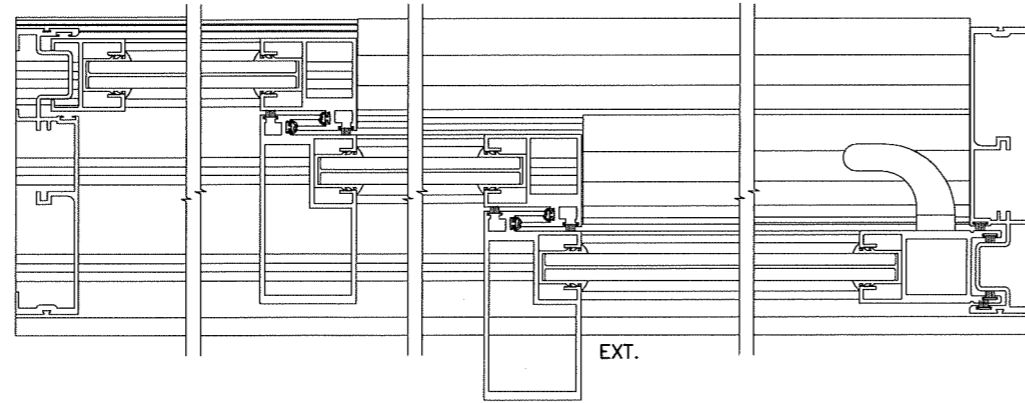

EXT.

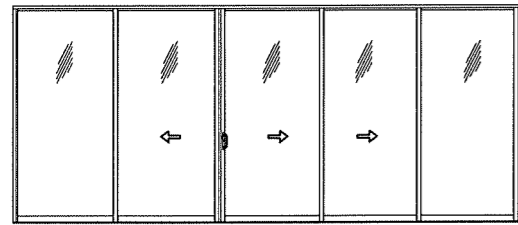

OX-XXO (SHOWN)

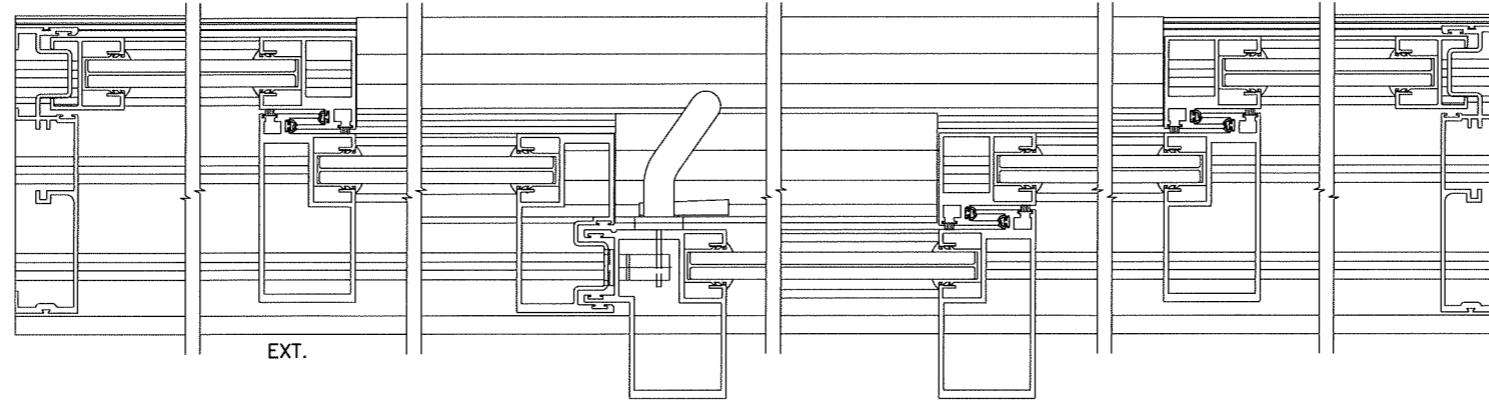

EXT.

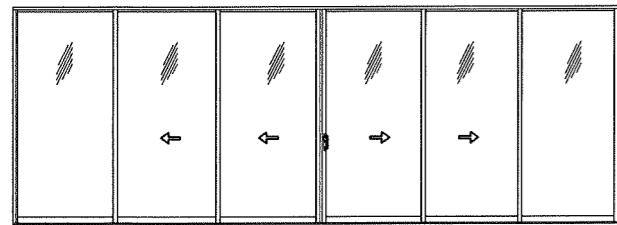

OXX-XXO (SHOWN)

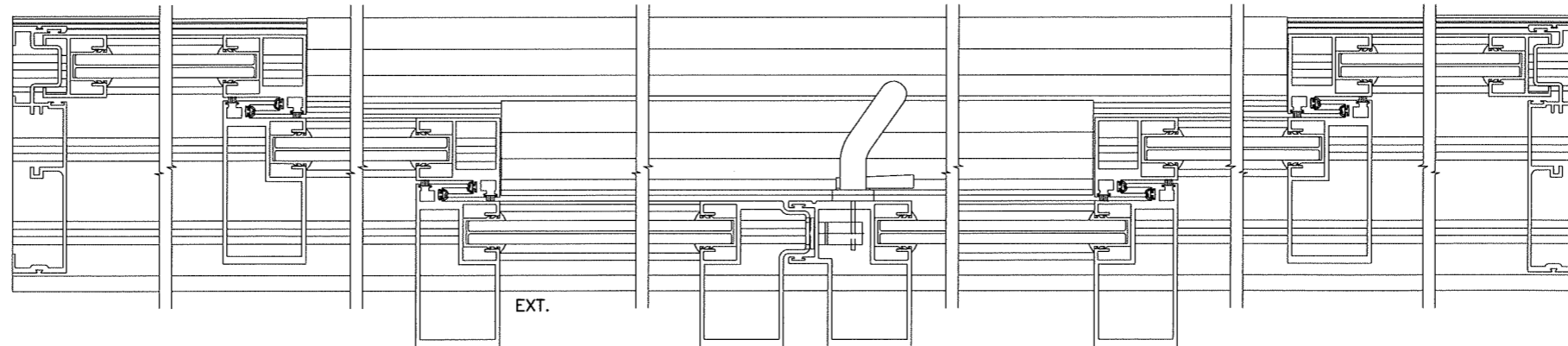

EXT.

NOTE:
CONFIGURATIONS SHOWN FOR ILLUSTRATION PURPOSE ONLY
(SEE APPLICABLE ANCHOR INSTALLATIONS IN SHEETS 8 THRU 12)

APPROVED CONFIGURATIONS
THREE (3) TRACKS

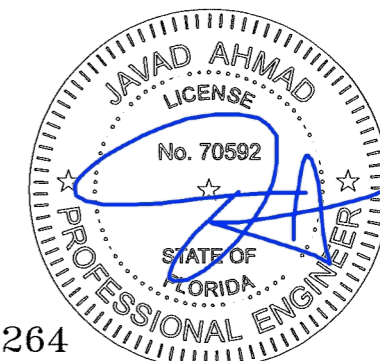

FL #22264

af c
AL-FAROOQ CORPORATION
ENGINEERS & PRODUCT DEVELOPMENT
9360 SUNSET DRIVE, SUITE 220
MIAMI, FLORIDA 33173 (C.A.N. 3538)
TEL. (305) 264-8100 FAX. (305) 262-6978
COMP-ANL\W17-25CGD

SERIES 44 ALUMINUM SLIDING GLASS DOOR (S.M.I.)
CRAWFORD GLASS DOOR COMPANY, INC.
3301 S.W. 13TH DRIVE, SUITE B
DEERFIELD BEACH, FL. 33442-8101
TEL. (954) 480-6820 FAX. (954) 480-6814

revisions:	no.	date	by	description

date: 03-03-17
scale: -
dr. by: TARIQ
chk. by:

drawing no.
W17-25
sheet 6 of 15

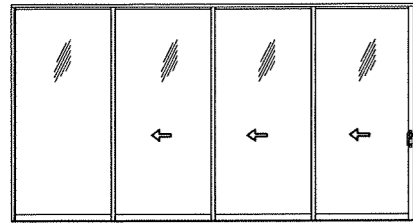

OXXX (SHOWN)
XXXX

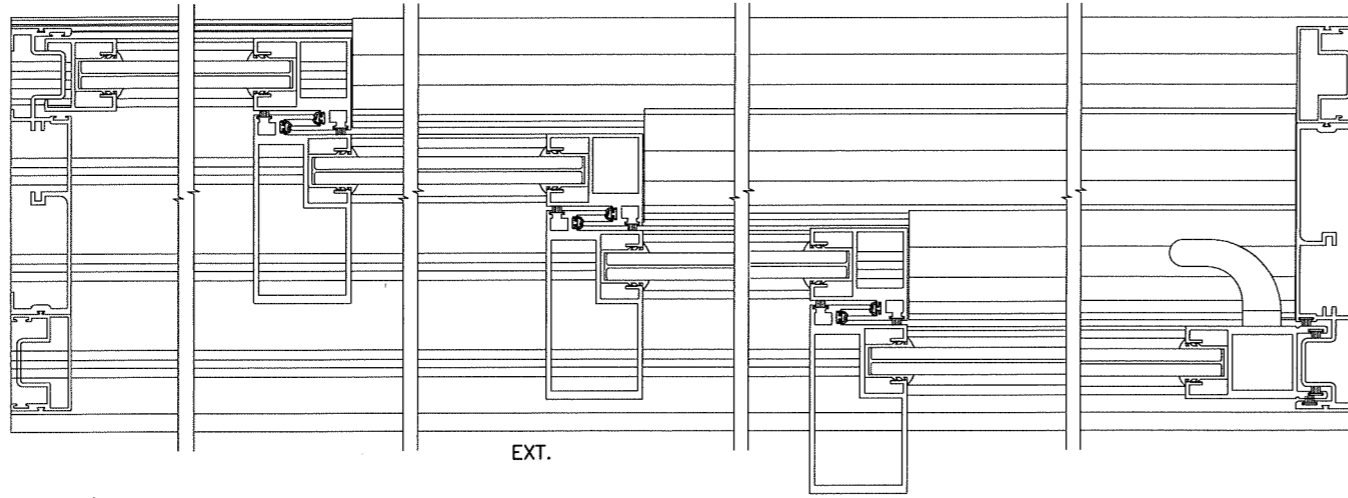

EXT.

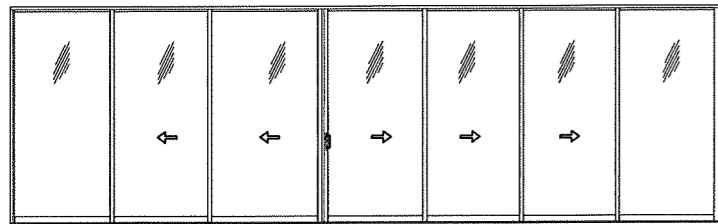

OXX-XXXX (SHOWN)

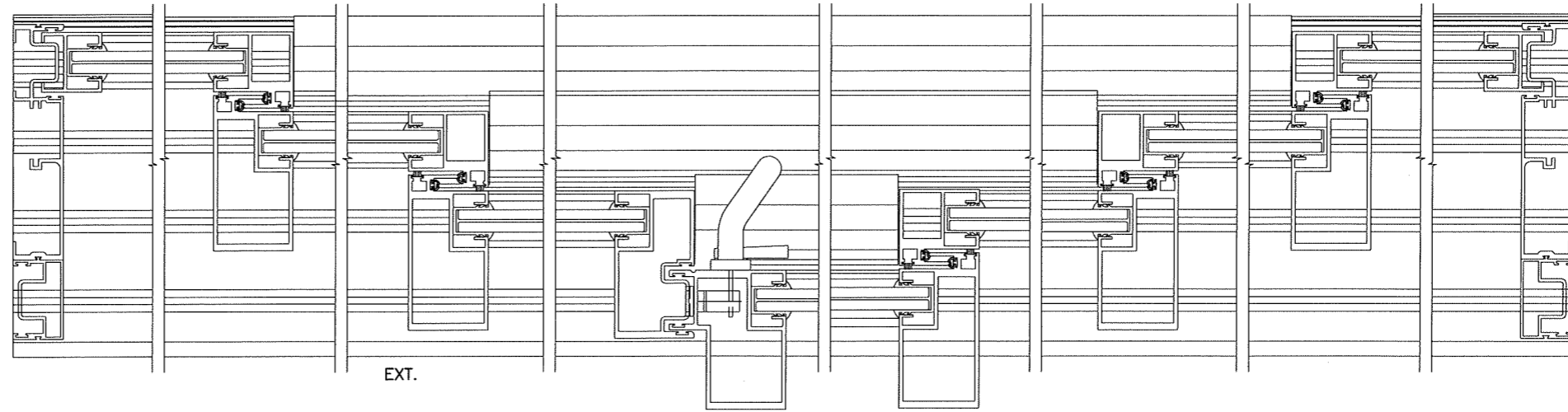

EXT.

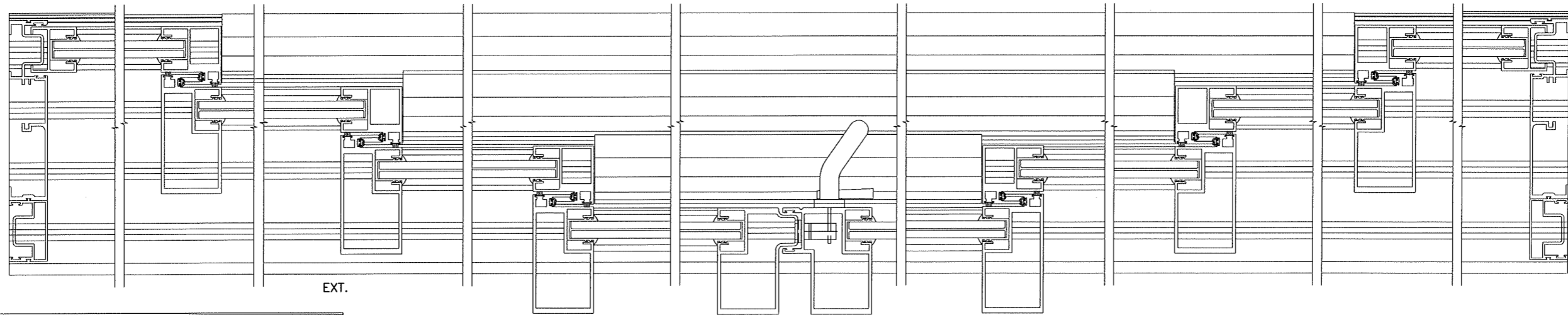

EXT.

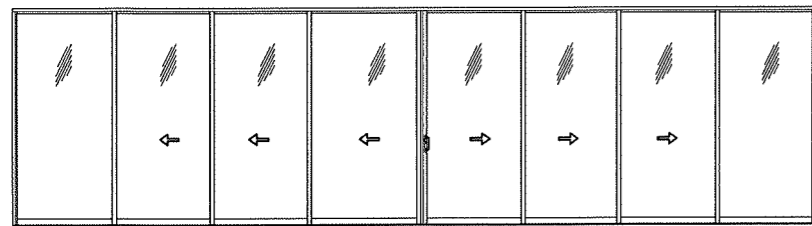

OXXX-XXXX (SHOWN)

NOTE:
CONFIGURATIONS SHOWN FOR ILLUSTRATION PURPOSE ONLY
(SEE APPLICABLE ANCHOR INSTALLATIONS IN SHEETS 8 THRU 12)



AL-FAROOQ CORPORATION
ENGINEERS & PRODUCT DEVELOPMENT
9360 SUNSET DRIVE, SUITE 220
MIAMI, FLORIDA 33173 (C.A.N. 3538)
TEL. (305) 264-8100 FAX. (305) 262-6978

COMP-ANL\W17-25CGD

SERIES 44 ALUMINUM SLIDING GLASS DOOR (S.M.I.)

CRAWFORD GLASS DOOR COMPANY, INC.

3301 S.W. 13TH DRIVE, SUITE B
DEERFIELD BEACH, FL. 33442-8101
TEL. (954) 480-6820 FAX. (954) 480-6814

revisions:	no	date	by	description

date:	03-03-17
scale:	-
dr. by:	TARIQ
chk. by:	

drawing no.
W17-25
sheet 7 of 15

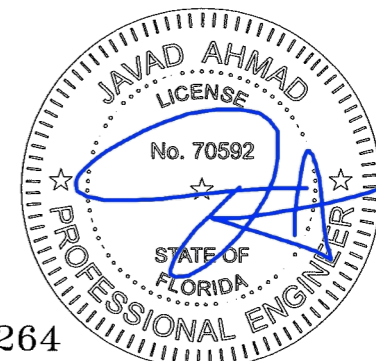

APPROVED CONFIGURATIONS
FOUR (4) TRACKS

FL #22264

Sealed: 2/19/2018

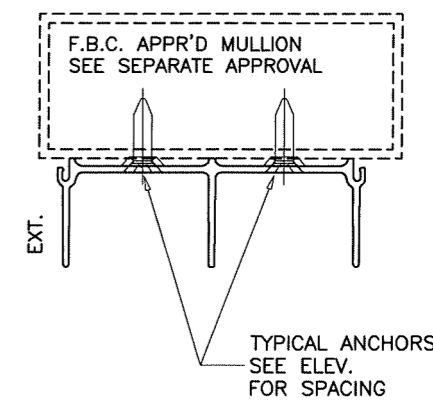
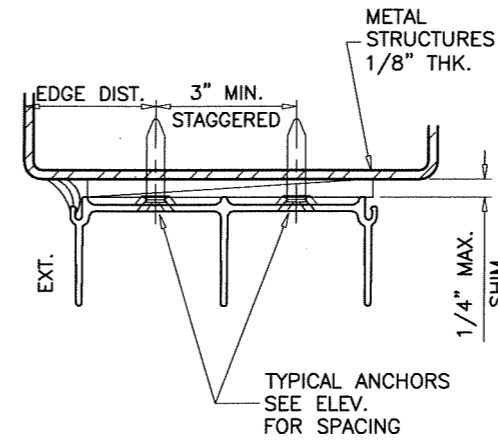
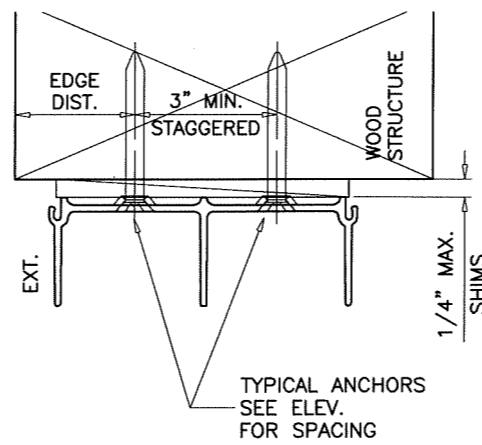
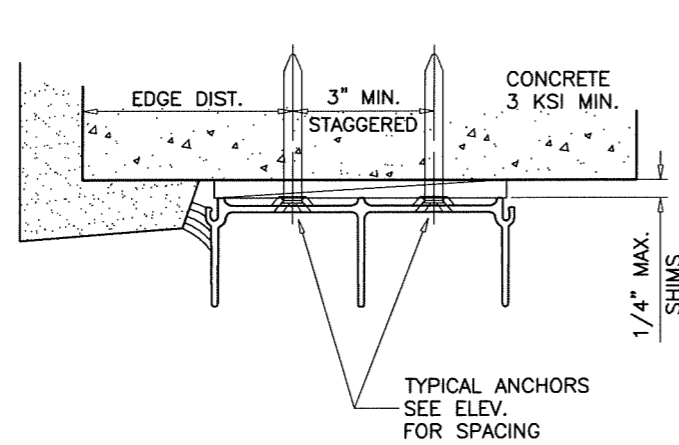

1BY OR 2BY WOOD BUCKS AND METAL STRUCTURE NOT BY CRAWFORD DOOR MUST SUSTAIN LOADS IMPOSED BY GLAZING SYSTEM AND TRANSFER THEM TO THE BUILDING STRUCTURE.

- TYPICAL ANCHORS:** SEE ELEV. FOR SPACING
- 5/16" DIA. ULTRACON BY 'ELCO'** (Fu=177 KSI, Fy=155 KSI)
- INTO WOOD STRUCTURES
 - 1-7/8" MIN. PENETRATION INTO WOOD (HEAD/JAMBS)
 - THRU 1BY OR 2BY WOOD BUCKS INTO CONC. OR BLOCKS
 - 1-1/4" MIN. EMBED INTO CONCRETE (HEAD/JAMBS)
 - 1-1/4" MIN. EMBED INTO BLOCKS (JAMBS)
 - DIRECTLY INTO CONCRETE OR BLOCKS
 - 1-3/4" MIN. EMBED INTO CONCRETE (HEAD/SILL/JAMBS)
 - 1-3/4" MIN. EMBED INTO GROUT FILLED BLOCKS (JAMBS)

- 5/16" DIA. TEKS OR SELF DRILLING SCREWS** (GRADE 5 CRS)
- INTO F.B.C. APPROVED MULLIONS
 - OR
 - INTO METAL STRUCTURES (HEAD/JAMBS)
 - (3) THREADS MIN. TO EXTEND BEYOND METAL THICKNESS
 - ALUMINUM: 1/8" THK. MIN. (6063-T5 MIN.)
 - STEEL: 1/8" THK. MIN. (Fy = 36 KSI MIN.)
 - (STEEL IN CONTACT WITH ALUMINUM TO BE PLATED OR PAINTED)

- TYPICAL EDGE DISTANCE**
- INTO CONCRETE AND BLOCKS = 2-1/2" MIN.
 - INTO WOOD STRUCTURE = 1-1/4" MIN.
 - INTO METAL STRUCTURE = 3/4" MIN.
 - WOOD AT HEAD OR JAMBS SG = 0.55 MIN.
 - CONCRETE AT HEAD, SILL OR JAMBS f'c = 3000 PSI MIN.
 - C-90 GROUT FILLED BLOCK AT JAMBS f'm = 2000 PSI MIN.

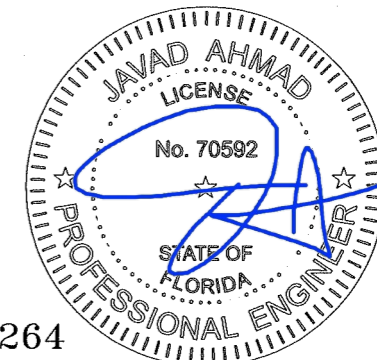

FL #22264

af c

AL-FAROOQ CORPORATION
 ENGINEERS & PRODUCT DEVELOPMENT
 9360 SUNSET DRIVE, SUITE 220
 MIAMI, FLORIDA 33173 (C.A.N. 3538)
 TEL. (305) 264-8100 FAX. (305) 262-6978

SERIES 44 ALUMINUM SLIDING GLASS DOOR (S.M.I.)

CRAWFORD GLASS DOOR COMPANY, INC.
 3301 S.W. 13TH DRIVE, SUITE B
 DEERFIELD BEACH, FL. 33442-8101
 TEL. (954) 480-6820 FAX. (954) 480-6814

revisions:	
no	date by description

date: 03-03-17
 scale: 3/8" = 1"
 dr. by: TARIQ
 chk. by:

drawing no.
W17-25

sheet 9 of 15

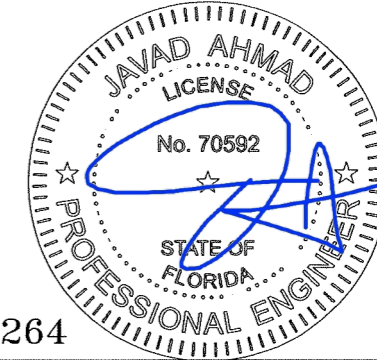
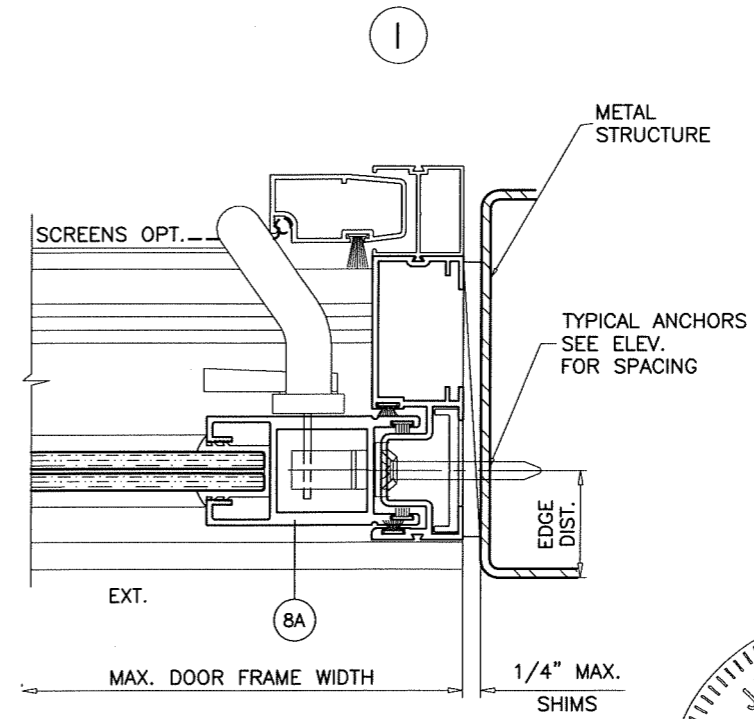
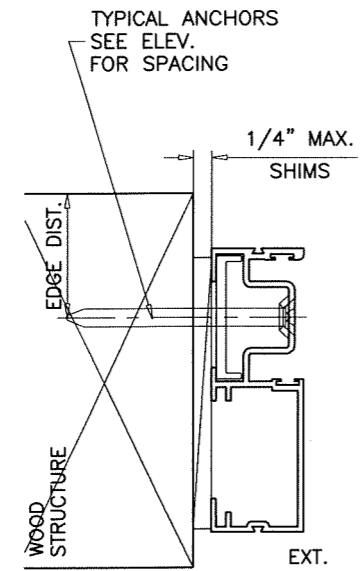
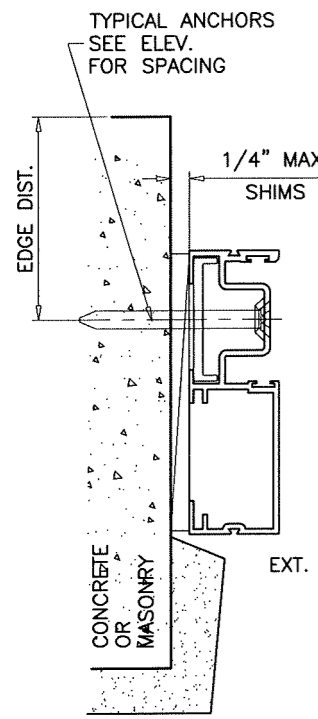
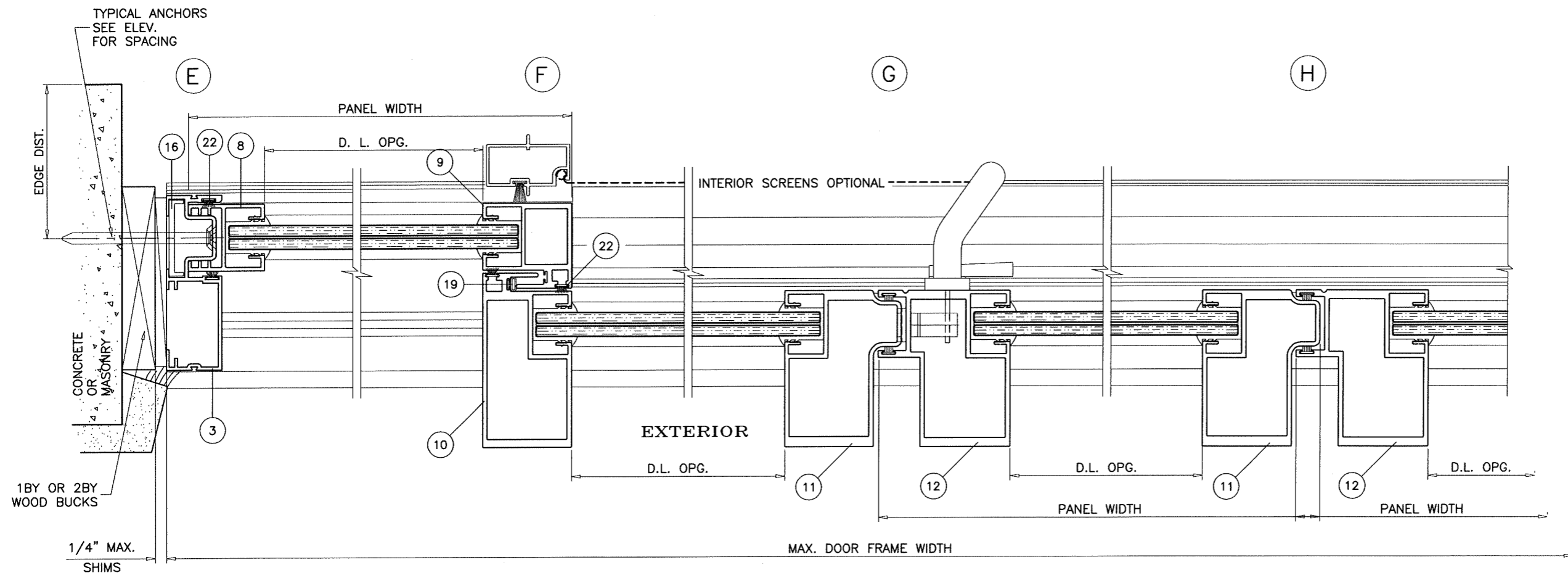

FL #22264

Sealed: 2/19/2018

af c
AL-FAROOQ CORPORATION
 ENGINEERS & PRODUCT DEVELOPMENT
 9360 SUNSET DRIVE, SUITE 220
 MIAMI, FLORIDA 33173 (C.A.N. 3538)
 TEL. (305) 264-8100 FAX. (305) 262-6978
 COMP-ANL\W17-25CGD

SERIES 44 ALUMINUM SLIDING GLASS DOOR (S.M.I.)
CRAWFORD GLASS DOOR COMPANY, INC.
 3301 S.W. 13TH DRIVE, SUITE B
 DEERFIELD BEACH, FL. 33442-8101
 TEL. (954) 480-6820 FAX. (954) 480-6814

revisions:	
no	date by description

date: 03-03-17
 scale: 3/8" = 1"
 dr. by: TARIQ
 chk. by:

drawing no.
W17-25
 sheet 10 of 15

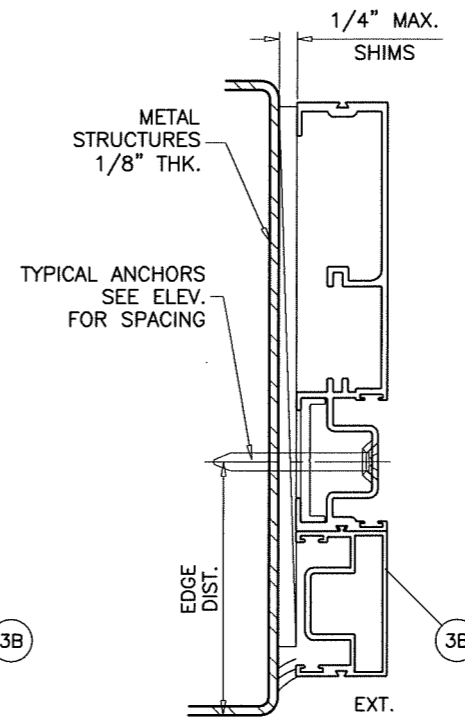
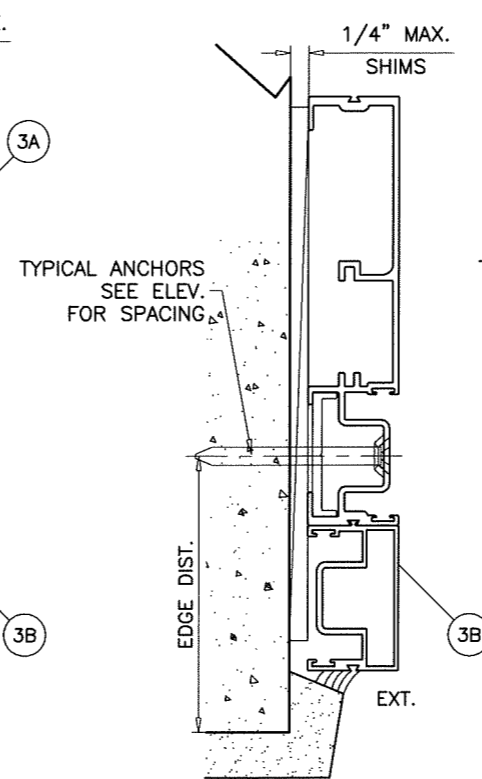
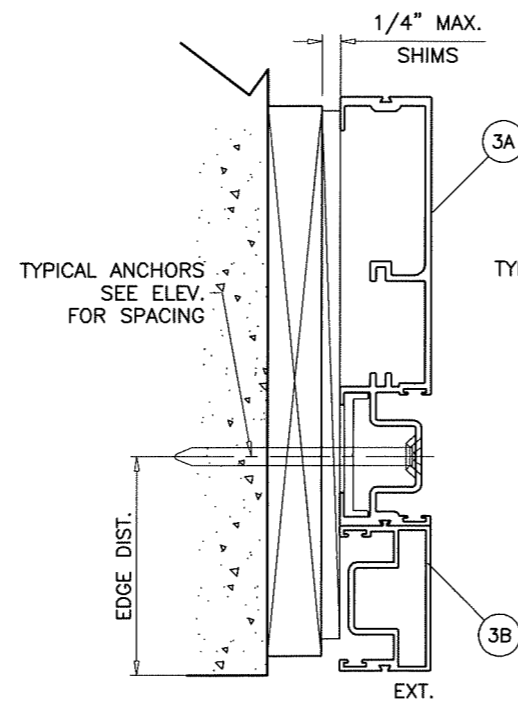
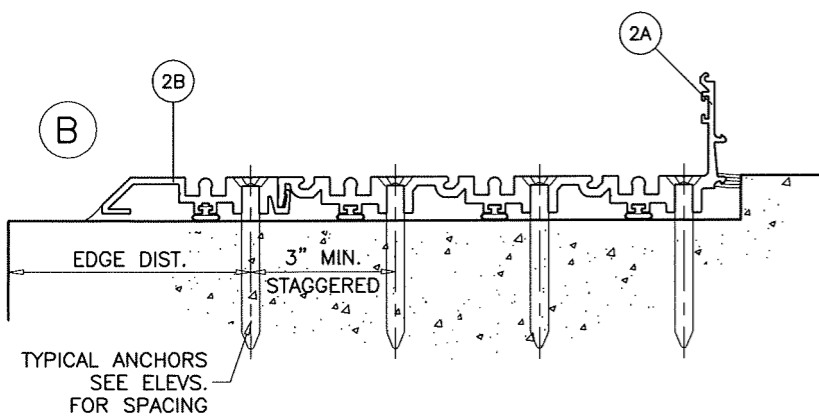
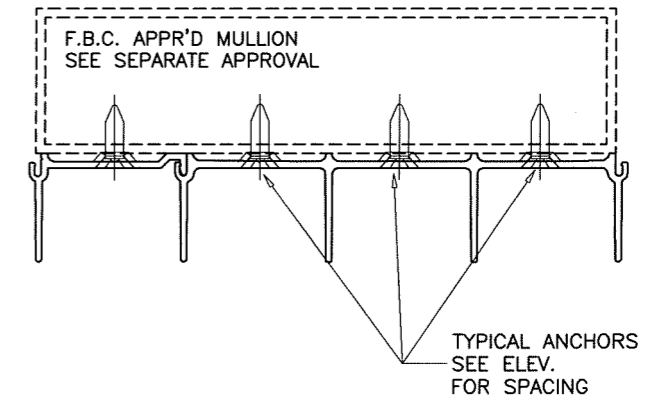
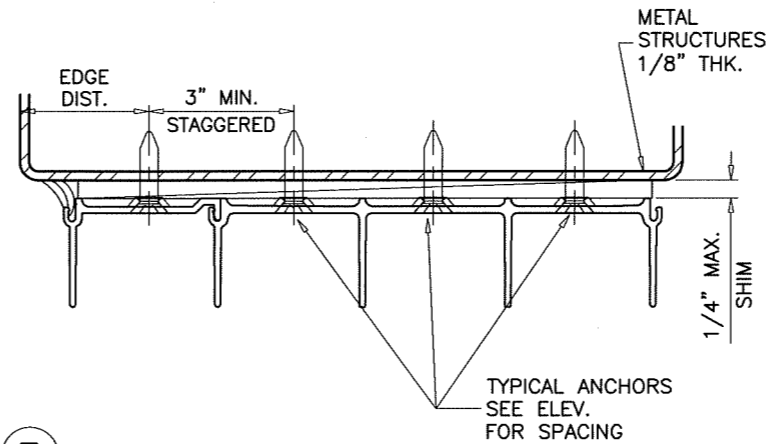
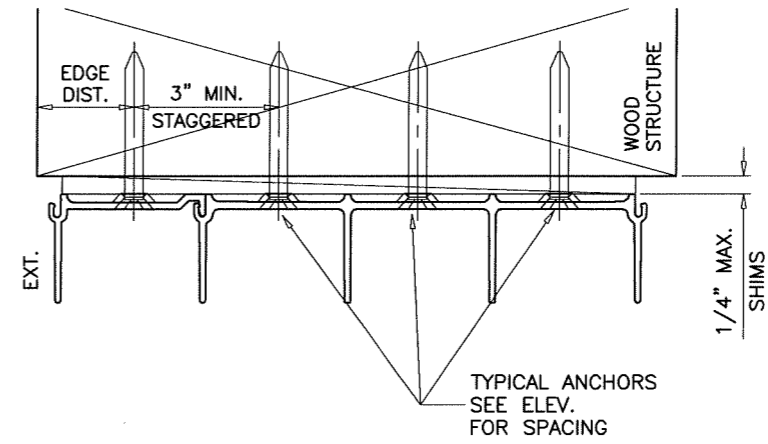
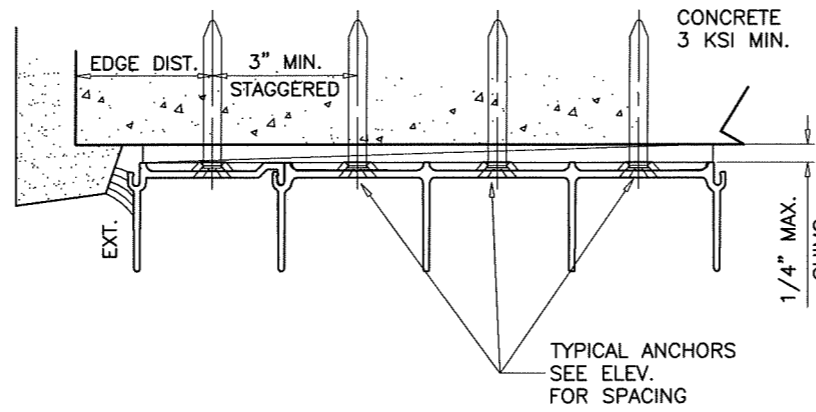
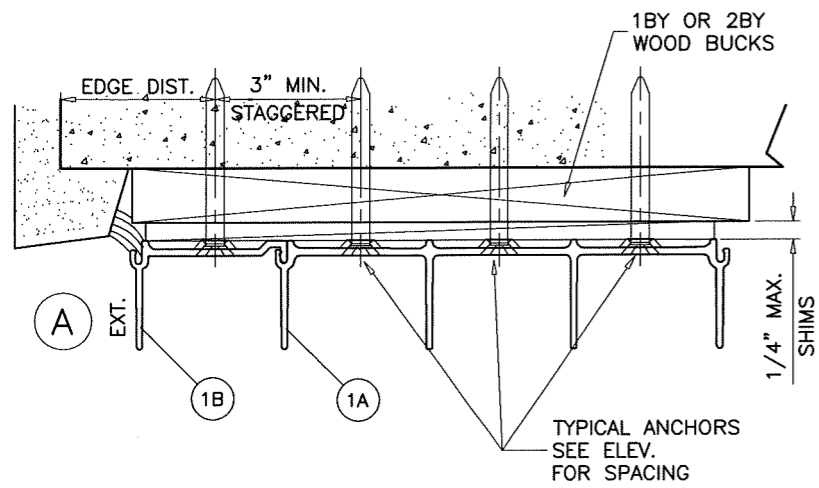

4 TRACK FRAMES
ANCHOR LOCATIONS

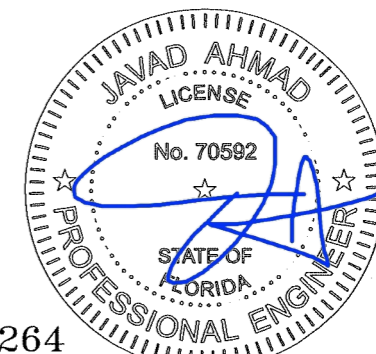

FL #22264

af c
AL-FAROOQ CORPORATION
 ENGINEERS & PRODUCT DEVELOPMENT
 9360 SUNSET DRIVE, SUITE 220
 MIAMI, FLORIDA 33173 (C.A.N. 3538)
 TEL (305) 264-8100 FAX (305) 262-6978
 COMP-ANL W17-25CCD

SERIES 44 ALUMINUM SLIDING GLASS DOOR (S.M.I.)
CRAWFORD GLASS DOOR COMPANY, INC.
 3301 S.W. 13TH DRIVE, SUITE B
 DEERFIELD BEACH, FL. 33442-8101
 TEL. (954) 480-6820 FAX. (954) 480-6814

revisions:	no.	date	description

date: 03-03-17
 scale: 3/8" = 1"
 dr. by: TARIQ
 chk. by:

drawing no.
W17-25

sheet 12 of 15

ITEM NO.	PART NUMBER	QUANTITY	DESCRIPTION	MATERIAL	MANF./SUPPLIER/REMARKS
1	120	1	FRAME HEAD (2 TRACK)	6063-T6	-
1A	130	1	FRAME HEAD (3 TRACK)	6063-T6	-
1B	110	1	HEAD EXTENSION (4 TRACK)	6063-T6	-
2	222A	1	FRAME SILL (2 TRACK)	6063-T6	-
2A	232A	1	FRAME SILL (3 TRACK)	6005-T6	-
2B	211	1	SILL EXTENSION (4 TRACK)	6005-T6	-
2C	201	AS REQD.	SILL EXTENSION (OPTIONAL)	6005-T6	-
3	321	2	FRAME JAMB (2 TRACK)	6063-T6	-
3A	331	2	FRAME JAMB (3 TRACK)	6063-T6	-
3B	311	2	JAMB EXTENSION (4 TRACK)	6063-T6	-
4	501	1/MOV. PANEL	MOVING HORIZ. BOTT. RAIL	6063-T6	-
5	500	1/FIX. PANEL	FIXED HORIZ. BOTT. RAIL	6063-T6	-
6	401	1/ PANEL	TOP RAIL	6063-T6	-
7	402	1/ PANEL	TOP RAIL CAP	6063-T6	-
7A	402 MOD.	-	HEAD BRUSH	6063-T6	AT MOVING PANEL ENDS
8	641	1	JAMB FIX. STILE	6063-T6	-
8A	621	1	JAMB MOV. STILE	6063-T6	-
9	631	1/ PANEL	INTERIOR INTERLOCK	6063-T6	-
10	633	1/ PANEL	EXTERIOR INTERLOCK	6063-T6	-
11	613	1	MALE ASTRAGAL STILE	6063-T6	-
12	623	1	FEMALE ASTRAGAL STILE	6063-T6	-
12A	642	1	FEMALE ASTRAGAL STILE	6063-T6	-
13	253	1	THRESHOLD COVER	6063-T6	-
14	250	-	FIX. PANEL SEAT	6063-T6	-
15	3016	AS REQD.	BULB GASKET	VINYL	MELTPOINT PLASTICS
16	371	-	JAMB REINFORCING	6063-T5	1/8" X 1-3/4"
18	145L	AS REQD.	GLAZING GASKET	VINYL	NORTH GEORGIA EXTRUDERS
19	WVC3068	-	BULB W'STRIPPING	VINYL	WIBORG
20	43622-270	AS REQD.	TOP RAIL W'STRIPPING	PILE	AMESBURY
21	43634-270	AS REQD.	SILL & SILL COVER W'STRIPPING	PILE	AMESBURY
22	43626-270	AS REQD.	VERTICAL W'STRIPPING	PILE	AMESBURY
26	200	AS REQD.	FRAME SILL NOSE (OPTIONAL)	6063-T5	-
27	#10 X 1/2"	1/ CORNER	TOP RAIL COVER ASSY. SCREWS	ST/ST	-
28	#12 X 1"	1/ CORNER	PANEL ASSY. SCREWS	ST/ST	-
29	5433925	2/MOV. PANEL	TANDEM WHEEL ASSEMBLY	ST/ST	ROCKWELL
30	70938878	1	DUAL POINT LOCK	ST/ST	ROCKWELL
30A	MS1847	1	DUAL POINT LOCK	ST/ST	ADAMS RITE

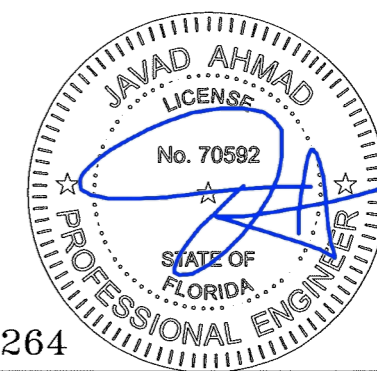

FL #22264



AL-FAROOQ CORPORATION
 ENGINEERS & PRODUCT DEVELOPMENT
 9360 SUNSET DRIVE, SUITE 220
 MIAMI, FLORIDA 33173 (C.A.N. 3538)
 TEL. (305) 264-8100 FAX. (305) 262-6978
 COMP-ANL\W17-25CGD

SERIES 44 ALUMINUM SLIDING GLASS DOOR (S.M.I.)

CRAWFORD GLASS DOOR COMPANY, INC.
 3301 S.W. 13TH DRIVE, SUITE B
 DEERFIELD BEACH, FL. 33442-8101
 TEL. (954) 480-6820 FAX. (954) 480-6814

no	date	by description

date: 03-03-17
 scale: 3/8" = 1"
 dr. by: TARIQ
 chk. by:

drawing no.
W17-25
 sheet 13 of 15

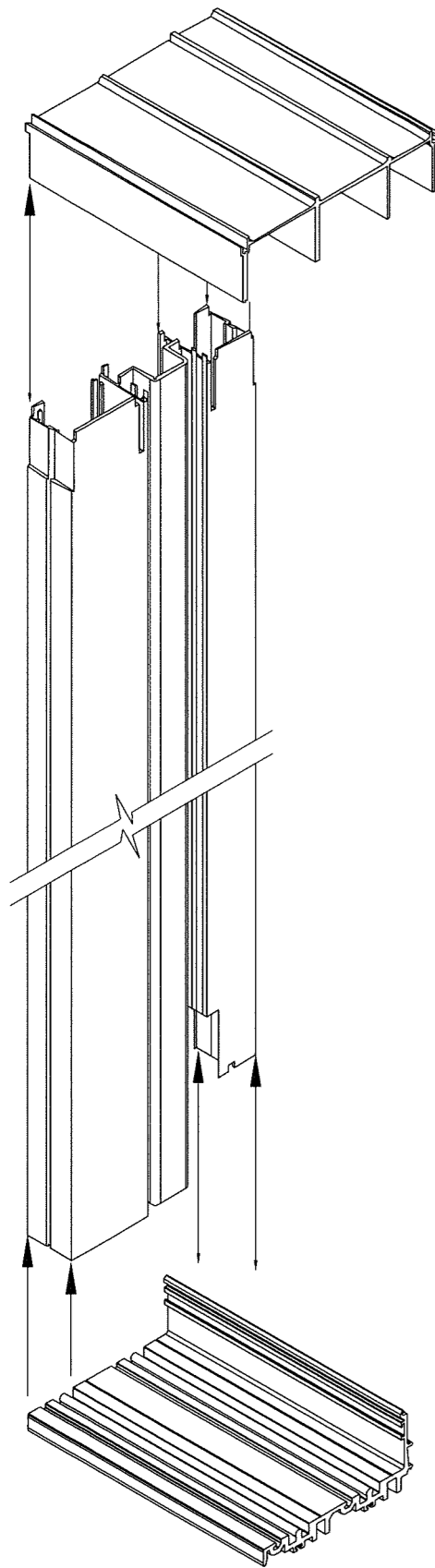

FRAME CORNER ASSEMBLY

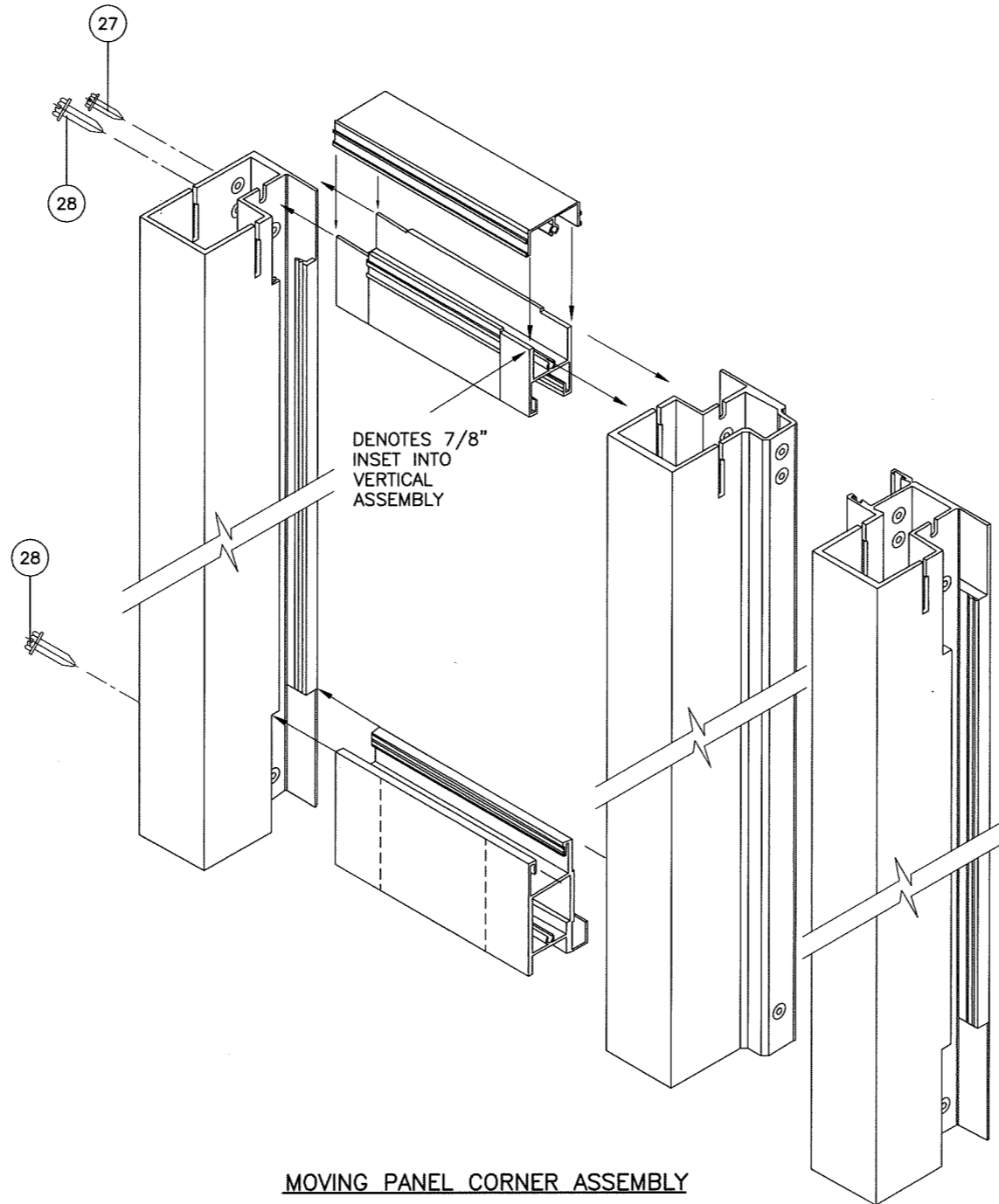

MOVING PANEL CORNER ASSEMBLY

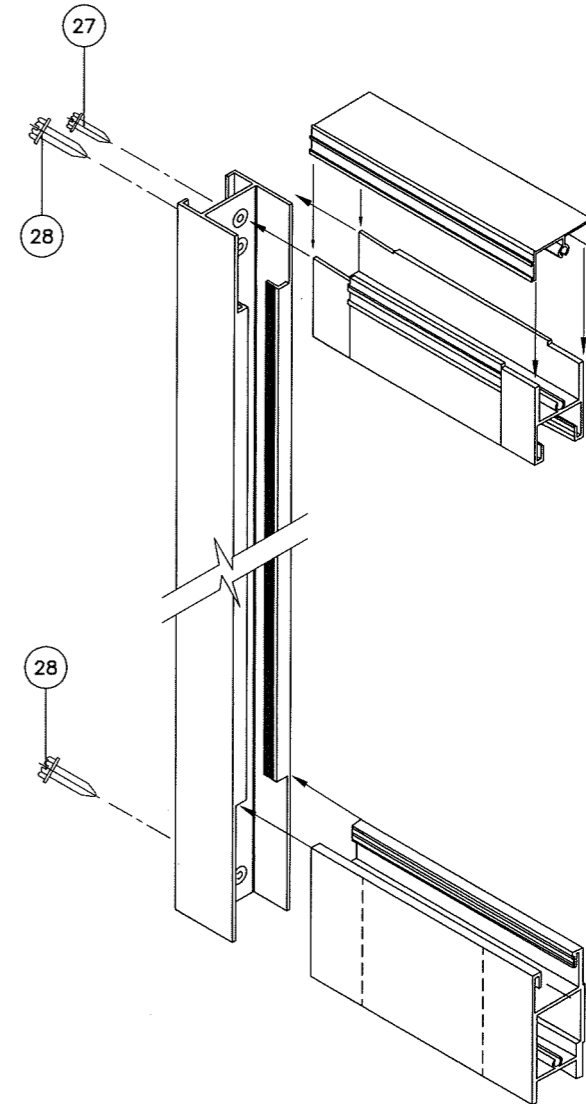

FIXED PANEL CORNER ASSEMBLY

SEALANT:

ALL JOINTS AND FRAME CONNECTIONS SEALED WITH TREMCO #116 VULKEM URETHANE ONE PART SEALANT.

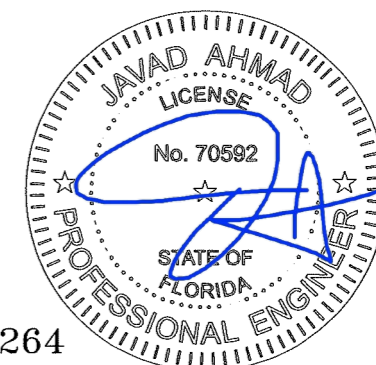

FL #22264

Sealed: 2/19/2018

af c
AL-FAROOQ CORPORATION
 ENGINEERS & PRODUCT DEVELOPMENT
 9360 SUNSET DRIVE, SUITE 220
 MIAMI, FLORIDA 33173 (C.A.N. 3538)
 TEL. (305) 264-8100 FAX. (305) 262-6978
 COMP-ANL\W17-25CGD

SERIES 44 ALUMINUM SLIDING GLASS DOOR (S.M.I.)
CRAWFORD GLASS DOOR COMPANY, INC.
 3301 S.W. 13TH DRIVE, SUITE B
 DEERFIELD BEACH, FL. 33442-8101
 TEL. (954) 480-6820 FAX. (954) 480-6814

revisions:	no	date	by	description

date: 03-03-17
 scale: 3/8" = 1"
 dr. by: TARIQ
 chk. by:

drawing no.
W17-25

sheet 15 of 15