

REVISIONS			
REV	DESCRIPTION	DATE	APPROVED

NOTES:

1. THE PRODUCT SHOWN HEREIN IS DESIGNED AND MANUFACTURED TO COMPLY WITH REQUIREMENTS OF THE FLORIDA BUILDING CODE INCLUDING THE HVHZ.
2. WOOD FRAMING TO BE DESIGNED AND ANCHORED TO PROPERLY TRANSFER ALL LOADS TO STRUCTURE. FRAMING IS THE RESPONSIBILITY OF THE ARCHITECT OR ENGINEER OF RECORD.
3. ALLOWABLE STRESS INCREASE OF 7/3 WAS NOT USED IN THE DESIGN OF THE PRODUCT SHOWN HEREIN. WIND LOAD DURATION FACTOR $C_d=1.6$ WAS USED FOR WOOD ANCHOR CALCULATIONS.
4. APPROVED IMPACT PROTECTIVE SYSTEM IS NOT REQUIRED FOR THIS PRODUCT IN WIND BORNE DEBRIS REGIONS.
5. DESIGN PRESSURE AND INSTALLATION DETAILS SHOWN IN THIS DOCUMENT APPLY ONLY TO MULLION. WINDOWS MUST BE APPROVED UNDER SEPARATE APPROVAL.
6. SINGLE WINDOWS TO BE MULLED ARE NOT LIMITED TO THOSE SHOWN IN THIS DRAWING. WINDOWS ATTACHED TO MULLION MUST HAVE SEPARATE APPROVAL.
7. DESIGN PRESSURE OF MULLED UNIT SHALL BE CONTROLLED BY THE LESSER DESIGN PRESSURE OF THE MULLION OR THE INDIVIDUAL WINDOW OR DOOR UNIT.
8. UNITS MAY BE MULLED TOGETHER INDEFINITELY AS LONG AS SINGLE UNIT WIDTH AND HEIGHT ARE NOT EXCEEDED AND MULLION IS ANCHORED AS SHOWN HEREIN.
9. MULLION VERTICAL INSTALLATION IS SHOWN, MULLION MAY BE USED IN HORIZONTAL APPLICATIONS AS LONG AS DIMENSIONS INDICATED HEREIN ARE NOT EXCEEDED AND MULLION IS ANCHORED ACCORDING TO THIS DOCUMENT.

ANCHORING NOTES:

1. FOR ANCHORING INTO WOOD FRAMING OR 2X BUCK USE #10 WOOD SCREW WITH SUFFICIENT LENGTH TO ACHIEVE A 1 3/8" MINIMUM EMBEDMENT. LOCATE ANCHORS AS SHOWN IN INSTALLATION DETAILS.
2. FOR ANCHORING INTO CONCRETE USE 3/16" TAPCON WITH SUFFICIENT LENGTH TO ACHIEVE A 1 3/4" MINIMUM EMBEDMENT WITH 2 1/2" MINIMUM EDGE DISTANCE. LOCATE ANCHORS AS SHOWN IN INSTALLATION DETAILS.
3. FOR ANCHORING INTO METAL STRUCTURE USE #10 SMS OR SELF DRILLING SCREWS WITH SUFFICIENT LENGTH TO ACHIEVE 3 THREADS MINIMUM BEYOND STRUCTURE INTERIOR WALL. LOCATE ANCHORS AS SHOWN IN INSTALLATION DETAILS.
4. FOR ATTACHING WINDOW UNITS TO MULLION USE #10 SELF DRILLING SCREWS WITH SUFFICIENT LENGTH TO ACHIEVE A MINIMUM EMBEDMENT OF THREE THREADS PAST THE MULLION WALL. LOCATE SCREWS IN ACCORDANCE WITH WINDOW ANCHORING SCHEDULE AS SHOWN IN WINDOW SEPARATE APPROVAL.
5. ALL FASTENERS TO BE CORROSION RESISTANT.
6. INSTALLATION ANCHORS SHALL BE INSTALLED IN ACCORDANCE WITH ANCHOR MANUFACTURER'S INSTALLATION INSTRUCTIONS, AND ANCHORS SHALL NOT BE USED IN SUBSTRATES WITH STRENGTHS LESS THAN THE MINIMUM STRENGTH SPECIFIED BELOW:
 - A. WOOD – MINIMUM SPECIFIC GRAVITY OF $G=0.42$
 - B. CONCRETE – MINIMUM COMPRESSIVE STRENGTH OF 3,200 PSI.
 - C. MASONRY – STRENGTH CONFORMANCE TO ASTM C-90, GRADE N, TYPE 1 (OR GREATER).
 - D. METAL STRUCTURE: STEEL 18GA, 33KSI OR ALUMINUM 6063-T5 1/8" THICK MINIMUM
7. TO ATTACH MULLION TO CLIP USE (4) #10 x 1 1/4" SELF DRILLING SCREWS PER CLIP. SCREWS MUST BE FIELD INSTALLED.

SIGNED: 01/17/2017

TABLE OF CONTENTS	
SHEET NO.	DESCRIPTION
1	NOTES
2	APPROVED CONFIGURATIONS AND CHART
3 – 6	INSTALLATION DETAILS
7	COMPONENTS

		EASTERN ARCHITECTURAL SYSTEMS A DIVISION OF EASTERN METAL SUPPLY 16341 DOMESTIC AVE FORT MYERS, FL 33912 800-432-2204	
176 HVHZ X-MULLION, LARGE AND SMALL MISSILE IMPACT NOTES			
DRAWN: V.L.		DWG NO. 08-02951	
SCALE NTS		DATE 09/21/16	
		SHEET 1 OF 7	

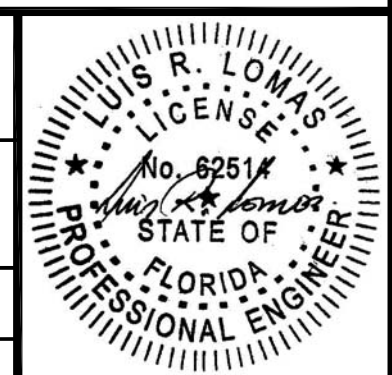

REVISIONS			
REV	DESCRIPTION	DATE	APPROVED

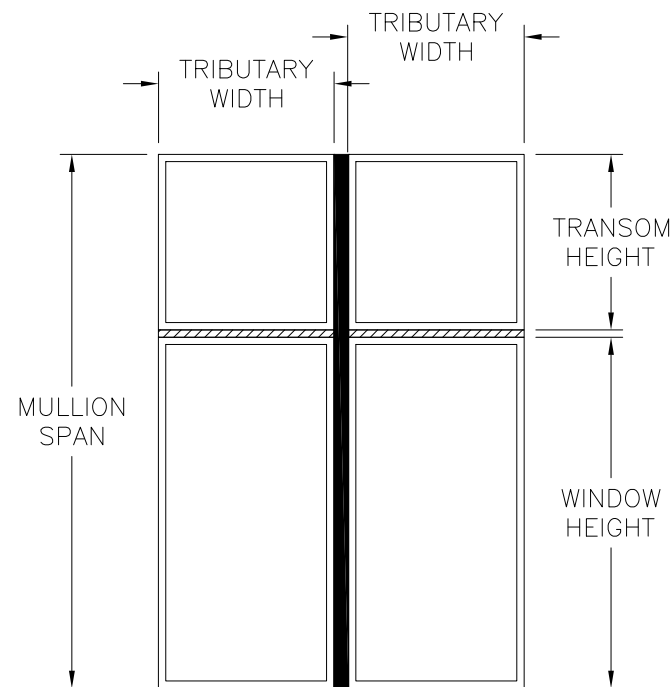

VERTICAL MULLION
TWIN UNITS WITH TWIN TRANSOMS
SEE CHARTS #1, #2, #3, & #4 FOR RATINGS

CHART #1
Maximum design pressure chart (psf)
Units with 18" transom

Height (in)		Tributary width (in)						
Window	Transom	36.00	42.00	48.00	54.00	60.00	66.00	72.00
36.00	18.00	150.0	150.0	150.0	150.0	142.7	132.1	123.0
42.00	18.00	150.0	150.0	147.3	134.9	124.4	115.5	107.7
48.00	18.00	150.0	142.0	128.9	118.5	109.6	101.9	95.3
54.00	18.00	138.3	123.3	112.4	104.3	97.3	90.7	84.9
60.00	18.00	105.9	94.2	85.7	79.4	74.5	70.6	67.0
66.00	18.00	82.7	73.5	66.7	61.6	57.7	54.7	52.2
72.00	18.00	65.7	58.3	52.8	48.7	45.5	43.1	41.1
78.00	18.00	53.0	46.9	42.5	39.1	36.5	34.4	32.8
84.00	18.00	43.4	38.3	34.6	31.8	29.6	27.9	26.5

IMPACT RATED UP TO WIND ZONE 4 AND HVHZ

CHART #2
Maximum design pressure chart (psf)
Units with 24" transom

Height (in)		Tributary width (in)						
Window	Transom	36.00	42.00	48.00	54.00	60.00	66.00	72.00
36.00	24.00	150.0	150.0	150.0	138.4	127.4	118.0	109.9
42.00	24.00	150.0	146.6	133.2	122.1	112.6	104.6	97.6
48.00	24.00	142.4	125.8	113.6	103.9	95.8	88.8	82.8
54.00	24.00	109.5	96.7	87.2	80.1	74.2	69.2	64.8
60.00	24.00	85.7	75.7	68.2	62.6	58.2	54.5	51.3
66.00	24.00	68.3	60.2	54.2	49.7	46.2	43.4	41.0
72.00	24.00	55.2	48.6	43.7	40.0	37.2	34.9	33.0
78.00	24.00	45.1	39.7	35.7	32.7	30.3	28.4	26.8
84.00	24.00	37.4	32.9	29.5	27.0	25.0	23.4	22.1

IMPACT RATED UP TO WIND ZONE 4 AND HVHZ

CHART #3
Maximum design pressure chart (psf)
Units with 30" transom

Height (in)		Tributary width (in)						
Window	Transom	36.00	42.00	48.00	54.00	60.00	66.00	72.00
36.00	30.00	150.0	149.3	135.5	123.9	114.2	105.9	98.8
42.00	30.00	145.1	127.5	114.0	103.1	94.1	86.5	80.1
48.00	30.00	112.1	98.4	88.3	80.2	73.5	67.8	63.0
54.00	30.00	88.1	77.3	69.3	63.2	58.2	53.9	50.2
60.00	30.00	70.3	61.7	55.3	50.4	46.5	43.3	40.5
66.00	30.00	56.9	50.0	44.8	40.8	37.6	35.1	32.9
72.00	30.00	46.7	40.9	36.7	33.4	30.8	28.7	27.0
78.00	30.00	38.7	33.9	30.3	27.6	25.5	23.7	22.3
84.00	30.00	32.4	28.4	25.4	23.1	21.3	19.8	18.6

IMPACT RATED UP TO WIND ZONE 4 AND HVHZ

CHART #4
Maximum design pressure chart (psf)
Units with 36" transom

Height (in)		Tributary width (in)						
Window	Transom	36.00	42.00	48.00	54.00	60.00	66.00	72.00
36.00	36.00	146.1	128.1	114.0	102.7	93.5	85.7	79.2
42.00	36.00	113.4	99.5	88.7	80.1	73.0	67.0	62.0
48.00	36.00	89.6	78.5	70.1	63.5	58.0	53.4	49.5
54.00	36.00	71.8	62.8	56.1	50.9	46.7	43.1	40.0
60.00	36.00	58.3	51.0	45.5	41.3	37.9	35.2	32.7
66.00	36.00	47.9	41.9	37.4	33.9	31.1	28.9	27.0
72.00	36.00	39.8	34.8	31.0	28.1	25.8	24.0	22.4
78.00	36.00	33.3	29.1	26.0	23.5	21.6	20.1	18.8
84.00	36.00	28.2	24.6	21.9	19.9	18.3	16.9	-

IMPACT RATED UP TO WIND ZONE 4 AND HVHZ

DESIGN PRESSURE TABLE INSTRUCTIONS:

1. DEFINE REQUIRED DESIGN LOAD PER FLORIDA BUILDING CODE CHAPTER 16.
2. DETERMINE TRIBUTARY WIDTH AND MULLION SPAN BASED ON PRODUCT TO BE INSTALLED. SEE FORMULA FOR TRIBUTARY WIDTH.
3. LOCATE MULLION SPAN (UNIT HEIGHT) AND TRIBUTARY WIDTH. AT THE INTERSECTION OF ROW AND COLUMN CONTAINING THE MULLION SPAN AND TRIBUTARY WIDTH RESPECTIVELY IS THE MULLION RATING FOR PRODUCT IN STEP 2. MULLION RATING MUST BE EQUAL OR GREATER THAN REQUIRED DESIGN PRESSURE OBTAINED IN STEP 1.

$$\text{TRIBUTARY WIDTH} = \frac{W1 + W2}{2}$$

SIGNED: 01/17/2017

 <p>Eastern ARCHITECTURAL SYSTEMS ALUMINUM AND VINYL IMPACT WINDOWS AND DOORS</p>	<p>EASTERN ARCHITECTURAL SYSTEMS A DIVISION OF EASTERN METAL SUPPLY</p> <p>16341 DOMESTIC AVE FORT MYERS, FL 33912 800-432-2204</p>	
	<p>176 HVHZ X-MULLION, LARGE AND SMALL MISSILE IMPACT APPROVED CONFIGURATIONS & CHART</p>	
<p>DRAWN: V.L.</p>	<p>DWG NO. 08-02951</p>	<p>REV -</p>
<p>SCALE NTS</p>	<p>DATE 09/21/16</p>	<p>SHEET 2 OF 7</p>



REVISIONS			
REV	DESCRIPTION	DATE	APPROVED

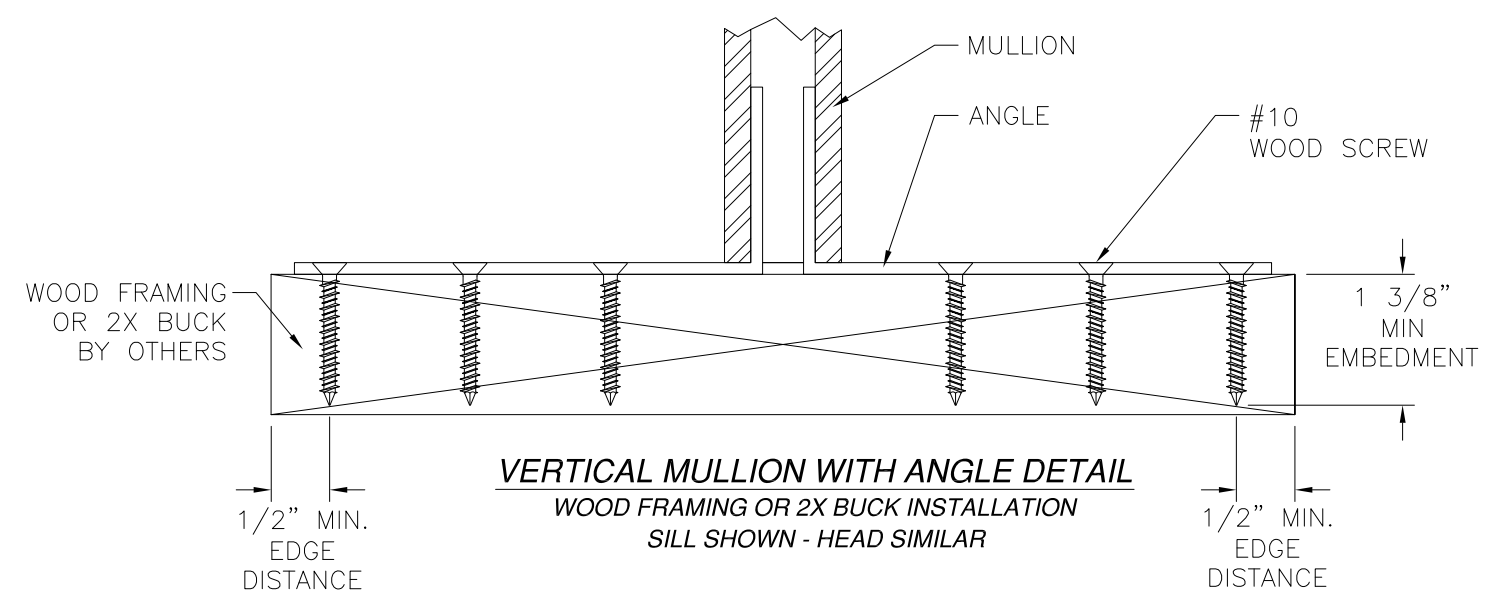
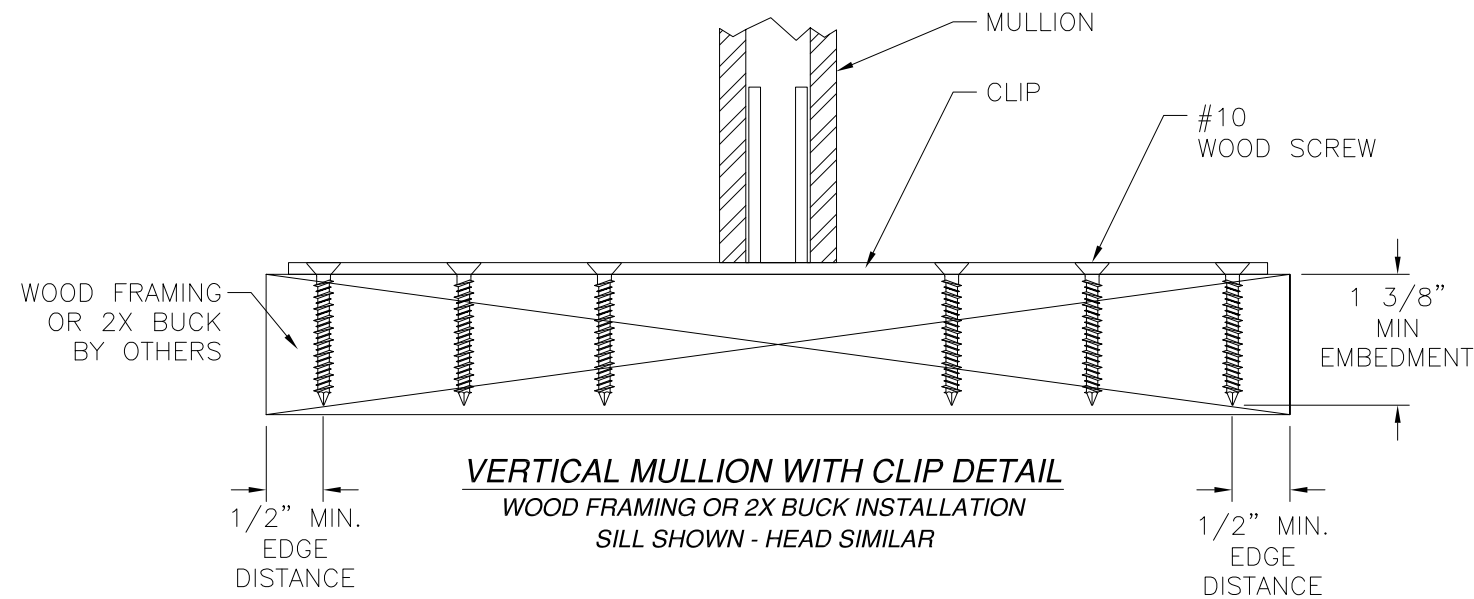
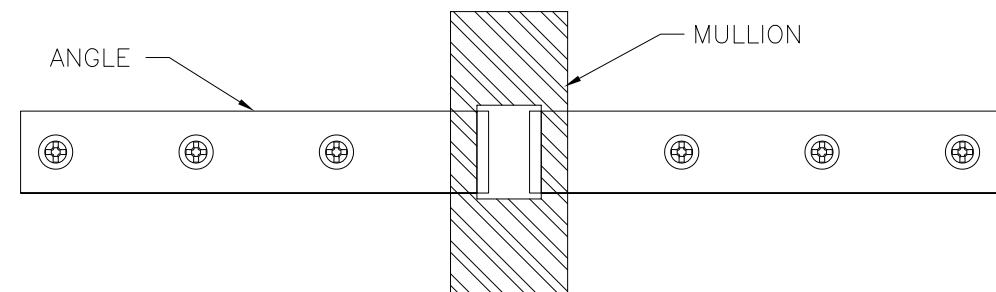
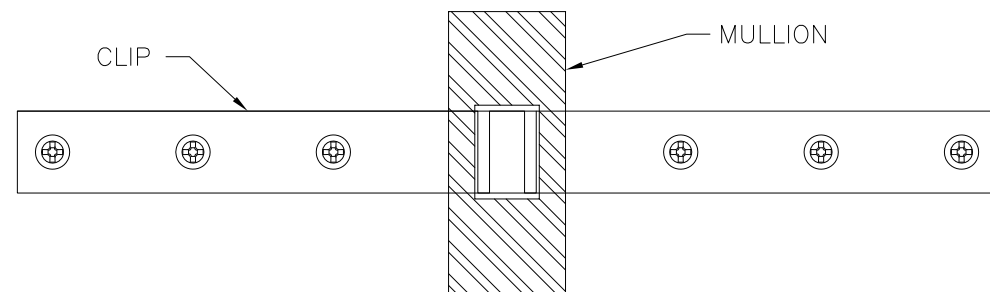

SIGNED: 01/17/2017

 Eastern ARCHITECTURAL SYSTEMS ALUMINUM AND VINYL IMPACT WINDOWS AND DOORS	EASTERN ARCHITECTURAL SYSTEMS A DIVISION OF EASTERN METAL SUPPLY 16341 DOMESTIC AVE FORT MYERS, FL 33912 800-432-2204	
	176 HVHZ X-MULLION, LARGE AND SMALL MISSILE IMPACT INSTALLATION DETAILS	
DRAWN: V.L.	DWG NO. 08-02951	REV -
SCALE NTS	DATE 09/21/16	SHEET 3 OF 7

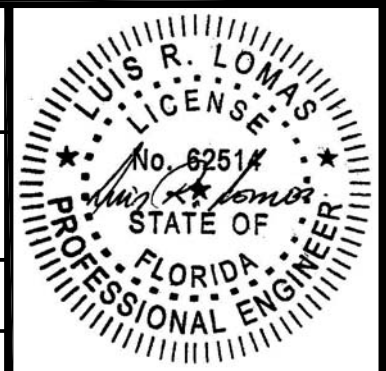

REVISIONS			
REV	DESCRIPTION	DATE	APPROVED

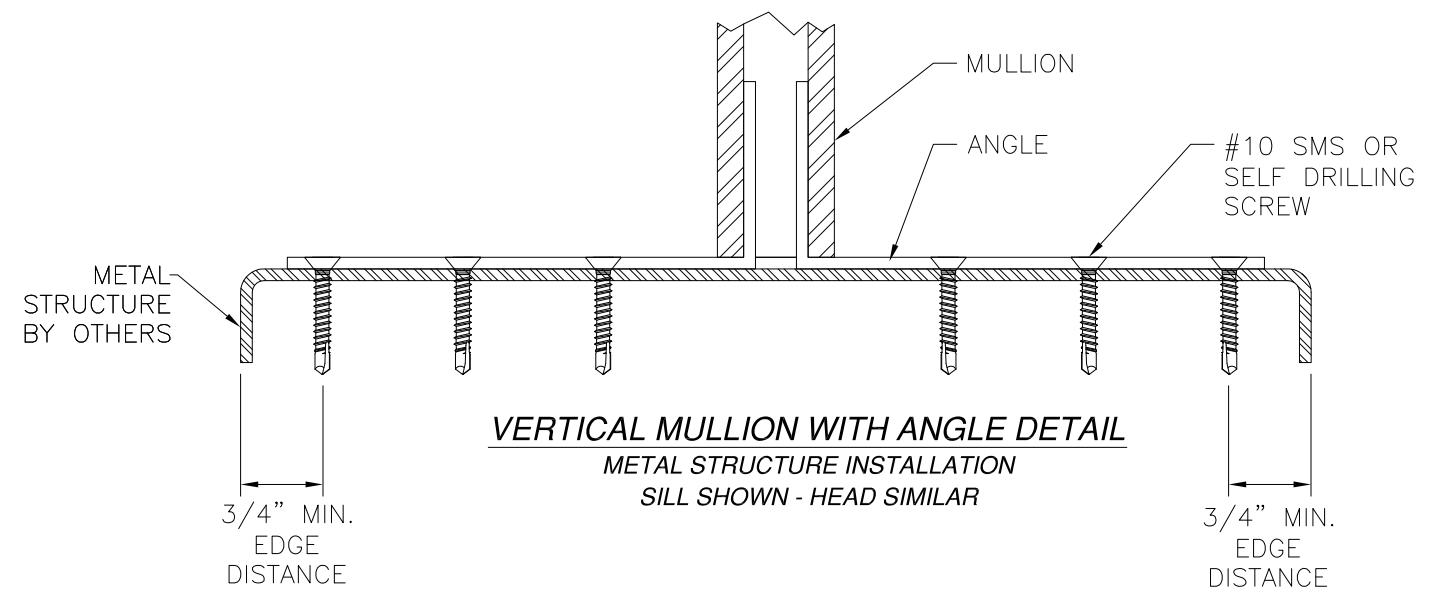
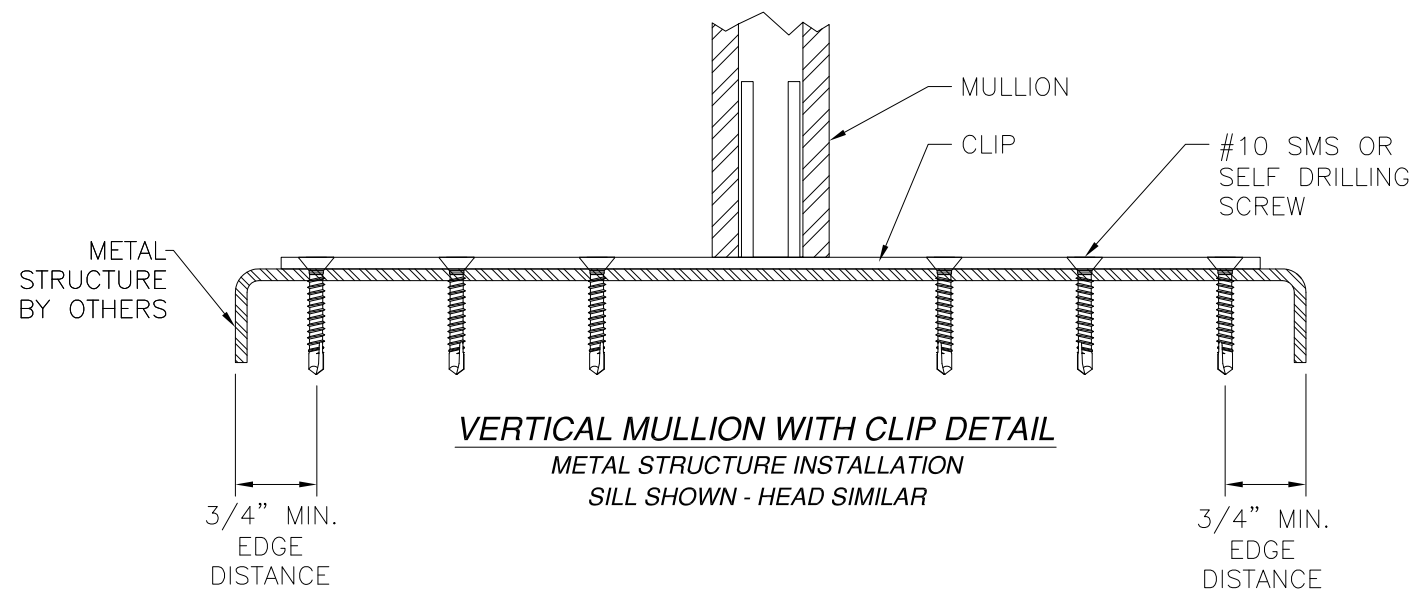
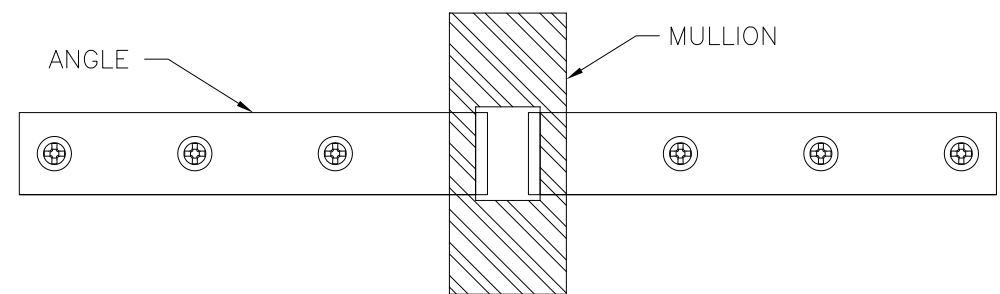
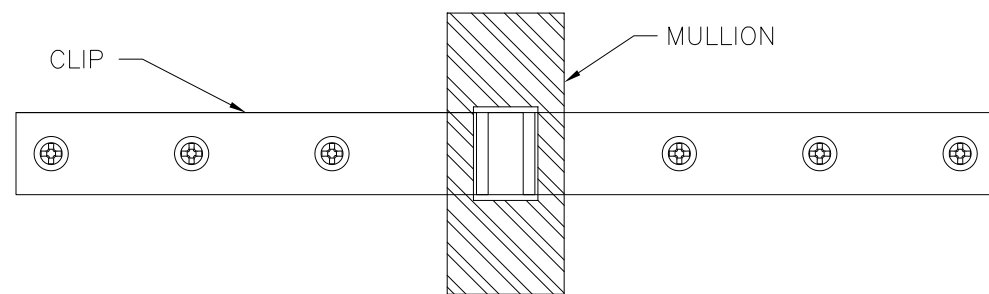

SIGNED: 01/17/2017

Eastern
ARCHITECTURAL SYSTEMS
ALUMINUM AND VINYL
IMPACT WINDOWS AND DOORS

EASTERN ARCHITECTURAL SYSTEMS
A DIVISION OF
EASTERN METAL SUPPLY
16341 DOMESTIC AVE
FORT MYERS, FL 33912
800-432-2204

176 HVHZ X-MULLION,
LARGE AND SMALL MISSILE IMPACT
INSTALLATION DETAILS

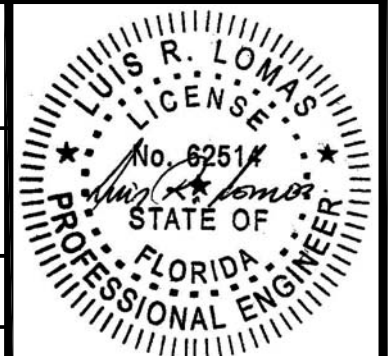

DRAWN: V.L.	DWG NO. 08-02951	REV -
SCALE NTS	DATE 09/21/16	SHEET 4 OF 7

REVISIONS			
REV	DESCRIPTION	DATE	APPROVED

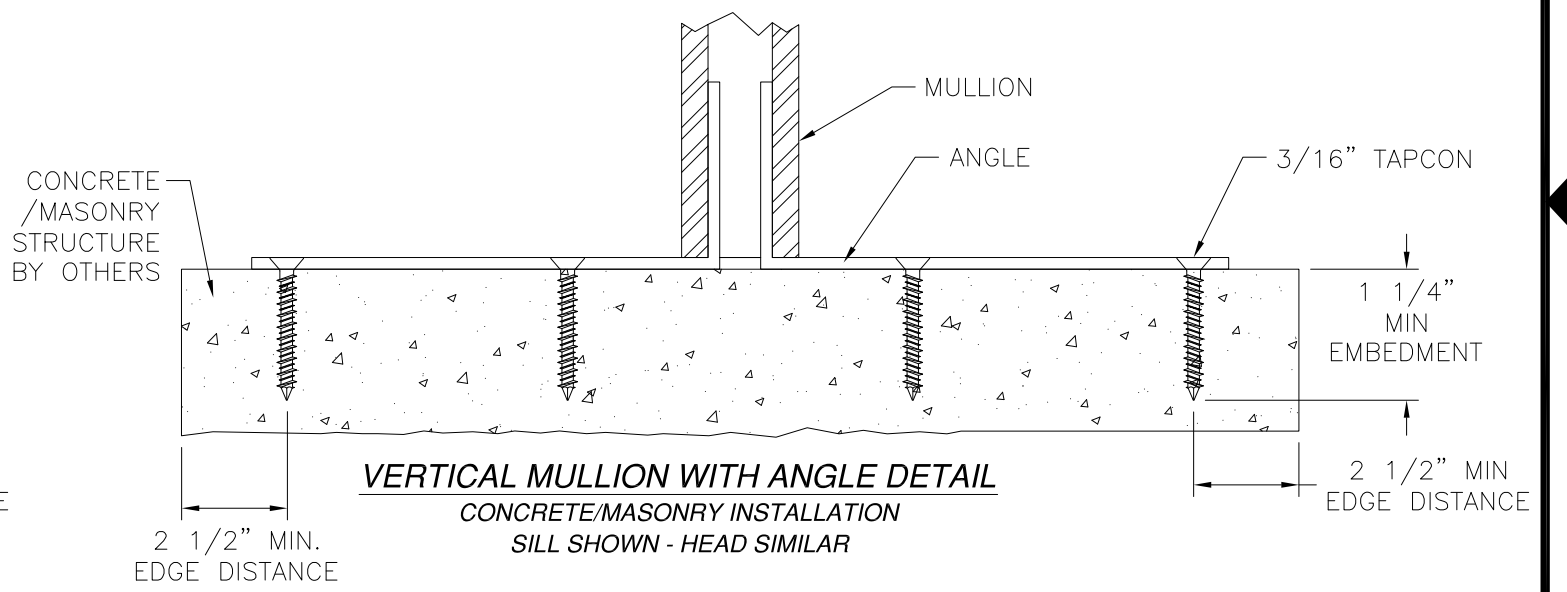
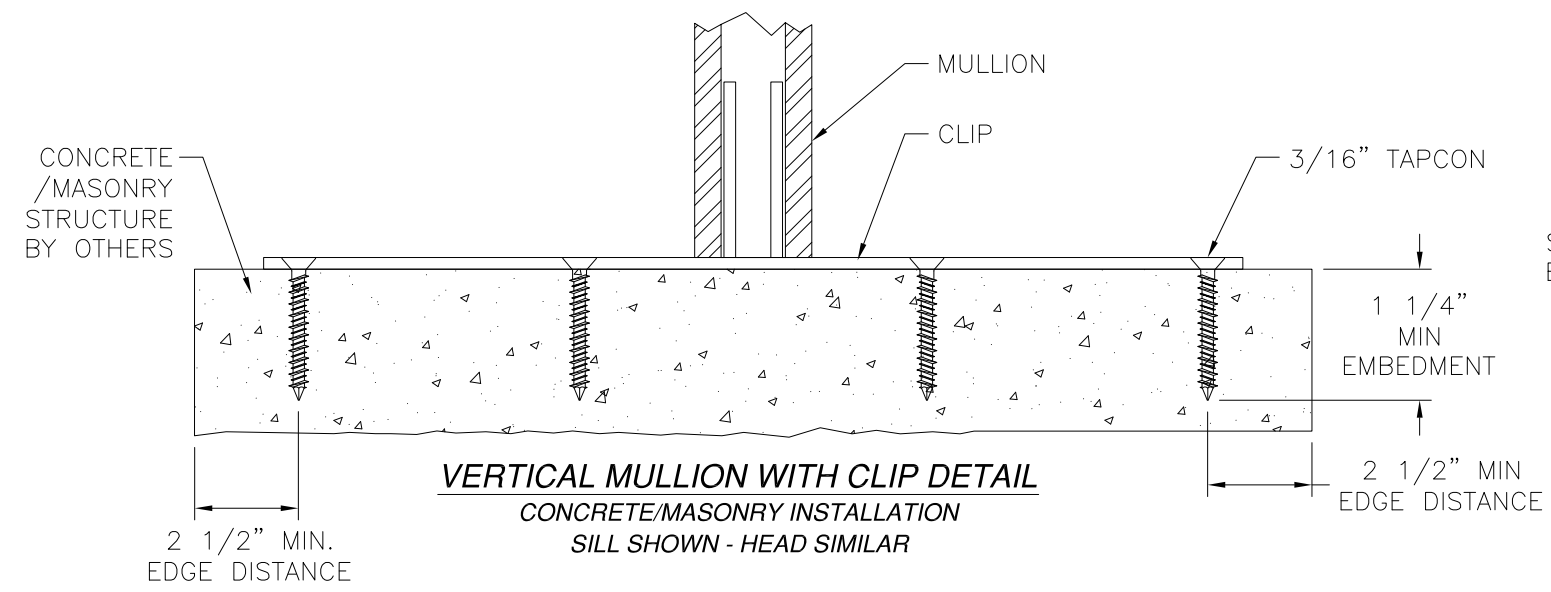
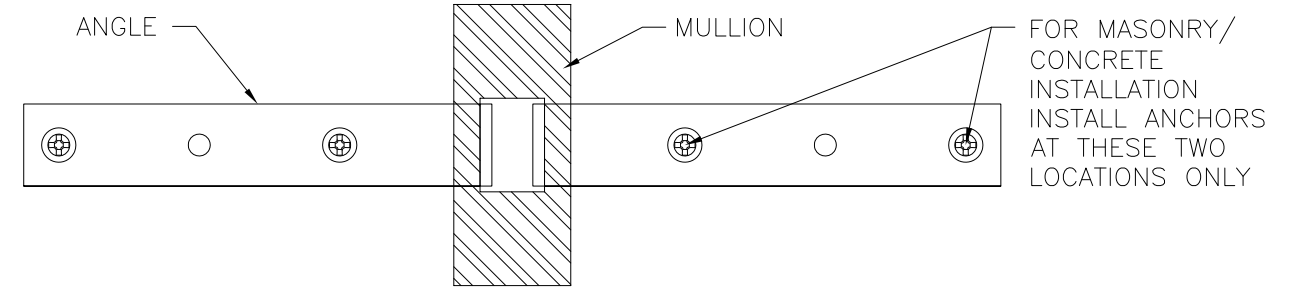
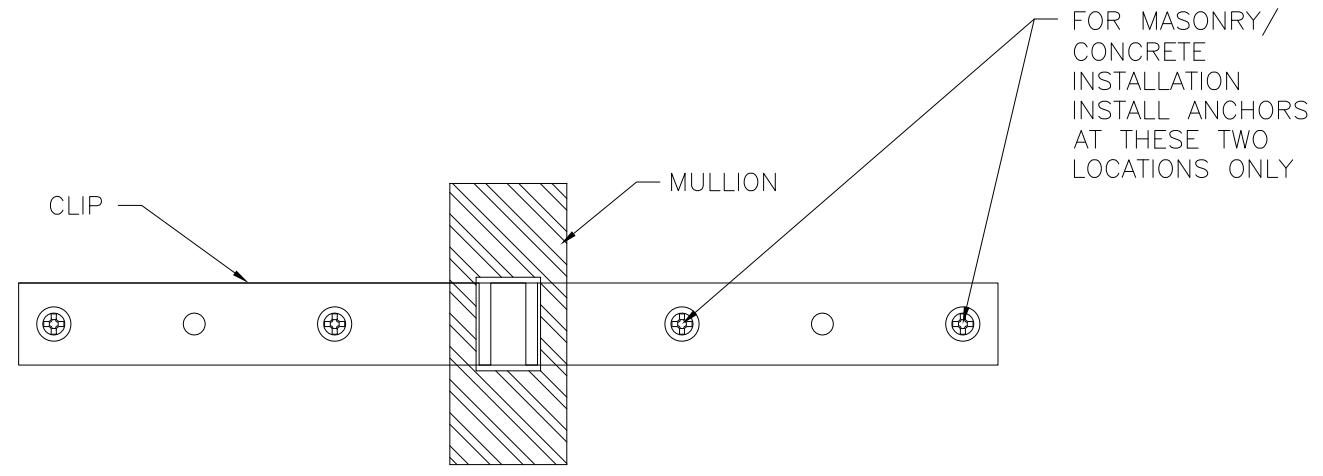

SIGNED: 01/17/2017

Eastern
ARCHITECTURAL SYSTEMS
ALUMINUM AND VINYL
IMPACT WINDOWS AND DOORS

EASTERN ARCHITECTURAL SYSTEMS
A DIVISION OF
EASTERN METAL SUPPLY
16341 DOMESTIC AVE
FORT MYERS, FL 33912
800-432-2204

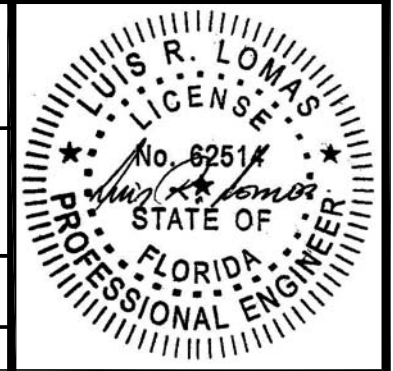

176 HVHZ X-MULLION,
LARGE AND SMALL MISSILE IMPACT
INSTALLATION DETAILS

DRAWN: V.L.	DWG NO. 08-02951	REV -
SCALE NTS	DATE 09/21/16	SHEET 5 OF 7

REVISIONS			
REV	DESCRIPTION	DATE	APPROVED

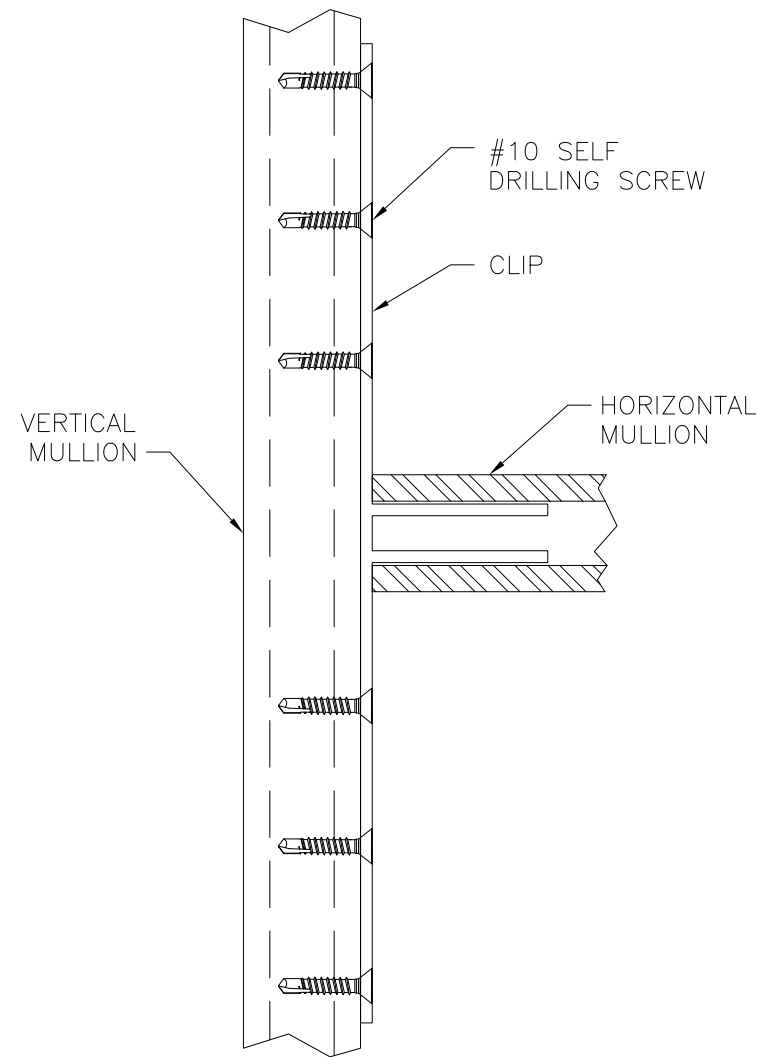
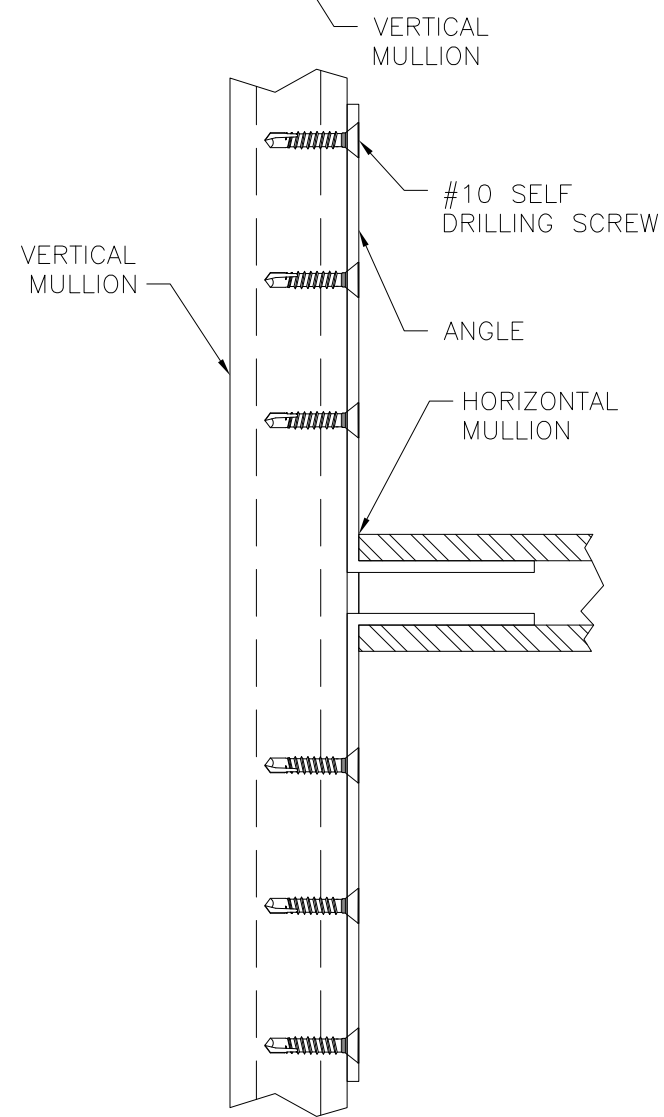
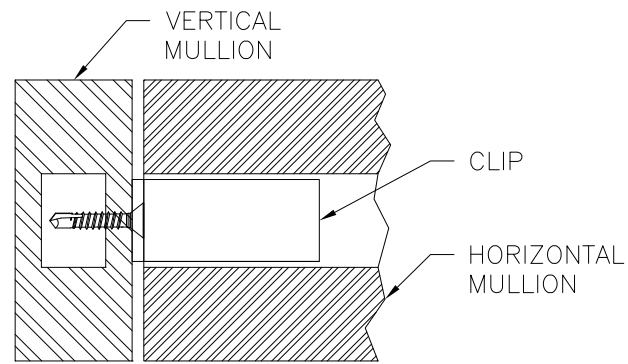
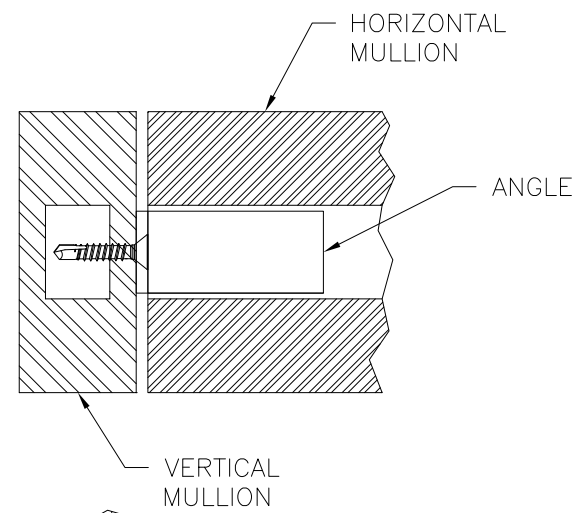

VERTICAL TO HORIZONTAL MULLION CONNECTION WITH ANGLE

VERTICAL TO HORIZONTAL MULLION CONNECTION WITH CLIP

SIGNED: 01/17/2017



EASTERN ARCHITECTURAL SYSTEMS
A DIVISION OF
EASTERN METAL SUPPLY
16341 DOMESTIC AVE
FORT MYERS, FL 33912
800-432-2204

176 HVHZ X-MULLION,
LARGE AND SMALL MISSILE IMPACT
INSTALLATION DETAILS

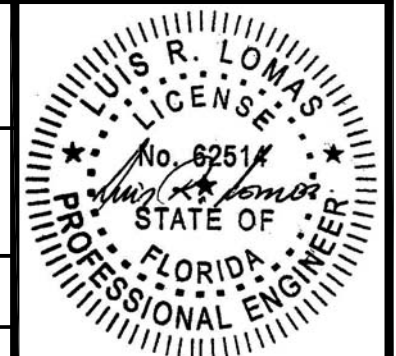

DRAWN: V.L.	DWG NO. 08-02951	REV -
SCALE NTS	DATE 09/21/16	SHEET 6 OF 7

BILL OF MATERIALS				
ITEM NO.:	PART NUMBER	DESCRIPTION	MANUFACTURER	MATERIAL
1	56372	H-CLIP	SAPA	ALUMINUM 6063-T6
2		ANGLE		ALUMINUM 6063-T6
3	56371	1 1/4" X 3" TUBE MULLION	SAPA	ALUMINUM 6063-T6

REVISIONS			
REV	DESCRIPTION	DATE	APPROVED

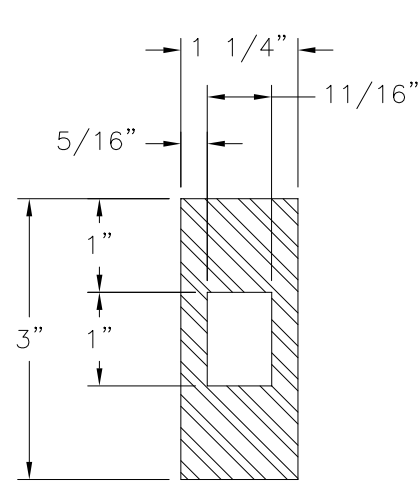

1 1/4"X3" TUBE MULLION
 ALUMINUM 6063-T6 .125" THICK
 EFFECTIVE MOMENT OF INERTIA: 2.9952 IN⁴
 SECTION MODULUS: 1.864 IN³

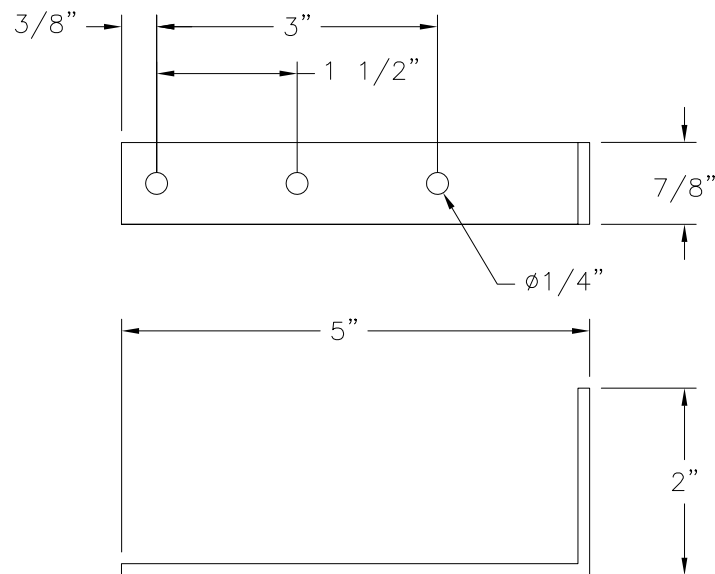

ANGLE
 ALUMINUM 6063-T6 .125" THICK

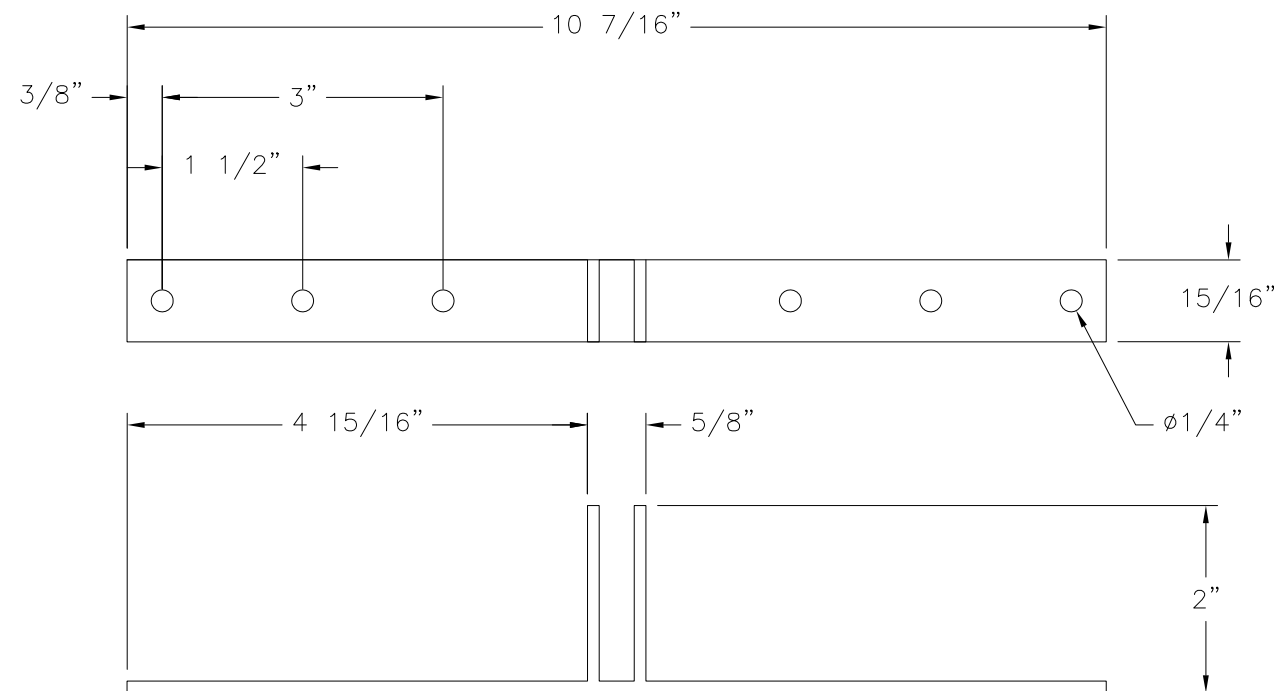

CLIP
 ALUMINUM 6063-T6 .125" THICK

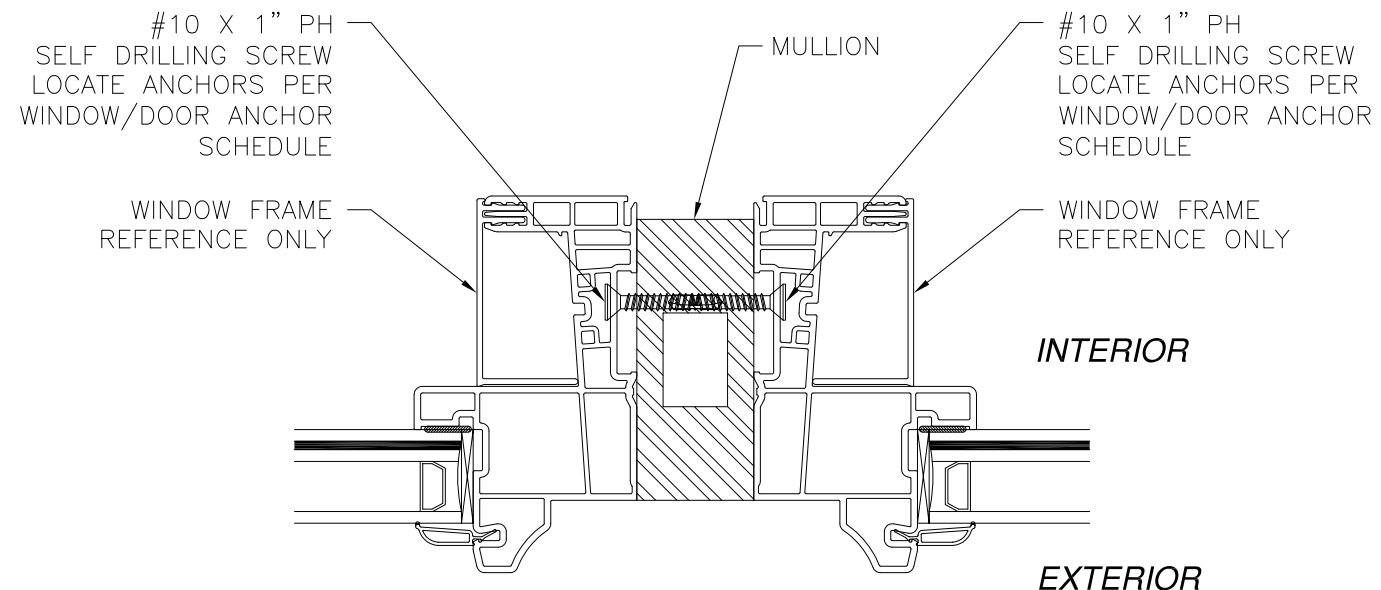

WINDOW TO MULLION INSTALLATION DETAIL
 WINDOW FRAME SHOWN FOR DETAIL PURPOSES ONLY
 MULLION IS NOT LIMITED TO THIS PRODUCT



EASTERN ARCHITECTURAL SYSTEMS
 A DIVISION OF
 EASTERN METAL SUPPLY
 16341 DOMESTIC AVE
 FORT MYERS, FL 33912
 800-432-2204

176 HVHZ X-MULLION,
 LARGE AND SMALL MISSILE IMPACT
 COMPONENTS

DRAWN: V.L.	DWG NO. 08-02951	REV -
SCALE NTS	DATE 09/21/16	SHEET 7 OF 7

SIGNED: 01/17/2017

