

Evaluation Report "Tee-Lock Panel" Metal Roof Assembly

Manufacturer:
Berridge Manufacturing Company
1720 Maury Road
Houston, TX 77026
(800) 231-8127

for

Florida Product Approval

FL 20321.3 R4

Florida Building Code 7th Edition (2020)

Method: 1 - D

Category: Roofing

Sub - Category: Metal Roofing

Product: "Tee-Lock" Roof Panel

Material: Aluminum

Panel Thickness: 0.032"

Panel Width: 18"

Support: Insulated Steel Deck

Prepared by:

James L. Buckner, P.E., S.E.C.B.
Florida Professional Engineer # 31242
Florida Evaluation ANE ID: 1916
Project Manager: Diana Galloway
Report No. 20-227-TL-A3S-ER
(Revises 17-128-TL-A3S-ER, FL20321.3 R2)
Date: 09 / 17 / 20

This item has been electronically signed and sealed by James L. Buckner, P.E., on this date using a Digital Signature. Printed copies of this document are not considered signed and sealed, and the signature must be verified on any electronic copies.

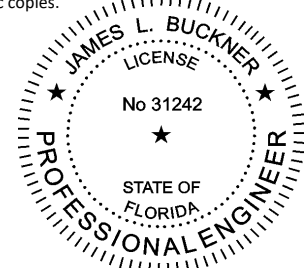

A handwritten signature in blue ink, appearing to read "James L. Buckner".

2020.10.15 19:45:20 -04'00'

Contents:

Evaluation Report Pages 1 – 8

Manufacturer:	Berridge Manufacturing Company 1720 Maury Road Houston, TX 77026 (800) 231-8127 www.berridge.com												
Product Name:	"Tee-Lock"												
Product Category:	Roofing												
Product Sub-Category	Metal Roofing												
Compliance Method:	State Product Approval Rule 61G20-3.005 (1) (d)												
Product/System Description:	"Tee-Lock" Standing Seam Roof Panel, 0.032" Aluminum tee rib roof panel restrained by panel clips, fastened into Steel Deck.												
Product Assembly as Evaluated:	Refer to Page 4 of this report for product assembly components/materials & standards: <table><tr><td>1. Roof Panel</td><td>"Tee-Lock"</td></tr><tr><td>2. Panel Clip</td><td>Tee-Lock panel clip</td></tr><tr><td>3. Fasteners</td><td>#14 w/3" steel disk</td></tr><tr><td>4. Underlayment:</td><td>Per Page 5</td></tr><tr><td>5. Bearing Plate</td><td>6" x 6"</td></tr><tr><td>6. Insulation (Optional):</td><td>Rigid Insulation Board, 4" – 6"</td></tr></table>	1. Roof Panel	"Tee-Lock"	2. Panel Clip	Tee-Lock panel clip	3. Fasteners	#14 w/3" steel disk	4. Underlayment:	Per Page 5	5. Bearing Plate	6" x 6"	6. Insulation (Optional):	Rigid Insulation Board, 4" – 6"
1. Roof Panel	"Tee-Lock"												
2. Panel Clip	Tee-Lock panel clip												
3. Fasteners	#14 w/3" steel disk												
4. Underlayment:	Per Page 5												
5. Bearing Plate	6" x 6"												
6. Insulation (Optional):	Rigid Insulation Board, 4" – 6"												
Support:	Type: Steel Deck (Design of support and its attachment to support framing is outside the scope of this evaluation.) Description: <ul style="list-style-type: none">• 22 Gauge minimum• Yield Strength: 40 ksi minimum												
Slope:	Minimum slope shall be in compliance with FBC Chapter 15 Section 1507.4.2, applicable code sections and in accordance with manufacturer's recommendations.												
Performance:	Wind Uplift Resistance: <ul style="list-style-type: none">• Design Uplift Pressure: Refer to Table A (Refer to "Table A" attachment details herein)												

- Performance Standards:** The product described herein has demonstrated compliance with:
- UL580-06 – *Test for Uplift Resistance of Roof Assemblies*
 - UL 1897-12 – *Uplift test for roof covering systems*
 - TAS 125-03 – *Standard Requirements for Metal Roofing Systems*
- Standards Equivalency:** The UL 580-94, UL 1897-98, UL 1897-04 standard version used to test the product meets the prescribed standards in UL 580-06 & UL 1897-12 standard version adopted by the Florida Building Code 7th Edition (2020) for use as evaluated in this report.
- Code Compliance:** The product(s) described herein have demonstrated compliance with the performance standards listed above as referenced in the current Florida Building Code.
- Evaluation Report Scope:** This product evaluation is limited to compliance with the structural requirements of the Florida Building Code, as related to the scope section to Florida Product Approval Rule 61G20-3.001.
- Limitations and Conditions of Use:**
- Scope of “Limitations and Conditions of Use” for this evaluation:
This evaluation report for “Optional Statewide Approval” contains technical documentation, specifications and installation method(s) which include “Limitations and Conditions of Use” throughout the report in accordance with Rule 61G20-3.005. Per Rule 61G20-3.004, the Florida Building Commission is the authority to approve products under “Optional Statewide Approval”.
 - Option for application outside “Limitations and Conditions of Use”
Rule 61G20-3.005(1)(e) allows engineering analysis for “project specific approval by the local authorities having jurisdiction in accordance with the alternate methods and materials authorized in the Code”. Any modification of the product as evaluated in this report and approved by the Florida Building Commission is outside the scope of this evaluation and will be the responsibility of others.
 - This report is a building code product evaluation per FLPE rule (FAC) 61G15-36 to comply with Florida product approval rule (FAC) 61G20-3. This evaluation report is part of the Florida Building Commission approval for the listed code related criteria. This report by James Buckner, P.E. and CBLUEK Engineering is not a design certification of code compliance construction submittal documentation, per FBC section 107, for any individual structure, site specific or permit design.
 - All metal components and fasteners shall be corrosion resistant in accordance with applicable sections of FBC.
 - Design of support system is outside the scope of this report. Support shall be designed by others and shall comply with the FBC Chapters 22 for steel and Chapter 16 for structural loading.
 - Fire Classification is outside the scope of Rule 61G20-3, and is therefore not included in this evaluation.
- Quality Assurance:** The manufacturer has demonstrated compliance of roof panel products in accordance with the Florida Building Code and Rule 61G20-3.0005 (3) for manufacturing under a quality assurance program audited by an approved quality assurance entity through UL, LLC (FBC Organization #: QUA 9625).

**Components/Materials
(by Manufacturer):**

Roof Panel:
Material: Berridge "Tee-Lock"
Aluminum
Thickness: 0.032" (min.)
Panel Width: 18" (max.) Coverage
Rib Height: 2-3/8"
Alloy Type: 3105-H14 per ASTM B209
Corrosion Resistance: In compliance with FBC Section 1507.4.3

Roof Panel Clip:
Type: Berridge Tee-Lock clip
One-Piece, Fixed panel clip
Overall Dimensions: 2.69"(tall) x 2.45"(wide) x 6" (long)
Material: 304 Stainless Steel
Thickness: 16 Gauge
Yield Strength: 50 ksi min.
Corrosion Resistance: Per FBC Section 1506.7

Fastener:
Type: Hex Washer Head Self-Drilling Screw
Size: #14 - 13 x 9" with 3" steel disk
Corrosion Resistance: Per FBC Section 1506.6 and 1507.4.4
Standard: Per FBC Section 1506.6

Bearing Plate:
Material: Galvanized Steel
Size: 6" x 6"
Thickness: 24 gauge
Yield Strength: 40 ksi min.

Underlayment:

Material and application shall be in compliance with FBC Section 1507.1.1 and in accordance with applicable code sections and manufacturer's recommendations.

**Components& Materials:
(by Others) Insulation (Optional):**

Type: Rigid Insulation Board
Thickness: 4" - 6" (max.)
Properties:
Density: 2.25 pcf (lbs/ft³) min.
Or Compressive Strength: 20 psi min.

Insulation Notes:

- Rigid Insulation shall meet minimum density OR compressive strength.
- Insulation shall comply with FBC Section 1508. When insulation is incorporated, fastener length shall conform to penetrate thru bottom of support a minimum of 3/4".

Installation Method:

(Refer to **"TABLE A"** below and drawings at the end of this report.)

- Clip Spacing
(along the length of the panel): **Refer to "TABLE A" Below**
- Rib Interlock: Mechanically seamed
- Minimum fastener penetration thru bottom of support, 3/4".
- For panel construction at the end of panels, refer to manufacturer's instructions and any site specific design.

TABLE "A" ALLOWABLE LOADS "Tee-Lock" (0.032" Alum.) 18" Wide Roof Panel attached to Steel Deck							
	Clip Spacing	Insulation	Panel Clip Type	Fastener	# Fasteners per Clip	Panel Seam	Design Pressure (ASD)
METHOD 1	36"	4"-6"	Fixed, Tee-Lock	#14 w/3" disk	2	Mech Seam	- 77.5 PSF
METHOD 1	12"	4"-6"	Fixed, Tee-Lock	#14 w/3" disk	2	Mech Seam	- 188.5 PSF
<ul style="list-style-type: none"> • Allowable design pressure(s) for allowable stress design (ASD). 							

Install the "Tee-Lock" roof panel assembly in compliance with the installation method listed in this report and applicable code sections of FBC 7th Edition (2020). The installation method described herein is in accordance with the scope of this evaluation report. Refer to manufacturer's installation instructions as a supplemental guide for attachment.

Referenced Data:

1. TAS 125-03 Uplift Test (Per UL580-06 and UL 1897-04)
 By Force Engineering & Testing Inc., Inc. (TST ID: 5328)
 - Report # 49-0086T-16A,B, Report Date: 5/11/16
2. Quality Assurance
 UL, LLC (FBC Organization #: QUA 9625)
3. Certification of Independence
 By James L. Buckner, P.E. @ CBUCK Engineering
 (FBC Organization # ANE 1916)

Installation Method
Berridge Manufacturing Company
"Tee-Lock" (0.032" Aluminum) Roof Panel attached to Steel Deck

Drawings

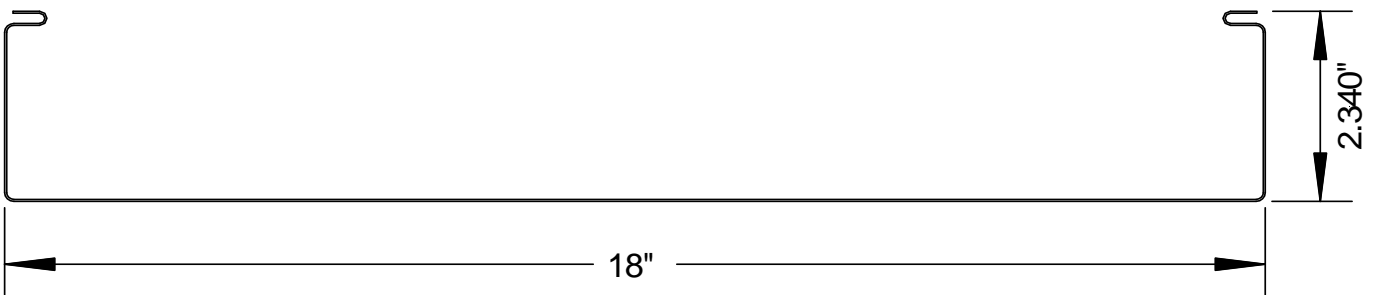

**Berridge Tee-Lock
Typical Panel Profile**

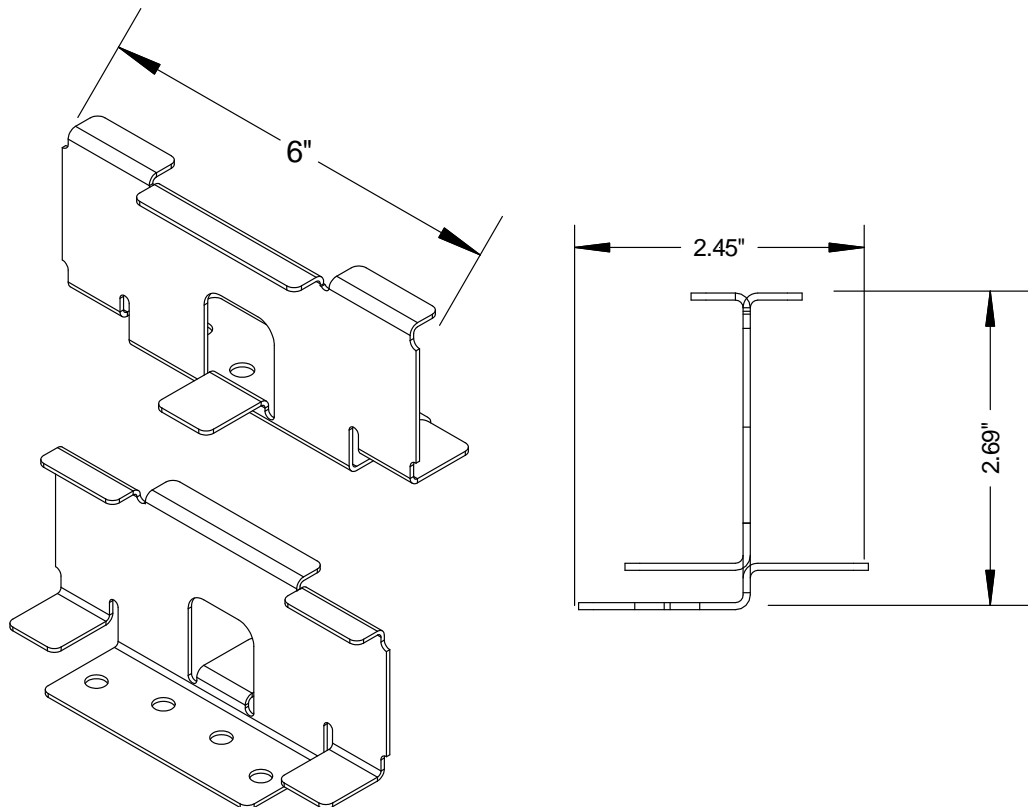

**Berridge One-Piece Fixed Tee-Lock Panel Clip
Typical Clip Profile**

Installation Method Berridge Manufacturing Company "Tee-Lock" (0.032" Aluminum) Roof Panel attached to Steel Deck

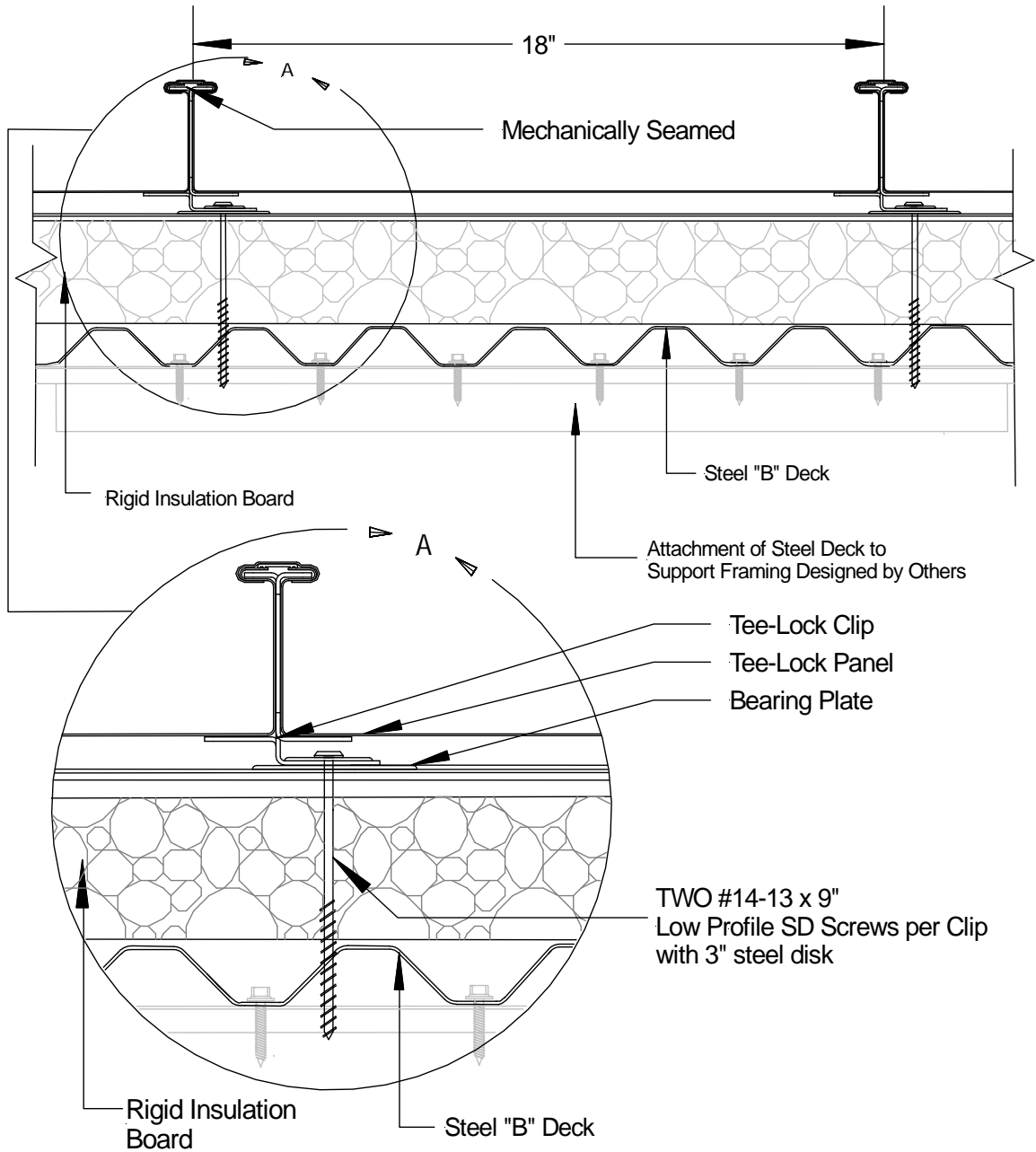

Typical Assembly Profile View
(Typical Fastening Pattern Across Width)

Installation Method Berridge Manufacturing Company "Tee-Lock" (0.032" Aluminum) Roof Panel attached to Steel Deck

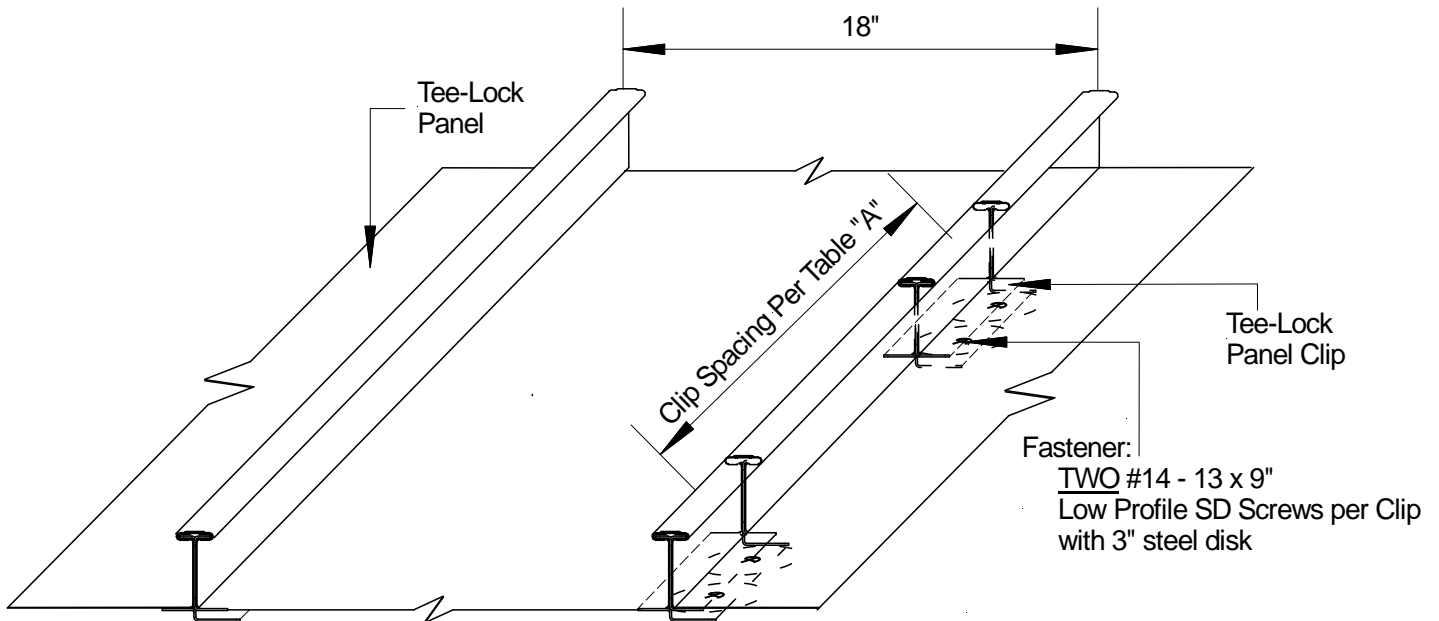

**Typical Roof Assembly
Isometric View**

(Optional) Rigid Insulation Board per Page 4 of this report.

TABLE "A"							
ALLOWABLE LOADS							
"Tee-Lock" (0.032" Alum.) 18" Wide Roof Panel attached to Steel Deck							
	Clip Spacing	Insulation	Panel Clip Type	Fastener	# Fasteners per Clip	Panel Seam	Design Pressure (ASD)
METHOD 1	36"	4"-6"	Fixed, Tee-Lock	#14 w/3" disk	2	Mech Seam	- 77.5 PSF
METHOD 1	12"	4"-6"	Fixed, Tee-Lock	#14 w/3" disk	2	Mech Seam	- 188.5 PSF