

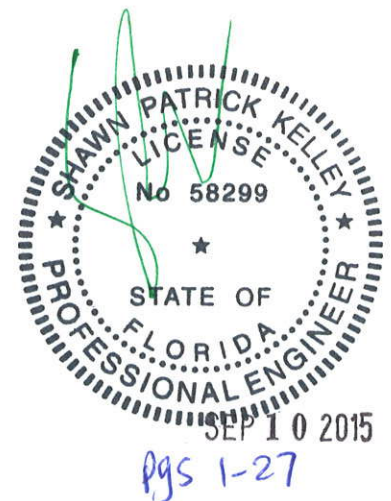

# *Counter Door Installation Instructions*



## Section 1 – Table of Contents





|  |    |
|--|----|
| <b>Section 2 – Safety Check List</b>           | 2  |
| <b>Section 3 – Freight Receiving</b>           | 3  |
| <b>Section 4 – Pre-installation</b>            | 4  |
| <b>Section 5 – Guides</b>                      | 5  |
| Face-Of-Wall                                   | 5  |
| Between Jambs                                  | 7  |
| <b>Section 6 – Barrel and Brackets</b>         | 10 |
| Preparation                                    | 10 |
| Ring Attachment                                | 11 |
| Bracket Preparation                            | 12 |
| Hoisting and Installing Barrel Assembly        | 12 |
| <b>Section 7 – Motor Operator Installation</b> | 15 |
| <b>Section 8 – Curtain Installation</b>        | 16 |
| Applying Spring Turns                          | 17 |
| <b>Section 9 – Hood, Fascia, and Covers</b>    | 19 |
| Hood Support Installation                      | 19 |
| Lintel Brush                                   | 19 |
| Hood and Fascia                                | 20 |
| Covers   | 21 |
| <b>Section 10 – Torque Specifications</b>      | 22 |
| <b>Section 11 – Maintenance Schedule</b>       | 23 |
| <b>Appendix A – Tube Motors</b>                | 26 |

## Section 2 – Safety Check List

Rolling doors are large, movable objects. They move with the help of electric motors or manual operators (chain, crank, push up, etc), and most have springs under high tension. These items and their components can cause injury. In order to avoid injury to yourself and others, please follow the instructions in this manual.

- Review the potential hazards and preventative measures listed below:

**Table 2.1 - Potential Hazards and Preventative Measures**

| Potential Hazard  |  | Preventative Measure   |
|---|--|--|
|    | <b>⚠ DANGER</b><br>Pinned or crushed by closing door.                          | <ul style="list-style-type: none"> <li>• Keep yourself and others clear of opening while door is in motion.</li> <li>• Do not allow children to play near or operate door.</li> <li>• Do not operate if door becomes jammed or broken.</li> </ul>  |
|    | <b>⚠ WARNING</b><br>Struck by adjusting wheel bar while applying spring turns. | <ul style="list-style-type: none"> <li>• Be sure bar is adequate in strength and long enough to allow installer to apply the necessary torque.</li> <li>• Make sure bar is fully seated into the adjusting wheel slot before applying pressure.</li> <li>• Use two bars while applying turns to the adjusting wheel.</li> </ul>  |
|    | <b>⚠ WARNING</b><br>Electrical shock.  | <ul style="list-style-type: none"> <li>• Make sure electrical operator is properly grounded.</li> <li>• Turn off source power completely prior to servicing the motor.</li> <li>• Make sure wires are clear of any moving or potentially moving parts.</li> <li>• Avoid pinching wires when installing the motor cover.</li> </ul>   |
|  | <b>⚠ WARNING</b><br>Pinched by moving components.                              | <ul style="list-style-type: none"> <li>• Make sure the motor is turned off and unplugged before working with moving parts such as roller chain and sprockets, drop-out mechanisms, adjusting wheels, etc.</li> <li>• Locate the possible pinch-points of the unit (Drive chain, coil area, bottom bar, etc.) Do not operate the door while someone is near these areas.</li> </ul> |

- Check the following during installation and before leaving the job site:
  - a. If the unit has tension springs, be sure the proper amount of tension is applied to the torsion springs, in order to properly counterbalance the weight of the curtain.
  - b. Securely fasten the tension adjusting wheel in place with the appropriate hardware provided.
  - c. Check that the keys and/or cotter pins have been set in place and fit properly at all sprockets or gears.
  - d. Check that the setscrews in each sprocket or gear (one over the key and one offset from the key) have been tightened properly.
  - e. Check all fasteners holding the unit to the building structures.
  - f. Check all fasteners used to assemble the components of the unit together.
  - g. Instruct owner or representative in the proper method of operating the door.

### Section 3 - Freight Receiving

- Upon delivery, check condition of components for damage.
- If damage occurred in transit, the installation should not proceed without authorization.

#### **NOTICE**

If the installation proceeds, neither the carrier nor the manufacturer will assume responsibility for replacing the damaged material.

- **If the installation is stopped due to damage, do the following:**
  1. Take pictures of the damage.
  2. Do not move material from point of delivery to other premises once the damaged components are discovered.
  3. Do not unpack, if the damage is visible prior to removing packaging, until an inspection is made.
  4. If the damage is found while removing contents from packaging, the packaging material must be saved until inspection is made.
  5. Container and packaging should be retained by consignee until inspection is made.
  6. Have components inspected by carrier's representative within 15 days from date of delivery.
  7. Consignee must obtain a copy of the Inspection Report.
- **Returning damaged components:**
  1. Obtain permission from carrier to return.
  2. Route the return shipment via the identical carrier(s) involved in the original shipment.
  3. Notify the manufacturer when shipment is returned to manufacture plant.
- **Verify that all components have arrived. Look for the following:**
  1. Job construction drawings featuring different views (elevation, section, plan, etc.)
  2. (2) Guide assemblies; check for guide weathering if included in order
  3. Barrel assembly
  4. Curtain assembly with bottom bar attached
  5. (2) Bracket assemblies
  6. Operator; if not attached to bracket
  7. Operator cover; may not be included in order
  8. Adjusting wheel; if the barrel assembly contains springs
  9. Inertia brake; typically on units with springless barrel assemblies
  10. Hood and hood supports; may not be included in order
  11. Hardware
  12. Misc. items (Reelite, lintel seal, hood baffle, etc.)
  13. Verify material/finish/color of components matches what is listed on the job construction drawings and/or what was ordered.
- **If the delivery is incomplete:**
  1. Make note on delivery receipt.
  2. Note should be verified by driver's signature.
  3. Notify carrier and manufacturer.

## Section 4 - Pre-installation

- Read entire instruction manual thoroughly. The manufacturer will not be held responsible for any charges incurred due to improperly installed components.
  - a. Only trained door systems technicians should perform installation, maintenance, etc.
  - b. Each unit comes with an individual item number. If the job contains multiple units, be sure to locate all the components for each item and separate each.

### **⚠ WARNING**

**Do not** interchange parts from one door to another.

- c. Find the job construction drawings for the unit being installed and check the dimensions of the opening against those on the drawings. See **Figure 4.1** below.
- d. If the opening dimensions differ from those on the drawings, **do not proceed**, check with distributor/manufacturer to be sure the correct door is being installed.
- e. Check the jambs of the opening for plumb. Check the head/lintel and floor for level. If the unit is to be free standing, for example mounted to tubes, check the floor and ceiling for level and for adequate mounting areas at the top and bottom.

**Note:** The floor may not be level if a pitched bottom bar is specified.

- **Work Area:**
  - a. The key to a smooth installation is a clean and well-prepared work environment. Once the components have been inspected and the job construction drawings have been reviewed; lay out the components in the order of installation.
  - b. The opening for the door should be cleaned and inspected for rough surfaces and construction debris.
  - c. Lastly the mounting hardware supplied with the door should correspond with the surface and construction features of the opening.
  - d. The basic assembly sequence is as follows: guides, barrel w/ rings or tapped holes, brackets, motor operator (if applicable), curtain, bellmouth, stoppers, weather stripping, hood, and operator/adjustor/idler covers.

**Figure 4.1 - Opening Dimensions and Designations**

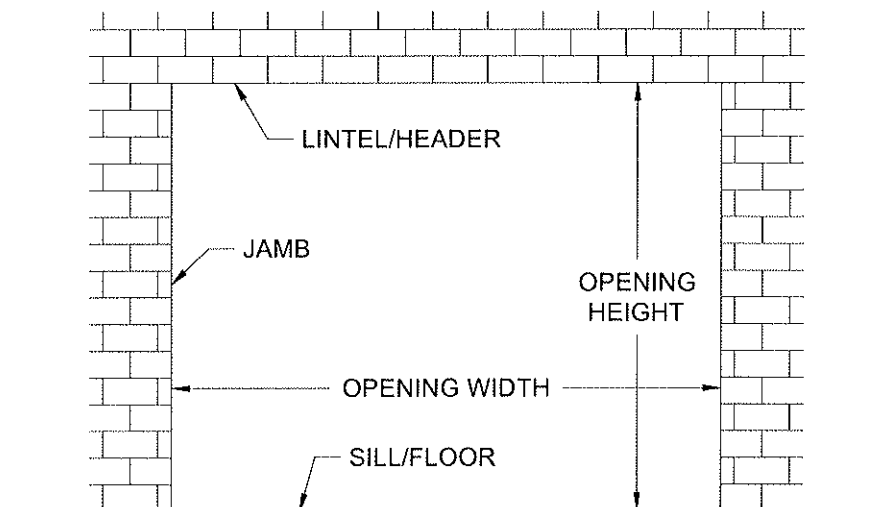

## Section 5 - Guides

### ▪ Face of Wall Units (Figures 5.1 - 5.2):

**Note:** Determine the specified guide configuration for the door from the job construction drawings. Compare to the diagrams below.<sup>1</sup>

**Figure 5.1 –Face of Wall Guide (extruded aluminum)**

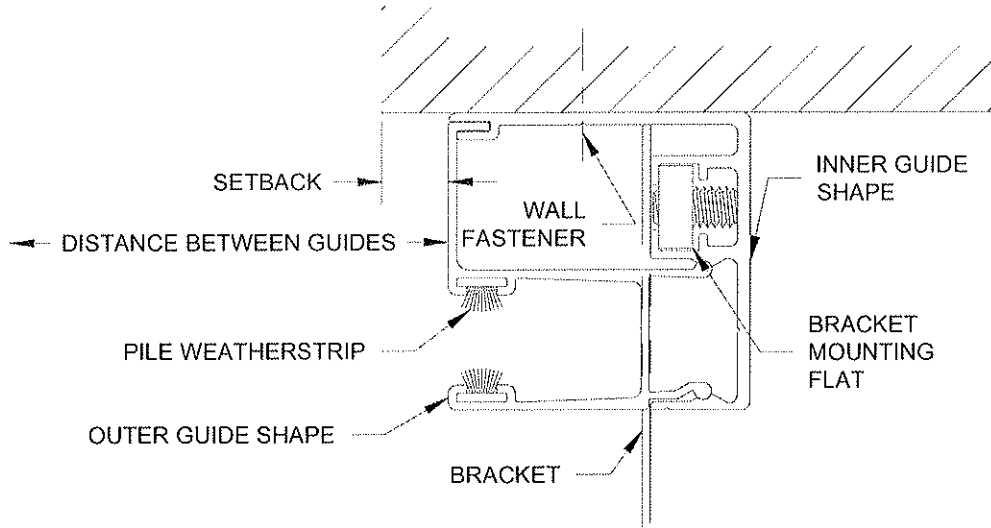

**Figure 5.2 – Face of Wall Guide (steel)**

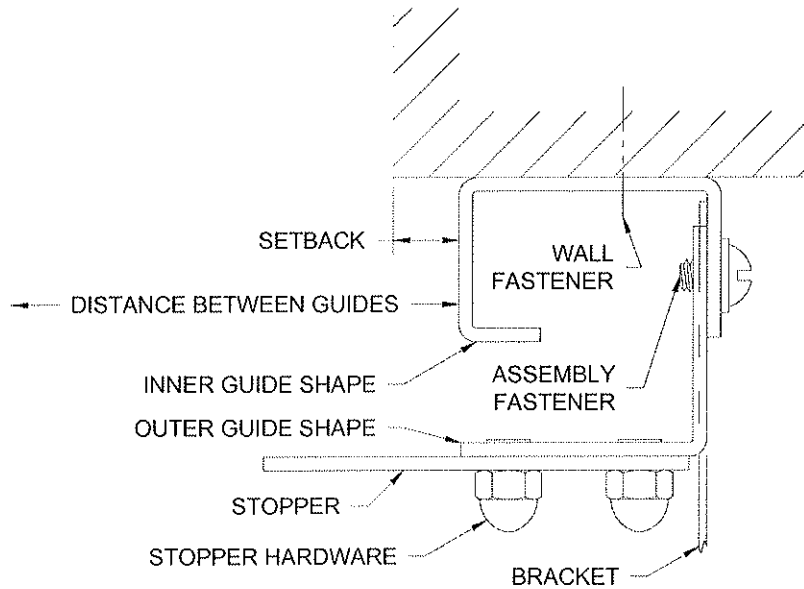

<sup>1</sup> The guide assembly may differ from the right to left hand side of the unit. In these cases, follow the directions for each particular guide assembly, as well as the job construction drawings provided with the unit.

## Section 5 - Guides

1. Disassemble the inner and outer guide shapes. This is necessary to mount the inner shape to the wall.
2. If the guide is setback from the jamb:
  - a. Determine the required "Setback" dimension for each side of the unit from the job information. See **Figures 5.1-5.2** for visual reference of the "Setback" dimension.
  - b. Measure from the jamb to the inner guide shape.
  - c. Place a mark on the floor at measured location.
3. Measure the "Distance Between Guides" dimension. This is the distance between the inner guide shapes. See **Figures 5.1-5.2**. For guides with no setback, simply measure from jamb wall-to-jamb wall.
4. Ensure this measurement matches the "Distance Between Guides" dimension specified on the job construction drawings.
5. If the measurement does not equal the dimension on the job construction drawings, **STOP**. Check the guide dimensions against those on the job construction drawings to be sure the correct guides are being installed. If so, repeat previous step and re-check.

**Note:** *If the measurement is still not equal, contact the distributor.*

6. Place the inner guide shape(s) against the wall and plumb. Mark the location of the wall fastener holes.

### **NOTICE**

If the guides are extruded aluminum, install the bracket mounting flat at this time. This is done by sliding the flat into the top of the inner guide shape (see **Figure 5.1**) until it they are flush with each other at the top. Anchor the flat in place using the 5/16-18 socket head set screw. See **Figure 6.5** for orientation of flat.

7. Check the job construction drawings for the specified wall fasteners. Drill mounting holes for the wall fasteners. Fasten to wall using the provided fasteners.
8. Plumb the guide and tighten the wall fasteners to the recommended installation torque. See **Table 10.1**.
9. For steel guides: Do **not** attach the outer guide shape to the inner guide shape until the curtain is installed. The installation of the curtain will be much easier without the outer guide installed.
10. For extruded aluminum guides: the outer guide shape can be "popped" into the inner guide shape now, taking care to keep the two flush at the bottom.
11. If a brush seal is required, attach it to the inner guide shape, **for steel guides only**.
12. For steel guides: Once the curtain is installed the outer guide shape can be attached to the inner with the hardware provided, keeping the outer guide shape flush with the bottom of the inner guide shape.

## Section 5 - Guides

### Between Jambs Units (Figures 5.3-5.5):

**Note:** Determine the specified guide configuration for the door from the job construction drawings and compare to the diagrams below.<sup>2</sup>

Figure 5.3 – Between Jambs Guide (extruded aluminum)

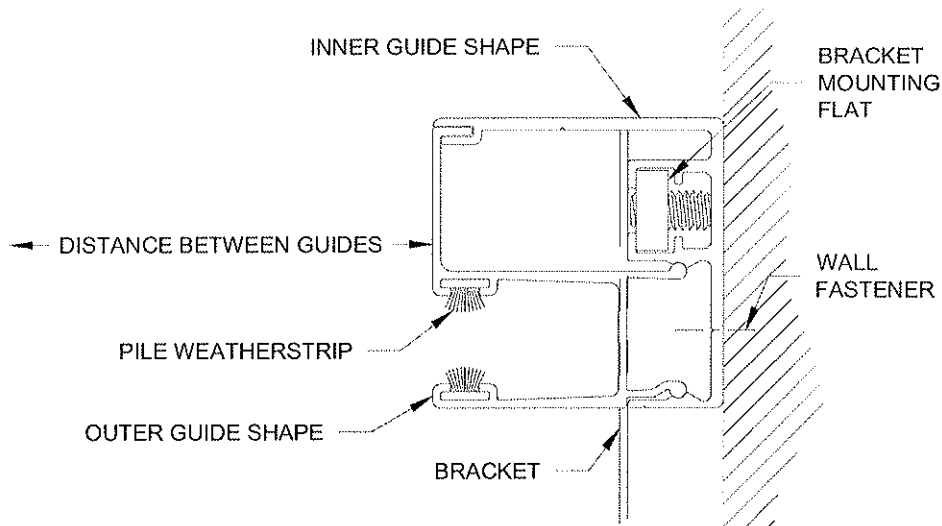
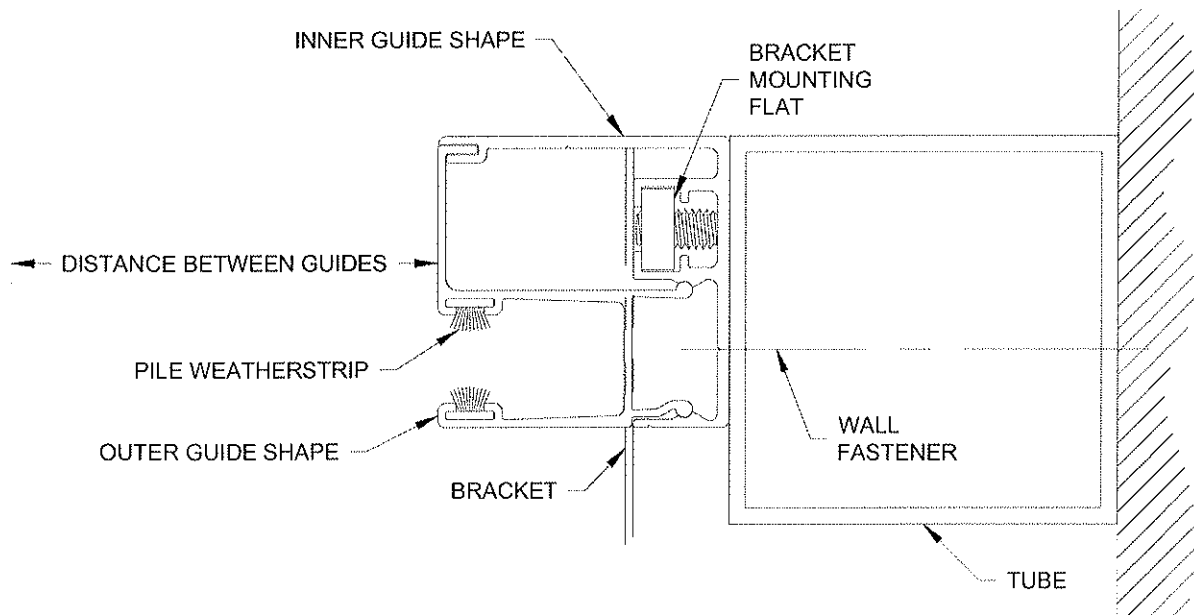

Figure 5.4 – Between Jambs Guide with Aluminum Tube (extruded aluminum)



<sup>2</sup> The guide assembly may differ from the right to left hand side of the unit. In these cases, follow the directions for each particular guide assembly, as well as the job construction drawings provided with the unit.



## Section 5 - Guides

Figure 5.5 – Between Jambs Guide (steel)<sup>3</sup>

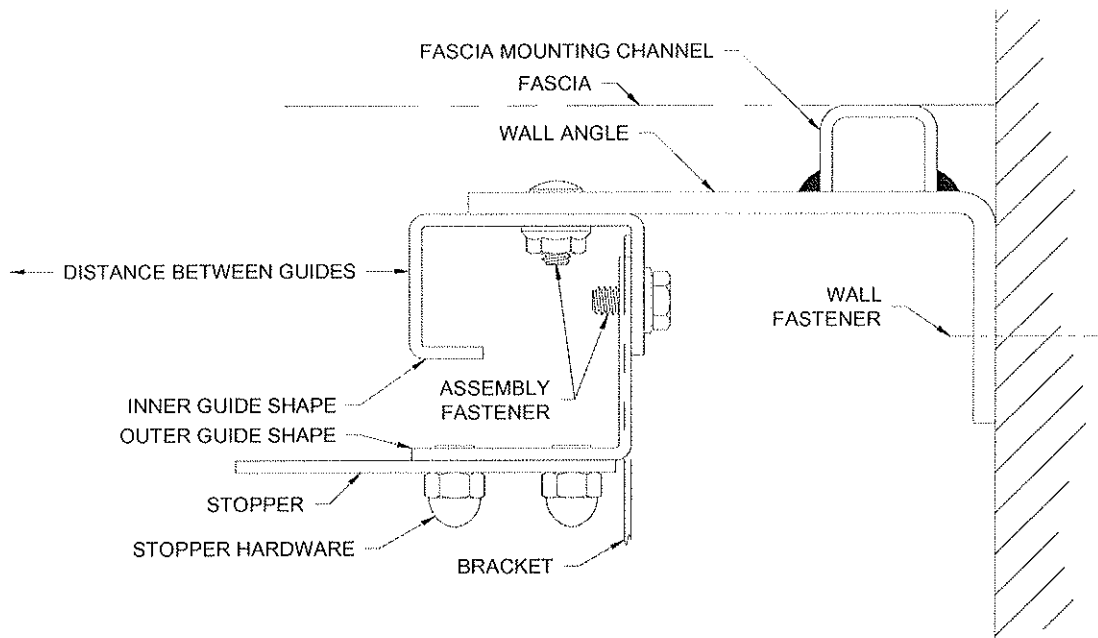

1. Disassemble the inner and outer guide shapes, as well as the wall angle or tube (if they are part of the assembly). Doing so will make it easier to maneuver the guide parts when locating the guide on the jamb.
2. Verify that the opening width matches the job construction drawings by measuring the distance between jambs. If this distance is not equal to the job construction drawing dimension, **do not proceed!!** Be sure the correct unit is being installed. Contact the project manager.
3. Use the job construction drawings to locate the guides on the jamb. Be sure to allow room for the fascia mounting channel that is welded to the wall angle on between jambs **steel** guides. See **Figure 5.5**.
4. If a header/lintel exists, see the elevation view of the job construction drawings to determine if the door is to be placed against the header. If so, project a plumb line from the header to the floor. Mark the floor at this location.
5. If a header / lintel does **not** exist, or if the door is not going to be placed against the header / lintel, contact the project manager to determine where the door will be located. Mark the floor at this location and scribe a plumb line up the jambs.
6. Stand the mounting member up to its corresponding jamb.

**Note:** The **mounting member** is the inner guide shape-for aluminum guides, tube-for aluminum guides with tube, or wall angle-for steel guides.

Use the markings made in the previous steps to locate and plumb the mounting member. Mark the location of the wall fastener mounting holes.

<sup>3</sup> The wall angle shown is for the operator jamb. The wall angle is slightly smaller for push up units and on the adjuster side.

## Section 5 - Guides

### **NOTICE**

If the guides are extruded aluminum, install the bracket mounting flat at this time. This is done by sliding the flat into the top of the inner guide shape (see **Figures 5.3 or 5.4**) until they are flush with each other at the top. Anchor the flat in place using the 5/16-18 socket head set screw. See **Figure 6.5** for orientation of flat.

7. Check the job construction drawings for the specified wall fasteners. Drill mounting holes for the wall fasteners and fasten the mounting member with the provided hardware.
8. Plumb the mounting member and tighten the fasteners to the recommended torque in **Table 10.1**.
9. Attach the inner guide shape to the mounting member with the provided hardware, making sure that it is flush with the bottom of the mounting member. Preload the assembly fasteners to the recommended torque in **Table 10.1**.

**Note:** If the guide consists of only an inner and outer guide shape, the inner guide shape should be attached to the wall at this point, as it is considered the mounting member.

10. Measure the "*Distance Between Guides*" dimension and compare it to the dimension specified on the job construction drawings. Refer to **Figures 5.3-5.5** for a visual representation of the dimension.

### **NOTICE**

If the "*Distance Between Guides*" dimension does not equal the dimension on the job construction drawings, **STOP**. Check the guide dimensions against those on the job construction drawings to be sure the correct guide is being installed. If so, repeat the previous steps and check the "*Distance Between Guides*" dimension again.

13. For steel guides: Do **not** attach the outer guide shape to the inner guide shape until the curtain is installed. The installation of the curtain will be much easier without the outer guide installed.
14. For extruded aluminum guides: the outer guide shape can be "popped" into the inner guide shape now, taking care to keep the two flush at the bottom.
15. If a brush seal is required, attach it to the inner guide shape, **for steel guides only**.
16. For steel guides: Once the curtain is installed the outer guide shape can be attached to the inner with the hardware provided, keeping the outer guide shape flush with the bottom of the inner guide shape.

- **Mixed Guides (One Face of Wall and One Between Jambs):**

1. Refer to the job construction drawings for specific mounting information.
2. Follow the steps in the preceding sections for each of the respective guide configurations.
3. Ensure that the guide centers (centerline of the guide openings where the curtain rides) are aligned before proceeding.

## Section 6 – Barrel and Brackets

### ▪ Preparation of the Barrel and Brackets

**Note:** Check to see if a hood support will be required. If so, refer to the “**Hood Support Installation**” section before proceeding to the barrel and brackets.

1. Refer to the job construction drawings to determine the “coil side” of the opening, or the side of the opening on which the coil is to be installed. Then determine which jamb wall is your “operator side”, or side on which the operator is to be installed. The following instructions refer to these directional cues.

**Note:** Units without operators (such as push-up units) are still considered to have an “operator” side. The shaft and job drawings will be marked with “operator” side regardless of the operation of the door so that it can be used as a directional cue.

2. Unpack the barrel assembly. Note the markings on the barrel, see **Figure 6.1** below.

**Figure 6.1 – Barrel Markings (Left Hand Adjust Shown)**

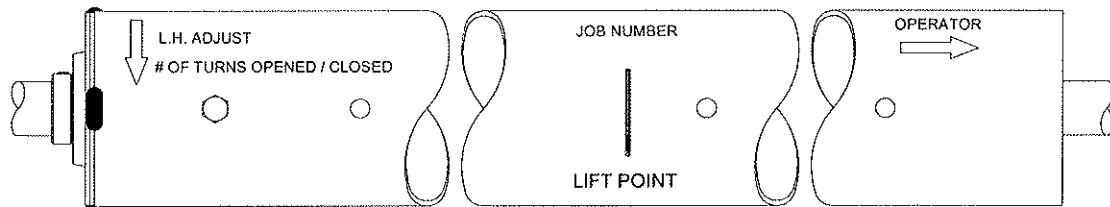

3. Position the barrel assembly on the coil side of the opening, with the end marked “operator” towards the “operator side” of the opening. In order to alleviate the ring and bracket installation, place the barrel assembly on blocks or spacers such that it is elevated off the ground.

**Note:** Choose sufficiently sized blocks. The barrel assembly should be elevated off the ground enough that the brackets can be installed without contacting the floor.

4. Check to make sure the required number of turns is noted on the barrel, as shown in **Figure 6.1**. Consult the distributor or the manufacturer if you cannot locate this information. Check that these numbers match the information provided on the job information. Take note of these numbers, as access to this information may be obstructed once the curtain is installed.
5. Typically the adjusting wheel is not shipped attached to the barrel. However, if the adjusting wheel is attached to the barrel, remove by loosening the bolt or set screws that secure the adjusting wheel to the barrel and sliding the wheel off the inner shaft. See **Figure 6.2**.

**Figure 6.2 – Removal of Adjustor From Barrel Assembly**

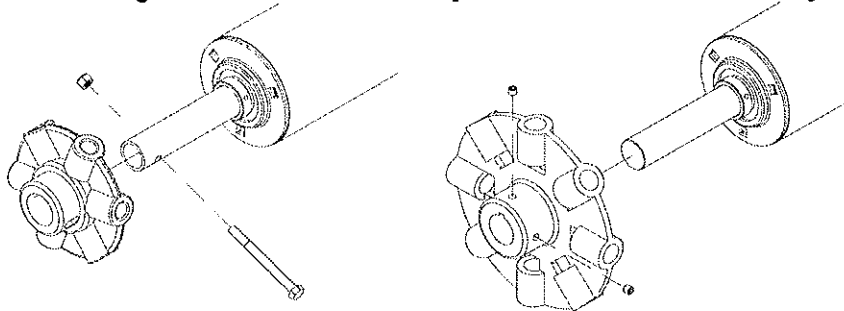

6. Refer to the job information provided with the door to determine the correct ring type and quantity.
7. Locate the rings in the hardware bag/box provided. Check that you were supplied the correct type and quantity. (Use **Figure 6.3** as a visual aid.)
8. Use the information in **Figure 6.3** to install the rings.

## Section 6 – Barrel and Brackets

**Note:** It is critical that the rings are installed correctly in relation to the coiling direction, or the direction of wrap as the door travels upward. The rings act as graduated spacers, meaning they increase in diameter such that the curtain wraps in a consistent and smooth manner. Use the arrows on the figures below to determine the correct orientation of the rings in relation to the coiling direction.

Figure 6.3 – Ring Installation

### SA0114 Extruded Rings:

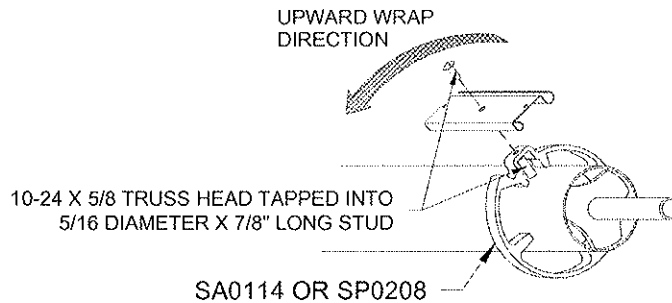

- Slide the ring over the barrel, noting direction of wrap, and rotate the ring fits over the 5/16" diameter x 7/8" long stud that is welded to the barrel.
- At this time there is no additional assembly required until the curtain is to be fastened to the barrel. In which case, the fastening section slat is fastened to the barrel using the #10-24 screws provided.

### SP0251 Cast Rings:

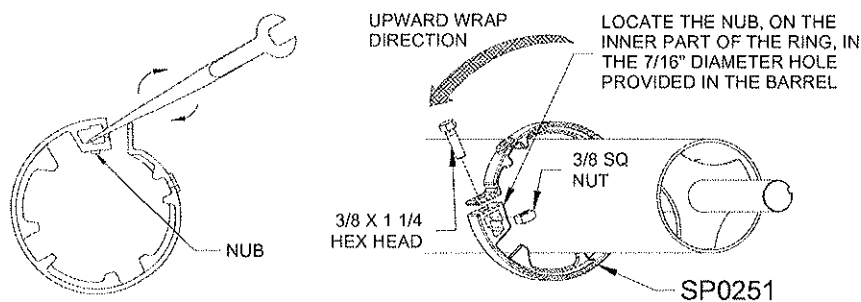

- Use a small pry bar or large standard screwdriver to spread the gap in the ring by prying between bolt flange and the nut cradle of the casting.
- Slide the ring over the barrel, noting direction of wrap, and rotate the ring so the locating nub in the casting aligns with the locating hole in the barrel.
- Insert the 3/8 square nut into the nut cradle of the casting and the 3/8" x 1-1/4" hex bolt through the bolt flange in the casting and tighten to minimum 20 ft-lbs of torque.
- Be sure ring sits straight on barrel.

### SP0003 Stamped Rings:

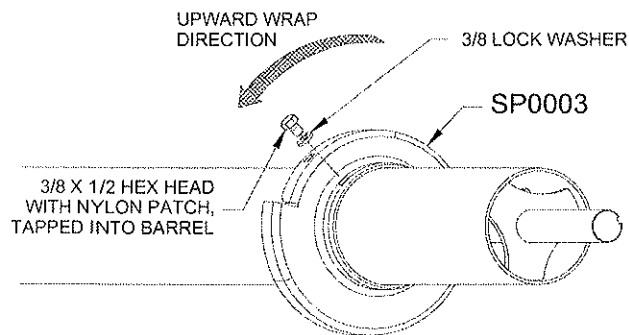

- Slip the rings over the barrel, noting direction of wrap, and place over tapped hole in barrel. Insert the 3/8" x 1/2" hex bolt (with nylon patch on threads) through the ring into the tapped hole in barrel.
- Be sure rings sit straight on barrel and tighten the fasteners to minimum 20 ft lbs of torque.

## Section 6 – Barrel and Brackets

### SP0322 Spacer Rings:

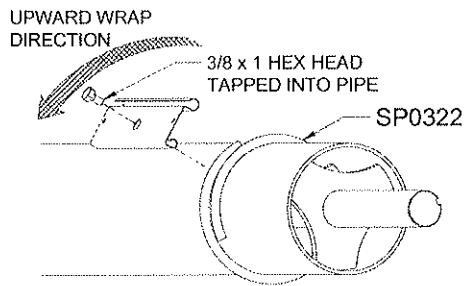

- Slip the rings over the barrel and place over tapped hole in barrel. Insert the 3/8" x 1" hex bolt through the ring into the tapped hole in barrel.
- Be sure rings sit straight on barrel and tighten the fasteners to minimum 20 ft lbs of torque.

9. Locate the brackets. Determine the "operator" and "adjustor" brackets by referring to **Figure 6.4**. The "operator" bracket may vary significantly based on the operation of the door. The "adjustor" bracket will contain a label with spring adjustment instructions.
10. Remove the adjusting wheel if you haven't previously done so, and slide the adjustor bracket over the inner shaft of the barrel assembly. The hood clip angles should be facing inwards. Install the adjusting wheel (see **Figure 6.2**).
11. Align the bearing and sprocket(s) and slide the assembly over the gear end until the inside face of the bracket is approximately 3 inches from the edge of the outer shaft. It is recommended that you install the keys, located in the bag of hardware you removed with the temporary plug, into each sprocket at this stage. Do not tighten the set screws at this point.

**Note:** Do not install the operator until the barrel and bracket assembly is hoisted into position and securely fastened to the guides. Installing the operator prior to this stage will cause the assembly to be lopsided and cumbersome, making it difficult and potentially dangerous to hoist into position.

**Figure 6.4 – Brackets and Barrel Prior to Installation**

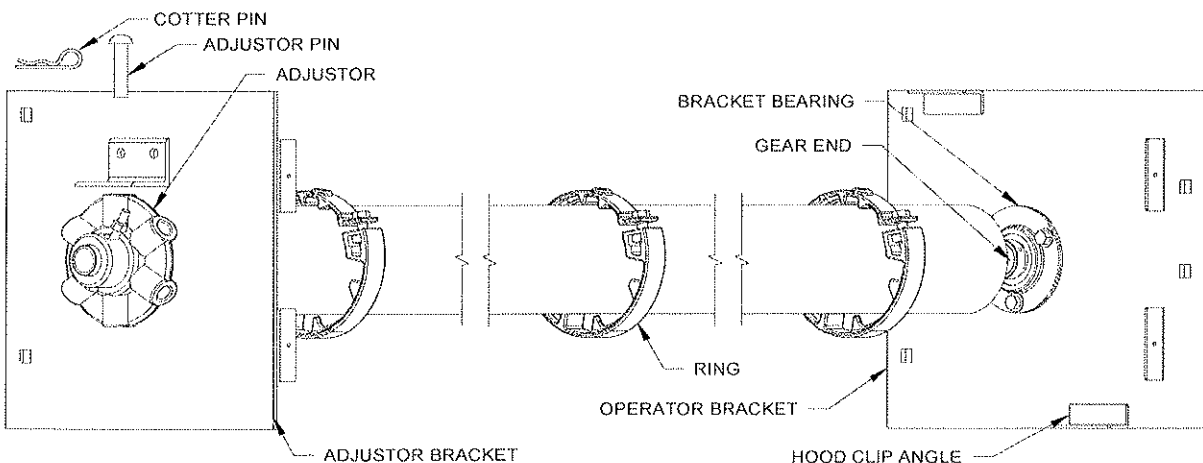

#### ▪ Hoisting and Installing Barrel Assembly

1. The following methods can be used for hoisting them into place:
  - **Crane Hoisting:** Place a sling or lifting agent under the barrel assembly at the "lift point" provided on the barrel, see **Figure 6.1**.

## Section 6 – Barrel and Brackets

- **Forklift Hoisting:** Space the forks evenly under the "lift point" provided on the barrel, see **Figure 6.1**. Ensure that the barrel assembly is positioned close enough to the tips of the forks that the fastening holes in the bracket can be aligned with those of the guides without the forks contacting the wall. Secure the barrel assembly to avoid the slipping off the tip of the forks.

### **⚠WARNING**

The addition of brackets may offset the balance slightly from when the "lift point" was marked. Check to make sure the assembly is properly balanced before hoisting.

2. Before hoisting, refer to the hardware sheet and ensure that the proper type and quantity of fasteners were provided for the bracket installation.
3. Measure the distance between the brackets and compare that to the distance measured to the inner guide shapes for steel guides and to the mounting member (where the bracket mounting flat is located) for aluminum guides. See **Figures 6.5 and 6.6** below for bracket locations in relation to the guide shape.
4. Center the barrel assembly between the guides, keeping approximately 2 feet of clearance between the barrel assembly and wall/guides.
5. Raise the barrel assembly up to the approximate bracket mounting level. The brackets should be clear of the outer and inner guide angles.

**Note:** Position the brackets in the upright position, with the mounting holes facing the wall, before moving the assembly towards the wall. It may be difficult to rotate the bracket when in close to the wall.

6. Slowly maneuver the barrel assembly towards the guide, and align the mounting holes of the brackets with those of the inner guide shapes.
7. Insert the specified bolts and snug tighten, see **Figures 6.5 and 6.6**.

**Figure 6.5 – Bracket Mounting and Hardware for Aluminum Guides**

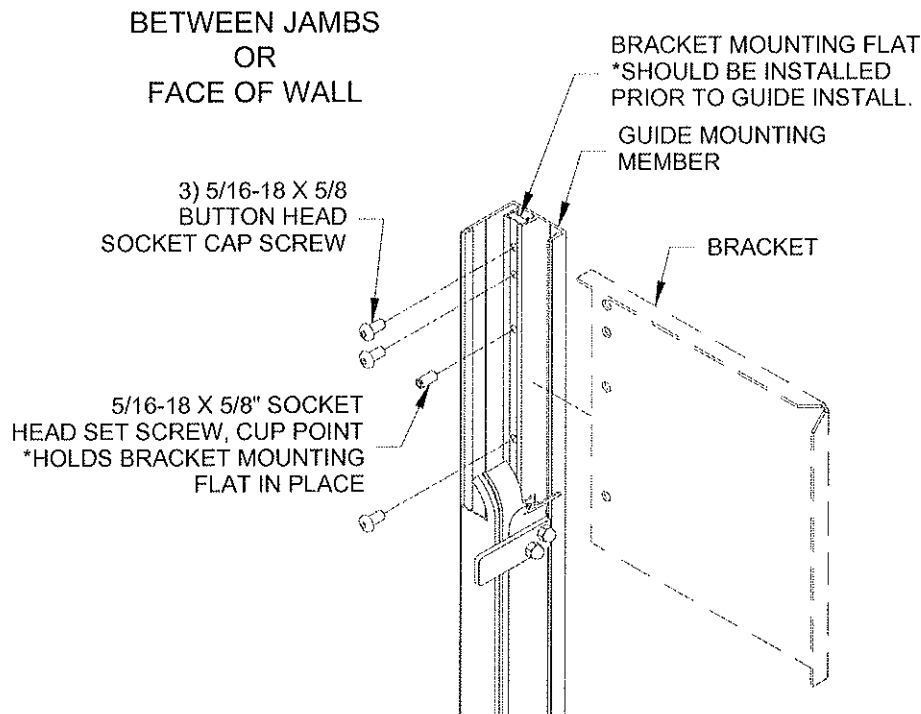

## Section 6 – Barrel and Brackets

Figure 6.6– Bracket Mounting and Hardware for Steel Guides

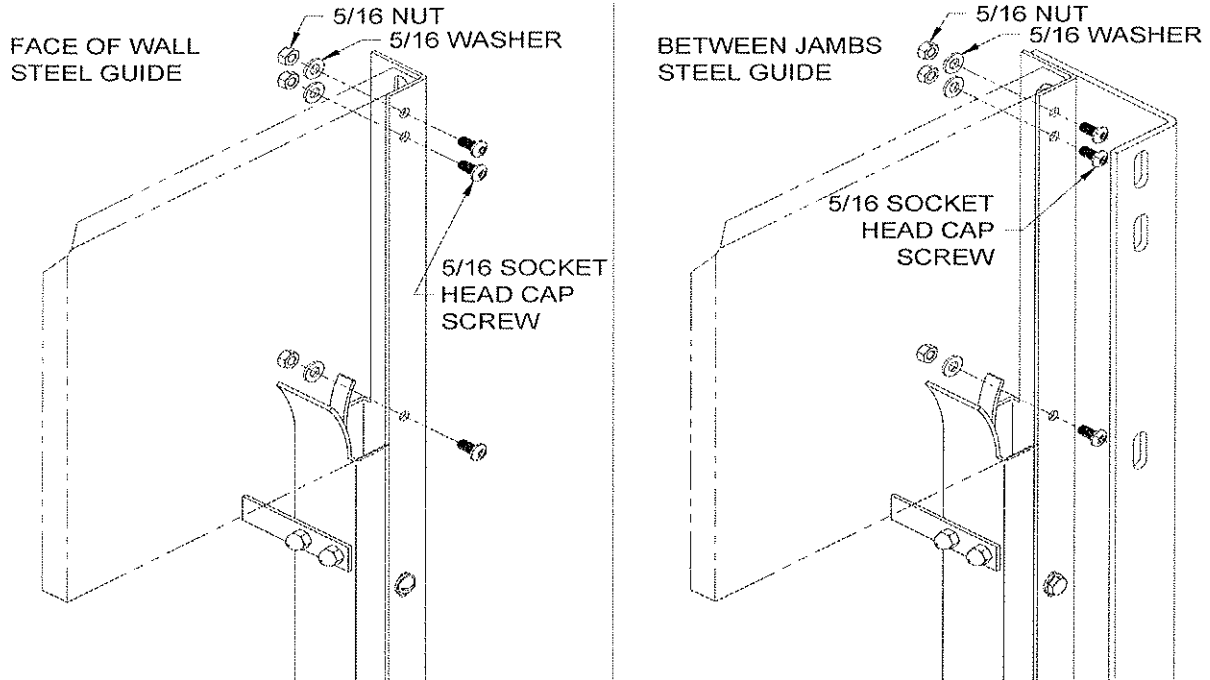

8. Check to see that the barrel is positioned properly between the brackets. That is, so that the proper amount of space is allowed between the barrel and the brackets. Typically the space is equal at both the operator and adjustor side. Adjust as necessary.
9. Place a level in the center of the barrel. If the shaft is not level:
  - Check the dimensions of the brackets from the top of the bracket to the center of the barrel.
  - Verify that the bracket mounting fasteners are the same distance from the top of the bracket.
    - a. If the dimensions **are not** correct, contact the Service Department.
    - b. If the dimensions **are** correct, the floor may be out of level, causing the bracket mounting holes in the guides to be out of alignment.
10. Fully tighten mounting bolts to the torque specifications in **Section 10**.

### **NOTICE**

Proper pretension of the bracket mounting bolts will benefit the life of the bolts and brackets.

11. If the adjusting wheel was not previously installed, install it now. Do not install the adjustor pin yet.

## Section 7 – Motor Operator Installation

### ▪ Motor Operator Installation (if required):

1. Unpack the motor operator from the shipping box and retrieve the *Operator Mounting Bracket* and bolts provided in the kit.
2. There are a few motor mounting configurations that can be formed with the supplied components. Refer to the shop drawings and components supplied with the kit in order to identify the specific style of mounting ordered for the unit. Some of the types of mounting are:
  - Vertical Bracket
  - Wall Mounting
  - Horizontal Front of Coil
3. Mount the operator mounting bracket to the operator using the supplied fasteners.
4. Mount the operator-mounting bracket to the operator bracket according to the shop drawings using the supplied fasteners.
5. Install controls and wire the operator. Refer to the wiring diagram provided with the operator for proper connections and voltages. The controls should be installed in an area from which the door/opening is clearly visible. This will allow an individual operating the unit to make a visual inspection of the opening for any obstacles or other potential hazards before setting the door into motion.

**Note:** Do not attempt to set the upper and lower limits until the curtain is installed.

### ▪ Attaching Additional Bracing (if required):

1. Attach a clip angle to the operator mounting bracket and the bracing angle to the clip angle. Snug all bolts.
2. Mount the other supplied clip angle to the bracing angle and swing the bracing angle to the wall or structural support.
3. Align the mounting face of the clip angle with the face of the wall, mark and drill a mounting hole for the size of the supplied mounting fastener, and secure the clip angle to the wall with the fastener.
4. Square the operator-mounting bracket, adjusting the bracing angle as necessary, and fully tighten all the mounting bolts.
5. Lift the motor operator into position on the mounting bracket and align it with the appropriate hole pattern. See **Figure 7.1** for operator mounting details.
6. Insert the fasteners included in the kit from the bracket side first into the mounting foot of the operator and tighten the nuts with lock washers.

**Note:** All mounting bolts are supplied with nuts and lock washers.

**Figure 7.1 – Additional Operator Bracing**

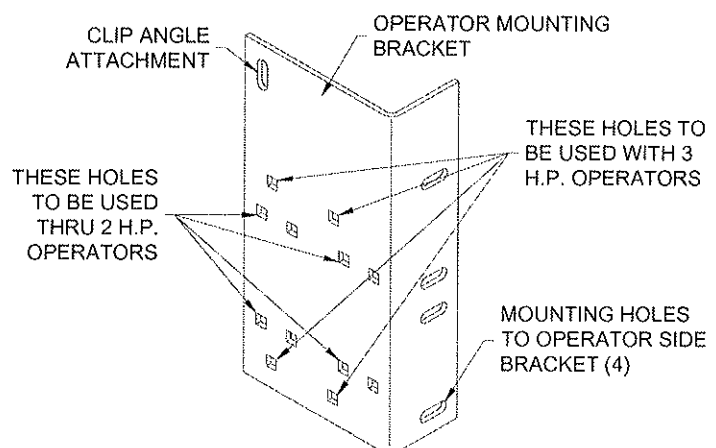



## Section 8 – Curtain Installation

### ▪ Curtain Installation

1. Remove the stoppers from the guides, or position them so they do not protrude into the opening.
2. Open the curtain packaging. Leave the plastic straps that keep the curtain from uncoiling in place. It may also be beneficial to leave some of the packaging under the curtain to protect the finish during installation.
3. The coil will be provided with the top of the curtain on the outside, thus leaving the fastening sections exposed. Position the coil on the floor between the guides so that the open end of the fastening sections is facing up and nearer the wall.

**Note:** If you have an inside adjust (see **Figure 8.1**), spring turns must be applied at this time. See **Section 8.2** for applying spring turns. Once the turns have been applied, replace the "adjustor pin" or bolt through the solid inner shaft and the lug mounted to the bracket.

**Figure 8.1 – Inside Adjustor**

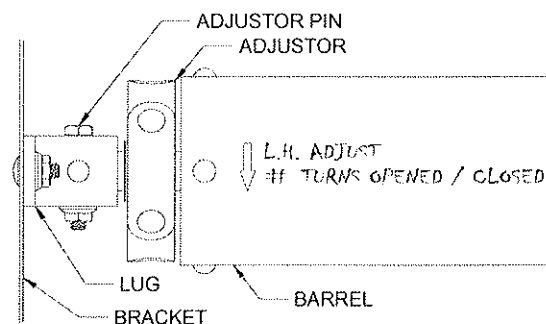

4. Locate the curtain attachment hardware provided with the unit. Refer to the job information to ensure you have the correct type and quantity.
5. Lift the coil until it is just below the shaft. Using appropriately rated straps, sling the coil from the shaft as shown in **Figure 8.4**. Remove the plastic strapping securing the coil at this point.
6. Uncoil the curtain enough for the fastening sections to reach the attachment points on the shaft. Fasten them by aligning the fastening section with the hole in the ring or shaft respectively, and fasten using the provided hardware (see **Figures 8.2 and 8.3**). If the curtain is too heavy to uncoil by hand, use the method described in the following step to get the fastening sections in position.

**Figure 8.2 – Fastening Section Attachment with Bolt**

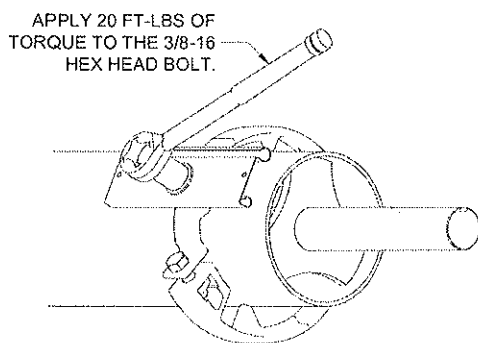

**Figure 8.3 – Fastening Section Attachment with Screw**

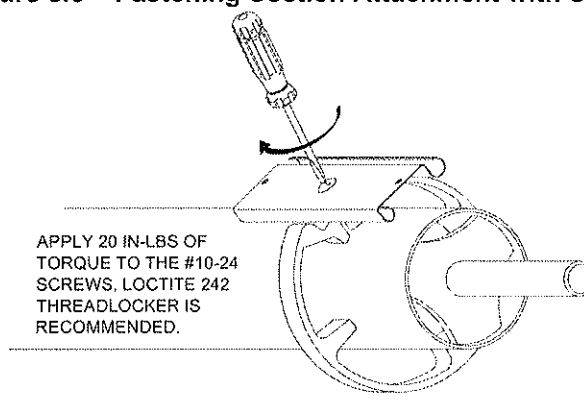

7. Uncoiling a slung curtain using the operator/adjusting wheel:
  - For units with operators, use the hand chain, crank or override feature of the motor to rotate the shaft in the "open" direction. Be sure not to overrun the limits of the motor. The upper motor limit may have to be adjusted to reel the entire curtain onto the shaft. Make sure the adjusting wheel is **not** pinned in place for this operation and that the shaft spins freely, so as to **not** backwind the springs.
  - For push-up units, turns can be added to the adjusting wheel in order to assist in rotating the shaft. Keeping count of the turns added to the spring at this stage will save installation time later.

## Section 8 – Curtain Installation

8. Continue to rotate the shaft, reeling the curtain out of the sling and onto the shaft until the bottom bar reaches the bottom of the bracket.
9. Replace the outer guides.
10. Feed the bottom bar into the guides and lower the curtain until the bottom bar is below the stopper location.
11. Since there is no spring tension holding the curtain open, the curtain may fall if released. If the operator cannot be used to hold the curtain in the open position, place C-clamps or vice grips on the guides just below the bottom bar -or- rest the bottom bar on the slings used to hang the shaft in the previous steps to hold the door open.
12. Replace the stoppers.

Figure 8.4 – Installing the Curtain

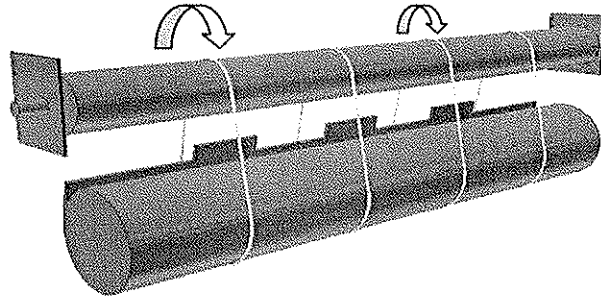

### ▪ Applying Spring Turns:

1. Refer to the job information or markings on the shaft for the number of spring turns required on the unit.
2. To apply spring charge, remove cotter and stop pin from adjusting wheel.
3. Using two ½" diameter (or greater depending on the adjusting wheel) steel rods, approximately 18"-24" long, apply spring torque by inserting both rods into adjustor wheel one above the other.
4. Rotate wheel in a direction of raising the curtain. Maintain applied torque with upper rod, while removing lower rod. RE-insert this rod above the other and continue applying torque one notch at a time using this hand over hand procedure until the specified number of spring turns has been applied. Replace stop pin or bar into adjustor wheel as shown in **Figure 8.5** and insert the cotter pin to hold it in place.
5. The spring should now hold the door in the open position. Remove any devices applied to hold the door in the open position (clamps, slings, vice grip, etc.)
6. Check curtain for ease of operation. If the door operates correctly, skip to the next section, if not, continue to the next step.
7. Final spring tension adjustment, if necessary, should be increased or decreased with the curtain in the fully open position. Insert one [two if necessary] ½" diameter steel rods into adjustor wheel.
8. Remove cotter pin and stop pin from adjustor wheel and begin to increase or decrease tension.
  - To increase tension, rotate the wheel in the direction of raising the curtain.
  - To decrease tension, carefully rotate the wheel in the direction of lowering the curtain.
9. Recheck the balance in 1/8 rotation increments (one notch at a time). Re-insert stop pin and cotter pin.

**Note:** If you have difficulty balancing the door, or the number of turns required to balance the door varies significantly from the quantity provided, contact the **Service Department**.

Section 8 – Curtain Installation

Figure 8.5 – Clamping the Guides, Applying Turns

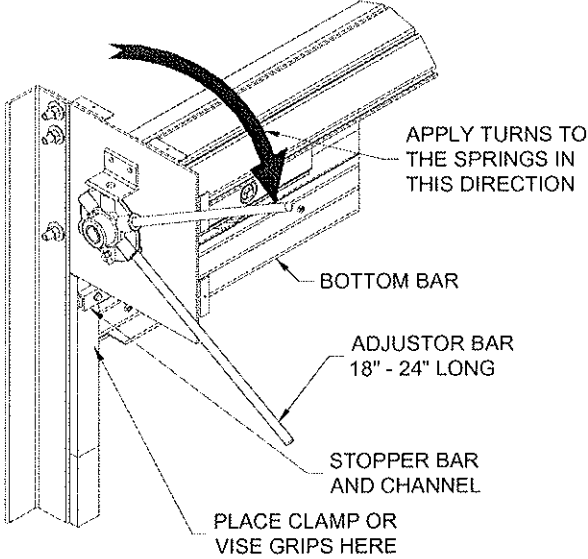
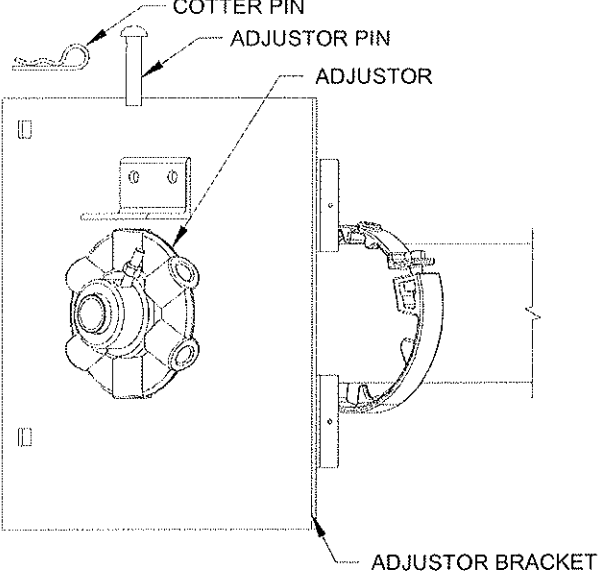

Figure 8.6 – Pinning the Adjusting Wheel



## Section 9 – Hood, Fascia, and Covers

### ▪ Hood Support Installation:

1. Determine what type of hood support is required and how many there will be. See below for different types.
  - a. Hood supports will be noted on the elevation view of the job construction drawings.

**Figure 9.1 – Hood Supports**

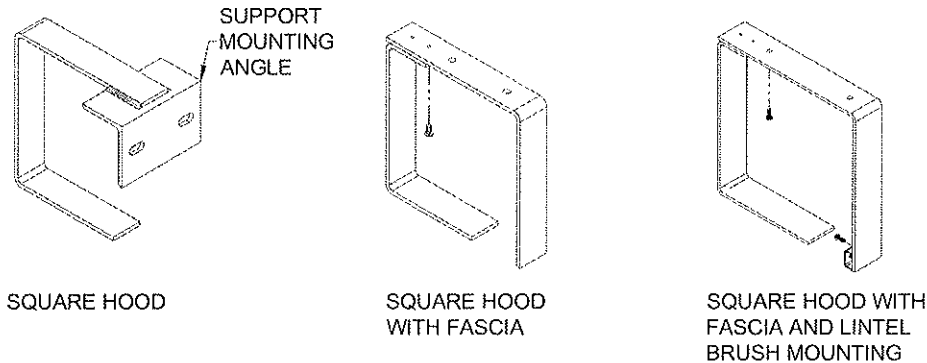

2. If a lintel brush is required, install it at this time. **Figure 9.2** below shows a lintel brush mounting with a hood support with the brush mounting modification.
3. See **Figure 9.3** for mounting the lintel brush channel to the guide.

**Note:** Be sure the lintel brush does not interfere with the bottom bar.

4. Determine where the support(s) will be located between the guides.
  - a. If multiple supports are required, see the job construction drawings to determine the centerline of each.
  - b. If a single support is required, it will be located at the center of the unit.
5. Mark a line on the lintel or ceiling (for units without a lintel) at the centerline of each support.
6. Check the construction at the support locations to be sure it is strong enough to handle the weight of the hood.

**Note:** If the construction is not strong enough, do not proceed until rectified.

**Figure 9.2 – Lintel Brush Channel Mounting to Hood Support**

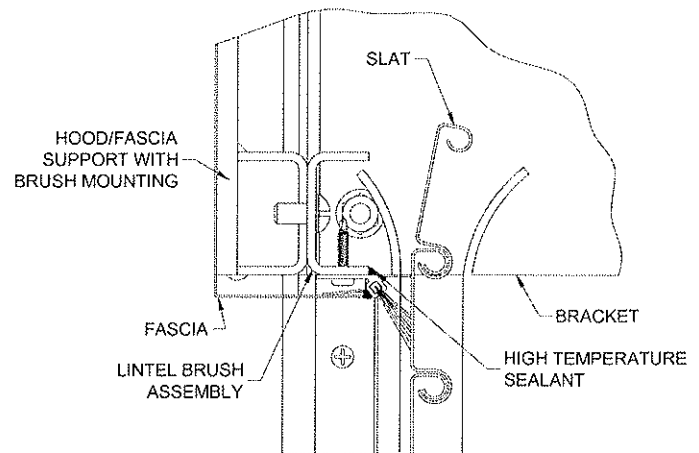

**Figure 9.3 – Lintel Brush Channel Mounting to Guide**

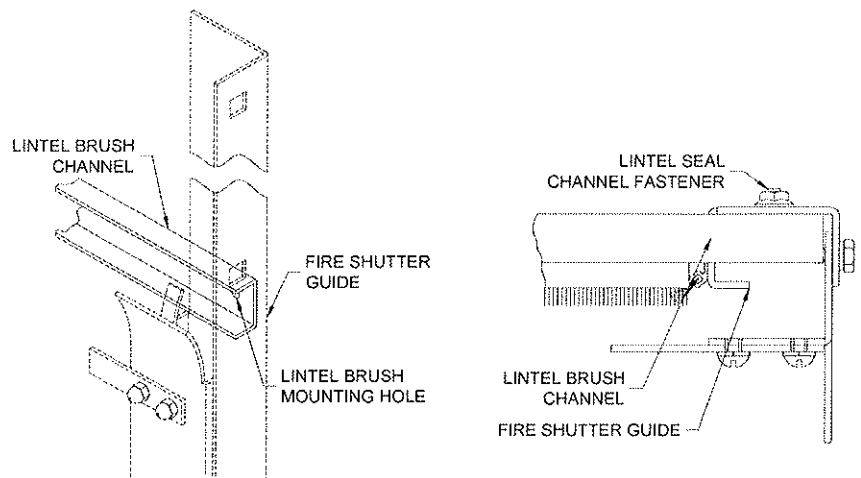

## Section 9 – Hood, Fascia, and Covers

7. Determine where the top of the coil will be.
  - a. This is typically at the top of the wall angle or intermediate angle.
  - b. If there is no wall or intermediate angle, see the job construction drawings for the distance from the bottom of the unit to the top of the coil.
  - c. If there is a ceiling at the top of the coil, skip the next step.
8. Mark a line at the top of the coil at both guides of the unit. Project the lines together to make a continuous line. This will help locate the top of the hood support which will keep the hood level.
9. If there is no lintel/header, the hood support will be located based on the fascia side of the guide.
  - a. If the unit is between jambs with 4 angle guides, a fascia mounting channel is typically provided.
  - b. If the unit is between jambs with 2 angle guides mounted to a tube, a fascia mounting channel is not provided, and the fascia is mounted to the fascia side of the tube.
10. Project a line from the fascia mounting location (fascia mounting channel or fascia side of the tube) from one guide to the other.
11. Mark a line at the support centerline along the fascia line.
12. Prepare the location of the attachment point of the support(s) prior to installing the barrel. This will make installing the support much easier when the time comes to attach it to the lintel/header or ceiling.
  - a. Hold the support in place at the determined location and mark the mounting hole locations.
  - b. Drill holes in the construction.
13. Attach the hood support to the lintel/header or ceiling to be sure the mounting holes were located properly.
14. Remove the hood support and proceed to the **“Barrel and Brackets”** section.
15. Once the barrel, brackets, curtain are installed, and necessary testing was done on the unit, re-install the hood support.

### ▪ **Hood and Fascia Installation:**

1. Check the job construction drawings to see if the hood has multiple parts (such as a two sided hood with a fascia, two sided hood without a top piece, three sided hood with a flared top bead, etc). See **Figure 9.4** for possible hood configurations.
2. Fasten the hood and fascia accordingly using the fasteners provided. Ensure hoods with multiple sections overlap correctly. Square hoods should end flush with the outer edge of the brackets.
3. If there is a hood support provided, the hood sections do **not** overlap at the hood support. They should butt against each other and a hood splice cover is provided to cover the joint, see **Figure 9.5**.

**Note:** *If there is a hood support, pre-drill holes in it to ease hood attachment. A #21 drill size is recommended.*

## Section 9 – Hood, Fascia, and Covers

### Figure 9.4 – Hood Configurations

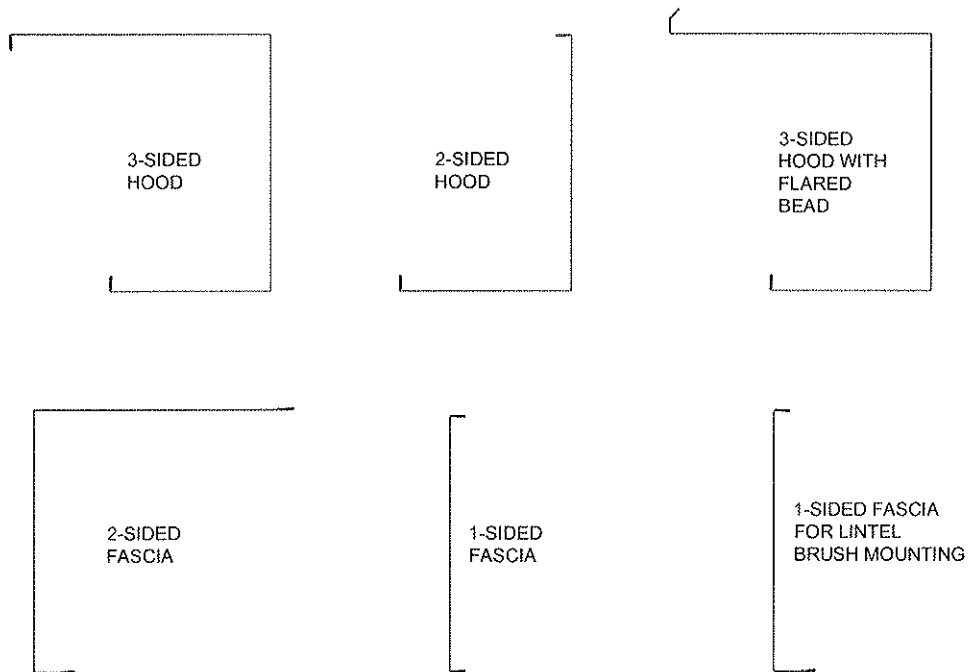

#### ▪ **Cover installation:**

1. Once the unit is installed and operating correctly, the covers can be installed.
2. Hood screws may have to be removed and reinstalled to install covers properly.
3. If an operator or adjuster cover is provided, individual installation instructions are provided with each cover along with the necessary hardware to attach the cover.
4. Once the cover is installed, operate the door a few more times to be sure there is no interference between the moving components inside the cover and the cover itself.
5. If the door is mounted on the exterior of the building, a bead of silicone sealant should be applied around the entire perimeter of the cover, as it will provide additional protection to the door components.

### Figure 9.5 – Hood Splice

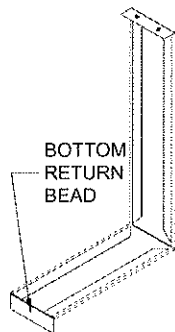

### Figure 9.6 Hood and Cover Screw (#10-16 x 1/2")

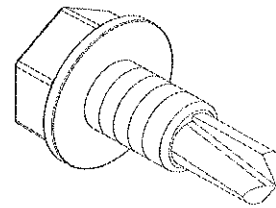

## Section 10 - Torque Specifications

**Table 10.1 – Torque Recommendations for Guide Assembly and Wall Fasteners**

| Bolt size/type  | Torque (ft lbs) <sup>a</sup> |
|---|------------------------------|
| 1/4-20 Grade 2 steel bolt   | 6                            |
| 5/16-18 Black Oxide Socket Cap  | 25                           |
| 3/8-16 18-8 stainless steel bolt  | 20                           |
| 3/8-16 Grade 2 steel bolt   | 20                           |
| 3/8-16 Grade 5 steel bolt   | 31                           |
| 1/2-13 Grade 5 steel bolt   | 75                           |
| 1/2-13 Grade 8 steel bolt   | 107                          |
| 5/8-11 Grade 8 steel bolt   | 212                          |
| 3/4-10 Grade 8 steel bolt   | 376                          |
| <sup>a</sup> The recommended torque for steel bolts is based on a plated bolt that has not been lubricated. |                              |

**Table 10.2 - Torque Recommendations for Solid Masonry Wall Anchors**

| Anchor Size<br>(nominal)   | Manufacturer/Torque (ft lbs) <sup>a</sup> |                   |
|--|---|-------------------|
|  | Simpson Wedge-All                         | Hilti-Kwik Bolt 3 |
| 3/8  | 30  | 20                |
| 1/2  | 60  | 40                |
| 5/8  | 90  | 85                |
| 3/4  | 150                                       | 150               |
| <sup>a</sup> Torque values for grout filled block are different, reference bolt manufacturer for these values. |   |                   |

## Section 11 - Maintenance Schedule

▪ **Maintenance Schedule:**

*Note: If any of the following problems exist, **do not** operate the door until repaired.*

| Component            | What to look for and how often the components must be inspected:   | Weekly | Monthly | Quarterly | What to do if problem exists:  |
|----------------------|--|--------|---------|-----------|--|
| Curtain & Bottom Bar | Are any curtain components damaged (slats, endlocks, etc.)?  | X      |         |           | Contact Service about replacing damaged parts.   |
|                      | Is bottom bar damaged?   | X      |         |           | Contact Service about replacing damaged parts.   |
|                      | Are bottom bar fasteners in place and properly tightened?  |        | X       |           | Fasteners must be inspected/replaced and properly tightened.   |
|                      | Are fasteners attaching curtain to the barrel in place and properly tightened?   |        | X       |           | Fasteners must be inspected/replaced and properly tightened.   |
|                      | Do you notice any hang-ups, jamming or other problems preventing the door from moving smoothly throughout the opening? | X      |         |           | Check for external issues, if none exist, contact Service.   |
|                      | Do you notice any odd or excessive noise when the door is operated?  | X      |         |           | Check for external issues, if none exist, contact Service.   |
|                      | If there is a bottom seal, is it damaged?  |        | X       |           | Contact Service about replacing damaged parts.   |
|                      | If there is locking, does it function properly?  | X      |         |           | Check for external issues, if none exist, contact Service.   |
| Brackets             | Are brackets plumb and perpendicular with wall?  |        |         | X         | Contact Service.   |
|                      | Are bracket fasteners in place and properly tightened?   |        |         | X         | Fasteners must be inspected/replaced and properly tightened.   |
|                      | Do you notice signs of excessive wear on the bearings (i.e. binding, excessive noise, etc.)?                           |        | X       |           | If there is a grease fitting, apply grease, if not, contact Service.   |
|                      | Is adjusting wheel & pin secure?   |        |         | X         | Contact Service.   |
|                      | Is drive chain sufficiently lubricated?  |        |         | X         | Apply chain lube.  |
|                      | Is drive chain in need of tightening?  |        |         | X         | Contact Service for instructions on how to tension the chain.  |
|                      | Is drive or driven sprocket damaged?   |        | X       |           | Contact Service about replacing damaged parts.   |
| Guides               | Are wall fasteners in place and properly tightened?  |        | X       |           | Fasteners must be inspected/replaced and properly tightened.   |
|                      | Are guide assembly fasteners in place and properly tightened?  |        | X       |           | Fasteners must be inspected/replaced and properly tightened.   |
|                      | Is guide gap dimension correct?  |        | X       |           | Check job construction drawings and adjust gap as required. If job construction drawings are not available, contact Service. |
|                      | Are any of the guide parts bent or damaged?  |        | X       |           | Contact Service.   |
|                      | Are stoppers loose, damaged, or missing?   |        | X       |           | Stoppers must be inspected/replaced and properly tightened.  |
| Hood and Fascia      | Is hood/fascia dented or damaged?  |        |         | X         | Remove hood/fascia. Repair if possible. If not leave hood/fascia off and contact Service.                                    |
|                      | Is curtain rubbing against the hood/fascia?  | X      |         |           | Hood/fascia may have been damaged. Contact Service.  |
|                      | Is hood/fascia level?  |        |         | X         | Check fasteners, they may be loose or missing. Replace as soon as possible.  |
|                      | Are guide assembly fasteners in place and properly tightened?  |        | X       |           | Fasteners must be inspected/replaced and properly tightened.   |



### Section 11 - Maintenance Schedule

|                |   |   |   |   |  |
|----------------|---|---|---|---|--|
|                | Is hood support level?  |   |   | X | Check fasteners, they may be loose or missing. Replace as soon as possible.                                    |
| Door operation | Does the door require excessive force to open?  |   | X |   | Check for hang-ups or obstructions. Ensure spring tension is set correctly. Contact Service.                   |
|                | If the door contains locking, does the locking mechanism function properly and securely hold the door in the closed position?                             |   | X |   | Check for damage and other external issues. Contact Service.   |
|                | If there is a sensing edge, does it function properly?  | X |   |   | Cut power and check for loose wires. Contact Service for further instruction.                                  |
| Motor Operator | Are the fasteners attaching the motor-to-the mounting bracket, and mounting bracket-to-the door bracket secure?   |   |   | X | Fasteners must be inspected/replaced and properly tightened. Contact Service for replacement hardware.         |
|                | Are the sprockets properly aligned?   |   |   | X | Realign the sprockets as secure using the set screws. Recheck chain tension.                                   |
|                | Are the sprocket keys properly aligned with sprockets and securely fastened with the set screws?  |   |   | X | Reposition the keys so they fully engage the keyway in the sprocket. Tighten the set screws.                   |
|                | Is the door stopping correctly at the open (before bottom bar contacts the stoppers) and closed (as soon as the bottom bar contacts the floor) positions? |   | X |   | Limits may have to be adjusted in the motor operator. Refer to the operator owner's manual or contact Service. |
|                | Is the operator functioning normally?   |   | X |   | Refer to the <i>Operator Troubleshooting Table</i> on the following page to diagnose the problem.              |

## Section 11 - Maintenance Schedule

▪ **Operator Troubleshooting:**

*Note: If you suspect you are having an issue with your operator, use the following table to determine the potential causes. If the provided solution does not eliminate the issue, or the table does not address your particular problem, contact the Service Department.*

| Component      | Problem   | Potential Cause  | Solution  |
|----------------|---|--|---|
| Motor Operator | Motor Operator does not run when OPEN or CLOSE button is pushed         | The circuit breaker may be flipped or fuse blown.                                | Reset breaker or replace fuse. Contact Service if replacement fuse is needed.   |
|                |   | The thermal overload may be tripped.   | Reset thermal overload.   |
|                |   | Manual interlock switch is open (on units with emergency operator).              | Close manual interlocks.  |
|                |   | External interlock may be opened.  | Close external interlock.   |
|                | Motor operator runs but the door does not move                          | Sprocket key may be missing or drive chain may be broken.                        | Contact Service for repair parts. Install key or replace chain.   |
|                |   | Clutch may be slipping.  | Adjust if possible. Contact Service otherwise.  |
|                | Motor hums but does not run   | Door or drive chain may be jamming.  | Check for hang-ups or obstructions. Try to operate manually. If issue persists, contact Service.                          |
|                |   | Dead phase in 3 phase system.  | Check power supply.   |
|                |   | Brake does not release.  | Check power to brake solenoid.  |
|                |   | Open motor winding.  | Check that all connections are secure.  |
|                | Motor operator runs in wrong direction and limits do not function       | 3 phase operator power supply is out of phase.                                   | Interchange any 2 power leads to unit.  |
|                | Door drifts when motor shuts off  | Brake may be improperly adjusted or broken.                                      | Check brake components. Contact Service for replacement parts or adjust instructions.                                     |
|                | Motor operator does not shut off at full OPEN or at full CLOSE position | Limits may need adjustment.  | Refer to the operator owner's manual to readjust limits.  |
|                |   | Sprocket on limit shaft may be slipping or limit drive chain may be broken.      | Ensure sprocket key is correctly installed and set screws are tightened. Contact Service for replacement chain if broken. |
|                |   | Limit switch may be defective.   | Contact Service.  |
| Limit Switches | Limit switch does not hold setting                                      | Drive chain may be too loose, allowing the chain to jump sprocket teeth.         | Adjust chain to proper tension. Contact Service for additional information.   |
|                |   | Limit nut retainer not engaging slots in limit nuts.                             | Be sure retainer is securely engaged in slots of both limit nuts.   |
|                |   | Limit nuts binding on screw threads, allowing them to jump position on retainer. | Lube screw thread. Check that limit nuts turn freely.   |

## Appendix A – Tube Motors

### ▪ Tube Motor Installation

#### 1. Install operator bracket:

##### a. For 3" Shaft Assemblies (Type 5 & 6 Tube Motors):

Position the angle bracket kit onto the outside face on the operator bracket as shown in **Figure A.1**. The direction of the mounting angle nearest the fascia side depends on the coil size, as shown in **Figure A.1**. Fasten using the (4) 1/4-20 x 3/4 button head screws, and nuts.

**Figure A.1 – Angle Bracket Kit, Type 5 DMI and 6 DMI**

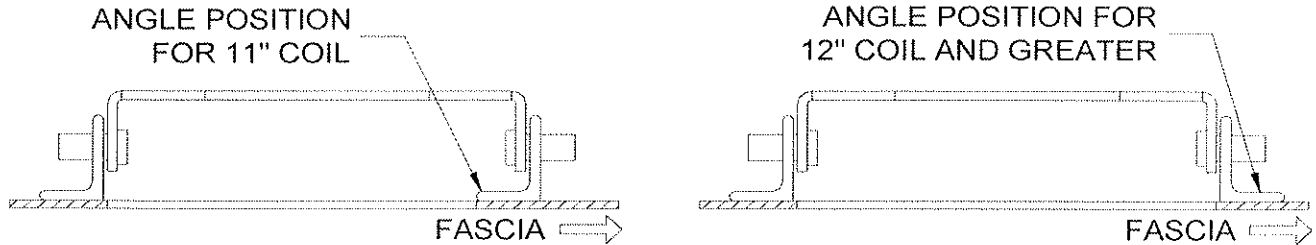

**Note:** The metric sized flat head screws, nuts & external tooth lock washer provided with the angle bracket kit will not be used.

Slide the operator bracket over motor head. Position bracket so that crank shaft is vertical & opposite the wall side. Align the (4) holes in the angle bracket kit with the corresponding holes in the tube motor and fasten using the provided hardware. See **Figure A.2**.

**Figure A.2 – 3" Shaft Assembly**

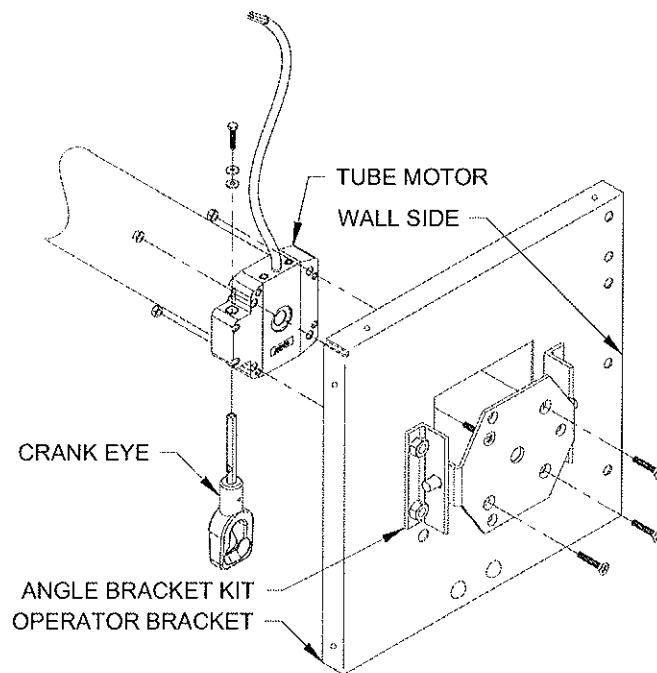

##### b. For 4" Shaft Assemblies (Type 8 Tube Motors):

Reference motor instructions if LH operating is required. Attach lower mounting angle to bracket using provided hardware. Slide operator bracket over motor head, position the lower mounting stud into the lower mounting angle, making sure that the bushing is positioned between the motor and the angle. Install the upper mounting angle and bushing. See **Figure A.3**.

## Appendix A – Tube Motors

2. Locate the idler bracket and cotter pin. Slide the idler bracket onto the idler end shaft until it clears the 1/8" hole. Insert the provided cotter pin into the 1/8" hole and bend (1) leg along end shaft, as to not interfere with the bearing.
3. Install crank eye kit so that the crank eye is towards the floor. Fasten using the provided hardware.
4. Position the assembly on the ground in the opening so that the mounting holes in the brackets are facing the wall. Use this time to ensure that the Tube Motor is oriented as ordered (LH or RH) and that the hand crank is located away from the wall.
5. Lift the entire assembly so that the top of the bracket is flush with the top of the guides. The center of balance for the assembly will be marked as the 'Lifting Point' on the shaft for reference.

### NOTICE

The assembly weight will be biased towards the **operator side**. Use caution when lifting.

6. Move the assembly into position by aligning the mounting holes in the brackets with the holes in the Bracket Mounting Flats at the top of the guides. The brackets should mount on the inside of the mounting members.
7. Verify that the shaft is level and tighten the mounting hardware and set screws in the idler bracket bearing.

**Note:** The operator wiring and limit adjustment information is provided with the operator.

**Tip:** The limit adjustment process for the tube motor can be a time-consuming process, as the reduction throughout the motor sometimes necessitates a large number turns on each limit screw to adjust the position of the limit range. It may prove beneficial to familiarize yourself with the process, or prep the limits in-house, in order to minimize installation time spent in the field.

Figure A.3 – 4" Shaft Assembly

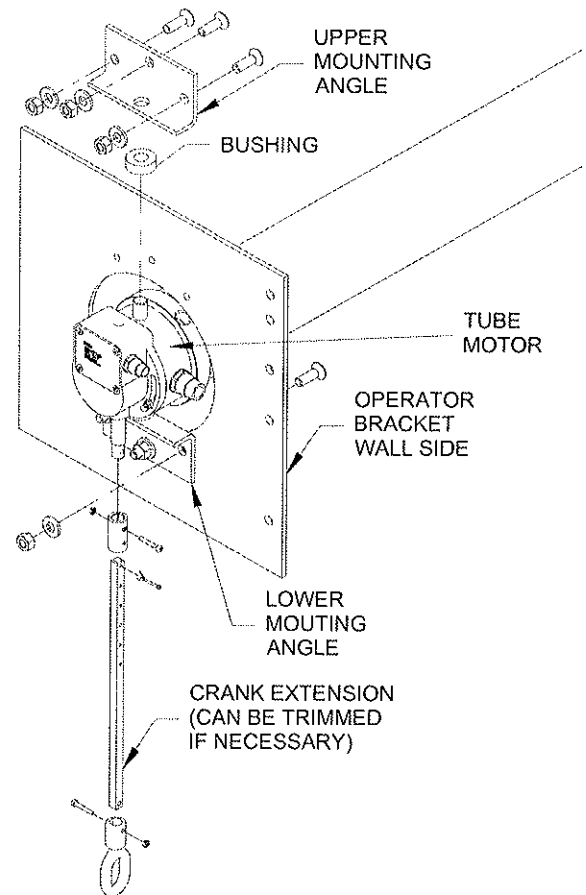

- Return to "Curtain Installation" once operator installation is completed.