

# SINGLE HUNG ORIEL - LARGE MISSILE IMPACT

(SHOWN w/DIFFERENT OPTIONS)

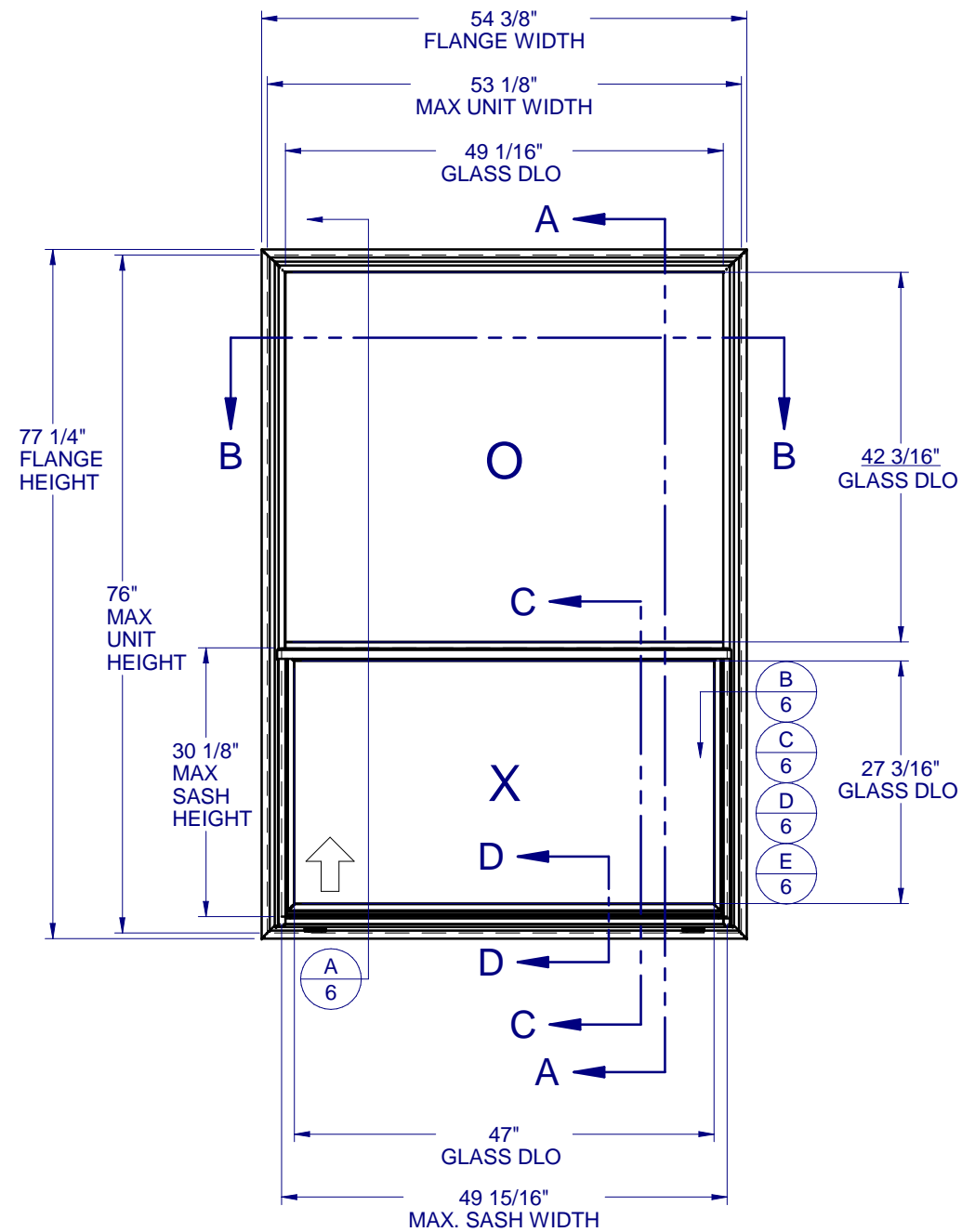

**TABLE OF CONTENTS**

GENERAL NOTES & ELEVATIONS.....1  
 GLAZING DETAILS.....2  
 SECTION VIEWS.....3  
 BOM & EXTRUSIONS.....4  
 ANCHOR SCHEDULE & NOTES.....5  
 INSTALLATION DETAILS.....6

MAX. UNIT SIZE	DESIGN PRESSURE RATING	IMPACT RATING
53-1/8" x 76"	+/- 50 PSF	LARGE MISSILE IMPACT

GENERAL NOTES:

1. THE PRODUCT SHOWN HEREIN IS DESIGNED AND MANUFACTURED TO COMPLY WITH THE FLORIDA BUILDING CODE (FBC), CURRENT EDITION AND IS RATED FOR MISSILE LEVEL D IMPACT USE IN WIND ZONE 3 AREAS AS DEFINED IN ASTM E 1996 PER THE FBC.  
  
THIS PRODUCT MAY NOT BE USED IN THE HIGH VELOCITY HURRICANE ZONE (HVHZ) OR IN ASTM E 1996 WIND ZONE 4 AREAS.
2. GLAZING OPTIONS: (SEE SHEET 2)
3. CONFIGURATIONS: "O/X".
4. DESIGN PRESSURE RATING:  
 -NEGATIVE DESIGN LOADS BASED ON, TESTED PRESSURE AND GLASS TABLES ASTM E-1300-04e01/09.  
 -POSITIVE DESIGN LOADS BASED ON, TESTED PRESSURE, WATER INFILTRATION TEST PRESSURE AND GLASS TABLES ASTM E-1300-04e01/09.
5. ANCHORAGE: THE 33 1/3% STRESS INCREASE HAS NOT BEEN USED IN THE DESIGN OF THIS PRODUCT. SEE SHEET 6 FOR ANCHOR DETAILS. WINDLOAD DURATION FACTOR Cd=1.6 WAS USED FOR WOOD ANCHOR CALCULATIONS.
6. PRODUCT APPROVED FOR IMPACT RESISTANCE. SHUTTERS ARE NOT REQUIRED.
7. ALL FRAMES AND VENTS FULLY WELDED. SMALL JOINT SEAM SEALANT USED AT FIXED MEETING RAIL AND JAMB.
8. SERIES / MODEL DESIGNATION SH-6100.
9. THE DESIGNATION X AND O STAND FOR THE FOLLOWING:  
 X = OPERABLE SASH, O = FIXED SASH
10. SECTION CALLOUTS APPLY TO ALL ELEVATIONS IN A SIMILAR LOCATION.
11. EXTERNAL WEEP SLOT = 1/4 x 1-1/2" LOCATED 5" FROM BOTH ENDS.

**CWS**  
 1900 SW 44TH AVE.  
 OCALA, FLORIDA 34474  
 WWW.CWS.CC

## 6100 PVC SINGLE HUNG ORIEL - IMPACT

PROPRIETARY AND CONFIDENTIAL  
 THE INFORMATION CONTAINED IN THIS DRAWING IS THE SOLE PROPERTY OF CUSTOM WINDOW SYSTEMS, INC. ANY REPRODUCTION IN PART OR AS A WHOLE WITHOUT THE WRITTEN PERMISSION OF CUSTOM WINDOW SYSTEMS, INC IS PROHIBITED.

FLORIDA APPROVAL NO.:  
 18148

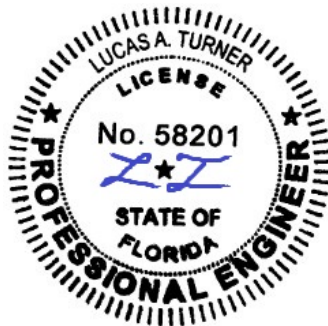

9/13/2023

LUCAS A. TURNER, P.E.  
 FL PE # 58201  
 Turner Engineering & Consulting, Inc.  
 2428 Old Natchez Trc Trl  
 Camden, TN 38320  
 PH. 941-380-1574

SHEET DESCRIPTION:  
**GENERAL NOTES AND ELEVATIONS**

DRAWN BY: MCS	DATE: 8/30/2023
DWG #: CWS-1106	REV.: D
SCALE: 1:20	SHEET 1 OF 6



1900 SW 44TH AVE.  
 Ocala, Florida 34474  
 WWW.CWS.CC

**6100 PVC  
 SINGLE HUNG  
 ORIEL - IMPACT**

PROPRIETARY AND CONFIDENTIAL  
 THE INFORMATION CONTAINED IN  
 THIS DRAWING IS THE SOLE  
 PROPERTY OF CUSTOM WINDOW  
 SYSTEMS, INC. ANY  
 REPRODUCTION IN PART OR AS A  
 WHOLE WITHOUT THE WRITTEN  
 PERMISSION OF CUSTOM WINDOW  
 SYSTEMS, INC IS PROHIBITED.

FLORIDA APPROVAL NO.:  
 18148

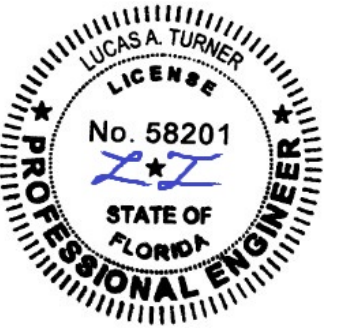

9/13/2023

LUCAS A. TURNER, P.E.  
 FL PE # 58201  
 Turner Engineering &  
 Consulting, Inc.  
 2428 Old Natchez Trc Trl  
 Camden, TN 38320  
 PH. 941-380-1574

SHEET DESCRIPTION:

**GLAZING DETAILS**

DRAWN BY: MCS	DATE: 8/30/2023
DWG #: CWS-1106	REV.: D
SCALE: 1:1	SHEET 2 OF 6

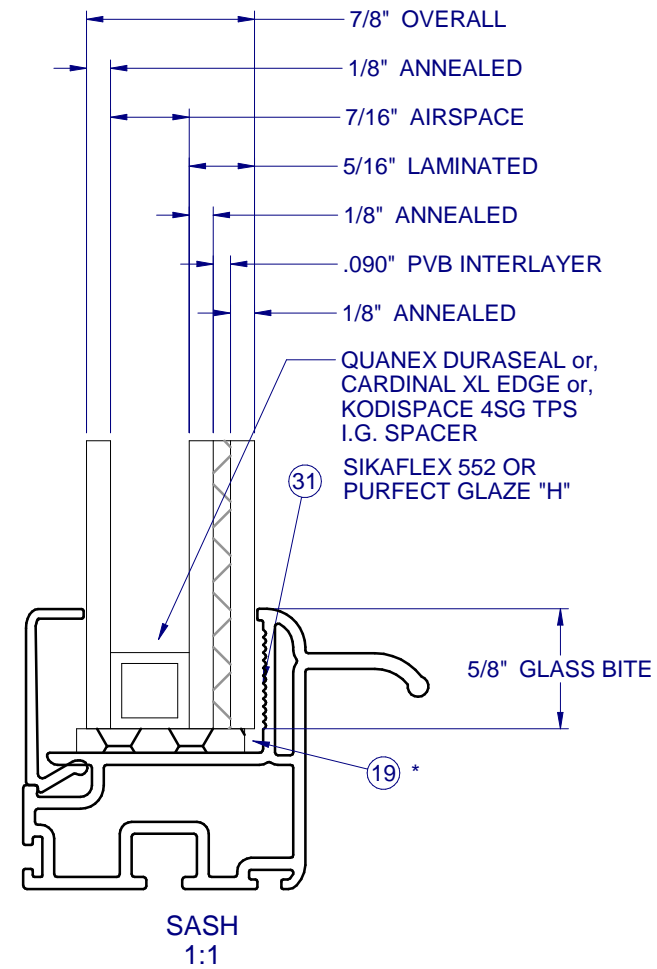
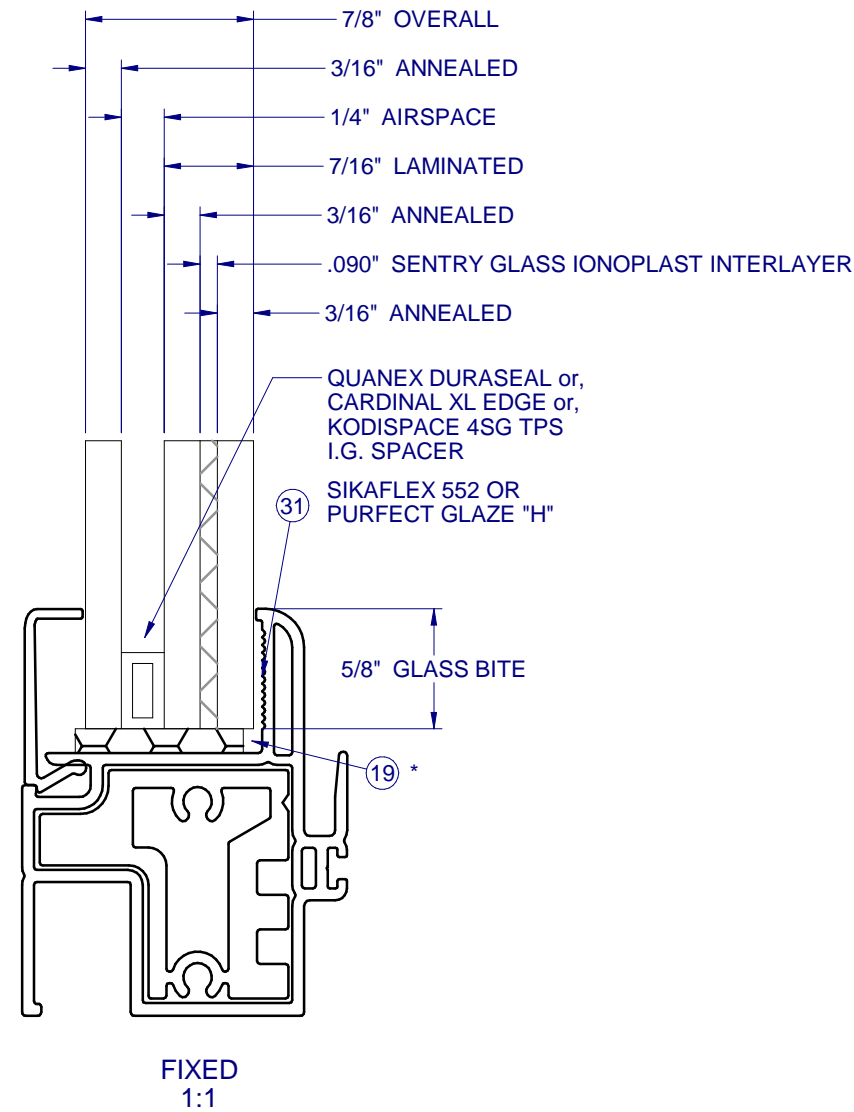



1900 SW 44TH AVE.  
OCALA, FLORIDA 34474  
WWW.CWS.CC

### 6100 PVC SINGLE HUNG ORIEL - IMPACT

PROPRIETARY AND CONFIDENTIAL  
THE INFORMATION CONTAINED IN  
THIS DRAWING IS THE SOLE  
PROPERTY OF CUSTOM WINDOW  
SYSTEMS, INC. ANY  
REPRODUCTION IN PART OR AS A  
WHOLE WITHOUT THE WRITTEN  
PERMISSION OF CUSTOM WINDOW  
SYSTEMS, INC IS PROHIBITED.

FLORIDA APPROVAL NO.:

18148

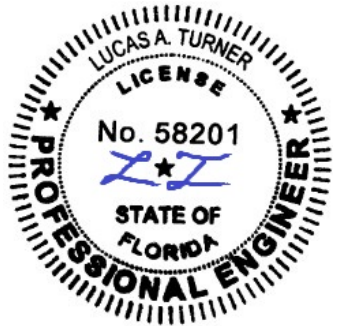

9/13/2023

LUCAS A. TURNER, P.E.  
FL PE # 58201  
Turner Engineering &  
Consulting, Inc.  
2428 Old Natchez Trc Trl  
Camden, TN 38320  
PH. 941-380-1574

SHEET DESCRIPTION:

#### SECTION VIEWS

DRAWN BY:	DATE:
MCS	8/30/2023
DWG #:	REV.:
CWS-1106	D
SCALE:	SHEET
1:2	3 OF 6

INTERIOR

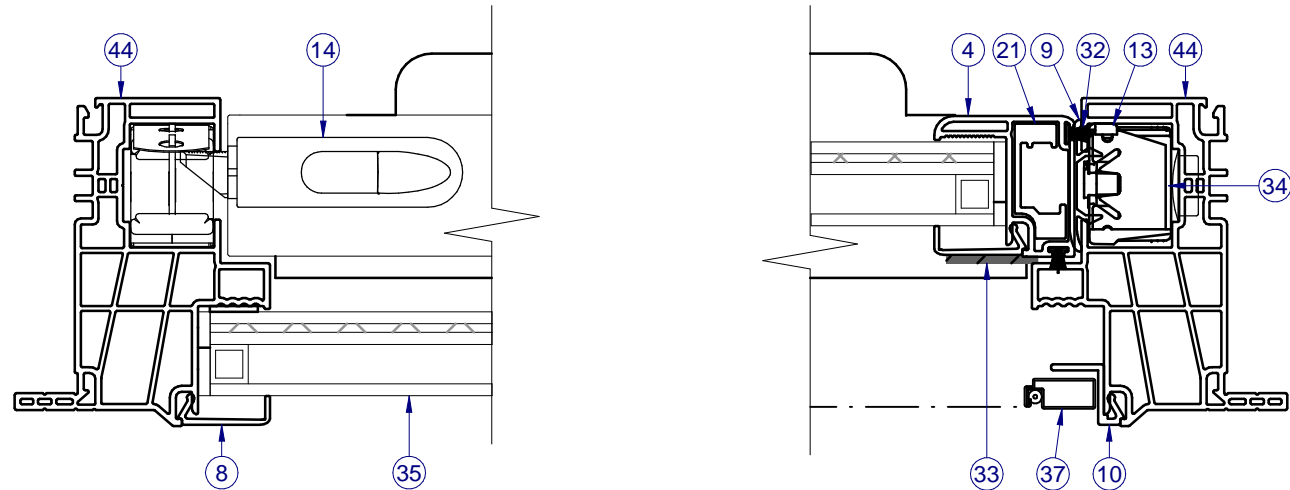

SECTION B-B

NOTE: LEFT SIDE SHOWS FIXED SECTION VIEW,  
RIGHT SIDE SHOWS SASH SECTION VIEW.

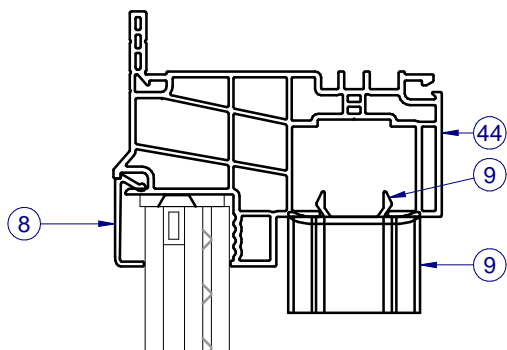

SECTION A-A

INTERIOR

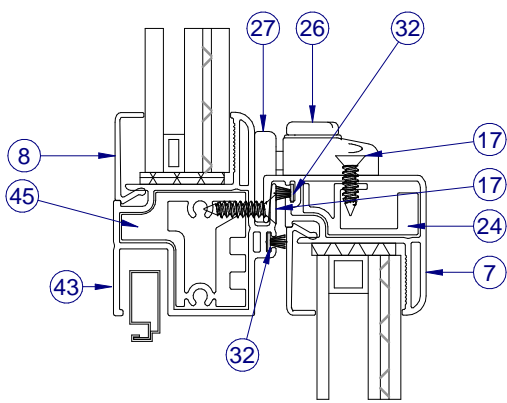

SECTION C-C  
ALT MTG RAIL  
AND SLOPE SILL

INTERIOR

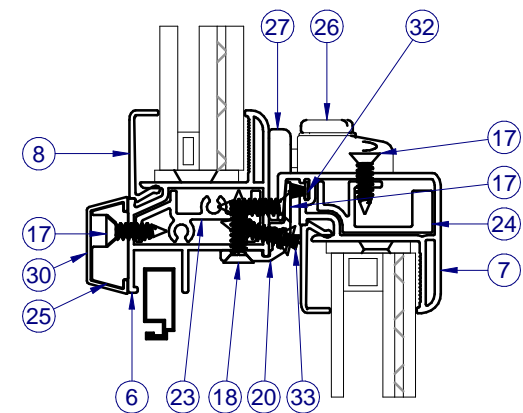

SECTION D-D  
ALT 562 POCKET UNI-FRAME

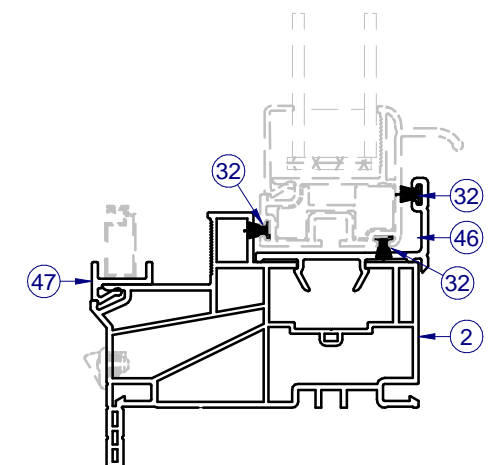

NOTES:  
- FIN FRAME AVAILABLE FOR BOTH UNI-FRAME  
AND STANDARD FRAME TYPES.  
- 880 BALANCERS AND DEEP POCKET UNI-FRAME  
(H-6193) REQUIRED FOR LARGER SASHES. (NOT  
SHOWN IN SECTION B-B)

NOTE: ITEMS NOT SHOWN FOR CLARITY: 38-41

ITEM	PART	DESCRIPTION	MATERIAL
1	H-6125	HEAD, OUTERFRAME	PVC
2	H-6125	JAMBS, OUTERFRAME	PVC
3	H-6126	SILL, OUTERFRAME	PVC
4	H-6132	SASH SIDE RAIL	PVC
5	H-6136	SASH BOTTOM RAIL	PVC
6	H-6137	FIXED MEETING RAIL	PVC
7	H-6138	SASH TOP RAIL	PVC
8	S-6141	GLAZING BEAD	PVC
9	S-5592	SASH STOP, ADEPT, SH/DH, CROSSOVER,	PVC
10	S-6143	SCREEN ADAPTOR	PVC
11	P-5085	WSTP, QLON BULB VINYL	
12	P-5471	WSTP, QLON BULB VINYL	
13		BALANCERS - CONSTANT FORCE RT 880	
14	P-5392	SASH TILT LATCH	NYLON
15	P-5393	PIVOT CARRIER	NYLON
16	P-5396	PIVOT BAR	SS
17	P-3515	#8 x 5/8 PHIL FLAT WHITE SMS	STEEL
18	P-4146	#8 X 3/4 PHIL FLAT tek	STEEL
19	P-5612	Setting Block, .12 x 1 x 2	RUBBER
20	S-2001	INTERLOCK RAIL	ALUM
21	S-2006	REINF, SASH SIDE RAIL, HD	ALUM
22	S-2007	REINF, BOTTOM RAIL	ALUM
23	S-2008	REINF, FMR	ALUM
24	S-2009	REINF, TOP RAIL	ALUM
25	S-2011	REINF, EXTERNAL	ALUM
26	P-3783	IMPACT LOCKS	NYLON
27	P-5557	Keeper, IMPACT, PVC (610/6100)	NYLON
28	P-5420	WEEP COVER	NYLON
29	P-5397	FMR ENDCAP	NYLON
30	P-5400	COVER, FMR REINF.	PVC
31		SIKA FLEX 552 OR PURFECT GLAZE 'H'	SILICONE
32	P-3305	WSTP., .270 X 187, SOFT TOUCH FIN	
34	P-5588	HOLE PLUG	NYLON
35	GLASS	SEE SHEET 2	
36	P-4638	#8 X 2-1/2 PHIL TRUSS tek	STEEL
37	P-3218	SCREEN FRAME	ALUM
38	P-4754	SCREEN CORNER KEY	NYLON
39	P-5576	Screen Spline, .125" Black PE Ribbed	
40	P-4755	SCREEN CORNER KEY (Rollform scrn 1"	
41	P-3195	SPRING, NO HOLE TENSION C-8400	
43	H-6157	HD FIXED MEETING RAIL	PVC
44	H-6193	UNI-FRAME, 880 BALANCERS	PVC
45	H-2115	REINF, HD FMR	ALUM
46	S-6239	UNI-FRAME SILL POCKET INSERT	PVC
47	S-6217	UNI-FRAME SCREEN RETAINER	PVC

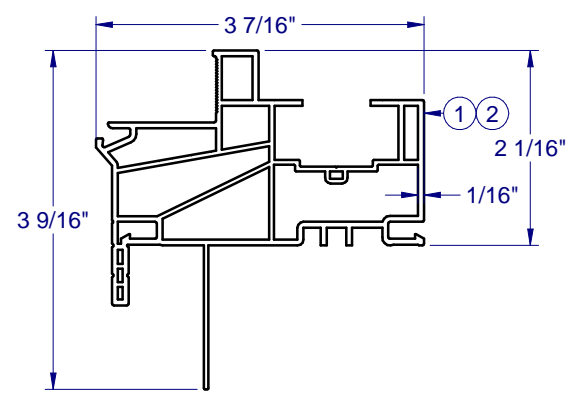

PVC FRAME HEAD & JAMB  
H-6125

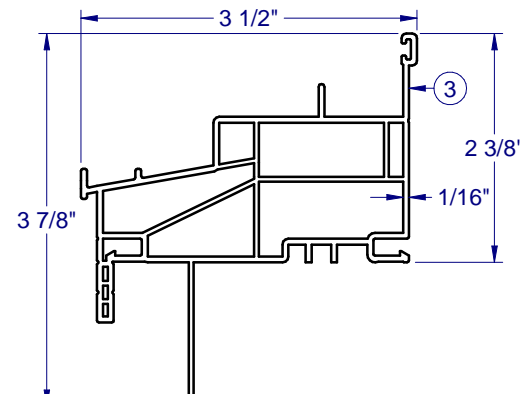

PVC FRAME SILL  
H-6126

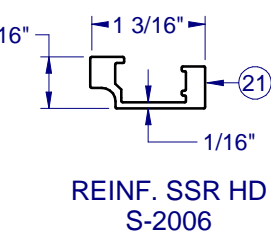

REINF. SSR HD  
S-2006

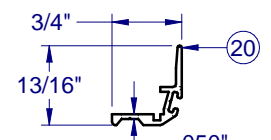

INTERLOCK  
S-2001

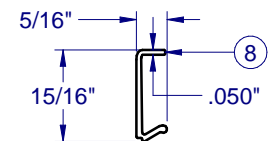

PVC GLAZING BEAD  
S-6141

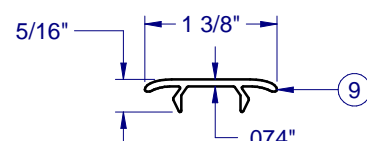

PVC SASH STOP  
S-5592

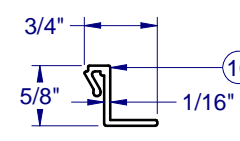

PVC SCREEN ADAPTOR  
S-6143

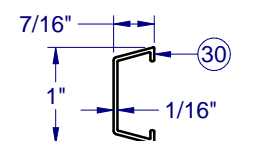

PVC COVER, FMR REINF.  
P-5400

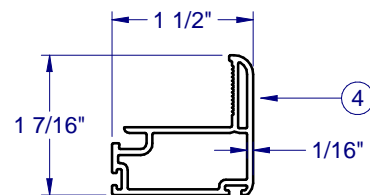

PVC SIDE RAIL  
H-6132

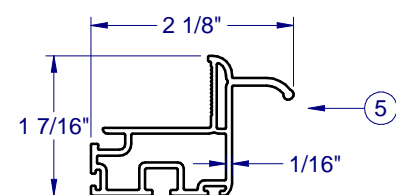

PVC SASH BTM RAIL  
H-6136

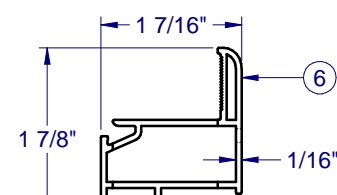

PVC SASH FMR  
H-6137

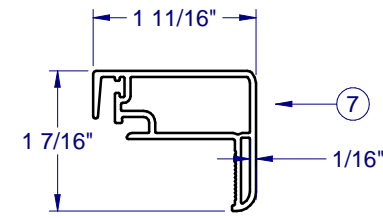

PVC SASH TOP RAIL  
H-6138

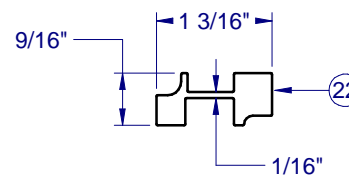

REINF. BTM RAIL  
S-2007

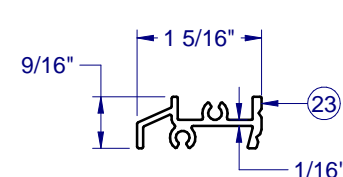

REINF. FMR  
S-2008

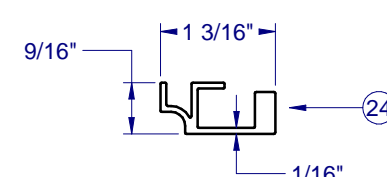

REINF. TOP RAIL  
S-2009

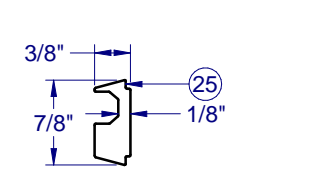

REINF. EXTERNAL  
S-2011

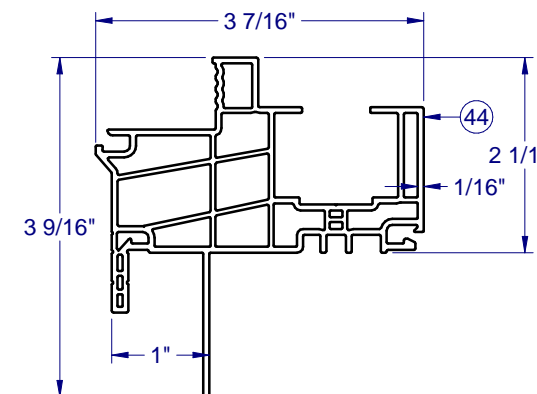

PVC FRAME  
H-6193

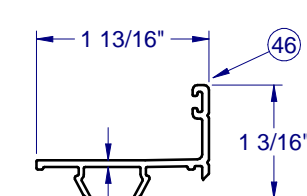

PVC SILL POCKET INSERT  
S-6239

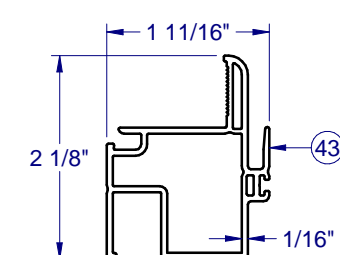

PVC HD FMR  
H-6157

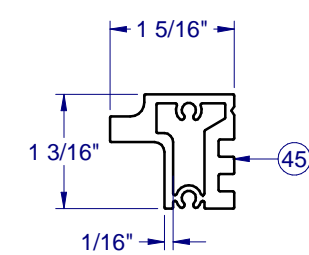

REINF. HD FMR  
H-2115  
6005A-T5

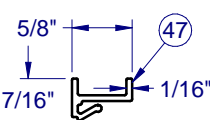

PVC SCREEN RETAINER  
S-6217

FRAME CORNER CONSTRUCTION

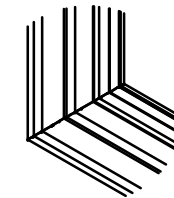

CORNER WELD (ALL SIDES)  
1:8

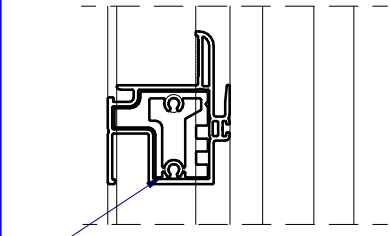

FIXED MEETING RAIL  
SCREWED TOGETHER WITH  
OUTERFRAME  
1:8



1900 SW 44TH AVE.  
OCALA, FLORIDA 34474  
WWW.CWS.CC

6100 PVC  
SINGLE HUNG  
ORIEL - IMPACT

PROPRIETARY AND CONFIDENTIAL  
THE INFORMATION CONTAINED IN  
THIS DRAWING IS THE SOLE  
PROPERTY OF CUSTOM WINDOW  
SYSTEMS, INC. ANY  
REPRODUCTION IN PART OR AS A  
WHOLE WITHOUT THE WRITTEN  
PERMISSION OF CUSTOM WINDOW  
SYSTEMS, INC IS PROHIBITED.

FLORIDA APPROVAL NO.:  
18148



9/13/2023

LUCAS A. TURNER, P.E.  
FL PE # 58201  
Turner Engineering &  
Consulting, Inc.  
2428 Old Natchez Trc Trl  
Camden, TN 38320  
PH. 941-380-1574

SHEET DESCRIPTION:

BOM AND EXTRUSIONS

DRAWN BY: MCS	DATE: 8/30/2023
DWG #: CWS-1106	REV.: D
SCALE: 1:2	SHEET 4 OF 6

NOTE: ALL ALUMINUM EXTRUSIONS ARE 6063-T6 UNLESS OTHERWISE NOTED.



1900 SW 44TH AVE.  
OCALA, FLORIDA 34474  
WWW.CWS.CC

### 6100 PVC SINGLE HUNG ORIEL - IMPACT

PROPRIETARY AND CONFIDENTIAL  
THE INFORMATION CONTAINED IN  
THIS DRAWING IS THE SOLE  
PROPERTY OF CUSTOM WINDOW  
SYSTEMS, INC. ANY  
REPRODUCTION IN PART OR AS A  
WHOLE WITHOUT THE WRITTEN  
PERMISSION OF CUSTOM WINDOW  
SYSTEMS, INC IS PROHIBITED.

FLORIDA APPROVAL NO.:  
18148

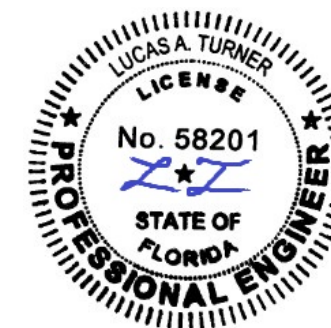

9/13/2023

LUCAS A. TURNER, P.E.  
FL PE # 58201  
Turner Engineering &  
Consulting, Inc.  
2428 Old Natchez Trc Trl  
Camden, TN 38320  
PH. 941-380-1574

SHEET DESCRIPTION:  
ANCHOR SCHEDULE AND  
NOTES

DRAWN BY: MCS	DATE: 8/30/2023
DWG #: CWS-1106	REV.: D
SCALE: 1:25	SHEET 5 OF 6

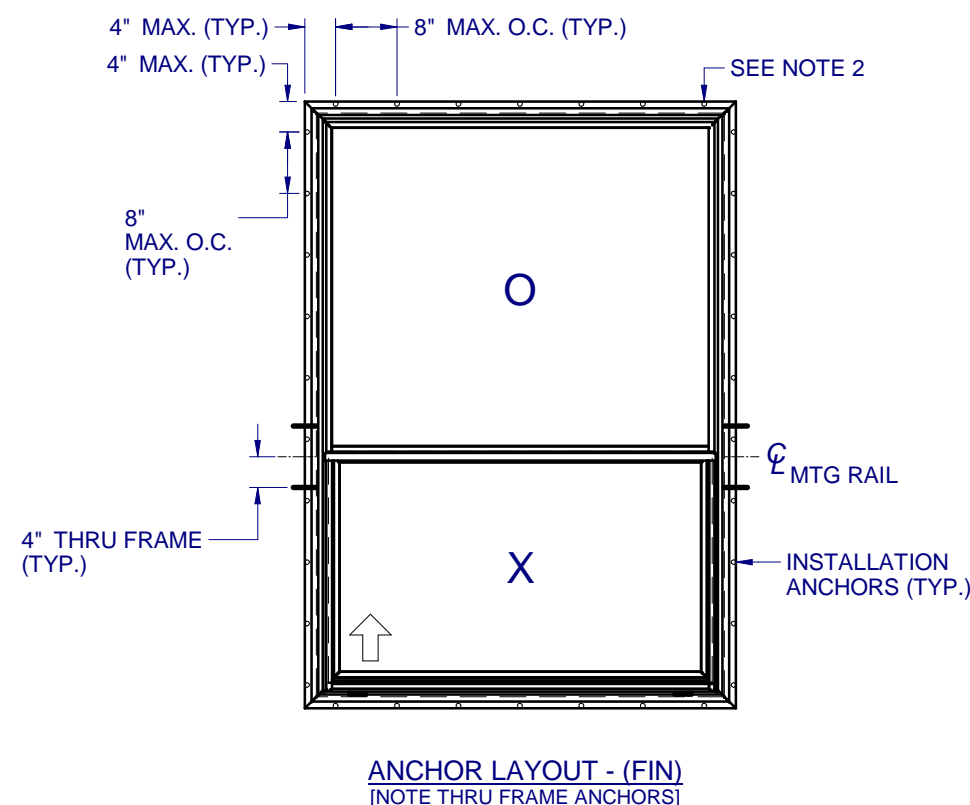
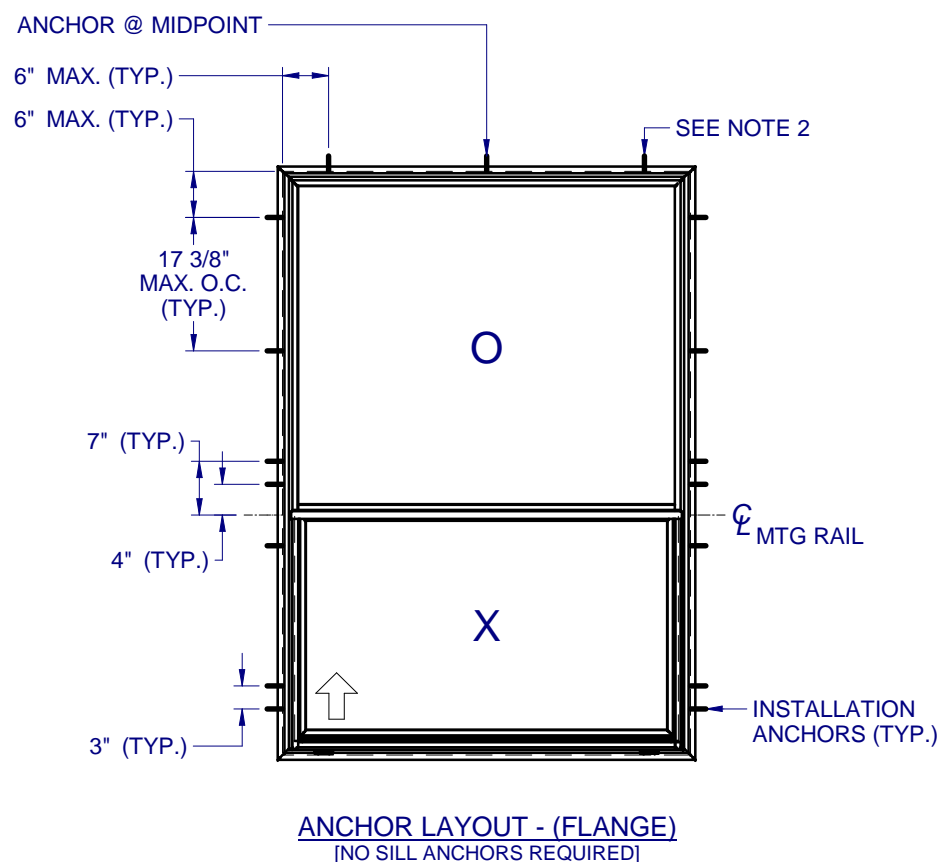

NOTES:

1. INSTALL ONE ANCHOR AT EACH INSTALLATION LOCATION.
2. SHIM AS REQ AT EACH INSTALLATION ANCHOR USING LOAD BEARING SHIMS. MAX. ALLOWABLE SHIM STACK TO BE 1/4". USE SHIMS WHERE SPACE GREATER THAN 1/16" IS PRESENT. LOAD BEARING SHIMS SHALL BE CONSTRUCTED OF HIGH DENSITY PLASTIC OR BETTER. WOOD SHIMS ARE NOT ALLOWED.
3. ANCHOR TYPE, SIZE, SPACING AND EMBEDMENT SHALL BE AS SPECIFIED IN THESE DRAWINGS, SEE TABLE 1, SHEET 6.
4. ALL INSTALLATION ANCHORS MUST BE MADE OF OR PROTECTED WITH A CORROSION RESISTANT MATERIAL OR COATING. DISSIMILAR METALS OR MATERIALS IN CONTACT WITH PRESSURE TREATED WOOD MUST BE PROTECTED TO PREVENT REACTION.
5. INSTALLATION ANCHORS SHALL BE IN ACCORDANCE WITH ANCHOR MANUFACTURER'S INSTALLATION INSTRUCTIONS, AND ANCHORS SHALL NOT BE USED IN SUBSTRATES WITH STRENGTHS LESS THAN THE MINIMUM SPECIFIED IN TABLE 1, SHEET 6.
6. ANCHOR EMBEDMENT TO SUBSTRATE SHALL BE BEYOND WALL DRESSING OR STUCCO. FOR CONCRETE/CMU OPENINGS, EMBEDMENT SHALL BE BEYOND WOOD BUCKS, IF USED, INTO SUBSTRATE. INSTALLATIONS INTO SOLID CONCRETE OR GROUT-FILLED CMU MAY INCLUDE BUT DO NOT REQUIRE 1X WOOD BUCKS BETWEEN THE PRODUCT AND SUBSTRATE. INSTALLATIONS INTO HOLLOW CMU REQUIRE THE USE OF 1X WOOD BUCKS BETWEEN THE PRODUCT AND SUBSTRATE.
7. A MINIMUM CENTER-TO-CENTER SPACING SHALL BE MAINTAINED BETWEEN ALL FASTENERS: 3" FOR MASONRY, 1" FOR WOOD AND METAL.
8. WOOD OR MASONRY OPENINGS, BUCKS AND BUCK FASTENERS SHALL BE PROPERLY DESIGNED BY THE ARCHITECT OR ENGINEER OF RECORD AND INSTALLED TO TRANSFER WIND LOADS TO THE STRUCTURE. SUBSTRATES SHALL MEET THE MINIMUM STRENGTH REQUIREMENTS AS SHOWN IN TABLE 1, SHEET 6. CONCRETE AND MASONRY SUBSTRATES MAY NOT BE CRACKED.
9. SEALING AND FLASHING STRATEGIES FOR OVERALL WATER RESISTANCE OF INSTALLATION SHALL BE DONE BY OTHERS FOLLOWING THE CURRENT VERSION OF THE REFERENCE DOCUMENTS: FMA/AAMA 100(FIN WINDOWS), FMA/AAMA 200(FLANGE WINDOWS), FMA/WDMA 250(BOX WINDOWS), FMA/AAMA/WDMA 300(EXTERIOR DOORS)

### 6100 PVC SINGLE HUNG ORIEL - IMPACT

PROPRIETARY AND CONFIDENTIAL  
THE INFORMATION CONTAINED IN THIS DRAWING IS THE SOLE PROPERTY OF CUSTOM WINDOW SYSTEMS, INC. ANY REPRODUCTION IN PART OR AS A WHOLE WITHOUT THE WRITTEN PERMISSION OF CUSTOM WINDOW SYSTEMS, INC IS PROHIBITED.

FLORIDA APPROVAL NO.:  
18148



9/13/2023

LUCAS A. TURNER, P.E.  
FL PE # 58201  
Turner Engineering & Consulting, Inc.  
2428 Old Natchez Trc Trl  
Camden, TN 38320  
PH. 941-380-1574

SHEET DESCRIPTION:

#### INSTALLATION DETAILS

DRAWN BY:	DATE:
MCS	8/30/2023
DWG #:	REV.:
CWS-1106	D
SCALE:	SHEET
1:2	6 OF 6

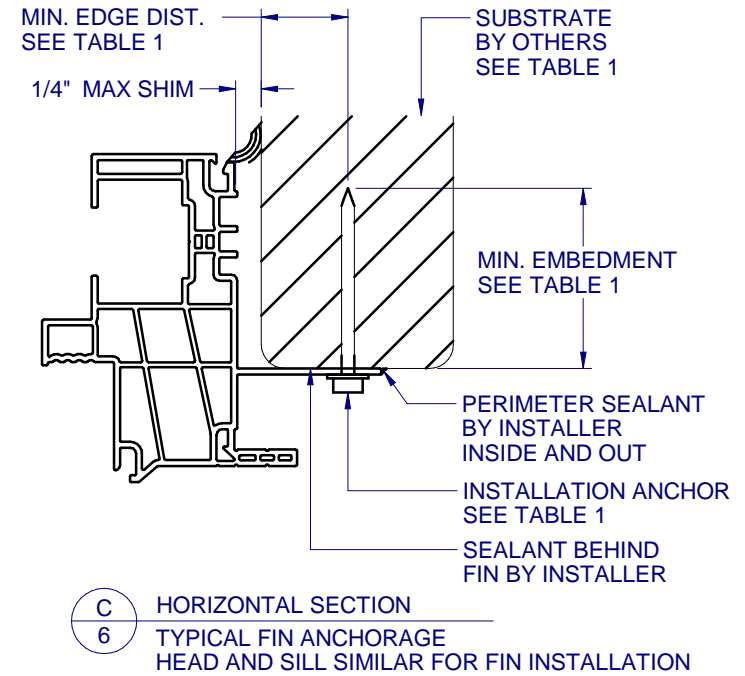
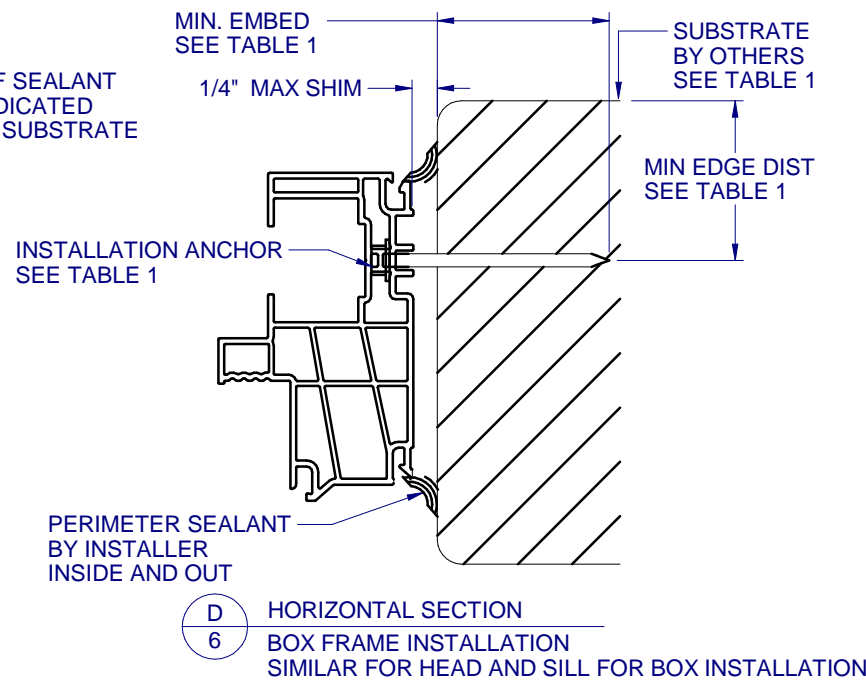
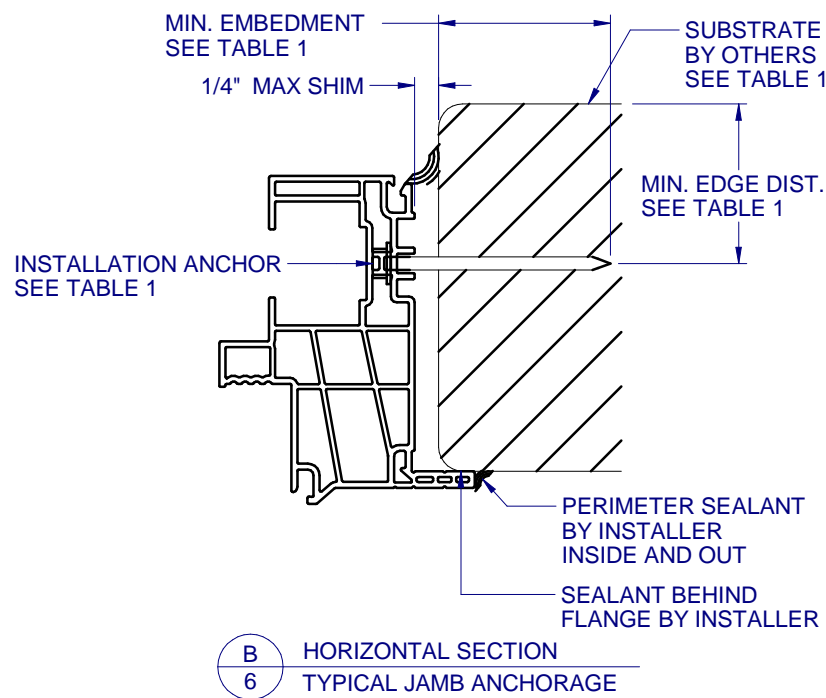
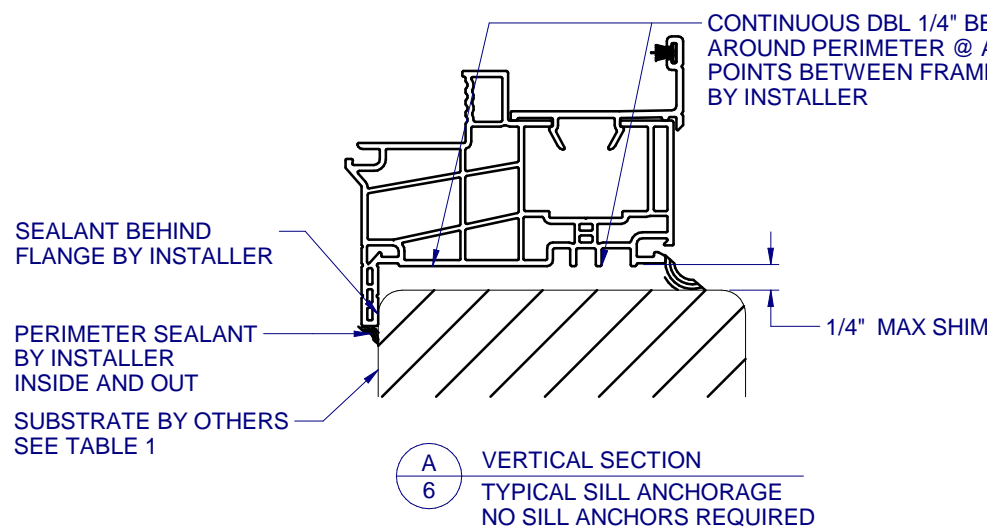
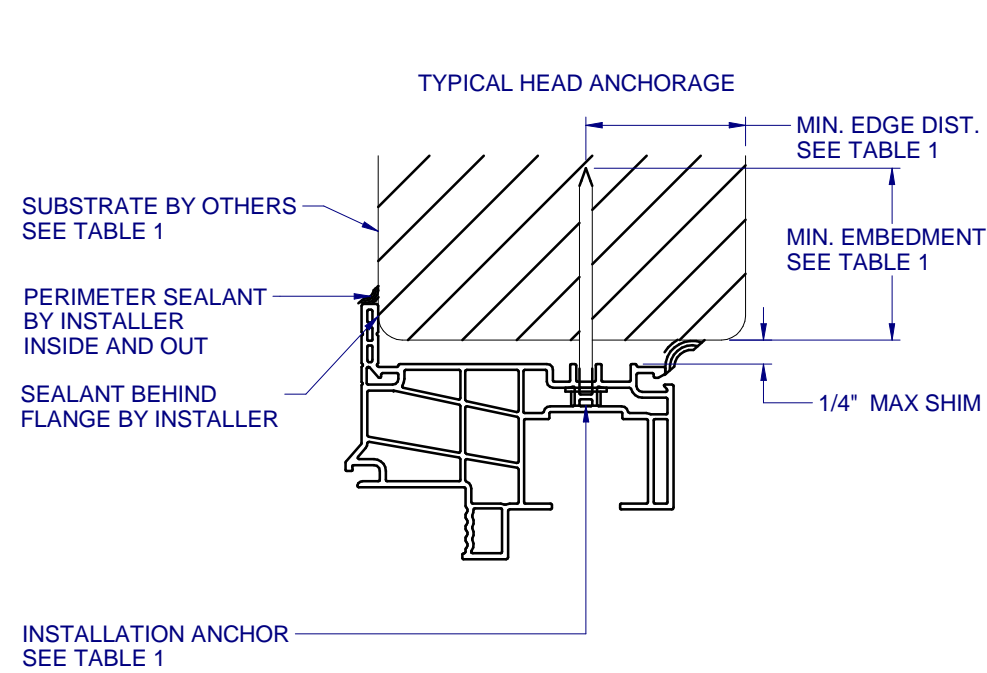

NOTE: ADDITIONAL THRU-FRAME ANCHORS (AS SHOWN IN DET. B/6) REQ'D AT MTG RAIL. SEE SHEET 5 ANCHOR LAYOUT.

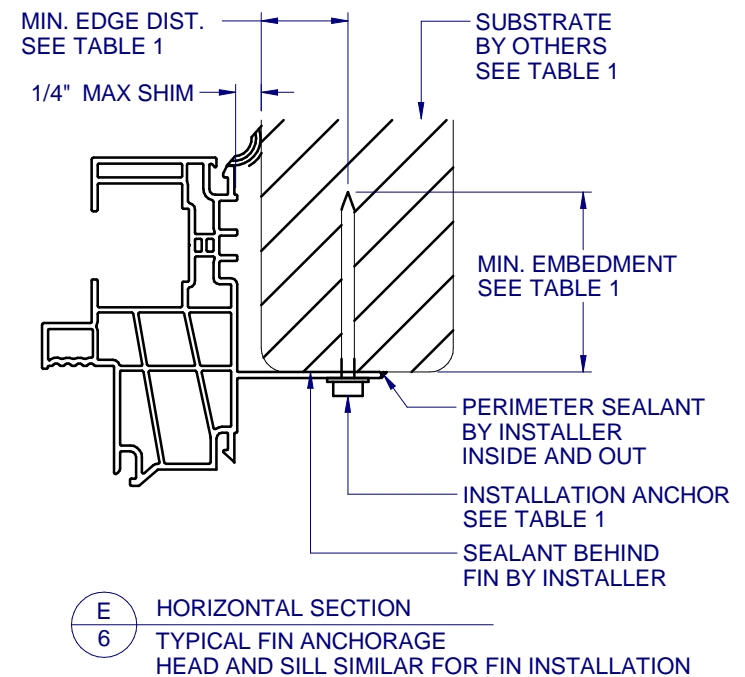

NOTE: ADDITIONAL THRU-FRAME ANCHORS (AS SHOWN IN DET. B/6) REQ'D AT MTG RAIL. SEE SHEET 5 ANCHOR LAYOUT.

FLANGE REMOVAL NOTE: PARTIALLY OR FULLY REMOVING THE FLANGE, UP TO AND INCLUDING A BOX-FRAME APPLICATION IS ACCEPTABLE PROVIDED:

- MIN. 1/4" FILLET OF CONSTRUCTION-GRADE ADHESIVE CAULK IS APPLIED INSIDE AND OUT, FULL PERIMETER, BY INSTALLER.
- PRODUCT ANCHORAGE IS IN ACCORDANCE WITH REQUIREMENTS AS SHOWN FOR FLANGE WINDOWS.

TABLE 1: APPROVED INSTALLATION FASTENERS

FRAME TYPE	SUBSTRATE TYPE	ANCHOR TYPE	MIN. EMBEDMENT	MIN. EDGE DIST.
FLANGE	CONCRETE (2.0 KSI MIN.)	3/16" ITW TAPCON	1"	1-1/8"
FLANGE	HOLLOW OR GROUT-FILLED CMU (117 PCF MIN.)	3/16" ITW TAPCON	1"	2"
FLANGE	CONCRETE (3.05 KSI MIN.)	3/16" DEWALT ULTRACON+	1-3/4"	1"
FLANGE	HOLLOW OR GROUT-FILLED CMU (ASTM C-90)	3/16" DEWALT ULTRACON+	1-1/4"	2-1/2"
FLANGE	2X MIN. SOUTHERN PINE (G=0.55)	3/16" ITW TAPCON OR DEWALT ULTRACON+	1-3/8"	7/8"
FLANGE	2X MIN. SOUTHERN PINE (G=0.55)	#10 WOOD SCREW	1-3/8"	7/8"
FLANGE	16 GAUGE (0.060") MIN. STEEL STUD (33 KSI YIELD MIN)	#10-16 HILTI KWIK-FLEX OR ITW TEKS SELF-DRILLING SCREW	FULL THREAD THRU 0.060"	7/16"
FLANGE	1/8" ALUM. (6063-T5 MIN.) OR 1/8" STEEL (33 KSI MIN.)	#10 GRADE 5 SELF-TAPPING / DRILLING SCREW	FULL THREAD THRU 0.125"	7/16"
FIN	2X MIN. SOUTHERN PINE (G=0.55)	#10 WOOD SCREW	1-1/2"	1/2"

NOTE: UNIF-FRAME OPTIONS NOT SHOWN.