

REVISIONS			
REV	DESCRIPTION	DATE	APPROVED
A	REVISED INSTALLATION DETAILS	06/23/15	R.L.
B	REVISED PER NEW REQUIREMENTS	01/10/18	R.L.

NOTES:

1. THE PRODUCT SHOWN HEREIN IS DESIGNED AND MANUFACTURED TO COMPLY WITH REQUIREMENTS OF THE FLORIDA BUILDING CODE.
2. WOOD FRAMING TO BE DESIGNED AND ANCHORED TO PROPERLY TRANSFER ALL LOADS TO STRUCTURE. FRAMING IS THE RESPONSIBILITY OF THE ARCHITECT OR ENGINEER OF RECORD.
3. ALLOWABLE STRESS INCREASE OF 7/3 WAS NOT USED IN THE DESIGN OF THE PRODUCT SHOWN HEREIN. WIND LOAD DURATION FACTOR $C_d=1.6$ WAS USED FOR WOOD ANCHOR CALCULATIONS.
4. APPROVED IMPACT PROTECTIVE SYSTEM IS NOT REQUIRED FOR THIS PRODUCT IN WIND BORNE DEBRIS REGIONS UP TO WIND ZONE 3.
5. DESIGN PRESSURE AND INSTALLATION DETAILS SHOWN IN THIS DOCUMENT APPLY ONLY TO MULLION. WINDOWS MUST BE APPROVED UNDER SEPARATE APPROVAL.
6. SINGLE WINDOWS TO BE MULLED ARE NOT LIMITED TO THOSE SHOWN IN THIS DRAWING. WINDOWS ATTACHED TO MULLION MUST HAVE SEPARATE APPROVAL.
7. DESIGN PRESSURE OF MULLED UNIT SHALL BE CONTROLLED BY THE LESSER DESIGN PRESSURE OF THE MULLION OR THE INDIVIDUAL WINDOW OR DOOR UNIT.
8. UNITS MAY BE MULLED TOGETHER INDEFINITELY AS LONG AS SINGLE UNIT WIDTH AND HEIGHT ARE NOT EXCEEDED AND MULLION IS ANCHORED AS SHOWN HEREIN.
9. MULLION VERTICAL INSTALLATION IS SHOWN, MULLION MAY BE USED IN HORIZONTAL APPLICATIONS AS LONG AS DIMENSIONS INDICATED HEREIN ARE NOT EXCEEDED AND MULLION IS ANCHORED ACCORDING TO THIS DOCUMENT.

ANCHORING NOTES:

1. FOR ANCHORING INTO WOOD FRAMING OR 2X BUCK USE #10 WOOD SCREW WITH SUFFICIENT LENGTH TO ACHIEVE A 1 3/8" MINIMUM EMBEDMENT. LOCATE ANCHORS AS SHOWN IN INSTALLATION DETAILS.
2. FOR ANCHORING INTO CONCRETE USE 3/16" TAPCON WITH SUFFICIENT LENGTH TO ACHIEVE A 1 3/4" MINIMUM EMBEDMENT WITH 1 1/4" MINIMUM EDGE DISTANCE. LOCATE ANCHORS AS SHOWN IN INSTALLATION DETAILS.
3. FOR ANCHORING INTO METAL STRUCTURE USE #10 SMS OR SELF DRILLING SCREWS WITH SUFFICIENT LENGTH TO ACHIEVE 3 THREADS MINIMUM BEYOND STRUCTURE INTERIOR WALL. LOCATE ANCHORS AS SHOWN IN INSTALLATION DETAILS.
4. FOR ATTACHING WINDOW UNITS TO MULLION USE #10 SELF DRILLING SCREWS WITH SUFFICIENT LENGTH TO ACHIEVE A MINIMUM EMBEDMENT OF THREE THREADS PAST THE MULLION WALL. LOCATE SCREWS IN ACCORDANCE WITH WINDOW ANCHORING SCHEDULE AS SHOWN IN WINDOW SEPARATE APPROVAL.
5. ALL FASTENERS TO BE CORROSION RESISTANT.
6. INSTALLATION ANCHORS SHALL BE INSTALLED IN ACCORDANCE WITH ANCHOR MANUFACTURER'S INSTALLATION INSTRUCTIONS, AND ANCHORS SHALL NOT BE USED IN SUBSTRATES WITH STRENGTHS LESS THAN THE MINIMUM STRENGTH SPECIFIED BELOW:
 - A. WOOD – MINIMUM SPECIFIC GRAVITY OF $G=0.42$
 - B. CONCRETE – MINIMUM COMPRESSIVE STRENGTH OF 3,200 PSI.
 - C. MASONRY – STRENGTH CONFORMANCE TO ASTM C-90, GRADE N, TYPE 1 (OR GREATER).
 - D. METAL STRUCTURE: STEEL 18GA, 33KSI OR ALUMINUM 6063-T5 .060" THICK MINIMUM
7. TO ATTACH MULLION TO CLIP USE (4) #10 x 1 1/4" SELF DRILLING SCREWS PER CLIP. SCREWS MUST BE FIELD INSTALLED.

SIGNED: 01/19/2018

TABLE OF CONTENTS	
SHEET NO.	DESCRIPTION
1	NOTES
2	APPROVED CONFIGURATIONS AND CHART
3 – 6	INSTALLATION DETAILS
7	COMPONENTS

		EASTERN ARCHITECTURAL SYSTEMS A DIVISION OF EASTERN METAL SUPPLY 16341 DOMESTIC AVE FORT MYERS, FL 33912 800-432-2204	
176 VERTICAL CROSS MULLION IMPACT – WIND ZONE 3 NOTES			
DRAWN: V.L.		DWG NO. 08-02426	
SCALE NTS		DATE 07/31/14	REV B
		SHEET 1 OF 7	
L. ROBERTO LOMAS P.E. 1432 WOODFORD RD LEWISVILLE, NC 27023 434-688-0609 rllomas@rlomaspe.com			

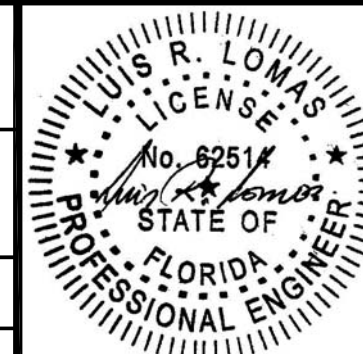

Luis R. Lomas P.E.
FL No.: 62514

REVISIONS			
REV	DESCRIPTION	DATE	APPROVED
A	REVISED INSTALLATION DETAILS	06/23/15	R.L.
B	REVISED PER NEW REQUIREMENTS	01/10/18	R.L.

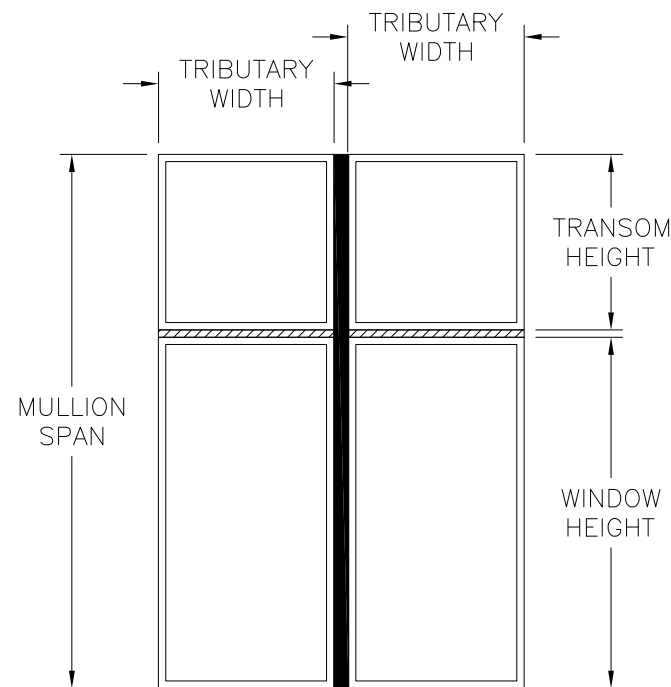

VERTICAL MULLION
 TWIN UNITS WITH TWIN TRANSOMS
 SEE CHARTS #1, #2, #3, & #4 FOR RATINGS

CHART #1

Design pressure chart (psf)									
Mullion span (in)	Window Height (in)	Transom Height (in)	Tributary width (in)						
			36.00	42.00	48.00	54.00	60.00	66.00	72.00
54.00	36.00	18.00	120.0	120.0	120.0	120.0	120.0	117.5	109.4
60.00	42.00	18.00	117.2	120.0	120.0	119.9	110.6	102.7	95.8
66.00	48.00	18.00	103.2	120.0	114.6	105.3	97.4	90.6	84.7
72.00	54.00	18.00	92.2	112.3	101.6	93.3	86.5	80.6	75.5
78.00	60.00	18.00	83.3	85.8	78.1	72.3	67.9	64.3	61.0
84.00	66.00	18.00	75.3	66.9	60.8	56.1	52.6	49.9	47.6
90.00	72.00	18.00	59.9	53.1	48.1	44.4	41.5	39.2	37.5
96.00	78.00	18.00	48.3	42.8	38.7	35.6	33.2	31.3	29.9
102.00	84.00	18.00	39.5	34.9	31.5	29.0	27.0	25.4	24.2

IMPACT RATED UP TO WIND ZONE 3

CHART #2

Design pressure chart (psf)									
Mullion span (in)	Window Height (in)	Transom Height (in)	Tributary width (in)						
			36.00	42.00	48.00	54.00	60.00	66.00	72.00
60.00	36.00	24.00	120.0	120.0	120.0	120.0	113.3	104.9	97.8
66.00	42.00	24.00	120.0	120.0	118.4	108.5	100.2	93.0	86.8
72.00	48.00	24.00	120.0	114.6	103.5	94.7	87.2	80.9	75.4
78.00	54.00	24.00	99.7	88.0	79.5	72.9	67.6	63.0	59.0
84.00	60.00	24.00	78.1	68.9	62.2	57.0	53.0	49.7	46.7
90.00	66.00	24.00	62.2	54.8	49.4	45.3	42.0	39.5	37.3
96.00	72.00	24.00	50.2	44.3	39.8	36.5	33.8	31.7	30.1
102.00	78.00	24.00	41.1	36.2	32.5	29.8	27.6	25.8	24.4
108.00	84.00	24.00	34.0	29.9	26.9	24.6	22.7	21.3	20.1

IMPACT RATED UP TO WIND ZONE 3

CHART #3

Design pressure chart (psf)									
Mullion span (in)	Window Height (in)	Transom Height (in)	Tributary width (in)						
			36.00	42.00	48.00	54.00	60.00	66.00	72.00
66.00	36.00	30.00	120.0	120.0	120.0	110.2	101.6	94.2	87.8
72.00	42.00	30.00	120.0	116.1	103.8	93.9	85.7	78.8	73.0
78.00	48.00	30.00	102.1	89.6	80.4	73.0	66.9	61.8	57.4
84.00	54.00	30.00	80.2	70.4	63.2	57.6	53.0	49.1	45.7
90.00	60.00	30.00	64.1	56.2	50.4	45.9	42.4	39.4	36.9
96.00	66.00	30.00	51.9	45.5	40.8	37.1	34.3	32.0	30.0
102.00	72.00	30.00	42.5	37.3	33.4	30.4	28.0	26.1	24.6
108.00	78.00	30.00	35.2	30.9	27.6	25.1	23.2	21.6	20.3
114.00	84.00	30.00	29.5	25.8	23.1	21.0	19.4	18.0	16.9

IMPACT RATED UP TO WIND ZONE 3

CHART #4

Design pressure chart (psf)									
Mullion span (in)	Window Height (in)	Transom Height (in)	Tributary width (in)						
			36.00	42.00	48.00	54.00	60.00	66.00	72.00
72.00	36.00	36.00	120.0	116.6	103.8	93.5	85.1	78.1	72.1
78.00	42.00	36.00	103.3	90.6	80.8	72.9	66.5	61.1	56.5
84.00	48.00	36.00	81.6	71.5	63.9	57.8	52.8	48.6	45.0
90.00	54.00	36.00	65.4	57.2	51.1	46.4	42.5	39.3	36.5
96.00	60.00	36.00	53.1	46.5	41.5	37.6	34.6	32.0	29.8
102.00	66.00	36.00	43.6	38.1	34.0	30.9	28.4	26.3	24.6
108.00	72.00	36.00	36.2	31.7	28.2	25.6	23.5	21.8	20.4
114.00	78.00	36.00	30.4	26.5	23.7	21.4	19.7	18.3	17.1
120.00	84.00	36.00	25.7	22.4	20.0	18.1	16.6	15.4	-

IMPACT RATED UP TO WIND ZONE 3

DESIGN PRESSURE TABLE INSTRUCTIONS:

1. DEFINE REQUIRED DESIGN LOAD PER FLORIDA BUILDING CODE CHAPTER 16.
2. DETERMINE TRIBUTARY WIDTH AND MULLION SPAN BASED ON PRODUCT TO BE INSTALLED. SEE FORMULA FOR TRIBUTARY WIDTH.
3. LOCATE MULLION SPAN (UNIT HEIGHT) AND TRIBUTARY WIDTH. AT THE INTERSECTION OF ROW AND COLUMN CONTAINING THE MULLION SPAN AND TRIBUTARY WIDTH RESPECTIVELY IS THE MULLION RATING FOR PRODUCT IN STEP 2. MULLION RATING MUST BE EQUAL OR GREATER THAN REQUIRED DESIGN PRESSURE OBTAINED IN STEP 1.

$$\text{TRIBUTARY WIDTH} = \frac{W1 + W2}{2}$$

SIGNED: 01/19/2018



Eastern
ARCHITECTURAL SYSTEMS
ALUMINUM AND VINYL
IMPACT WINDOWS AND DOORS

EASTERN ARCHITECTURAL SYSTEMS
 A DIVISION OF
 EASTERN METAL SUPPLY
 16341 DOMESTIC AVE
 FORT MYERS, FL 33912
 800-432-2204

176 VERTICAL CROSS MULLION
 IMPACT - WIND ZONE 3
 APPROVED CONFIGURATIONS AND CHARTS

DRAWN: V.L.	DWG NO. 08-02426	REV B
SCALE NTS	DATE 07/31/14	SHEET 2 OF 7

L. ROBERTO LOMAS P.E.
 1432 WOODFORD RD LEWISVILLE, NC 27023
 434-688-0609 rllomas@rlomaspe.com

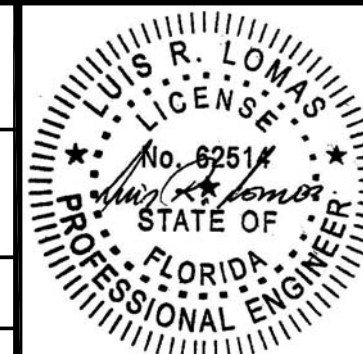

Luis R. Lomas P.E.
 FL No.: 62514

REVISIONS			
REV	DESCRIPTION	DATE	APPROVED
A	REVISED INSTALLATION DETAILS	06/23/15	R.L.
B	REVISED PER NEW REQUIREMENTS	01/10/18	R.L.

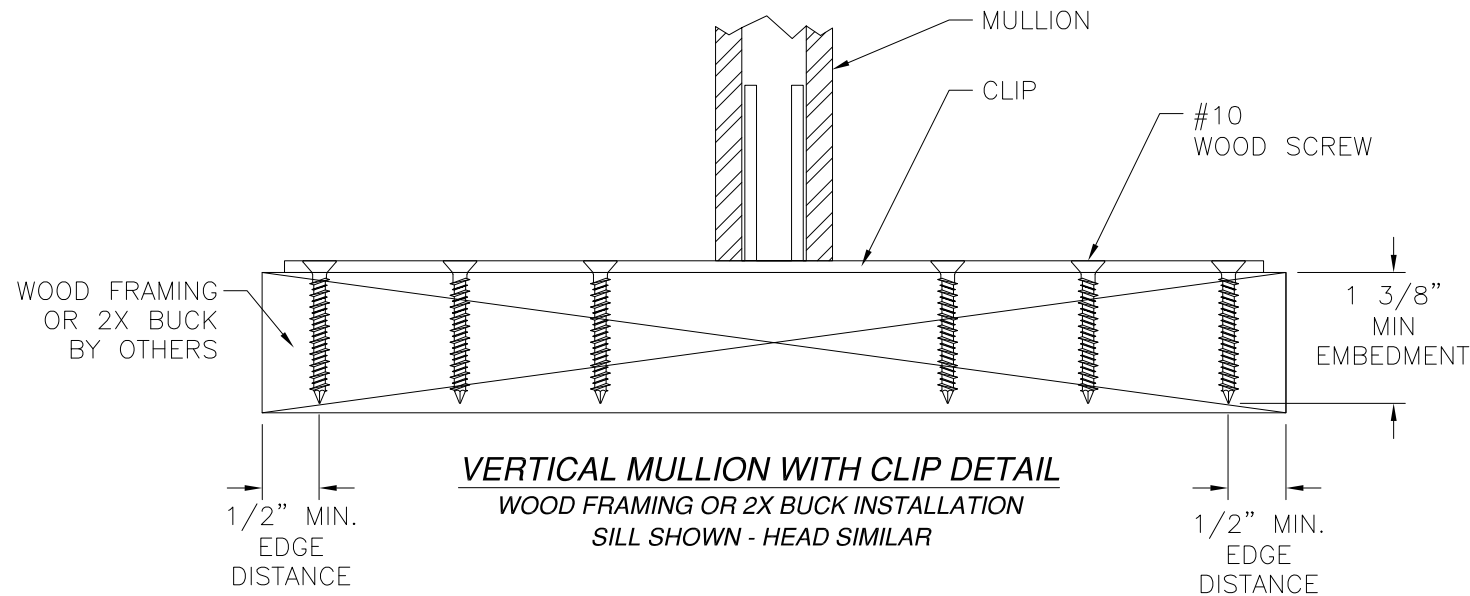
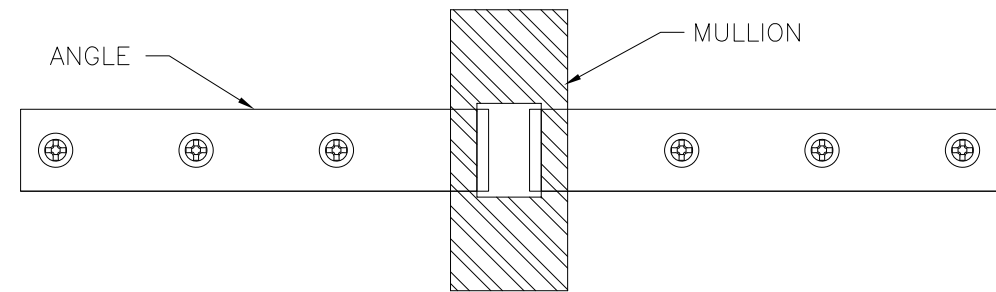
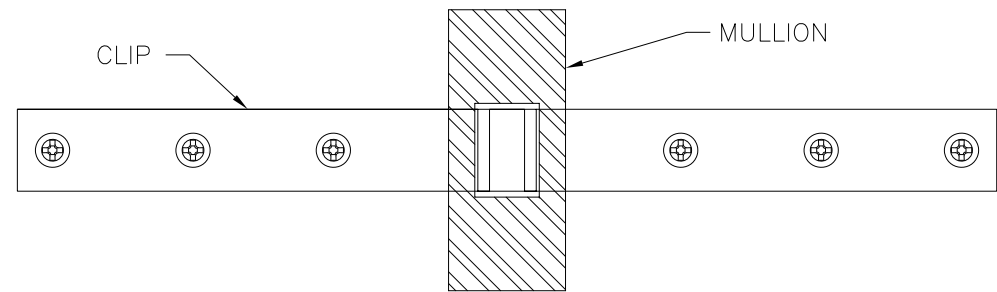

VERTICAL MULLION WITH CLIP DETAIL
WOOD FRAMING OR 2X BUCK INSTALLATION
SILL SHOWN - HEAD SIMILAR

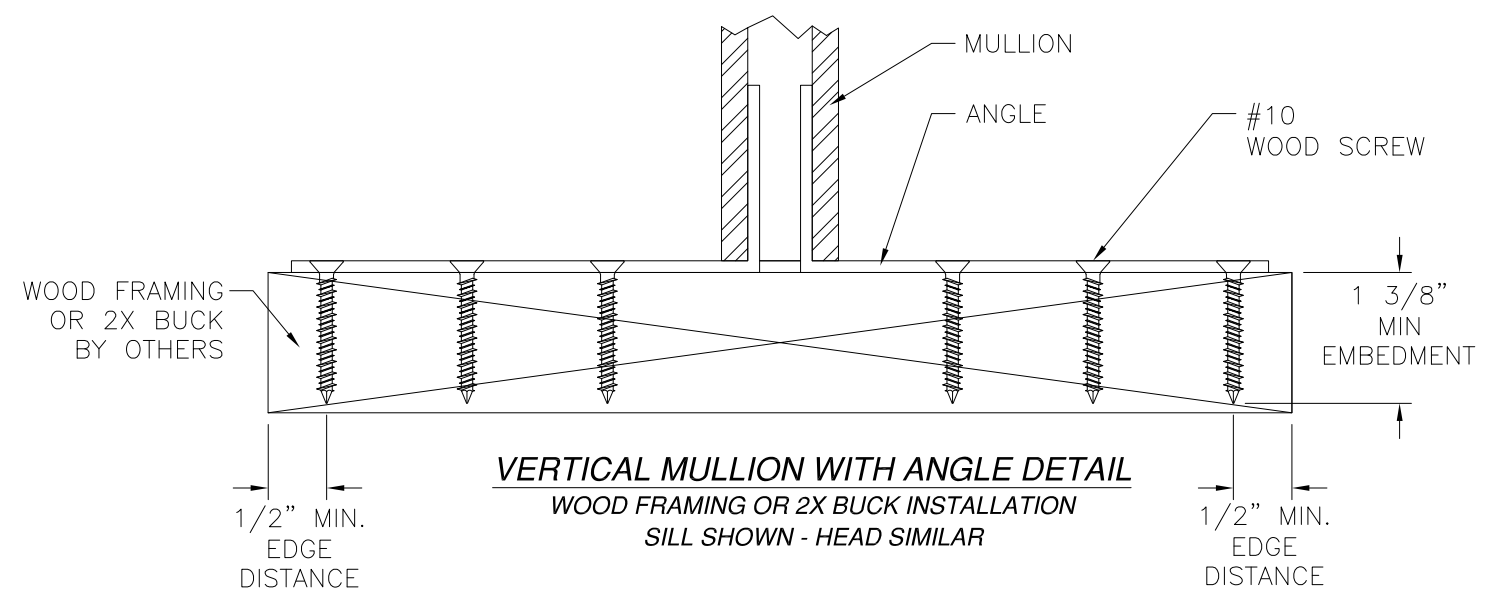

VERTICAL MULLION WITH ANGLE DETAIL
WOOD FRAMING OR 2X BUCK INSTALLATION
SILL SHOWN - HEAD SIMILAR

SIGNED: 01/19/2018



Eastern
ARCHITECTURAL SYSTEMS
ALUMINUM AND VINYL
IMPACT WINDOWS AND DOORS

EASTERN ARCHITECTURAL SYSTEMS
A DIVISION OF
EASTERN METAL SUPPLY
16341 DOMESTIC AVE
FORT MYERS, FL 33912
800-432-2204

176 VERTICAL CROSS MULLION
IMPACT - WIND ZONE 3
INSTALLATION DETAILS

DRAWN: V.L.	DWG NO. 08-02426	REV B
SCALE NTS	DATE 07/31/14	SHEET 3 OF 7

L. ROBERTO LOMAS P.E.
1432 WOODFORD RD LEWISVILLE, NC 27023
434-688-0609 rllomas@rlomaspe.com

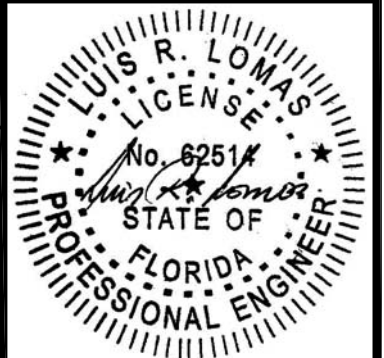

Luis R. Lomas P.E.
FL No.: 62514

REVISIONS			
REV	DESCRIPTION	DATE	APPROVED
A	REVISED INSTALLATION DETAILS	06/23/15	R.L.
B	REVISED PER NEW REQUIREMENTS	01/10/18	R.L.

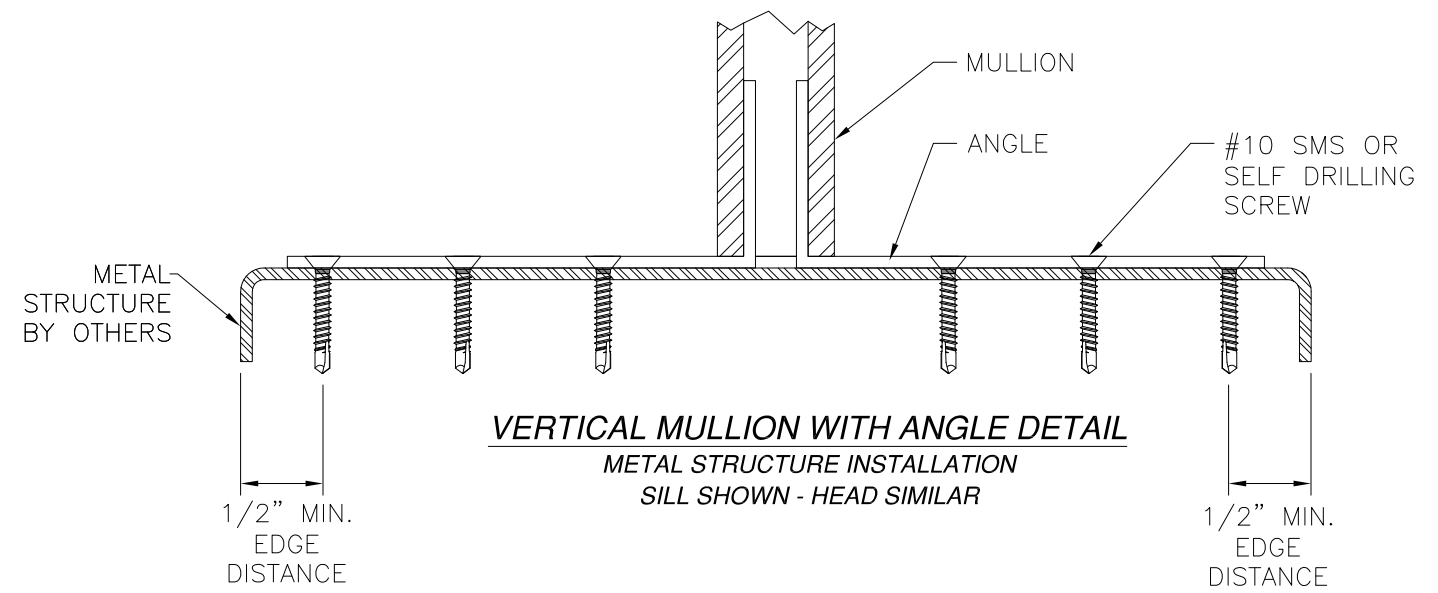
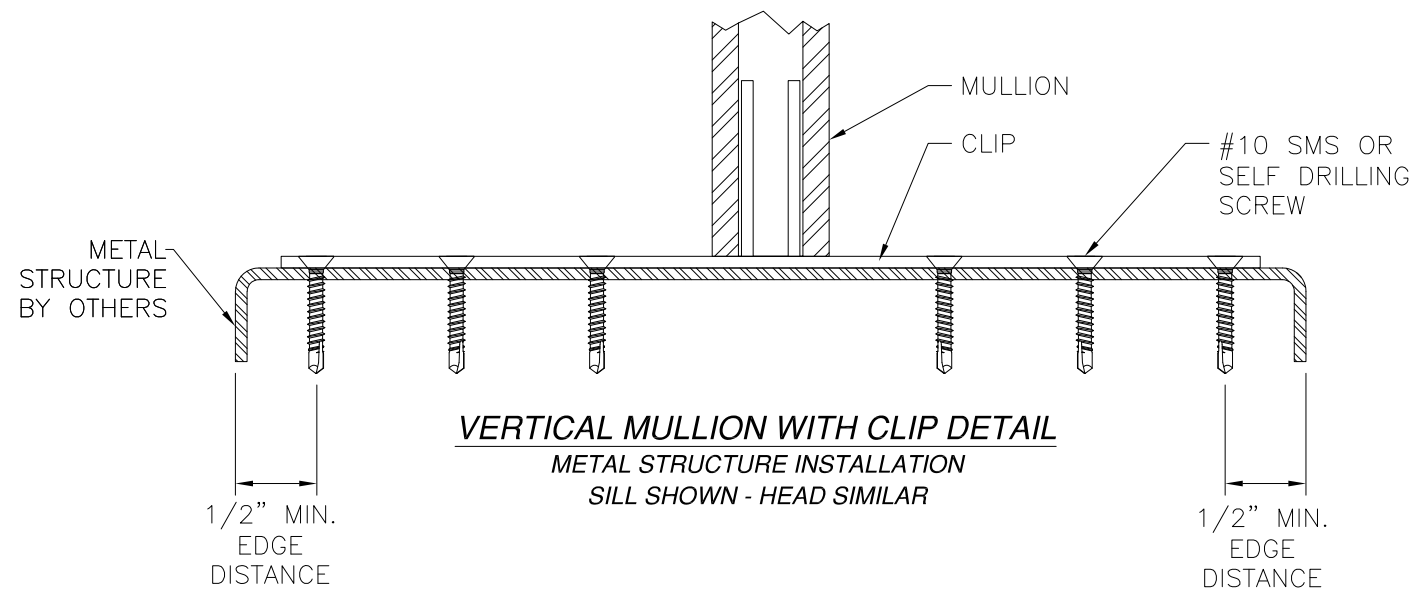
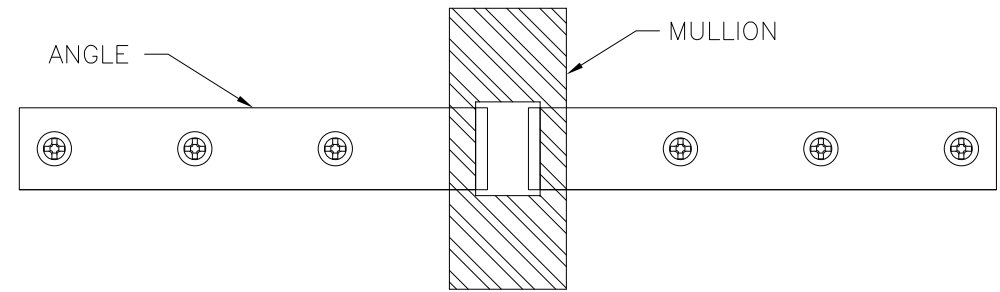
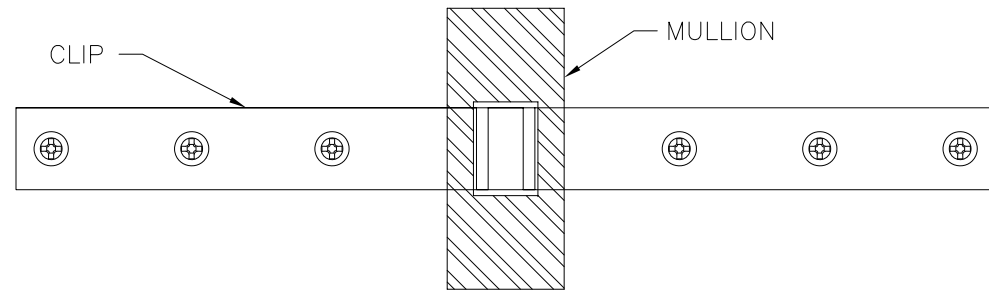

VERTICAL MULLION WITH CLIP DETAIL
METAL STRUCTURE INSTALLATION
SILL SHOWN - HEAD SIMILAR

VERTICAL MULLION WITH ANGLE DETAIL
METAL STRUCTURE INSTALLATION
SILL SHOWN - HEAD SIMILAR

SIGNED: 01/19/2018



Eastern
ARCHITECTURAL SYSTEMS
ALUMINUM AND VINYL
IMPACT WINDOWS AND DOORS

EASTERN ARCHITECTURAL SYSTEMS
A DIVISION OF
EASTERN METAL SUPPLY
16341 DOMESTIC AVE
FORT MYERS, FL 33912
800-432-2204

176 VERTICAL CROSS MULLION
IMPACT - WIND ZONE 3
INSTALLATION DETAILS

DRAWN: V.L.	DWG NO. 08-02426	REV B
SCALE NTS	DATE 07/31/14	SHEET 4 OF 7

L. ROBERTO LOMAS P.E.
1432 WOODFORD RD LEWISVILLE, NC 27023
434-688-0609 rllomas@rlomaspe.com

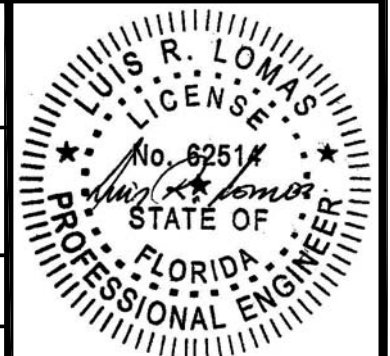

Luis R. Lomas P.E.
FL No.: 62514

REVISIONS			
REV	DESCRIPTION	DATE	APPROVED
A	REVISED INSTALLATION DETAILS	06/23/15	R.L.
B	REVISED PER NEW REQUIREMENTS	01/10/18	R.L.

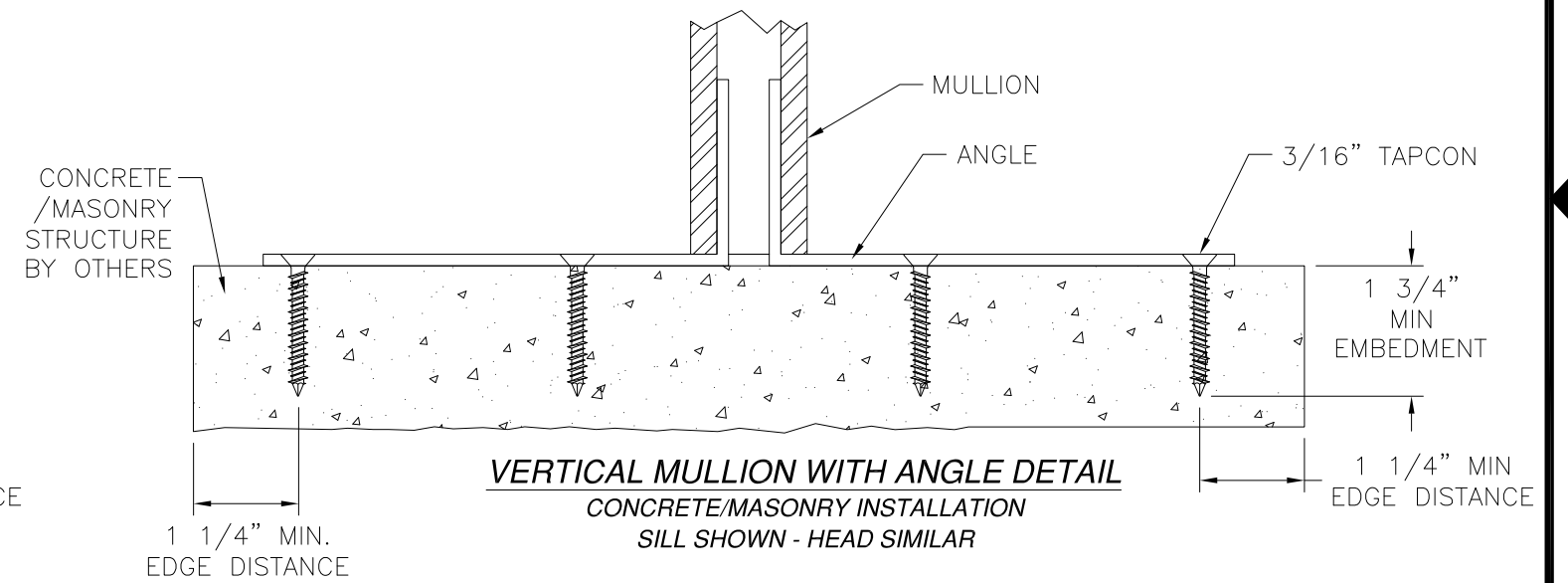
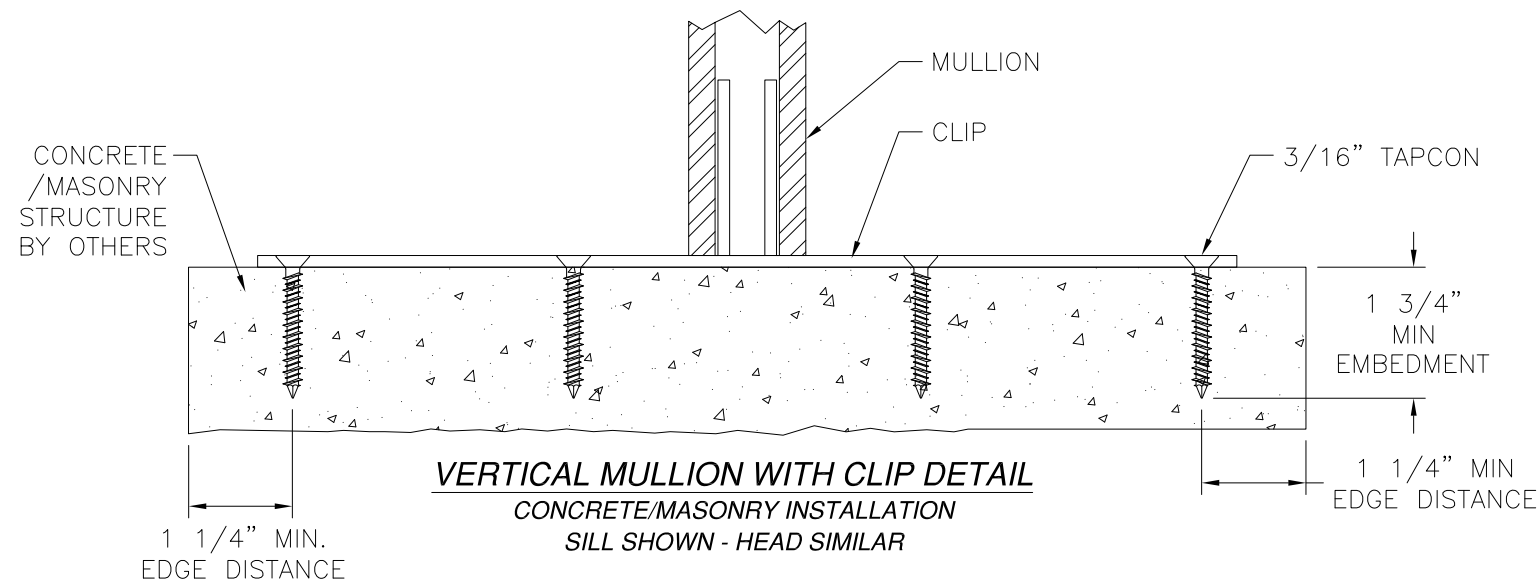
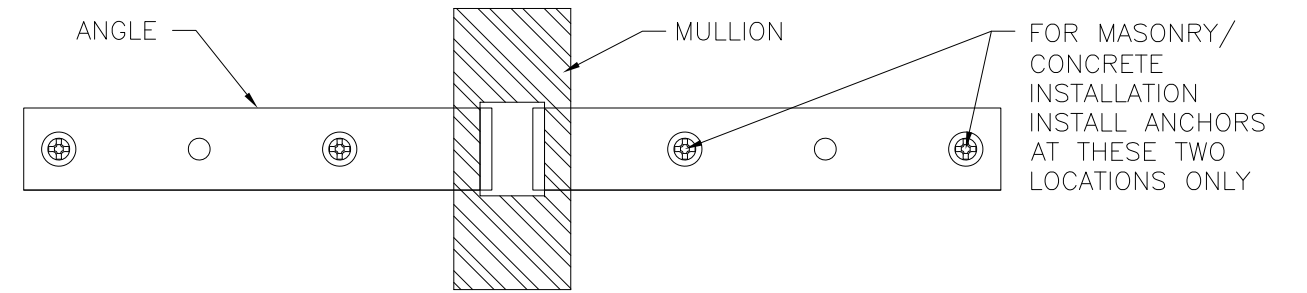
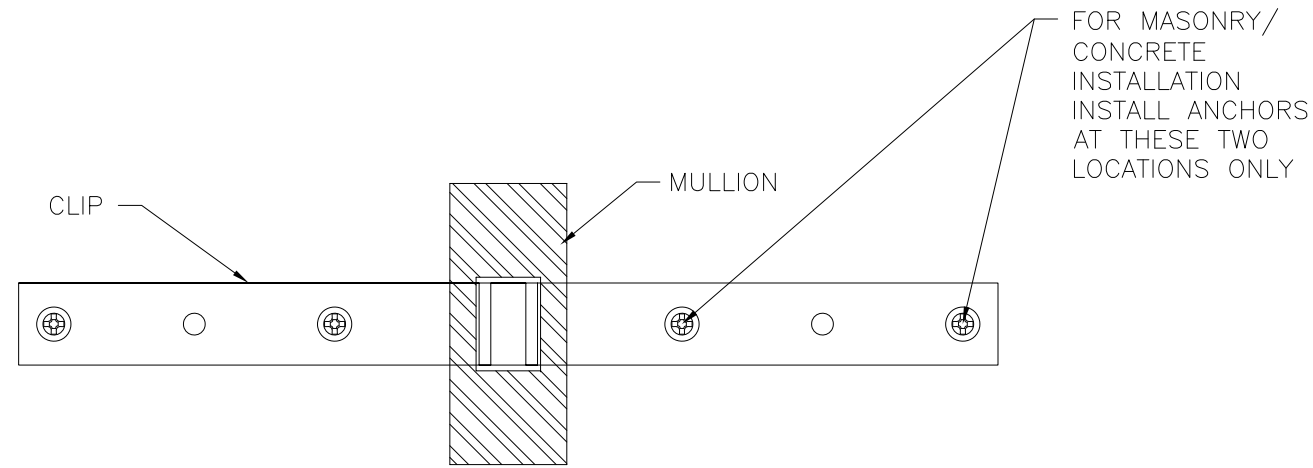

SIGNED: 01/19/2018

 Eastern ARCHITECTURAL SYSTEMS ALUMINUM AND VINYL IMPACT WINDOWS AND DOORS		EASTERN ARCHITECTURAL SYSTEMS A DIVISION OF EASTERN METAL SUPPLY 16341 DOMESTIC AVE FORT MYERS, FL 33912 800-432-2204	
176 VERTICAL CROSS MULLION IMPACT - WIND ZONE 3 INSTALLATION DETAILS			
DRAWN: V.L.	DWG NO. 08-02426	REV B	
SCALE NTS	DATE 07/31/14	SHEET 5 OF 7	
L. ROBERTO LOMAS P.E. 1432 WOODFORD RD LEWISVILLE, NC 27023 434-688-0609 rllomas@lrlomaspe.com			

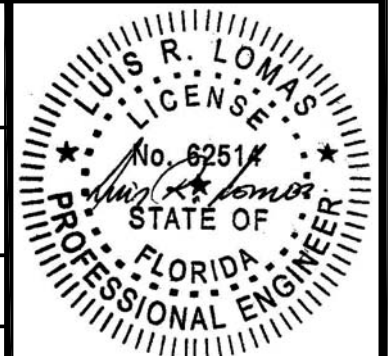

Luis R. Lomas P.E.
FL No.: 62514

REVISIONS			
REV	DESCRIPTION	DATE	APPROVED
A	REVISED INSTALLATION DETAILS	06/23/15	R.L.
B	REVISED PER NEW REQUIREMENTS	01/10/18	R.L.

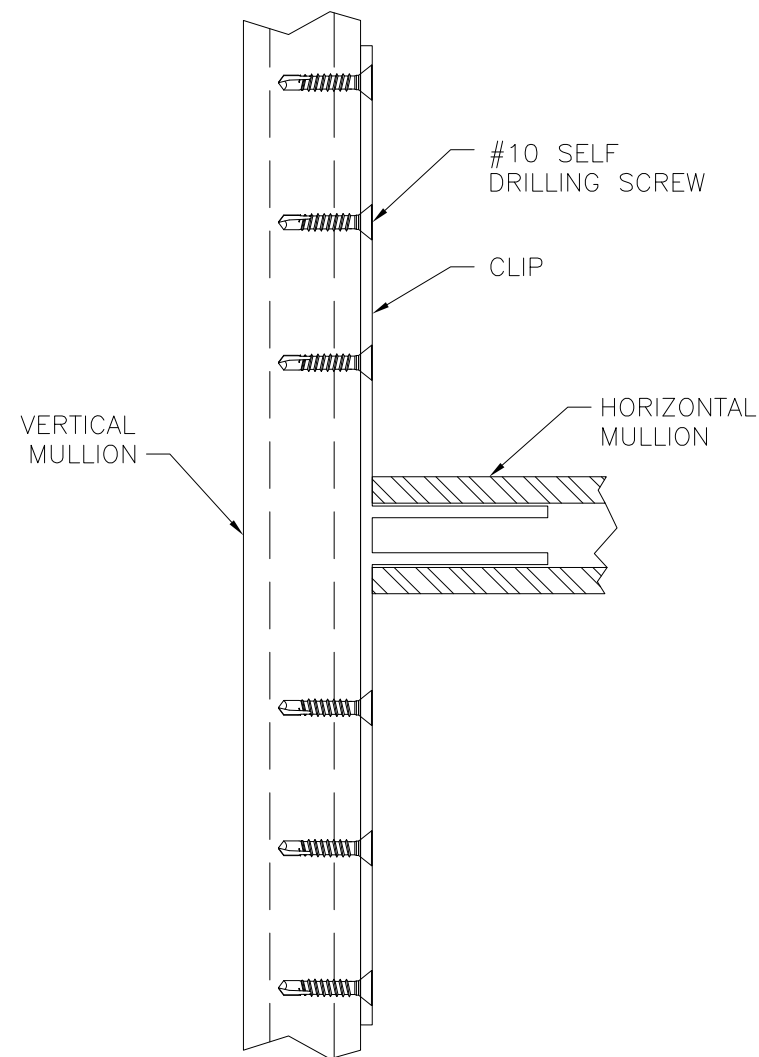
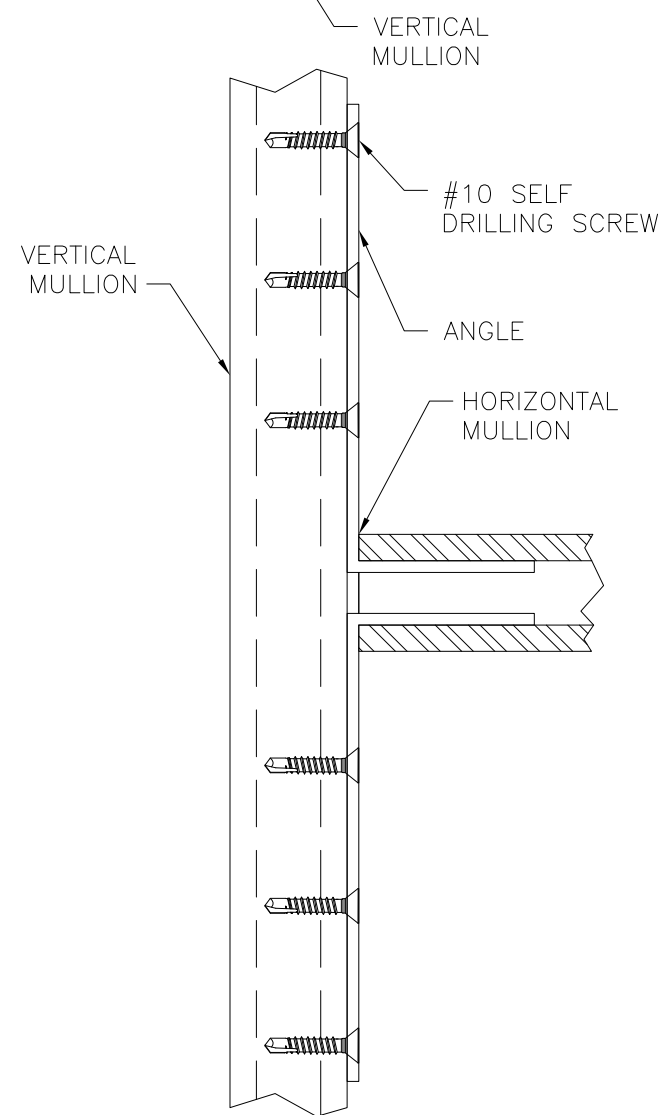
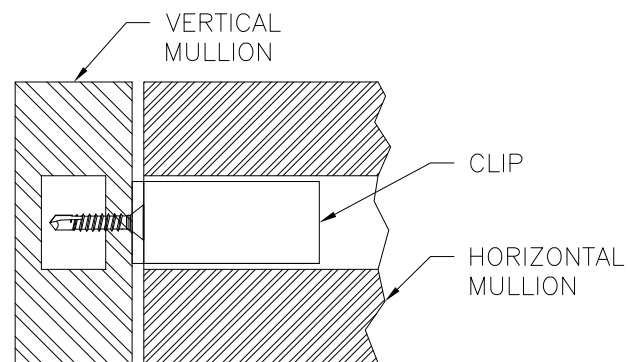
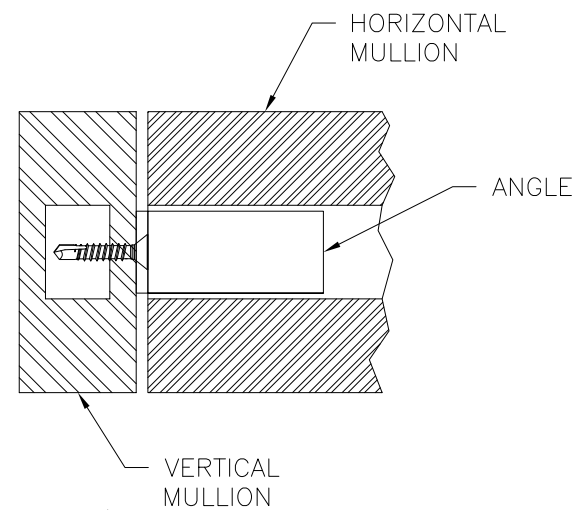

VERTICAL TO HORIZONTAL MULLION CONNECTION WITH ANGLE

VERTICAL TO HORIZONTAL MULLION CONNECTION WITH CLIP

Eastern ARCHITECTURAL SYSTEMS
 A DIVISION OF EASTERN METAL SUPPLY
 16341 DOMESTIC AVE
 FORT MYERS, FL 33912
 800-432-2204

176 VERTICAL CROSS MULLION
 IMPACT - WIND ZONE 3
 INSTALLATION DETAILS

DRAWN: V.L.	DWG NO. 08-02426	REV B
SCALE NTS	DATE 07/31/14	SHEET 6 OF 7

L. ROBERTO LOMAS P.E.
 1432 WOODFORD RD LEWISVILLE, NC 27023
 434-688-0609 rllomas@lrlomaspe.com

SIGNED: 01/19/2018

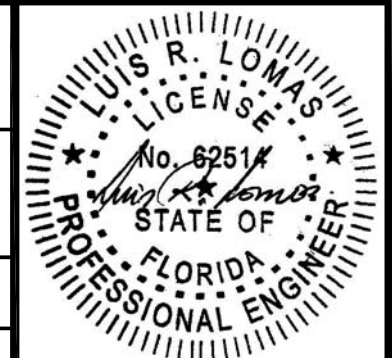

Luis R. Lomas P.E.
 FL No.: 62514

REVISIONS			
REV	DESCRIPTION	DATE	APPROVED
A	REVISED INSTALLATION DETAILS	06/23/15	R.L.
B	REVISED PER NEW REQUIREMENTS	01/10/18	R.L.

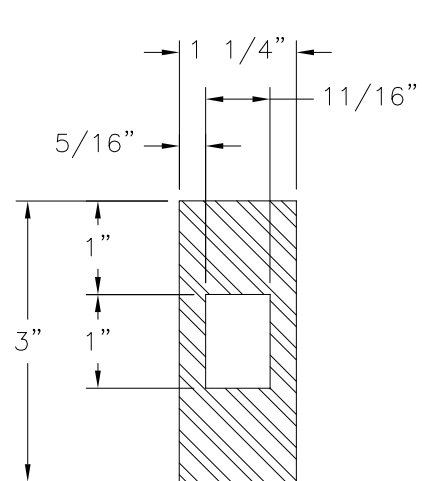

1 1/4"X3" TUBE MULLION
 ALUMINUM 6063-T6 .125" THICK
 MOMENT OF INERTIA: 2.755 IN⁴
 SECTION MODULUS: 1.864 IN³

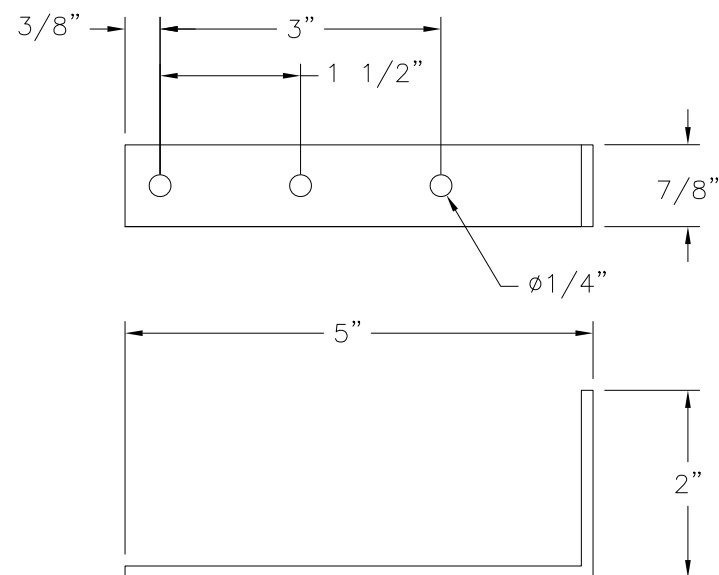

ANGLE
 ALUMINUM 6063-T6 .125" THICK

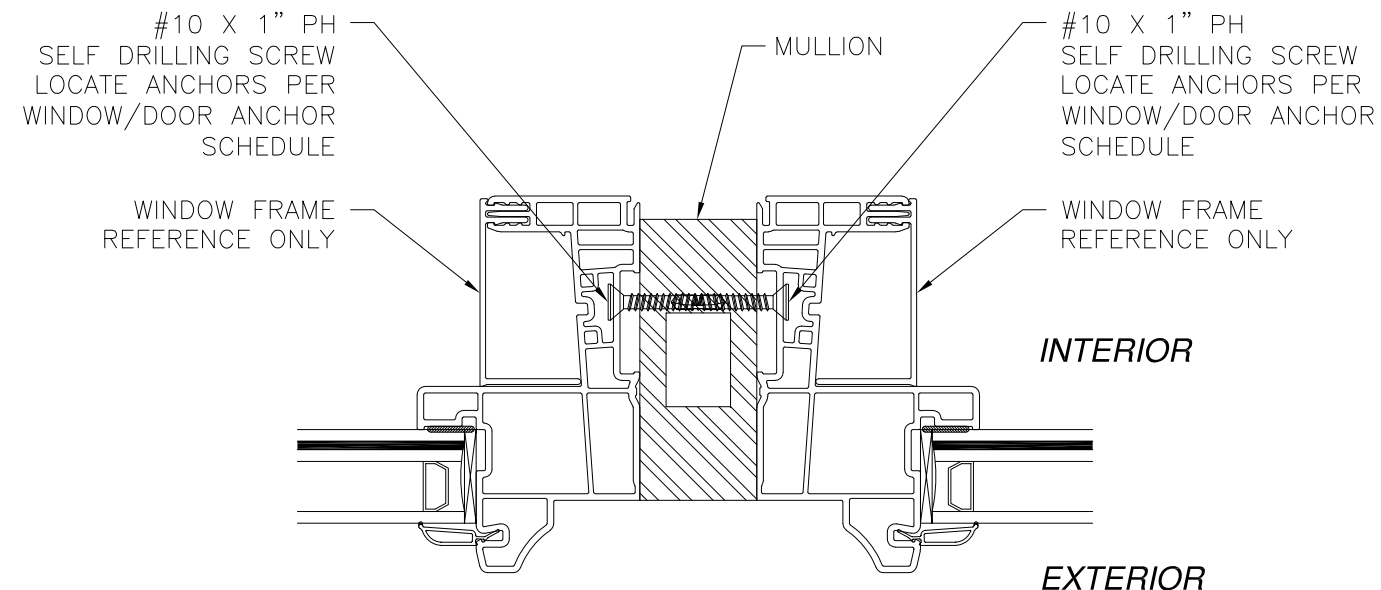

WINDOW TO MULLION INSTALLATION DETAIL
 WINDOW FRAME SHOWN FOR DETAIL PURPOSES ONLY
 MULLION IS NOT LIMITED TO THIS PRODUCT

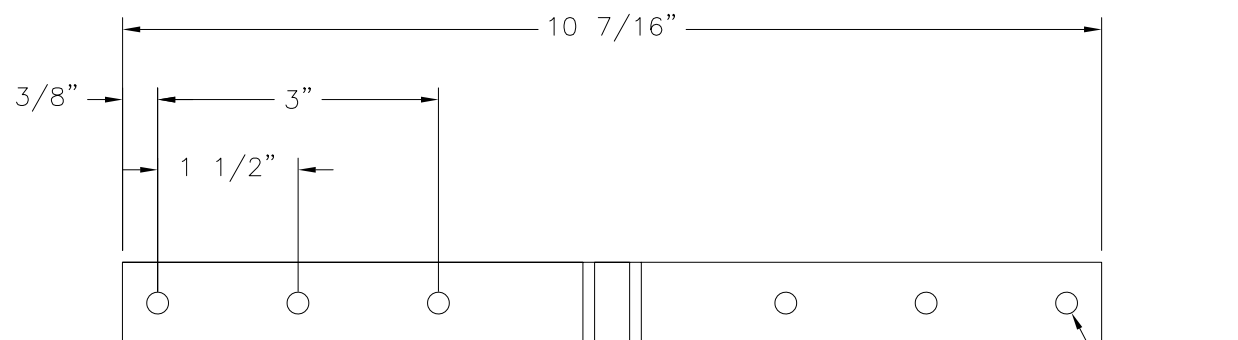

CLIP
 ALUMINUM 6063-T6 .125" THICK

SIGNED: 01/19/2018

		EASTERN ARCHITECTURAL SYSTEMS A DIVISION OF EASTERN METAL SUPPLY 16341 DOMESTIC AVE FORT MYERS, FL 33912 800-432-2204	
176 VERTICAL CROSS MULLION IMPACT - WIND ZONE 3 COMPONENTS			
DRAWN: V.L.	DWG NO. 08-02426	REV B	
SCALE NTS	DATE 07/31/14	SHEET 7 OF 7	
L. ROBERTO LOMAS P.E. 1432 WOODFORD RD LEWISVILLE, NC 27023 434-688-0609 rllomas@lrlomaspe.com			

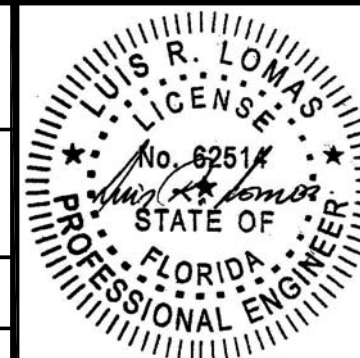

Luis R. Lomas P.E.
 FL No.: 62514