

HURRICANE STORM PANEL MANUFACTURING

HVHZ IMPACT STORM PANEL

INSTALLATION ANCHORAGE DETAILS

GENERAL NOTES:

- THIS PRODUCT HAS BEEN TESTED AND IS DESIGNED TO COMPLY WITH THE OPENING PROTECTION REQUIREMENTS OF THE CURRENT EDITION OF THE FLORIDA BUILDING CODE - BUILDING AND RESIDENTIAL VOLUMES INCLUDING THE HIGH VELOCITY HURRICANE ZONE (HVHZ - LMI) AND WIND BORNE DEBRIS AREA (WIND ZONE 4, MISSILE LEVEL D).
 - THE PRODUCT DETAILS CONTAINED HEREIN ARE BASED UPON SIGNED AND SEALED TEST REPORT # ATLNC 0428.01-04 AND ATLNC 0428.03-04 DATED 05/28/04, AND ATLNC 0224.01-09 AND ATLNC 0224.02-09 DATED 02/25/09 AND ASSOCIATED LABORATORY STAMPED DRAWINGS.
- ADEQUACY OF THE EXISTING STRUCTURAL CONCRETE / MASONRY AND 2X FRAMING AS A MAIN WIND FORCE RESISTING SYSTEM CAPABLE OF WITHSTANDING AND TRANSFERRING APPLIED PRODUCT LOADS TO THE STRUCTURE IS THE RESPONSIBILITY OF THE ENGINEER OR ARCHITECT OF RECORD.
- PANEL MATERIAL: 0.050 3105-H14 ALUMINUM ALLOY OR 24 GA. (0.023" MIN.) STEEL WITH Fy = 53 KSI AFTER ROLLING, CONFORMING TO ASTM A-446 STRUCTURAL QUALITY STEEL, GRADE C MIN. WITH A G60 MIN. COATING OF GALVANIZED STEEL.
- ALL BOLTS AND WASHERS SHALL BE GALVANIZED OR STAINLESS STEEL WITH A MINIMUM TENSILE STRENGTH OF 60 K.S.I.
- AT LEAST ONE WARNING NOTE PER OPENING MAY BE PLACED IN A CONSPICUOUS LOCATION ON THE PANEL SYSTEM ADVISING THE HOMEOWNER OR TENANT THAT THE PANELS WILL NOT OFFER HURRICANE PROTECTION UNLESS ALL PANELS AND FASTENERS ARE INSTALLED AS SHOWN HEREIN AND WARN INSTALLER IN THE SAME MANNER THAT HANDLING PANEL WITHOUT PROTECTIVE GLOVES COULD CAUSE INJURY.
- THE IMPACT PROTECTIVE SYSTEM SHALL BE INSTALLED IN A MANNER TO COMPLETELY COVER THE ENTIRE FENESTRATION (WALL OPENING) IN ALL DIRECTIONS.
- WHEN INSTALLED AS INDICATED, THE PRODUCT HEREIN IS CONSIDERED A NON-POROUS IMPACT PROTECTIVE SYSTEM.
 - WHEN USED OUTSIDE THE HIGH VELOCITY HURRICANE ZONE (HVHZ), NO MINIMUM SEPARATION FROM THE PROTECTED FENESTRATION ASSEMBLY IS REQUIRED. HOWEVER, THE MANUFACTURER SUGGESTS A MINIMUM SEPARATION OF 1 INCH., THE SEPARATION TABLE SHOWN ON SHEET 6 CAN BE USED TO PROVIDE A SEPARATION DISTANCE IF DESIRED BY THE USER.
 - WHEN INSTALLED IN THE HIGH VELOCITY HURRICANE ZONE (HVHZ), A MINIMUM SEPARATION DISTANCE AS SHOWN IN THE SEPARATION TABLE ON SHEET 6 MEETING THE REQUIREMENTS OF CHAPTER 24 OF THE CURRENT EDITION OF THE FLORIDA BUILDING CODE SHALL BE MAINTAINED.
- THE PRODUCT DESCRIBED HEREIN IS DESIGNED FOR USE AS A IMPACT RESISTANT COVERING DURING PERIODS OF HIGH WINDS. THE STORM PANEL IS TEMPORARY AND REMOVABLE AND NOT INTENDED TO BE A PERMANENT PART OF THE STRUCTURE (ALTHOUGH THE INSTALLATION ANCHORS SHALL REMAIN A PERMANENT PART OF THE STRUCTURE).
- MAXIMUM PANEL SIZE: SEE CHARTS ON SHEET 6.
- PANELS MAY BE MOUNTED HORIZONTALLY WHERE APPLICABLE.
- THE DRAWING SECTIONS HEREIN DEPICT TYPICAL CONCRETE / MASONRY AND WOOD INSTALLATION ANCHORAGE CONNECTIONS. THESE DETAILS MAY BE USED INTERCHANGEABLY AS FIELD CONDITIONS DICTATE.
- A PERMANENT LABEL IN ACCORDANCE WITH CHAPTER 17 OF THE CURRENT EDITION OF THE FBC AND CHAPTER 6 OF THE CURRENT EDITION OF THE FRC SHALL BE PLACED ON THE IMPACT RESISTANT COVERINGS AND SHALL FACE THE EXTERIOR OR OUTSIDE.

TABLE OF CONTENTS		
SHEET	REV.	SHEET DESCRIPTION
1	-	GENERAL & INSTALLATION NOTES & ELEVATION
2	-	VERTICAL SECTIONS
3	-	VERTICAL SECTIONS
4	-	VERTICAL & HORIZONTAL SECTIONS
5	-	COMPONENTS
6	-	PANEL DP SCHEDULE & SEPARATION SCHEDULE
7	-	ANCHOR SCHEDULE & EGRESS SHUTTER ASSEMBLY

DESIGN PRESSURE RATING (PSF)
SEE CHARTS ON SHEET 6

INSTALLATION NOTES:

- SEE ANCHOR SCHEDULE ON SHEET 7 OF 7 FOR ALLOWED FASTENERS, MINIMUM EMBEDMENT, MINIMUM EDGE DISTANCE AND REQUIRED ON CENTER (O.C.) ANCHOR SPACING.
- INSTALLATION ANCHORS SHALL BE 3 INCHES FROM TRACK EDGE, 12 INCHES OR 8 INCHES MAXIMUM ON CENTER AS REQUIRED BY THE ANCHOR SCHEDULE ON SHEET 7 OF 7.
- MINIMUM EDGE DISTANCE AND EMBEDMENT EXCLUDE WALL FINISHES (INCLUDING BUT NOT LIMITED TO STUCCO, FOAM, BRICK VENEER AND SIDING).
- FOR CONCRETE BLOCK APPLICATIONS, DO NOT INSTALL INSTALLATION ANCHORS INTO MORTAR JOINTS.
- INSTALLATION ANCHORS SHALL BE INSTALLED IN ACCORDANCE WITH ANCHOR MANUFACTURER'S INSTALLATION INSTRUCTIONS AND ANCHORS SHALL NOT BE USED IN SUBSTRATES WITH STRENGTHS LESS THAN THE MINIMUM STRENGTH SPECIFIED BY THE ANCHOR MANUFACTURER.
- INSTALLATION ANCHOR COMPACITIES FOR PRODUCTS HEREIN ARE BASED ON SUBSTRATE MATERIALS WITH THE FOLLOWING PROPERTIES:
 - WOOD - MINIMUM SPECIFIC GRAVITY IS 0.42.
 - CONCRETE - MINIMUM COMPRESSIVE STRENGTH SHALL BE AS SHOWN IN ANCHOR SCHEDULE ON SHEET 7.
 - MASONRY - STRENGTH COMFORMANCE TO ASTM C-90.
- STORM SHUTTER END CLOSURE:
 - NON-HIGH VELOCITY HURRICANE ZONE (HVHZ) INSTALLATIONS.
 - END CLOSURE IS OPTIONAL.
 - HIGH VELOCITY HURRICANE ZONE (HVHZ) INSTALLATIONS.
 - STORM SHUTTERS MUST COMPLETELY COVER AN OPENING IN ALL DIRECTIONS.
 - ON ANY SIDE OF AN OPENING, THE MAXIMUM SIDE CLEARANCE BETWEEN THE SHUTTER AND A WALL OR INSET SURFACE SHALL BE 1/4 INCH. ANY DISTANCE IN EXCESS OF 1/4 INCH SHALL REQUIRE END CLOSURE OR SHUTTER OVERLAP, WHERE APPLICABLE.
 - SHUTTER OVERLAP SHALL BE A MINIMUM OF 1.5 TIMES THE SIDE CLEARANCE BETWEEN THE SHUTTER AND WALL.

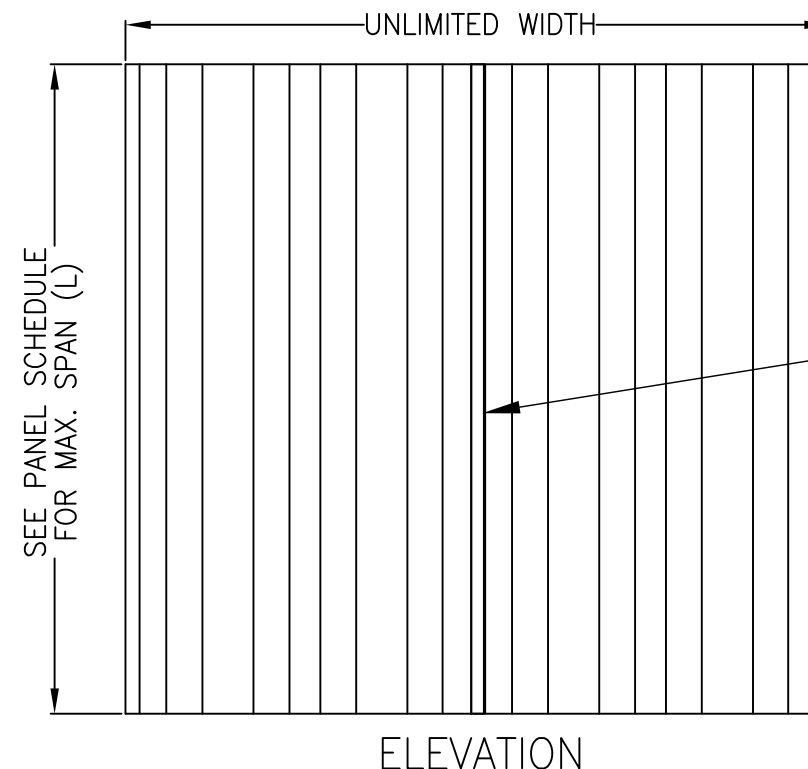

ONE FASTENER REQUIRED AT APPROXIMATE MID-POINT OF LAP JOINT, SEE PANEL LAP DETAIL ON SHEET 3 (APPLICABLE LENGTHS AS FOLLOWS: 24 GA. STEEL GREATER THAN 114" AND 0.050" ALUMINUM GREATER THAN 120"

PROJECT NO. 415-0109				
			04/30/15	JBH
	UPDATE TO 5TH EDITION (2014) FBC			
	CORRECT FASTENER SPACING ERROR		8/14/13	RJA
				DATE
				BY
	B	A	REV	

HURRICANE STORM PANEL MFG. INC.
1720 MAIN ST. NE, UNIT 1
PALM BAY, FL 32905

HVHZ IMPACT STORM PANEL
GENERAL, INSTALLATION NOTES & ELEVATION

DATE: 05/30/13
DRAWING NO: HSPM0001
SHEET: 1 OF 7

DRAWN BY: RJA
SCALE: N.T.S.
REV: B

PREPARED BY: **PTC**

Robert J. Amoroso
Florida P.E. No. 49752



PTC Product Design Group, LLC
P.O. Box 520775
Longwood, FL 32752-0775
FBPE Cert. of Authorization NO. 25935

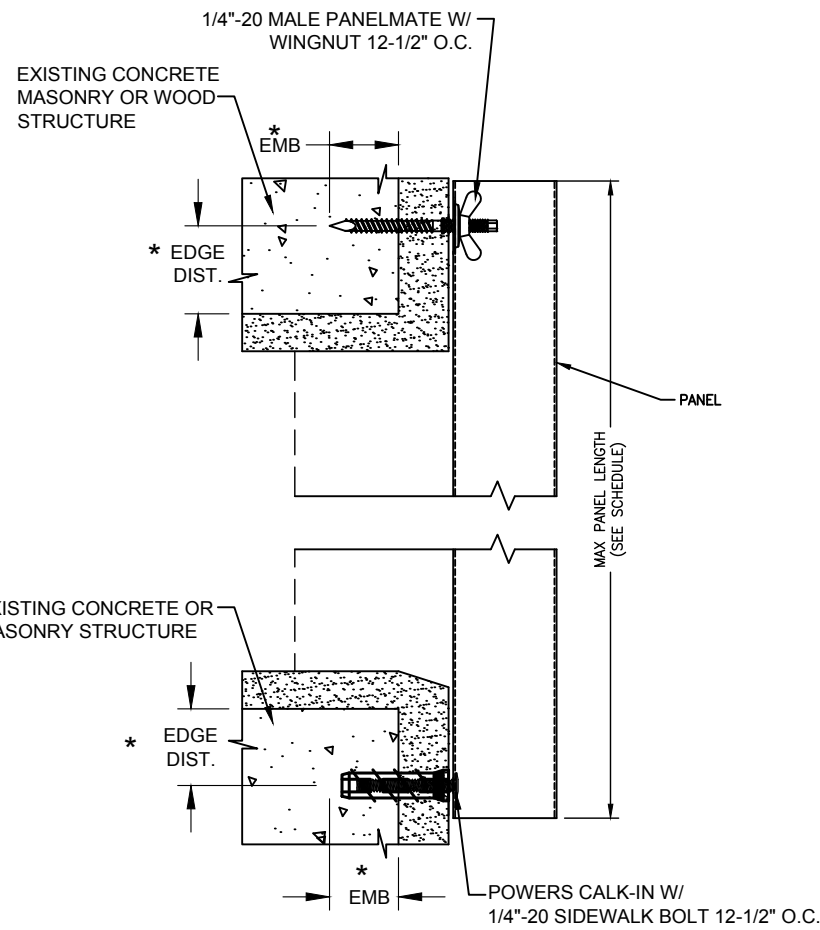

VERTICAL SECTION
DIRECT MOUNT

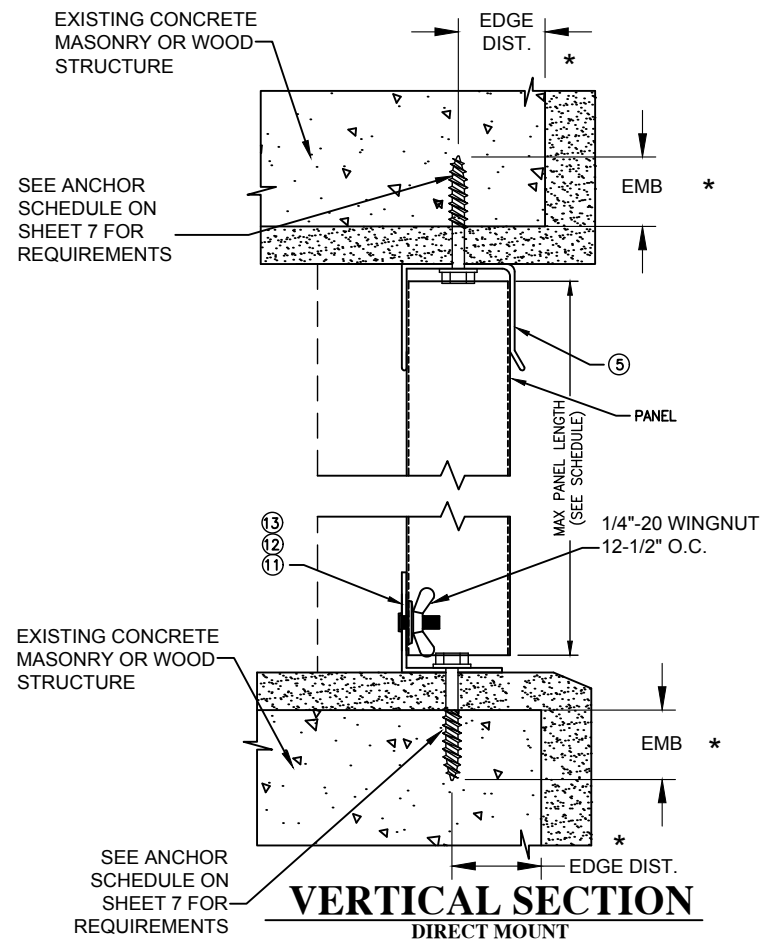

VERTICAL SECTION
DIRECT MOUNT

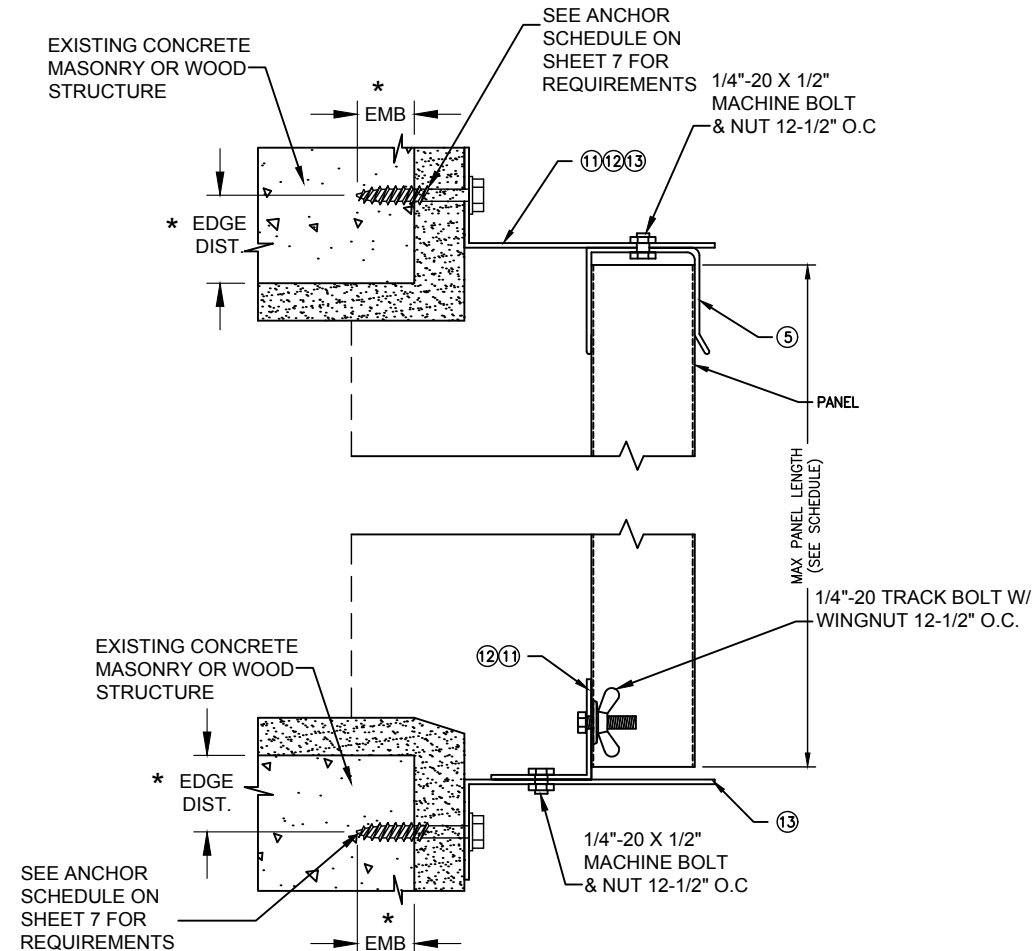

VERTICAL SECTION
BUILD-OUT MOUNT

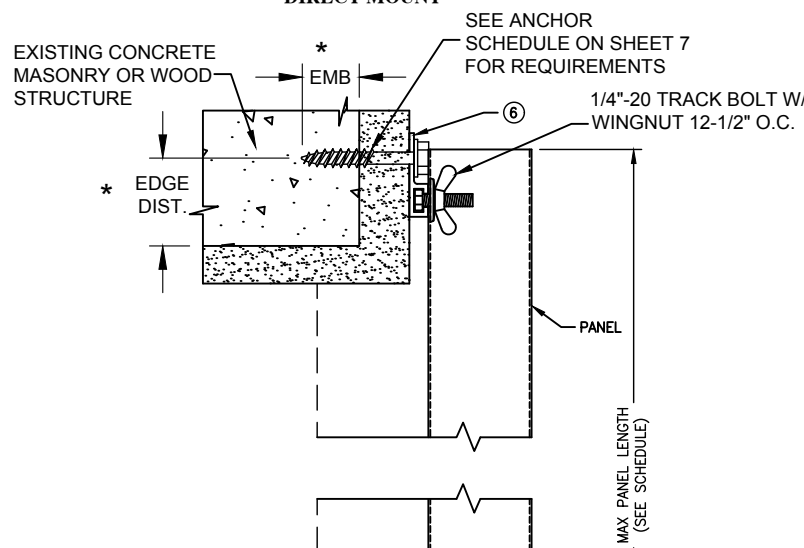

VERTICAL SECTION
DIRECT MOUNT

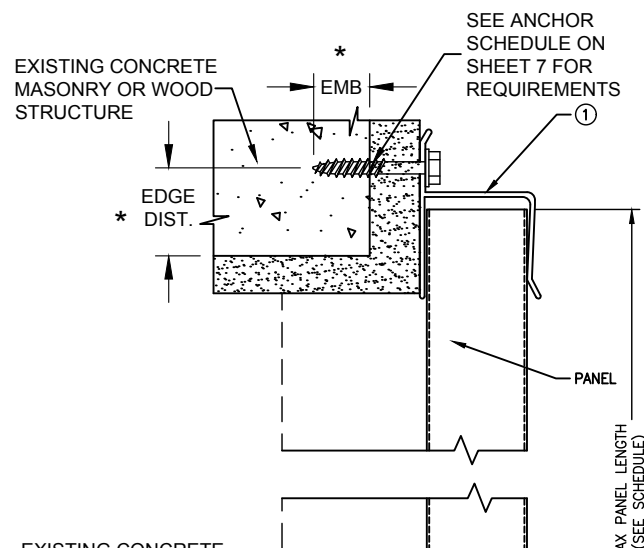

VERTICAL SECTION
DIRECT MOUNT

* SEE ANCHOR SCHEDULE SHEET 7

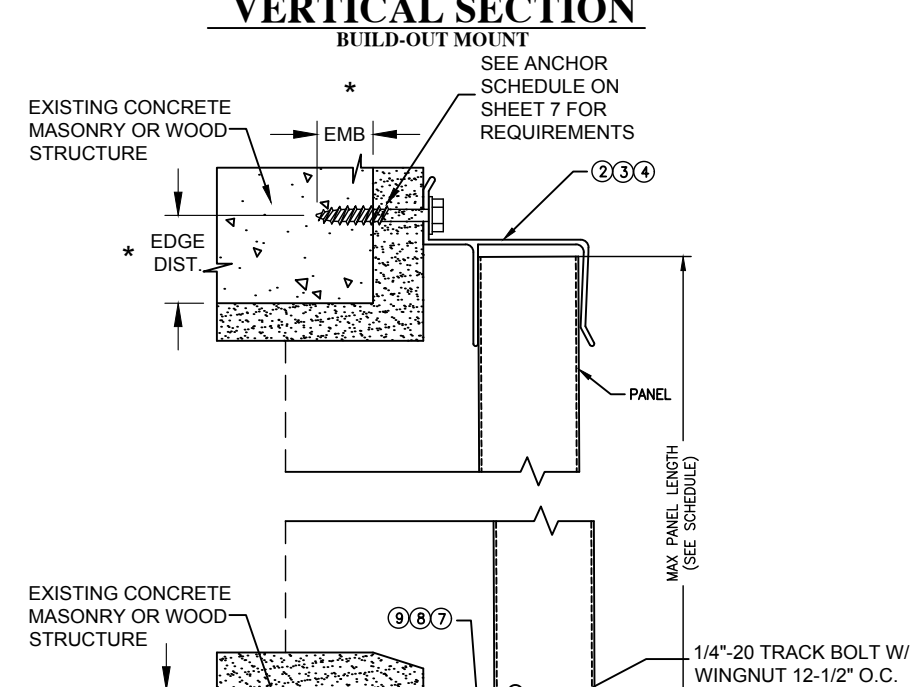

VERTICAL SECTION
BUILD-OUT MOUNT

PROJECT NO. 415-0109

		JBH	BY
	04/30/15	RJA	DATE
B	UPDATE TO 5TH EDITION (2014) FBC		
A	CORRECT FASTENER SPACING ERROR		
REV	DESCRIPTION		

HURRICANE STORM PANEL MFG. INC.

1720 MAIN ST. NE. UNIT 1
PALM BAY, FL 32905

HVHZ IMPACT STORM PANEL
VERTICAL SECTIONS

DATE:	05/30/13
DRAWING NO.:	HSPM0001
SCALE:	N.T.S.
REV:	B
SHEET:	2 OF 7

PREPARED BY:



Robert J. Amoruso
Florida P.E. No. 49752

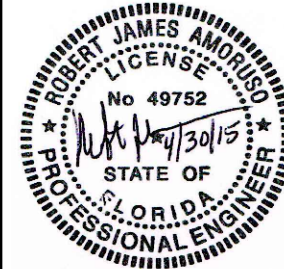

PTC Product Design Group, LLC
P.O. Box 520775
Longwood, FL 32752-0775
FBPE Cert. of Authorization NO. 25935

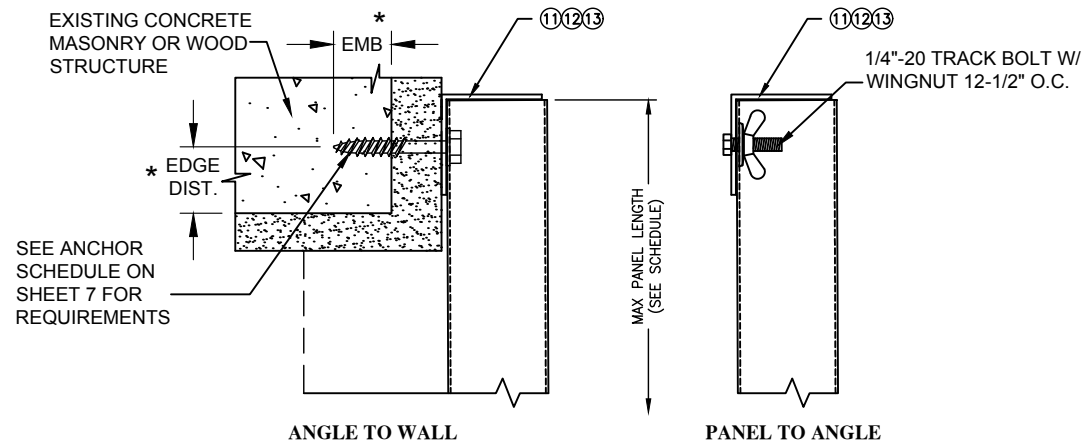

VERTICAL SECTION
WALL MOUNT

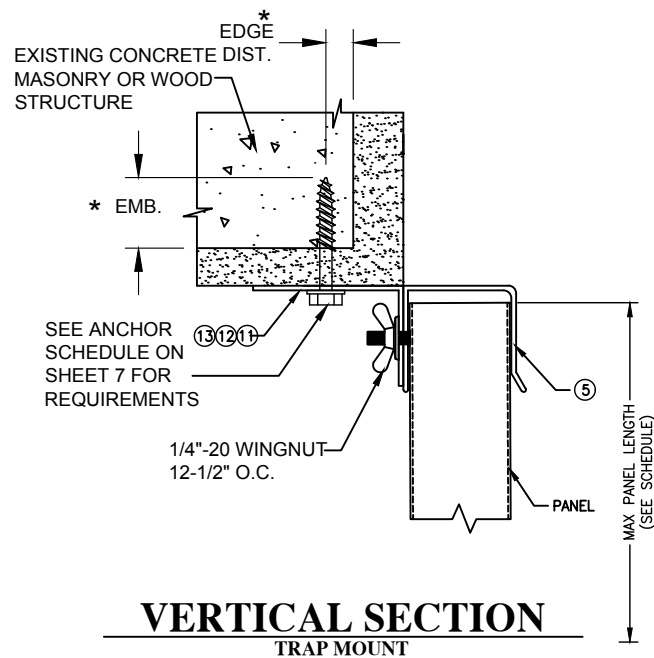

VERTICAL SECTION
TRAP MOUNT

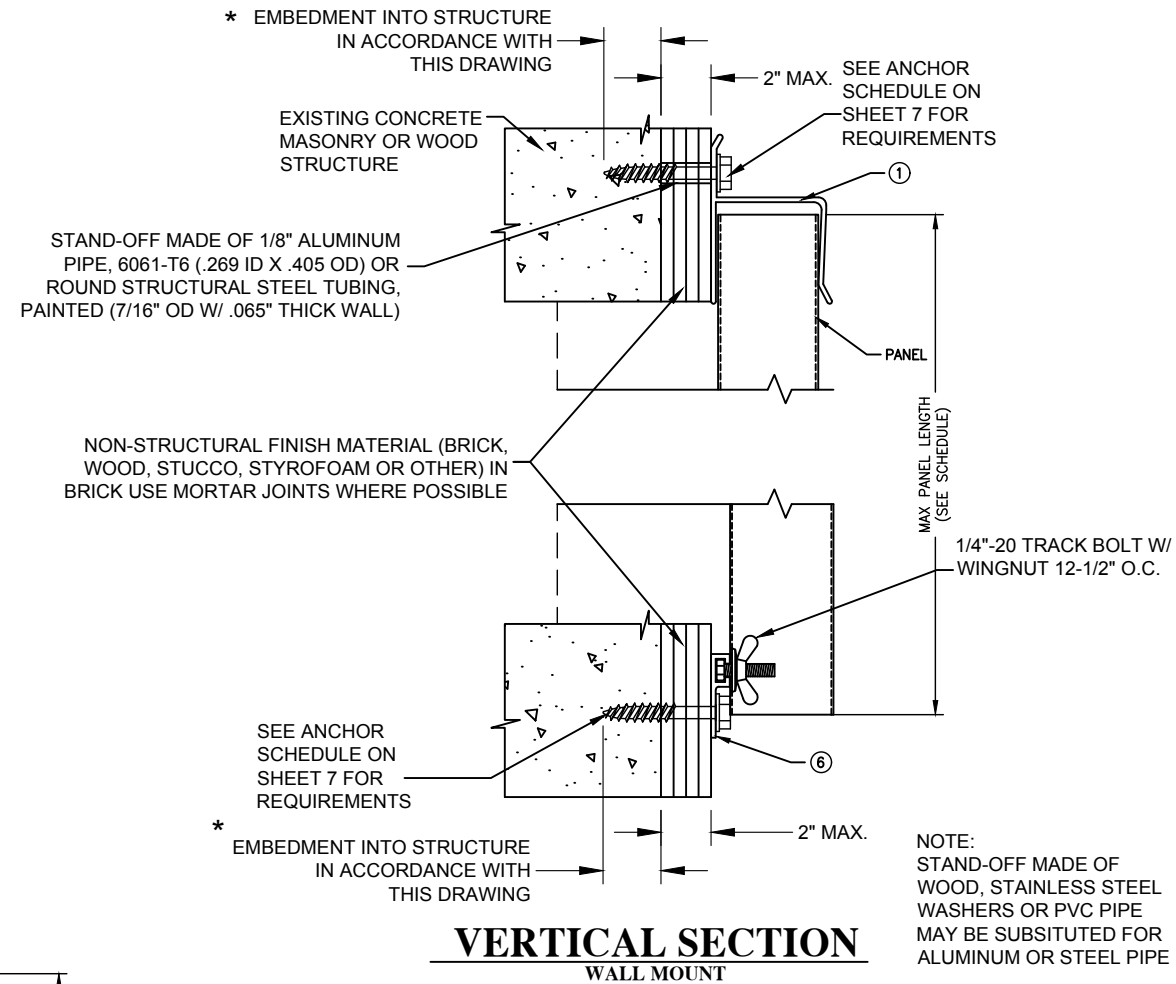

VERTICAL SECTION
WALL MOUNT

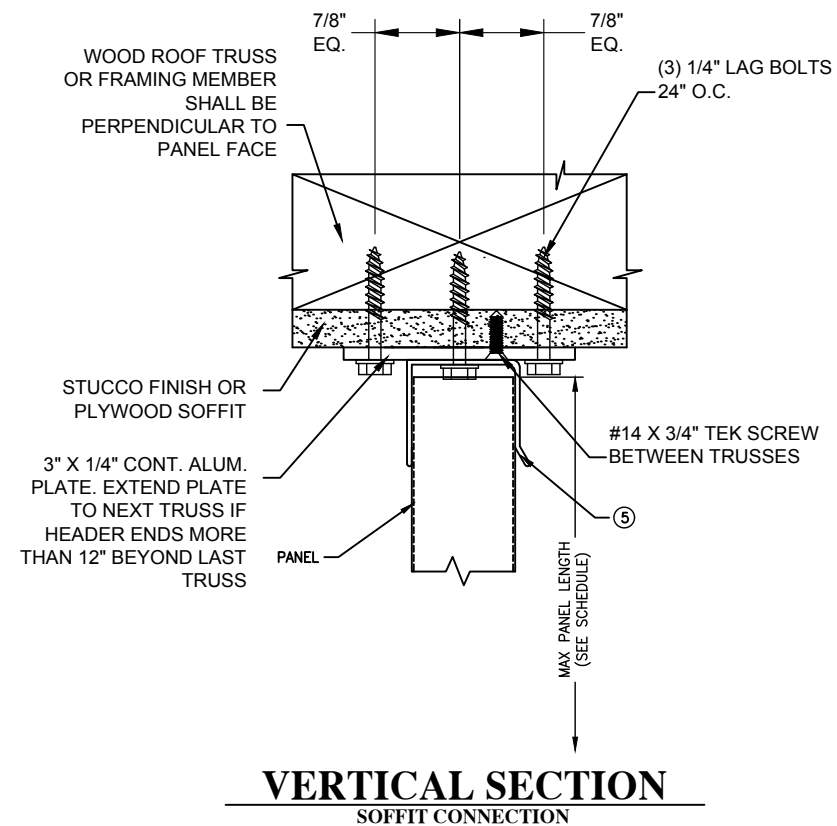

VERTICAL SECTION
SOFFIT CONNECTION

* SEE ANCHOR SCHEDULE SHEET 7

PROJECT NO. 415-0109

		JBH	BY
	04/30/15	RJA	DATE
B	UPDATE TO 5TH EDITION (2014) FBC		
A	CORRECT FASTENER SPACING ERROR		
REV	DESCRIPTION		

HURRICANE STORM PANEL MFG. INC.
1720 MAIN ST. NE. UNIT 1
PALM BAY, FL 32905

HVHZ IMPACT STORM PANEL
VERTICAL SECTIONS

DATE:	05/30/13
DRAWING NO.:	HSPM0001
SHEET:	3 OF 7
DRAWN BY:	RJA
SCALE:	N.T.S.
REV:	B

PREPARED BY: **PTE**

Robert J. Amoruso
Florida P.E. No. 49752

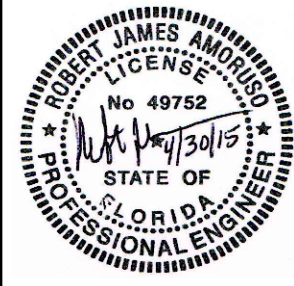

PTC Product Design Group, LLC
P.O. Box 520775
Longwood, FL 32752-0775
FBPE Cert. of Authorization NO. 25935

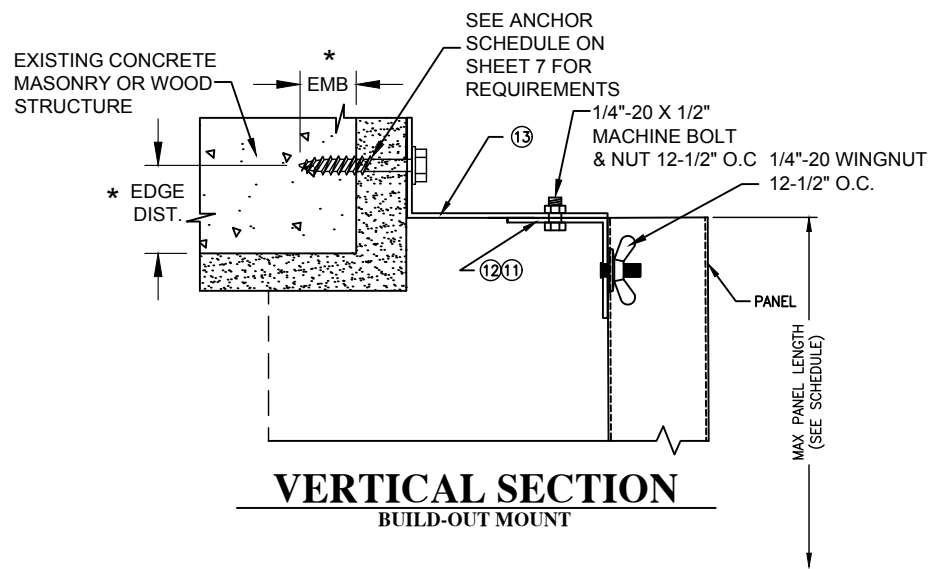

VERTICAL SECTION
BUILD-OUT MOUNT

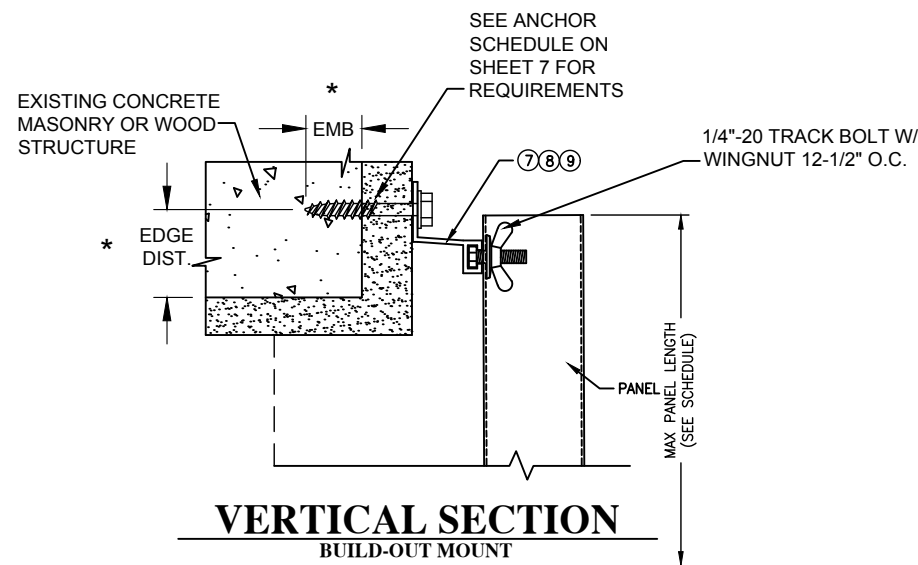

VERTICAL SECTION
BUILD-OUT MOUNT

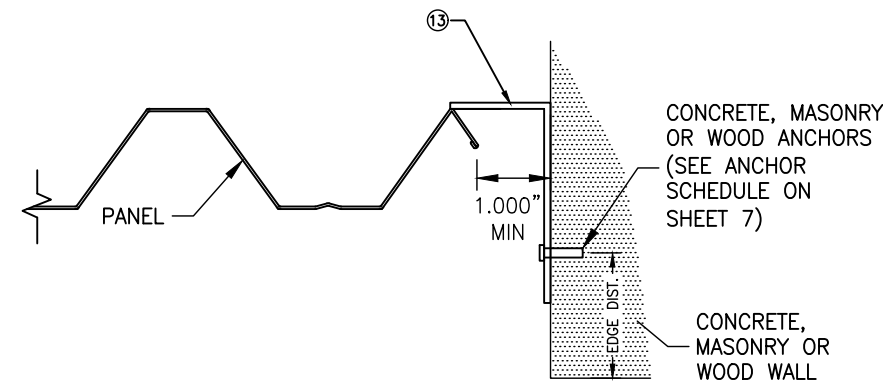

HORIZONTAL SECTION
END CLOSURE (SEE INSTALLATION
NOTE 7 ON SHEET 1)

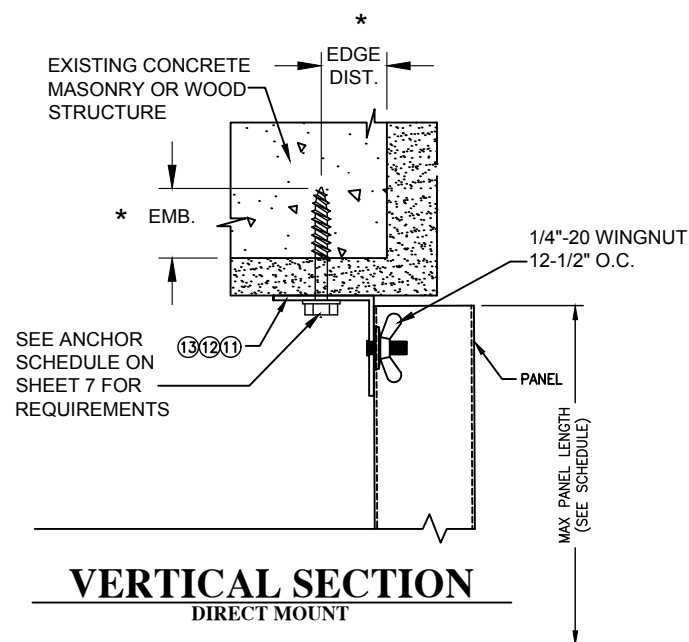

VERTICAL SECTION
DIRECT MOUNT

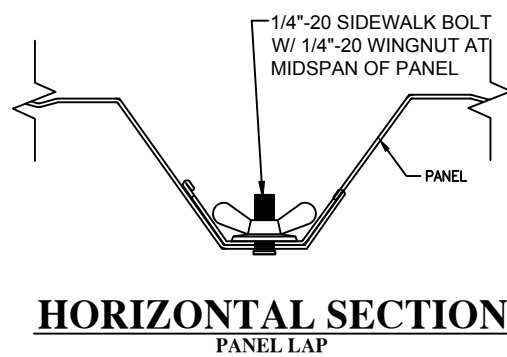

HORIZONTAL SECTION
PANEL LAP

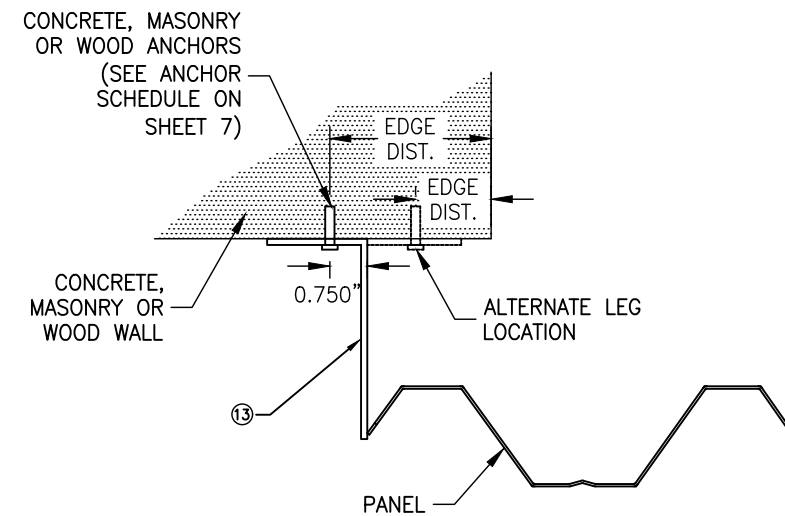

HORIZONTAL SECTION
END CLOSURE (SEE INSTALLATION
NOTE 7 ON SHEET 1)

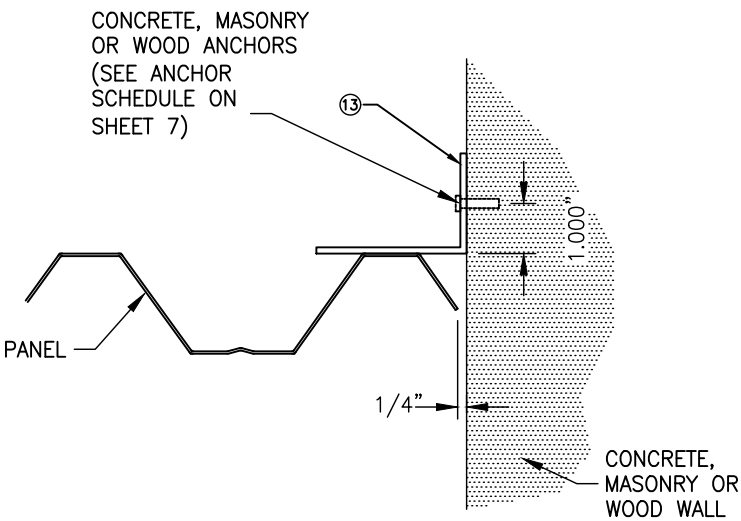

HORIZONTAL SECTION
END CLOSURE (SEE INSTALLATION
NOTE 7 ON SHEET 1)

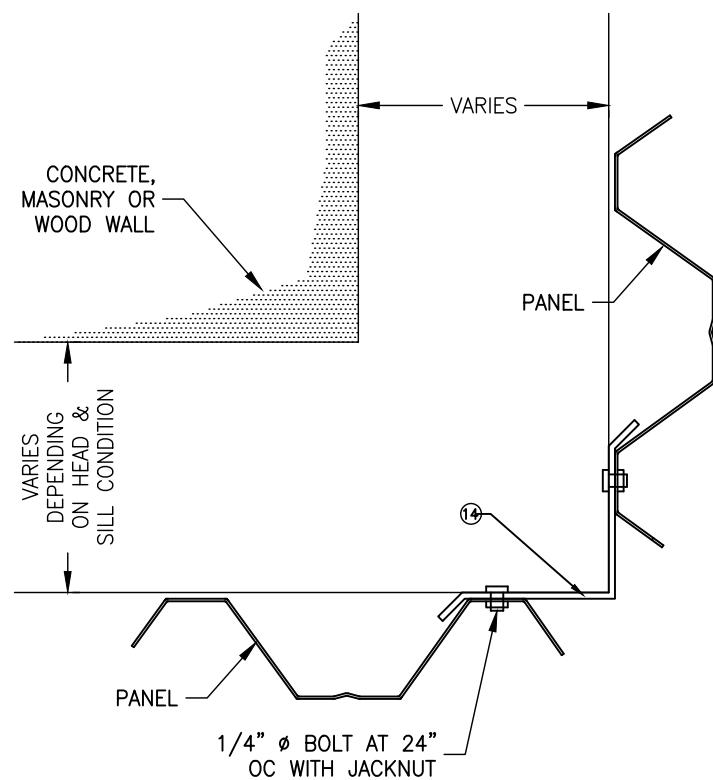

HORIZONTAL SECTION
END CLOSURE (SEE INSTALLATION
NOTE 7 ON SHEET 1)

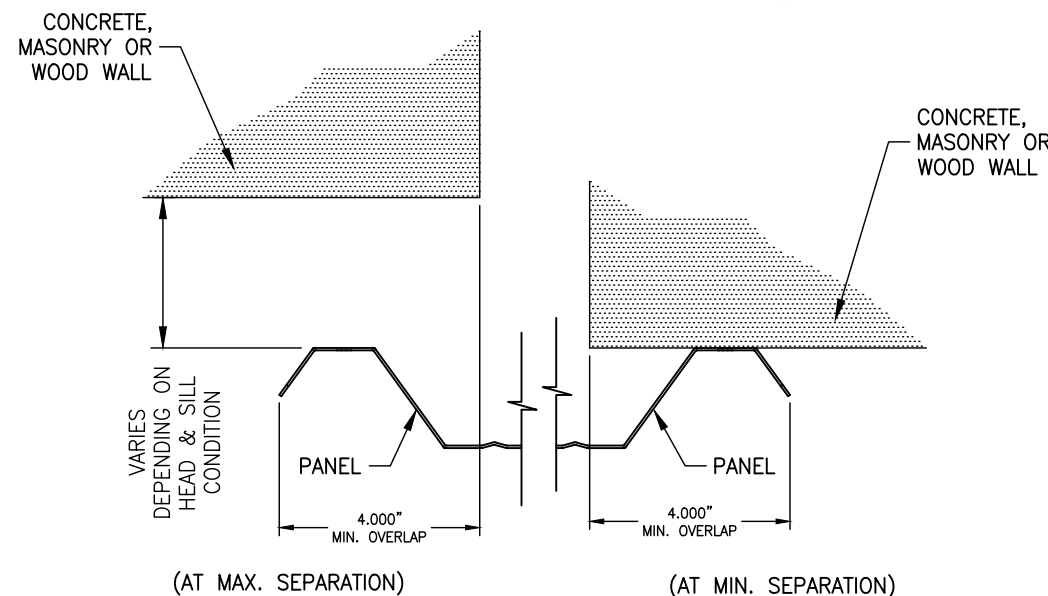

HORIZONTAL SECTION
END CLOSURE (SEE INSTALLATION
NOTE 7 ON SHEET 1)

* SEE ANCHOR SCHEDULE
SHEET 7

PROJECT NO. 415-0109

		JBH	BY
	04/30/15	RJA	DATE
B	UPDATE TO 5TH EDITION (2014) FBC		
A	CORRECT FASTENER SPACING ERROR		
REV	DESCRIPTION		

HURRICANE STORM PANEL MFG. INC.

1720 MAIN ST. NE. UNIT 1
PALM BAY, FL 32905

HVHZ IMPACT STORM PANEL
VERTICAL & HORIZONTAL SECTIONS

DRAWN BY:	RJA	DATE:	05/30/13
SCALE:	N.T.S.	DRAWING NO.:	HSPM0001
REV:	B	SHEET:	4 OF 7

PREPARED BY:
PTE

Robert J. Amoruso
Florida P.E. No. 49752



PTC Product Design Group, LLC
P.O. Box 520775
Longwood, FL 32752-0775
FBPE Cert. of Authorization NO. 25935

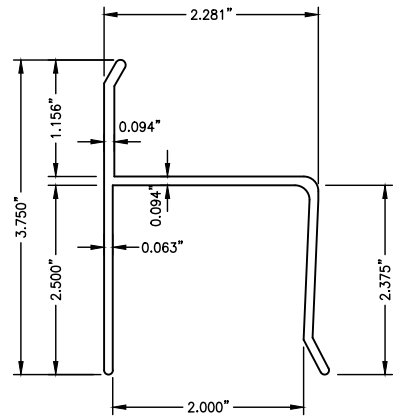

① "H" HEADER
6063-T6 ALUMINUM

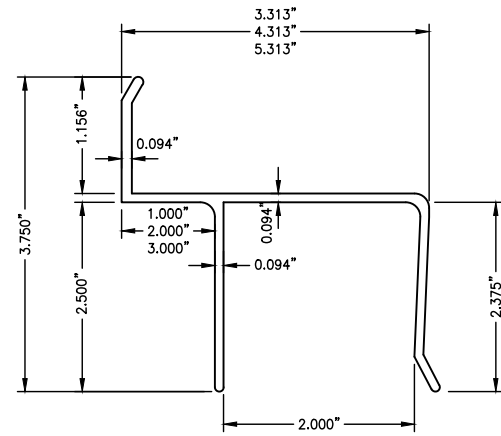

② 1" BUILD-OUT "H" HEADER
6063-T6 ALUMINUM
③ 2" BUILD-OUT "H" HEADER
6063-T6 ALUMINUM
④ 3" BUILD-OUT "H" HEADER
6063-T6 ALUMINUM

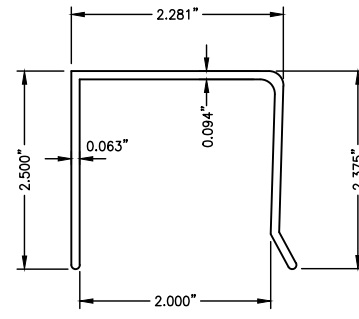

⑤ "U" HEADER
6063-T6 ALUMINUM

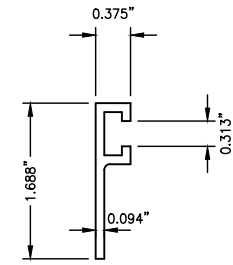

⑥ "F" TRACK
6063-T6 ALUMINUM

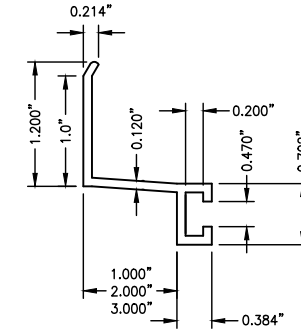

⑦ 1" BUILD-OUT "F" TRACK
6063-T6 ALUMINUM
⑧ 2" BUILD-OUT "F" TRACK
6063-T6 ALUMINUM
⑨ 3" BUILD-OUT "F" TRACK
6063-T6 ALUMINUM

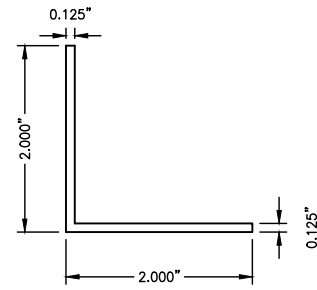

⑪ ANGLE
6063-T6 ALUMINUM

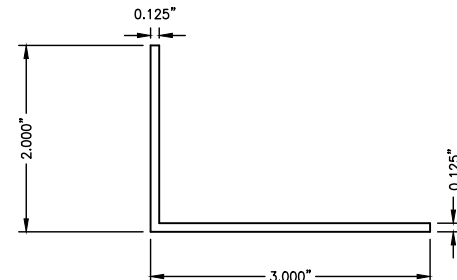

⑫ ANGLE
6063-T6 ALUMINUM

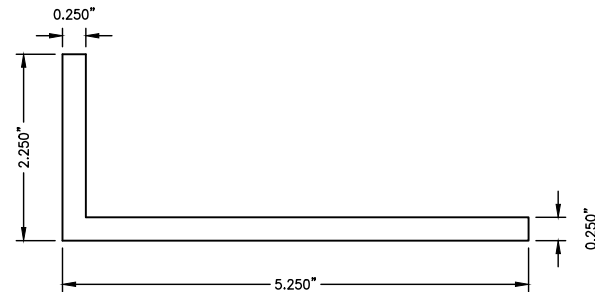

⑬ ANGLE
6063-T6 ALUMINUM

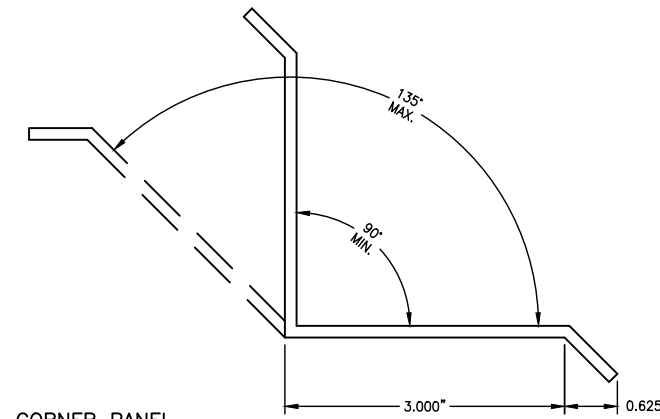

⑭ CORNER PANEL
SEE GENERAL NOTE 3, SHEET 1

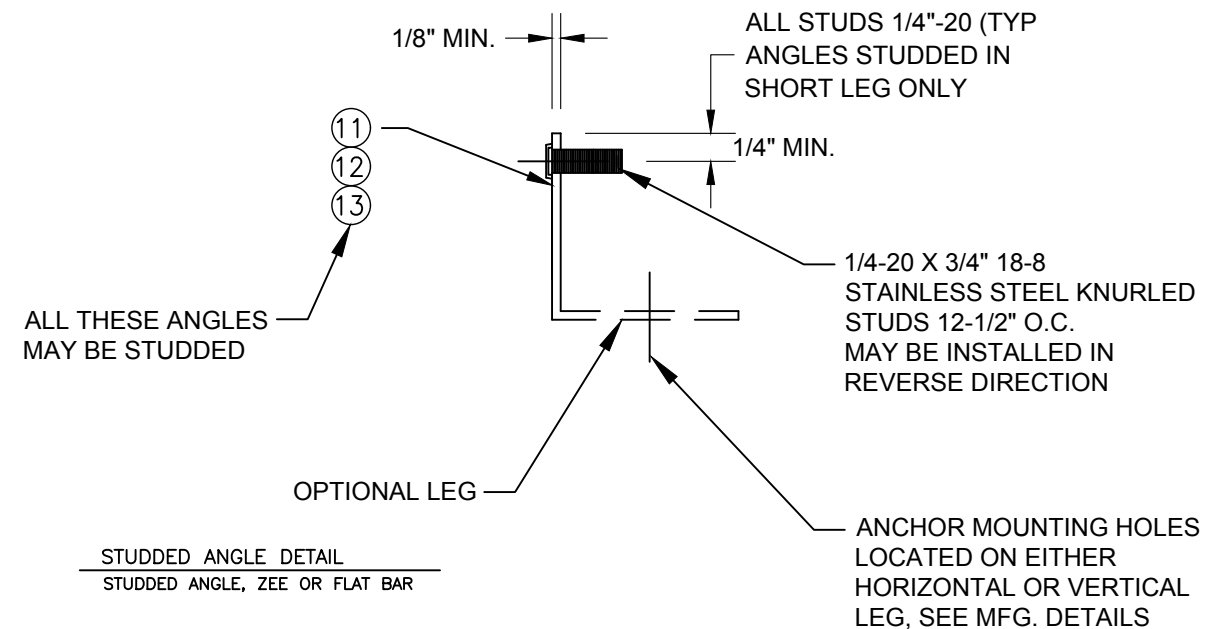
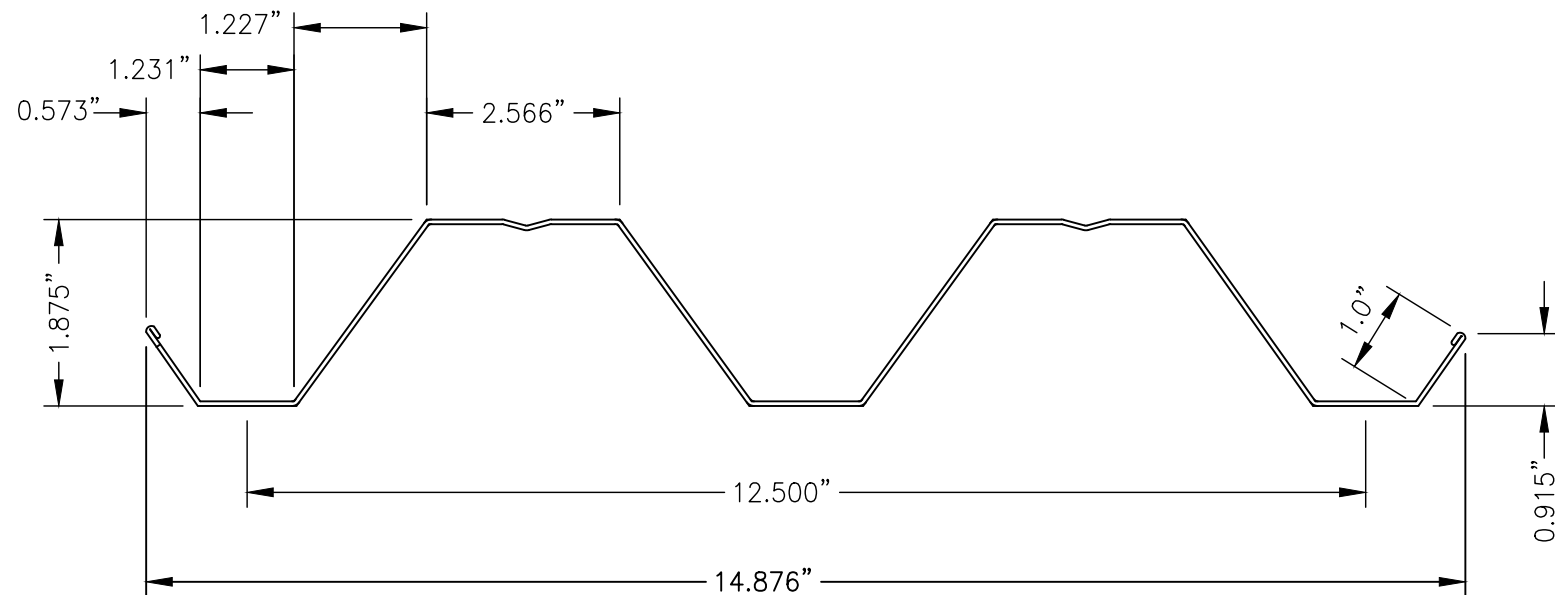

PROJECT NO. 415-0109

		JBH	BY
	04/30/15	RJA	DATE
B	UPDATE TO 5TH EDITION (2014) FBC		
A	CORRECT FASTENER SPACING ERROR		
REV	DESCRIPTION		

HURRICANE STORM PANEL MFG. INC.
1720 MAIN ST. NE. UNIT 1
PALM BAY, FL 32905

TITLE: HVHZ IMPACT STORM PANEL COMPONENTS

DATE: 05/30/13
DRAWING NO: HSPM0001
SHEET: 5 OF 7

DRAWN BY: RJA
SCALE: N.T.S.
REV: B

PREPARED BY: PTC

Robert J. Amoruso
Florida P.E. No. 49752

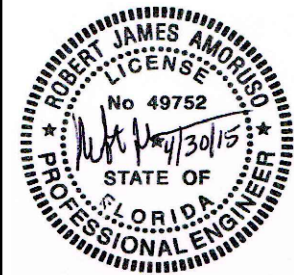

PTC Product Design Group, LLC
P.O. Box 520775
Longwood, FL 32752-0775
FBPE Cert. of Authorization NO. 25935

PANEL DP TABLE

PANEL DP TABLE NOTES:

- ENTER PANEL DP TABLE WITH POSITIVE AND NEGATIVE DESIGN LOAD TO DETERMINE MAX. LENGTH. POSITIVE LOADS LESS THAN NEGATIVE LOADS ARE ACCEPTABLE.
- FOR DESIGN LOADS BETWEEN TABULATED VALUES, USE NEXT HIGHER LOAD OR LINEAR INTERPOLATION TO DETERMINE ALLOWABLE DESIGN PRESSURE BASED ON INSTALLED PANEL LENGTH.

0.050" Aluminum				
Design Pressure		Max. Panel Length (L) (in)	Panel Length Range (L) (in)	Mid-Point Fastener Required per Elevation
Positive	Negative			
28	28	144	from 138 to 144	yes
31	31	138	from 132 to 138	yes
34	34	132	from 126 to 132	yes
37	37	126	from 120 to 126	yes
40	40	120	from 114 to 120	no
43	43	114	from 108 to 114	no
46	46	108	from 106 to 108	no
47	47	106	from 102 to 106	no
49	49	102	from 96 to 102	no
52	52	96	from 90 to 96	no
55	55	90	from 84 to 90	no
58	58	84	from 78 to 84	no
61	61	78	from 72 to 78	no
64	64	72	from 56 to 72	no
72	72	56	from 43 to 56	no
79	79	43	0 to 43	no

24 Ga. Galvanized Steel				
Design Pressure (psf)		Max. Panel Length (L) (in)	Panel Length Range (L) (in)	Mid-Point Fastener Required per Elevation
Positive	Negative			
25	28	144	from 138 to 144	yes
27	29	138	from 132 to 138	yes
29	31	132	from 126 to 132	yes
31	32	126	from 120 to 126	yes
33	34	120	from 114 to 120	yes
35	35	114	from 108 to 114	no
37	38	108	from 106 to 108	no
38	39	106	from 102 to 106	no
39	41	102	from 96 to 102	no
41	44	96	from 90 to 96	no
43	47	90	from 84 to 90	no
45	50	84	from 78 to 84	no
47	53	78	from 72 to 78	no
49	56	72	from 56 to 72	no
54	64	56	from 43 to 56	no
59	71	43	0 to 43	no

PANEL SEPARATION TABLE

SEPARATION REQUIREMENTS - WIND ZONES 1, 2, 3 AND 4 NOT INCLUDING THE HIGH VELOCITY HURRICANE ZONE (HVHZ)

- REQUIRED (MANDATORY) SEPARATION REQUIREMENTS:
 - PER ASTM E1996-02 UNDER WHICH THIS PRODUCT WAS TESTED AND APPROVED IN THIS PRODUCT APPROVAL DOCUMENT AND IN ACCORDANCE WITH THE CURRENT EDITION FLORIDA BUILDING CODE, ONLY POROUS SHUTTER ASSEMBLIES REQUIRE SEPARATION OF THE SHUTTER ASSEMBLY FROM THE FENESTRATION UNIT.
 - THIS PRODUCT IS A NON-POROUS SHUTTER ASSEMBLY. THEREFORE SEPARATION IS NOT REQUIRED BY ASTM E1996-02 AS ADOPTED BY THE CURRENT EDITION FLORIDA BUILDING CODE.
 - THE MANUFACTURER RECOMMENDS THE USER MAINTAIN A NON-MANDATORY MINIMUM 1 INCH SEPARATION.
 - SEE ITEM 2 BELOW FOR NON-MANDATORY SEPARATION REQUIREMENTS THAT MAY BE EMPLOYED FOR WIND ZONES 1, 2, 3 AND 4 NOT INCLUDING THE HIGH VELOCITY HURRICANE ZONE (HVHZ).
- NON-MANDATORY SEPARATION REQUIREMENTS DERIVED FROM ASTM E1996-09:
 - THIS PRODUCT IS NOT TESTED OR APPROVED FOR ASTM E1996-09, THEREFORE THE FOLLOWING IS FOR GUIDANCE ONLY AND IS NON-MANDATORY TO THIS APPROVAL.
 - THIS PRODUCT WAS TESTED FOR WIND ZONES 1 THROUGH 4, MISSILE LEVEL D.
 - FOR NON ESSENTIAL FACILITIES (I.E. BASIC PROTECTION), SEPARATION OF THE SHUTTER ASSEMBLY FROM THE FENESTRATION UNIT IS NOT REQUIRED.
 - THE MANUFACTURER RECOMMENDS THE USER MAINTAIN A NON-MANDATORY MINIMUM 1 INCH SEPARATION.
 - FOR ESSENTIAL FACILITIES, SEPARATION OF THE SHUTTER ASSEMBLY FROM THE FENESTRATION UNIT IS REQUIRED FOR THE FOLLOWING.
 - FOR ASSEMBLY HEIGHTS < 30 FT. IN WIND ZONES 1 AND 2, THE SEPARATION TABLE BELOW CAN BE USED.
 - FOR ASSEMBLY HEIGHTS < 30 FT. IN WIND ZONES 3 AND 4, THIS PRODUCT DOES NOT MEET ASTM E1996-09 REQUIREMENTS.
 - FOR ASSEMBLY HEIGHTS > 30 FT. IN WIND ZONES 1 THROUGH 4, THE SEPARATION TABLE BELOW CAN BE USED.
 - SEE SEPARATION TABLE BELOW FOR NON-MANDATORY SEPARATION REQUIREMENTS THAT MAY BE EMPLOYED.

SEPARATION REQUIREMENTS - HIGH VELOCITY HURRICANE ZONE (HVHZ)

- PER THE CURRENT EDITION FLORIDA BUILDING CODE, CHAPTER 24 AND THE CURRENT EDITION FLORIDA RESIDENTIAL CODE, CHAPTER 44, THE STORM SHUTTER SHALL BE DESIGNED AND CONSTRUCTED TO INSURE A MINIMUM OF 1 INCH (25 MM) SEPARATION AT MAXIMUM DEFLECTION.
- THE SEPARATION TABLE BELOW SHALL BE USED TO ASCERTAIN MINIMUM SEPARATION IS MAINTAINED MEETING THESE REQUIREMENTS.

0.050" Aluminum	
Max. Panel Length (L) (in)	Minimum Separation Distance (in)
144	5.703
138	5.625
132	5.547
126	5.469
120	5.391
114	5.328
108	5.266
106	5.245
102	5.203
96	5.141
90	5.078
84	5.016
78	4.963
72	4.913
56	4.779
43	4.671

24 Ga. Galvanized Steel	
Max. Panel Length (L) (in)	Minimum Separation Distance (in)
144	5.625
138	5.594
132	5.563
126	5.531
120	5.500
114	5.469
108	5.438
106	5.427
102	5.406
96	5.375
90	5.344
84	5.313
78	5.281
72	5.250
56	5.167
43	5.099

NOTE FOR SEPARATION TABLE:

- THIS TABLE'S SEPARATION DISTANCE REQUIREMENTS ENVELOPE THAT REQUIRED BY ASTM E1996 AND THE CURRENT EDITION FLORIDA BUILDING CODE, CHAPTER 24 AND THE CURRENT EDITION FLORIDA RESIDENTIAL CODE, CHAPTER 44.

PROJECT NO. 415-0109		JBH	BY
	UPDATE TO 5TH EDITION (2014) FBC	04/30/15	DATE
	CORRECT FASTENER SPACING ERROR	8/14/13	RJA
	B	A	REV
			DESCRIPTION

HURRICANE STORM PANEL MFG. INC. 1720 MAIN ST. NE. UNIT 1 PALM BAY, FL 32905	HVHZ IMPACT STORM PANEL PANEL DP SCHEDULE AND SEPARATION SCHEDULE	DATE:	05/30/13
		DRAWING NO:	HSPM0001
		DRAWN BY:	RJA
		SCALE:	N.T.S.
		REV:	B
		SHEET:	6 OF 7



Robert J. Amoruso
Florida P.E. No. 49752

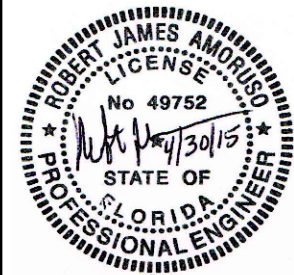

PTC Product Design Group, LLC
P.O. Box 520775
Longwood, FL 32752-0775
FBPE Cert. of Authorization NO. 25935

1/4" DIA. SUBSTRATE ANCHOR SCHEDULE

FASTENER TYPE	SUBSTRATE		MINIMUM EMBEDMENT (in.)	MINIMUM EDGE DIST. (in.)	MIN. SPACING BETWEEN FASTENERS (in.)	DIAMETER (in.)	ON CENTER (O.C.) SPACING (in.)
	TYPE	STRENGTH					
1/4" DIA. WOOD SCREW							
LAG SCREW	S-P-F	SG = 0.42	1 7/8	1	1 1/4	1/4	12
TAPCON SG	S-P-F	SG = 0.42	1 1/2	3/4	1 1/4	1/4	12
SAMMYS SHUTTER SCREWS	S-P-F	SG = 0.42	1 1/2	3/4	1 1/4	1/4	12
FEMALE ELCO PANELMATE	S-P-F	SG = 0.42	1 7/8	3/4	1 1/4	1/4	12
ELCO PANELMATE PLUS	S-P-F	SG = 0.42	1 7/8	3/4	1	1/4	12
1/4" DIA. CONCRETE SCREW IN CONCRETE / MASONRY							
ELCO CRETE-FLEX SS4	CONCRETE	3350 PSI	1 3/4	1 3/4	2 1/4	1/4	12
ITW TAPCON (CS)	CONCRETE	2000 PSI	1 3/4	3	3	1/4	12
ITW TAPCON (SS) (SCOTS)	CONCRETE	3000 PSI	1 3/4	2 1/2	3	1/4	12
ELCO TAPCON	CONCRETE	2700 PSI	1 3/4	1	4	1/4	12
POWERS TAPPER	CONCRETE	2000 PSI	1 3/4	4	2 1/2	1/4	12
ELCO PANELMATE PLUS	CONCRETE	3350 PSI	1 3/4	2 1/2	∅	1/4	12
POWERS CALK-IN	CONCRETE	2000 PSI	7/8	2	1 1/4	1/4	12
TAPCON SG	CONCRETE	3295 PSI	1 3/4	1 1/4	3	1/4	12
SAMMYS SHUTTER SCREWS	CONCRETE	3295 PSI	2 1/4	1 1/4	3	1/4	12
1/4" DIA. CONCRETE SCREW IN CMU HOLLOW							
TAPCON SG	CMU HOLLOW	1500	1 1/4	2 1/2	3	1/4	12
SAMMYS SHUTTER SCREWS	CMU HOLLOW	1500	1 1/4	2 1/2	3	1/4	8
POWERS CALK-IN	1500	C90	7/8	3	2 1/2	1/4	8
1/4" DIA. CONCRETE SCREW IN CMU GROUT FILLED							
SAMMYS SHUTTER SCREWS	CMU GROUT FILLED	2000	2 1/2	1 1/4	3	1/4	12
TAPCON SG	CMU GROUT FILLED	2000	1 3/4	1 1/4	3	1/4	12

ANCHOR SCHEDULE ABOVE FOR USE WITH WOOD, CONCRETE OR MASONRY SUBSTRATE ANCHORAGE. ATTACHMENT OF SHUTTERS TO BUILD-OUT COMPONENTS OR DIRECTLY TO SUBSTRATE SHALL BE AS SHOWN ON SHEETS 2, 3 AND 4 AT 12-1/2" ON CENTER.

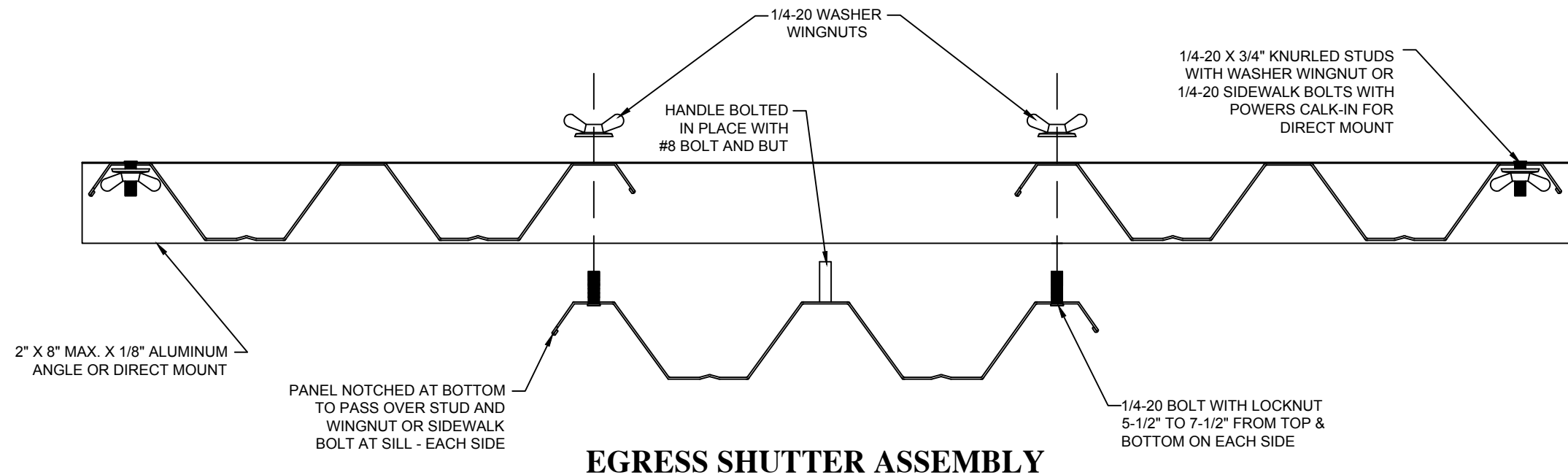

EGRESS SHUTTER ASSEMBLY

PROJECT NO. 415-0109

REV	DESCRIPTION	DATE	BY
B	UPDATE TO 5TH EDITION (2014) FBC	04/30/15	JBH
A	CORRECT FASTENER SPACING ERROR	8/14/13	RJA

HURRICANE STORM PANEL MFG. INC.
1720 MAIN ST. NE. UNIT 1
PALM BAY, FL 32905

TITLE	DATE	SCALE	REV
ANCHOR SCHEDULE AND EGRESS SHUTTER ASSEMBLY	05/30/13	N.T.S.	B
DRAWN BY: RJA	DRAWING NO: HSPM0001		
PREPARED BY: PTC			
			7 OF 7

Robert J. Amoruso
Florida P.E. No. 49752

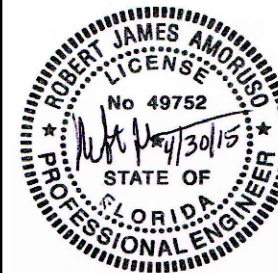

PTC Product Design Group, LLC
P.O. Box 520775
Longwood, FL 32752-0775
FBPE Cert. of Authorization NO. 25935