

GENERAL NOTES:

1. THIS PRODUCT HAS BEEN TESTED TO ASTM E 283, ASTM E 330, AND AAMA 1304 , AND MEETS THE REQUIREMENTS OF THE FLORIDA BUILDING CODE, CURRENT EDITION, FOR USE OUTSIDE THE HIGH VELOCITY HURRICANE ZONE. SEE NOTE 5 BELOW FOR WATER LIMITATIONS.
2. THIS PRODUCT IS NON-IMPACT RESISTANT AND REQUIRES THE USE OF SHUTTERS IN WINDBORNE DEBRIS REGIONS.
3. ALLOWABLE CONFIGURATION: XX (DOUBLE PANEL), X (SINGLE PANEL)
4. THE DESIGN PRESSURE RATINGS FOR THIS PRODUCT AS DETAILED IN THIS DRAWING ARE AS LIMITED BY ASTM E-1300 GLASS TABLES, AND TESTED PRESSURES.
5. THIS PRODUCT IS NOT TESTED FOR WATER INFILTRATION RESISTANCE AND IS INTENDED FOR USE ONLY IN DRY LOCATIONS OR THOSE WITH A 1:1 OVERHANG IN ACCORDANCE WITH THE FBC. SEALING AND FLASHING STRATEGIES FOR OVERALL WATER PERFORMANCE OF INSTALLATION RESPONSIBILITY OF OTHERS.
6. THE 4/3 ALLOWABLE STRESS INCREASE HAS NOT BEEN USED IN THE ANCHOR ANALYSIS FOR THIS SYSTEM. THE 1.6 Cd FACTOR WAS USED IN THE ANALYSIS OF WOOD SUBSTRATE ONLY.
7. INSTALLATION OF WOOD BUCKS TO THE SUBSTRATE TO BE ENGINEERED BY OTHERS OR AS APPROVED BY THE AUTHORITY HAVING JURISDICTION. BUCKING, OPENINGS & BUCKING FASTENERS MUST BE PROPERLY DESIGN & INSTALLED TO TRANSFER WIND LOADS TO THE STRUCTURE.
8. DISSIMILAR MATERIALS THAT COME INTO CONTACT SHALL BE COATED OR OTHERWISE PROTECTED PER FBC TO PREVENT GALVANIC REACTIONS.
9. ALL HARDWARE & FASTENERS SHALL BE IN ACCORDANCE WITH THESE DRAWINGS UNLESS OTHERWISE APPROVED BY A LICENSED DESIGN PROFESSIONAL.
10. SPECIFIED EMBEDMENT TO BASE MATERIAL SHALL BE BEYOND WALL FINISH OR STUCCO.

TABLE OF CONTENTS:

SHEET	DESCRIPTION
1	GEN. NOTES, ELEV. A
2	ELEV. B, ANCHOR LOC. ELEVATIONS, HINGE NOTES
3	INSTALLATION, GLAZING
4	SECTION DETAILS
5	PROFILE DRAWINGS
6	BILL OF MATERIALS

TUBELITE, INC.
NARROW STILE
ALUMINUM OUTSWING
ENTRANCE DOOR

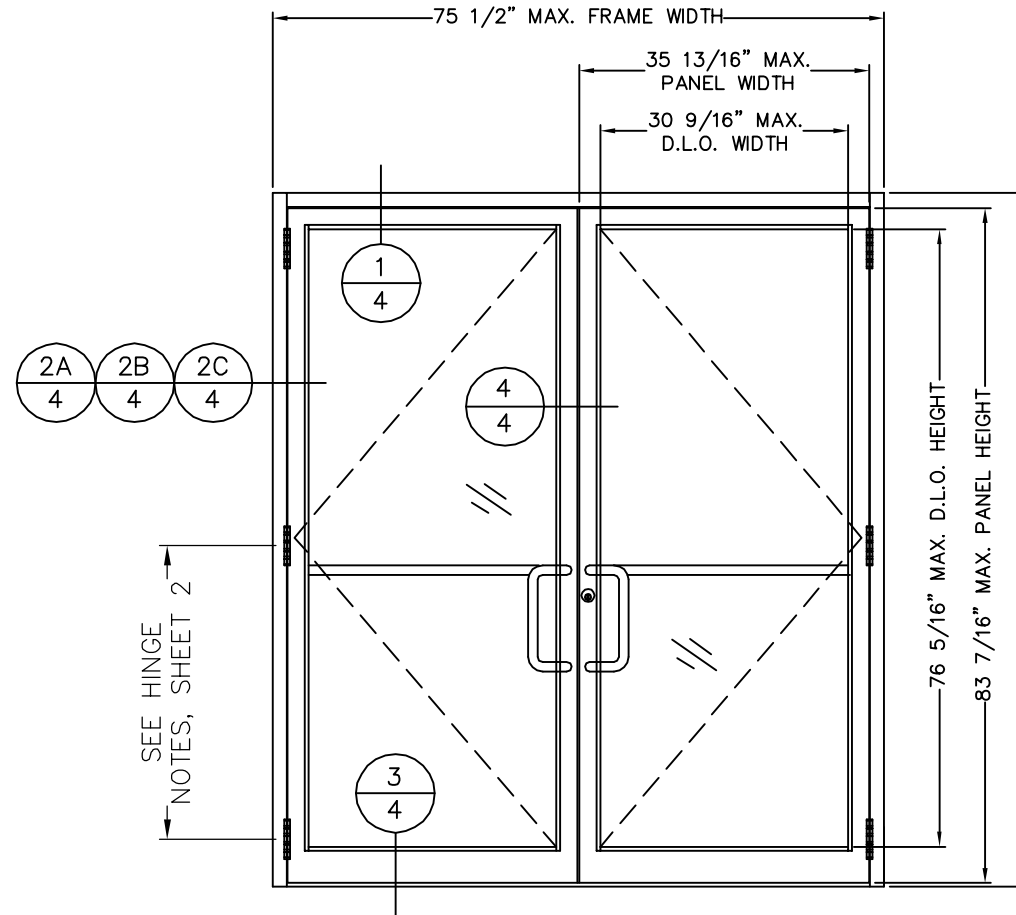

ELEVATION A

3-POINT LOCK ACTIVE, FLUSH BOLTS INACTIVE

ELEVATION A			
QUALIFIED LOCKING HARDWARE	BOTTOM OF DOOR TO LOCK CENTERLINE	DESIGN PRESSURE RATING (+/-PSF)	IMPACT RATING
ACTIVE: ADAMS-RITE 1850A CYLINDER LOCK WITH 2-POINT FLUSH BOLT			
INACTIVE: 1) ADAMS-RITE MS1881, MS2180, OR P1010-OR TWO POINT FLUSH BOLTS 2) INTERNATIONAL F1203 STANDARD FLUSH BOLTS, PART #P059 WITH #P849 GUIDE, ON TOP AND BOTTOM OF PANEL	35"	30	NONE



LT
 10/17/2017
 LUCAS A. TURNER, P.E.
 FL PE # 58201
 TURNER ENGINEERING &
 CONSULTING, INC.
 (COA # 29779)
 1239 JABARA AVE.
 NORTH PORT, FL 34288
 PH. 941-380-1574

TUBELITE
 NARROW STILE
 ENTRANCE DOOR

3055 WALKER RIDGE DRIVE N.W.
 WALKER, MICHIGAN 49544
 PH: 800.566.2227
 FX: 916.301.0097
 WEB SITE: WWW.TUBELITEINC.COM

TUBELITE
 DEPENDABLE
 LEADERS IN ECO-EFFICIENT STOREFRONT,
 CURTAINWALL, AND ENTRANCE SYSTEMS

REVISION HISTORY:

REV	DATE	DESCRIPTION
0	3.4.14	ORIGINAL RELEASE
A	10.17.17	UPDATED HARDWARE

DATE:	03.04.14
DRAWING NUMBER:	FPA-NAR-NI
DRAWN:	
FINAL REVIEW:	
SCALE:	N.T.S.
REVISION:	A
SHEET NAME:	NOTES, HARDWARE, ELEVATION
SHEET:	1 OF 6

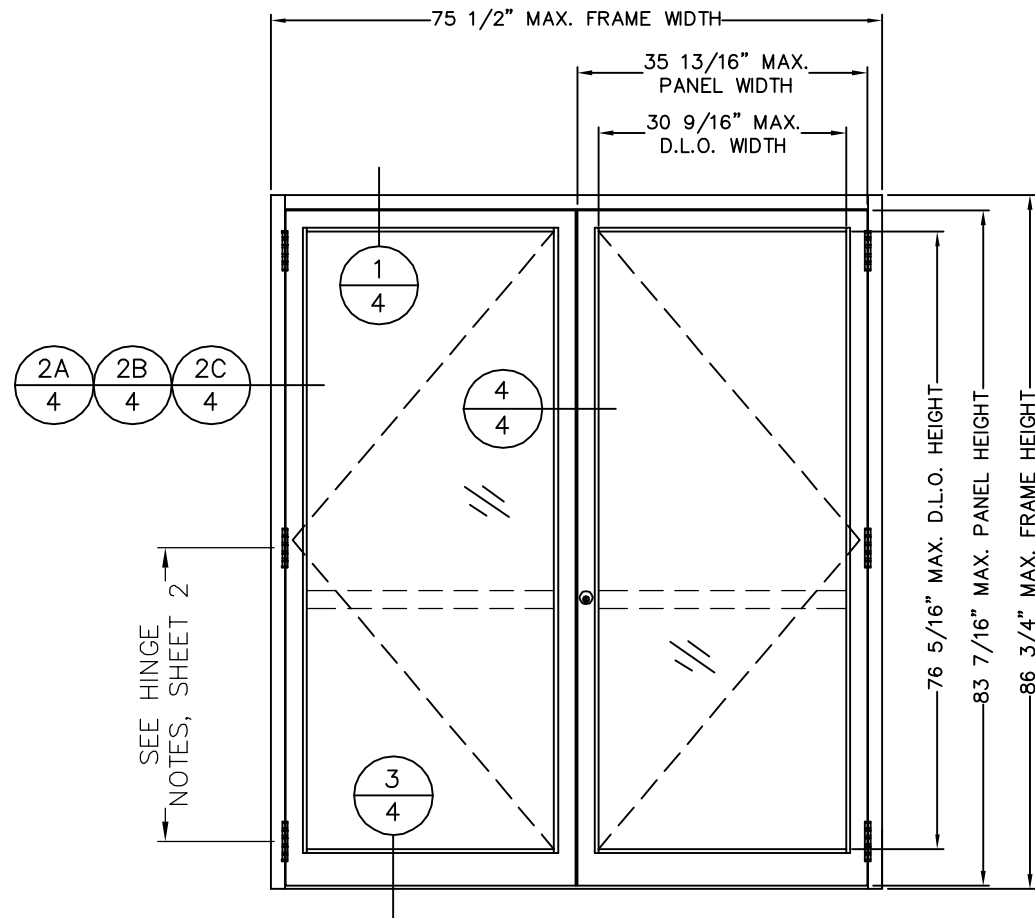

ELEVATION B

CONCEALED VERTICAL ROD / CABLE EXIT DEVICES

INSTALLATION FASTENER LOCATION, TYP., SEE TABLE 1, SHEET 3

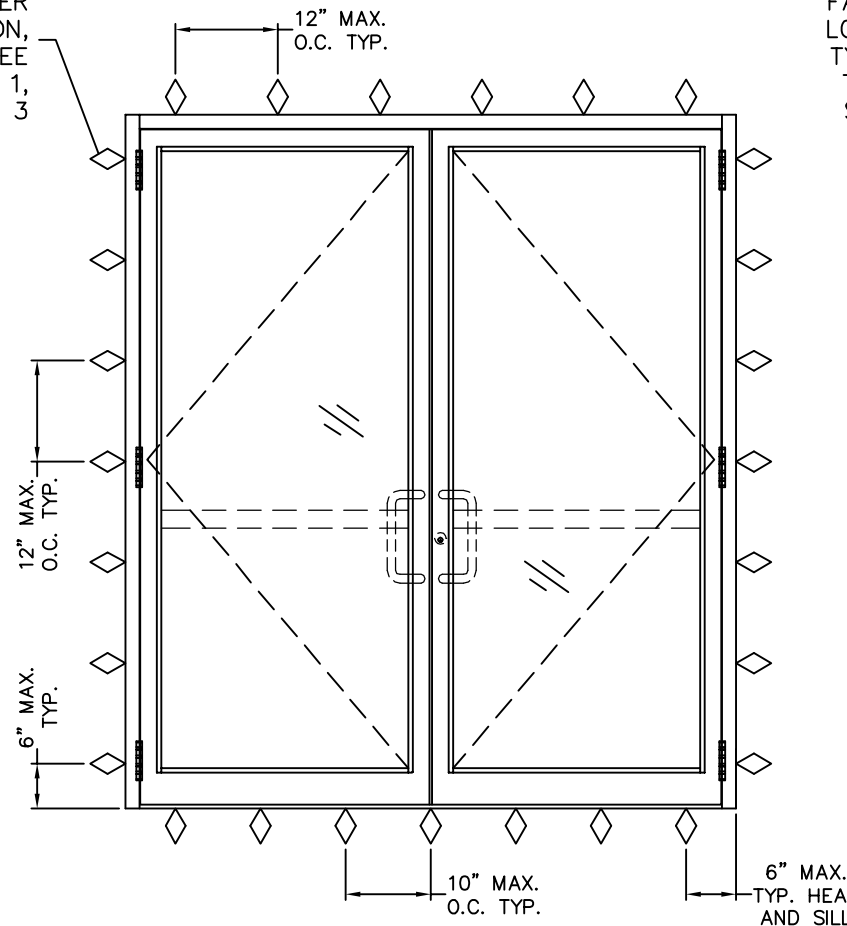

XX ANCHOR LOCATION ELEVATION

INSTALLATION FASTENER LOCATION, TYP., SEE TABLE 1, SHEET 3

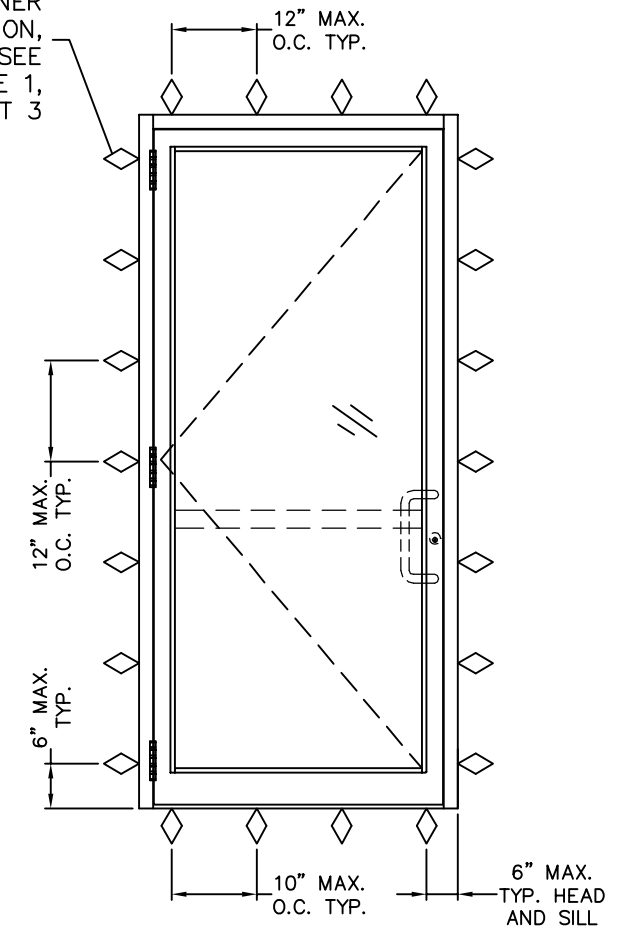

X ANCHOR LOCATION ELEVATION

APPROVED HINGE OPTIONS FOR ELEVATIONS A AND B:

- 1) MORTISED HD HAGER BUTT HINGE BB-1199 WITH REINFORCEMENTS, THREE (3) HINGES PER PANEL AT 6" MAX. FROM TOP AND BOTTOM OF DOOR AND ONE AT MIDSPAN
- 2) RIXON OFFSET PIVOT HINGES 180/147/M19L, THREE (3) HINGES PER PANEL AT TOP AND BOTTOM OF PANEL AND ONE AT MIDSPAN
- 3) CONTINUOUS HINGE: SELECT SL11HD, PEMKO KCFM-95HD1, OR HAGER-ROTON 780

ELEVATION B			
QUALIFIED LOCKING HARDWARE	BOTTOM OF DOOR TO LOCK CENTERLINE	DESIGN PRESSURE RATING (+/-PSF)	IMPACT RATING
FIRST CHOICE 3600 CVR	40 7/8"	30	NONE
VON DUPRIN HH98/9947 CVR	40 5/8"		
VON DUPRIN 98/9949 CV CABLE	40 5/8"		
JACKSON 2086 CVR	40 5/8"		
ADAMS G86 CVR	39 9/16"		
FALCON HSEC 1690 CVR	40 9/16"		
SARGENT AD/MD8400 CVR	40 9/16"		
SARGENT MD8600 CVR	40 9/16"		
CALIBRE 9100 CVR	40 9/16"		
JACKSON 1285 CVR	40 5/8"		



10/17/2017
 LUCAS A. TURNER, P.E.
 FL PE # 58201
 TURNER ENGINEERING & CONSULTING, INC.
 (COA # 29779)
 1239 JABARA AVE.
 NORTH PORT, FL 34288
 PH. 941-380-1574

**TUBELITE
 NARROW STILE
 ENTRANCE DOOR**

3055 WALKER RIDGE DRIVE N.W.
 WALKER, MICHIGAN 49544
 PH: 800.866.2227
 FX: 916.301.0009
 WEB SITE: WWW.TUBELITEINC.COM

TUBELITE
 DEPENDABLE
 LEADERS IN ECO-EFFICIENT STOREFRONT
 CURTAINWALL AND ENTRANCE SYSTEMS

REVISION HISTORY:

REV	DATE	DESCRIPTION
0	3.4.14	ORIGINAL RELEASE
A	10.17.17	UPDATED HARDWARE

DATE:	03.04.14
DRAWING NUMBER:	FPA-NAR-NI
DRAWN:	
FINAL REVIEW:	
SCALE:	N.T.S.
REVISION:	A
SHEET NAME:	ELEV. B, ANCH. LAYOUTS, HINGE NOTES
SHEET:	2 OF 6

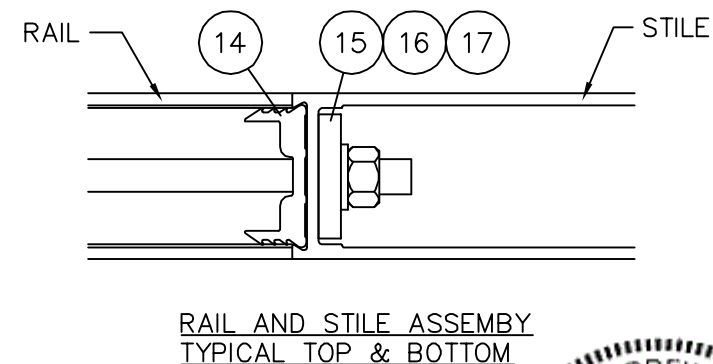
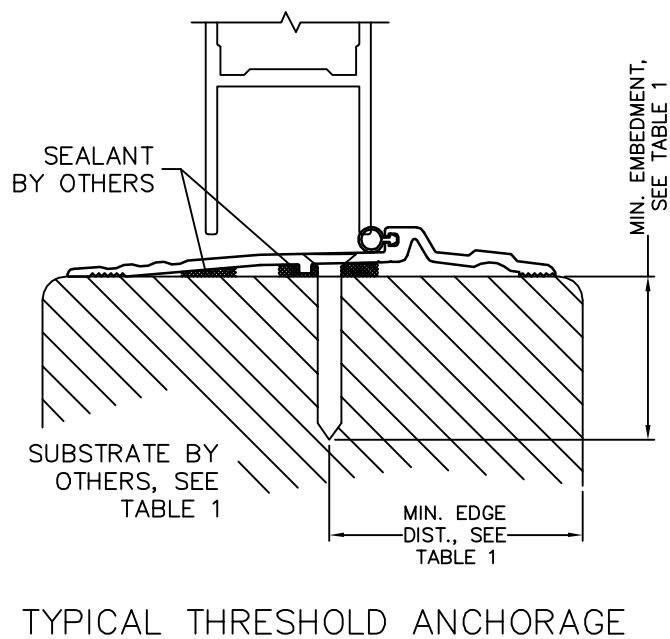
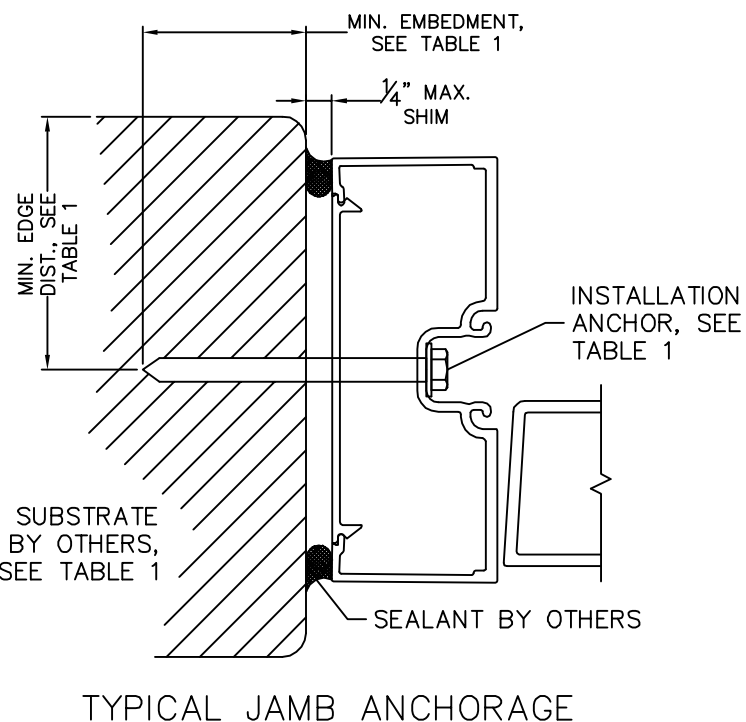
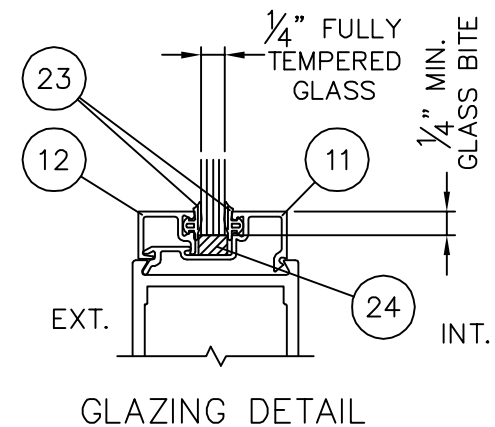
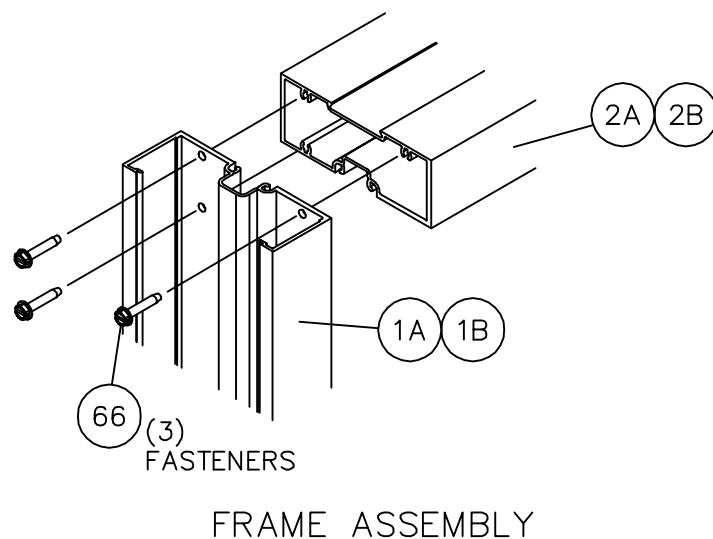
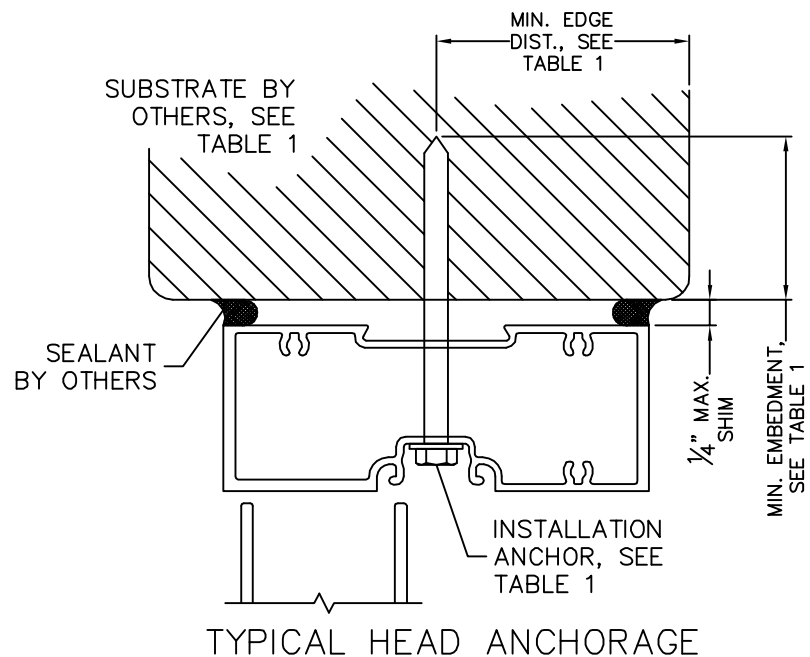

TABLE 1. QUALIFIED ANCHOR INFORMATION

ID	SUBSTRATE	ANCHOR	MIN. EMBEDMENT	MIN. EDGE DISTANCE
A	CONCRETE OR GROUT-FILLED CMU (2850 PSI MIN)	1/4" ELCO COATED CARBON STEEL ULTRACON	1 3/4"	2 1/2"
B	CONCRETE OR GROUT-FILLED CMU (2000 PSI MIN)	1/4" ITW COATED CARBON STEEL TAPCON	1 1/2"	3"
C	CONCRETE (3000 PSI MIN)	1/4" ITW 410 STAINLESS TAPCON	1 3/4"	2 1/2"
D	CONCRETE (3000 PSI MIN)	1/4" HILTI COATED CARBON STEEL OR STAINLESS STEEL KWIK-CON II	1"	2 1/2"
E	HOLLOW OR GROUT-FILLED CMU (ASTM C-90)	1/4" HILTI COATED CARBON STEEL OR STAINLESS STEEL KWIK-CON II	1"	2 1/2"
F	2x MIN. SOUTHERN PINE WOOD (G=0.55 MIN)	#12 GRADE 5 WOOD SCREW	1 3/8"	1"
G	16 GAUGE (0.060") MIN. STEEL STUD 33 KSI YIELD MIN.	#12-24 ITW TEKS SELF-DRILLING SCREW	SEE NOTE	1/2"
H	1/8" ALUM. 6063-T5 MIN. OR 1/8" STEEL 33 KSI MIN.	#12 GRADE 5 SELF-TAPPING / DRILLING SCREW	SEE NOTE	1/2"

NOTE: ANCHORS THROUGH METAL SHALL BE OF SUFFICIENT LENGTH TO PROVIDE THREAD ENGAGEMENT THROUGH THE FULL METAL THICKNESS

TUBELITE
NARROW STILE
ENTRANCE DOOR

3056 WALKER RIDGE DRIVE N.W.
WALKER, MICHIGAN 49544
PH: 800.566.2227
FX: 916.301.0099
WEB SITE: WWW.TUBELITEINC.COM

TUBELITE
DEPENDABLE
LEADERS IN ECO-EFFICIENT STOREFRONT
CURTAINWALL AND ENTRANCE SYSTEMS

REVISION HISTORY:

REV	DATE	DESCRIPTION
0	3.4.14	ORIGINAL RELEASE
A	10.17.17	UPDATED HARDWARE

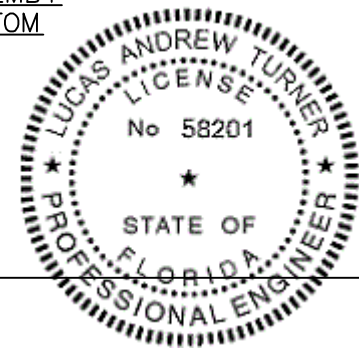

10/17/2017
LUCAS A. TURNER, P.E.
FL PE # 58201
TURNER ENGINEERING &
CONSULTING, INC.
(COA # 29779)
1239 JABARA AVE.
NORTH PORT, FL 34288
PH. 941-380-1574

DATE:	03.04.14
DRAWING NUMBER:	FPA-NAR-NI
DRAWN:	
FINAL REVIEW:	
SCALE:	N.T.S.
REVISION:	A
SHEET NAME:	INSTALLATION, ASSEMBLY, GLAZING DETAIL
SHEET:	3 OF 6

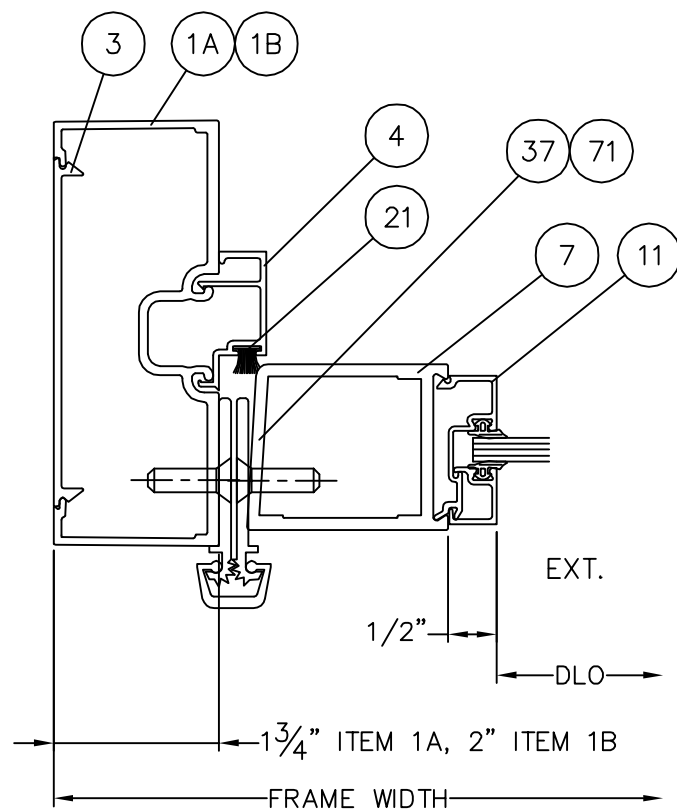

2A
4 JAMB W/CONTINUOUS HINGE
NARROW STILE

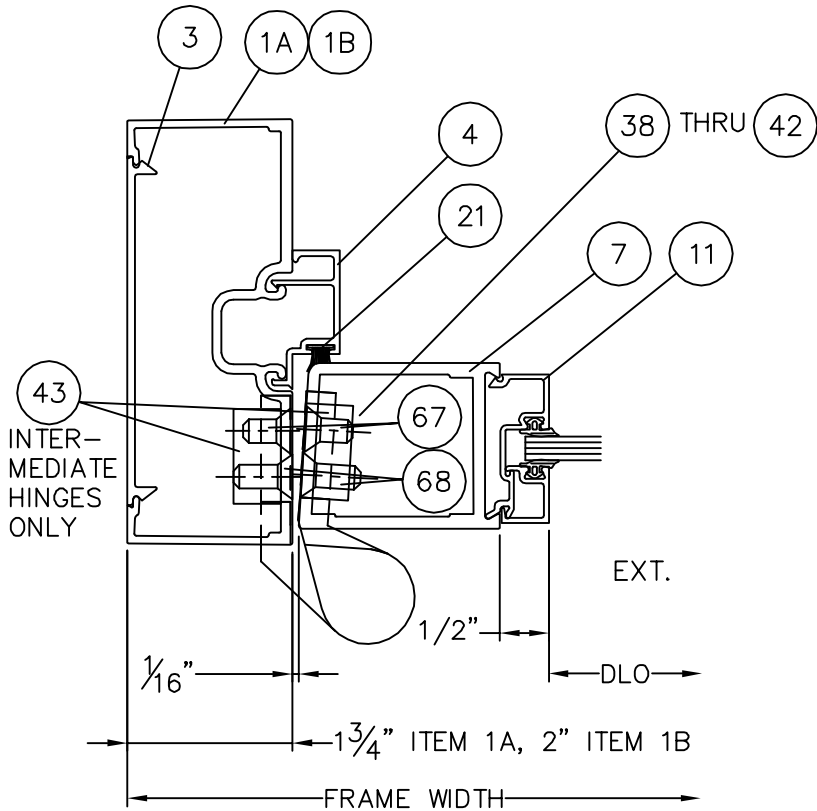

2B
4 JAMB W/ OFFSET PIVOT HINGE
NARROW STILE

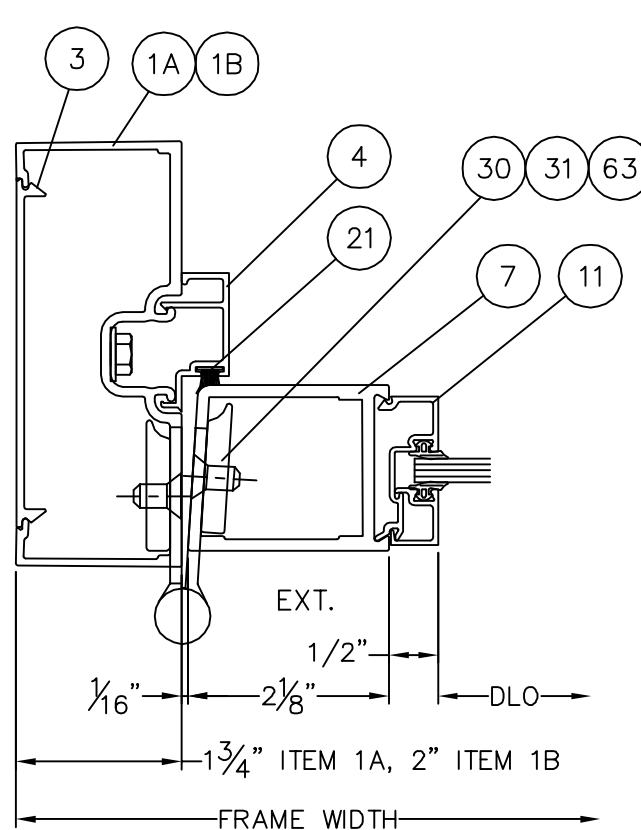

2C
4 JAMB W/BUTT HINGE
NARROW STILE

(4) EA, ITEM 31 TO FRAME & 31 TO STILE.
(4) EA, HINGE TO EACH ITEM 31

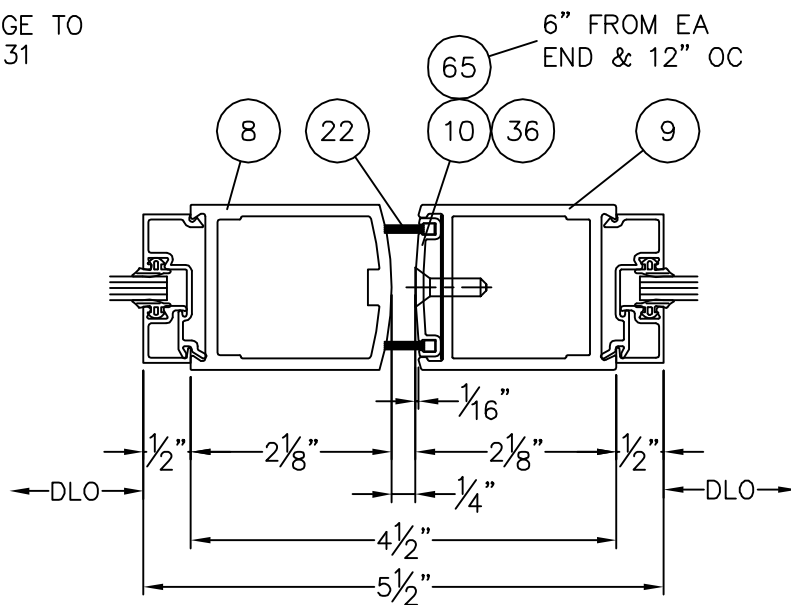

4
4 ASTAGAL
NARROW STILE

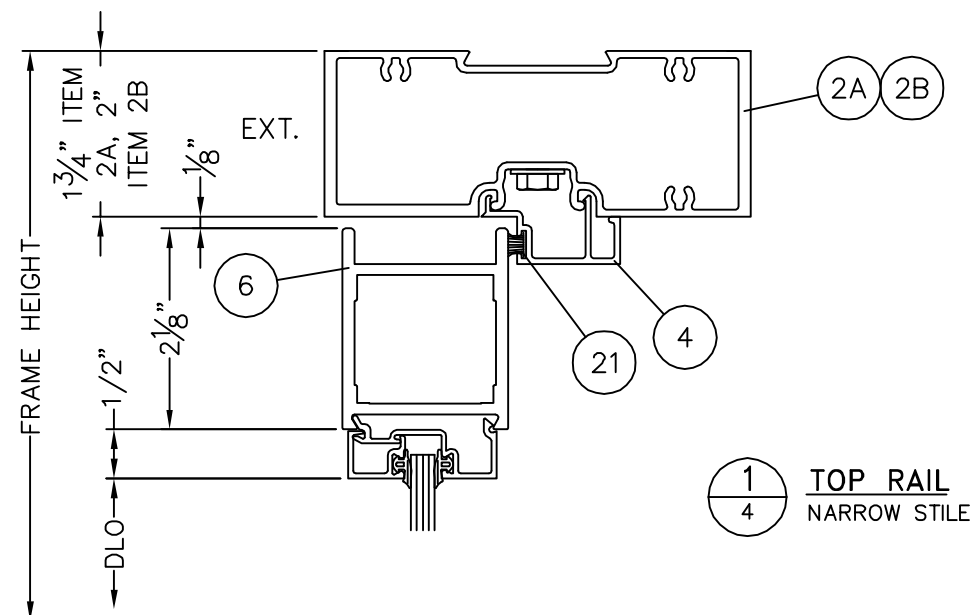

1
4 TOP RAIL
NARROW STILE

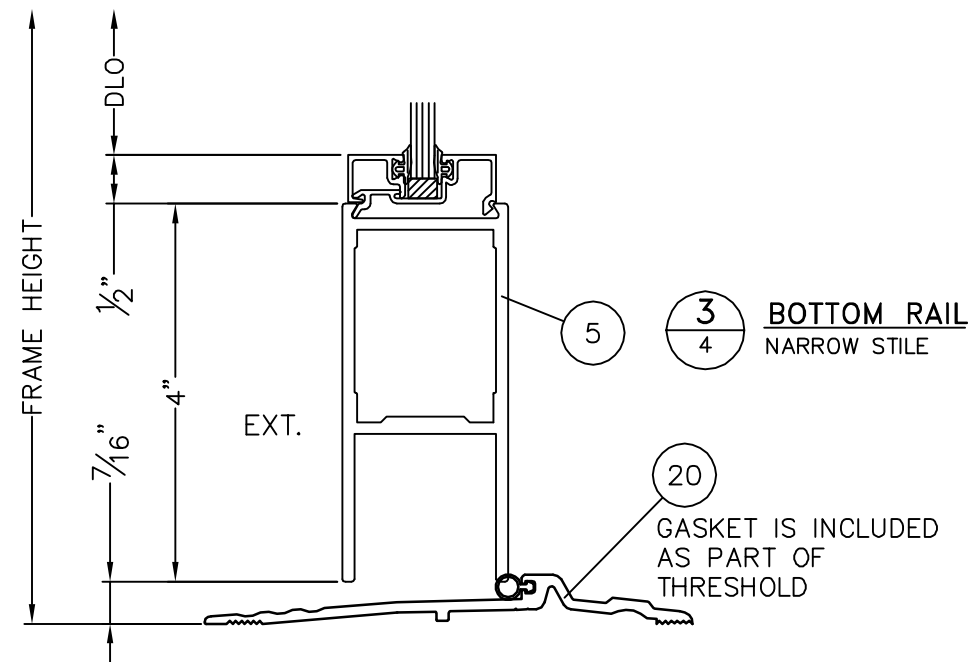

3
4 BOTTOM RAIL
NARROW STILE

**TUBELITE
NARROW STILE
ENTRANCE DOOR**

3055 WALKER RIDGE DRIVE N.W.
WALKER, MICHIGAN 49544
PH: 800.566.2227
FX: 916.301.0009
WEB SITE: WWW.TUBELITEINC.COM

TUBELITE
DEPENDABLE
LEADERS IN ECO-EFFICIENT STOREFRONT
CURTAINWALL AND ENTRANCE SYSTEMS

REVISION HISTORY:

REV	DATE	DESCRIPTION	DRAWN
0	3.4.14	ORIGINAL RELEASE	LT
A	10.17.17	UPDATED HARDWARE	LT

DATE: 03.04.14

DRAWING NUMBER: FPA-NAR-NI

DRAWN:

FINAL REVIEW:

SCALE: N.T.S.

REVISION: A

SHEET NAME:

SECTION DETAILS

SHEET: 4 OF 6



ZZ
10/17/2017
LUCAS A. TURNER, P.E.
FL PE # 58201
TURNER ENGINEERING &
CONSULTING, INC.
(COA # 29779)
1239 JABARA AVE.
NORTH PORT, FL 34288
PH. 941-380-1574

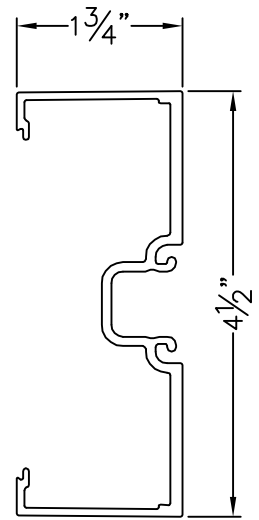

ITEM 1A - E4544
OPEN BACK
DOOR JAMB

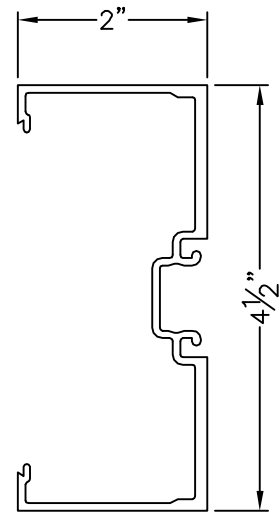

ITEM 1B - E14144
OPEN BACK
DOOR JAMB

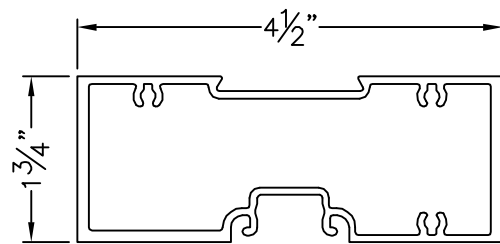

ITEM 2A - E45124
DOOR HEADER

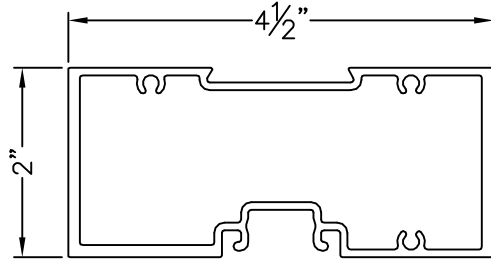

ITEM 2B - E14124
DOOR HEADER

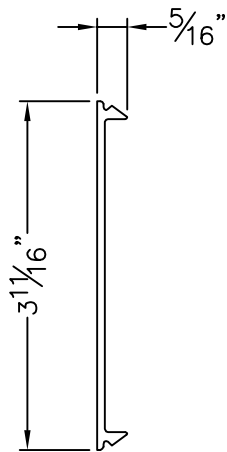

ITEM 3 - E4543
FLAT CLOSURE

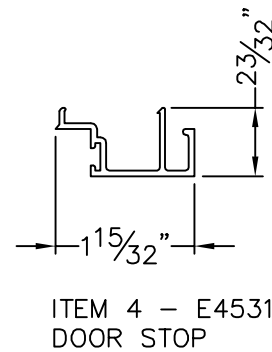

ITEM 4 - E4531
DOOR STOP

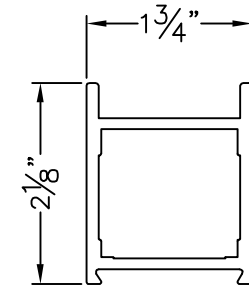

ITEM 6 - E1375
TOP RAIL ~
NARROW STILE

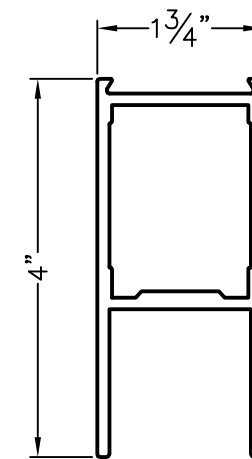

ITEM 5 - E0054
BOTTOM RAIL

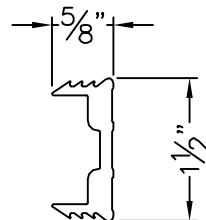

ITEM 14 - E0998
DOOR LUGS

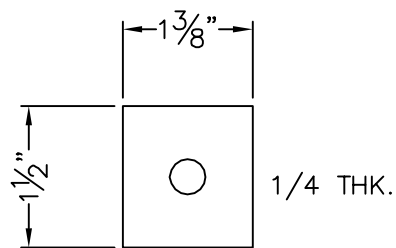

ITEM 16
DOOR ROD WASHER

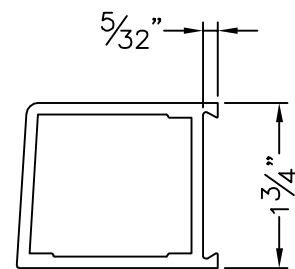

ITEM 7 - E0055
NARROW STILE
BUTT HINGE

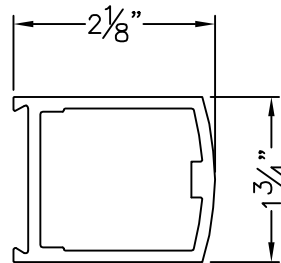

ITEM 8 - E0056
NARROW ROUND FACE STILE

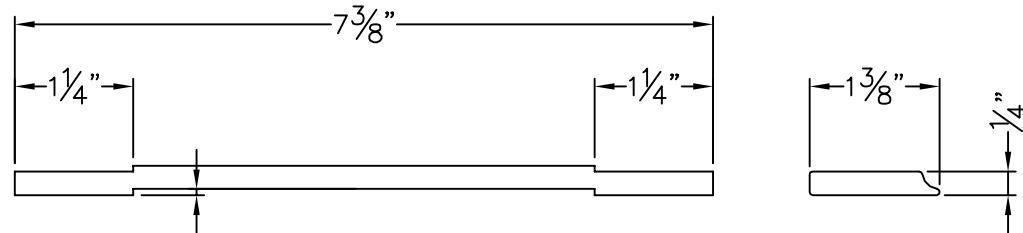

ITEM 31 - P1218
BUTT HINGE REINFORCEMENT

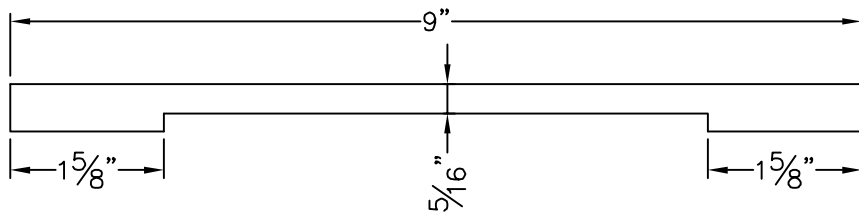

ITEM 43 - P0360
INTERMEDIATE PIVOT
REINFORCEMENT

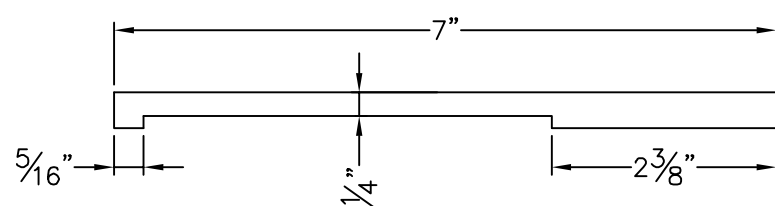

ITEM 55 TOP PIVOT
REINFORCEMENT

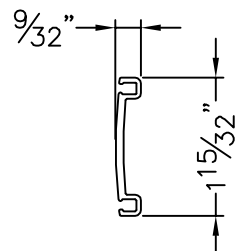

ITEM 10 - E1152
ASTRAGAL

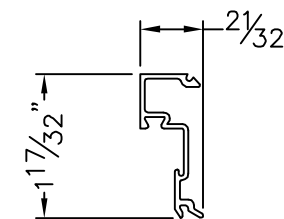

ITEM 11 - E0437
GLASS STOP

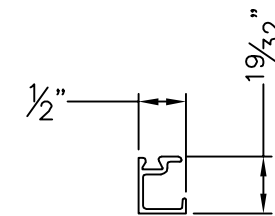

ITEM 12 - E0410
SNAP IN GLASS STOP

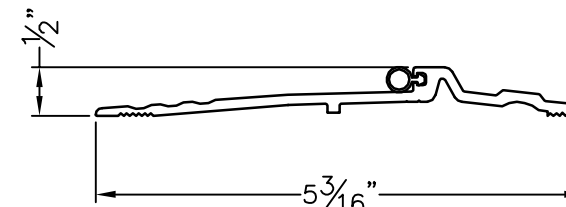

ITEM 20 - P6513-OR
THRESHOLD

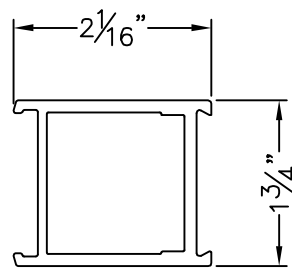

ITEM 9 - E1149
NARROW STILE LOCK W/ASTRAGAL

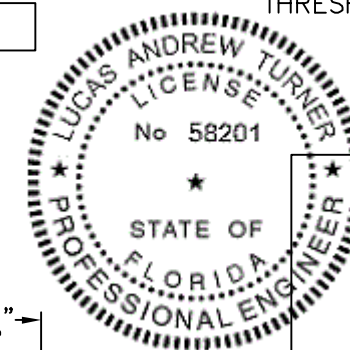

10/17/2017
LUCAS A. TURNER, P.E.
FL PE # 58201
TURNER ENGINEERING &
CONSULTING, INC.
(COA # 29779)
1239 JABARA AVE.
NORTH PORT, FL 34288
PH. 941-380-1574

TUBELITE
NARROW STILE
ENTRANCE DOOR

3056 WALKER RIDGE DRIVE N.W.
WALKER, MICHIGAN 49544
PH: 800.866.2227
FX: 916.301.0009
WEB SITE: WWW.TUBELITEINC.COM

TUBELITE
DEPENDABLE
LEADERS IN ECO-EFFICIENT STOREFRONT
CURTAINWALL AND ENTRANCE SYSTEMS

REVISION HISTORY:

REV	DATE	DRAWN	DESCRIPTION
0	3.4.14	LT	ORIGINAL RELEASE
A	10.17.17	LT	UPDATED HARDWARE

DATE: 03.04.14

DRAWING NUMBER:
FPA-NAR-NI

DRAWN:

FINAL REVIEW:

SCALE: N.T.S.

REVISION: A

SHEET NAME:

PROFILE
DRAWINGS

SHEET: 5 OF 6

PARTS LIST		MATERIAL	
ITEM	PART NUMBER	DESCRIPTION	
1A	E4544	EXTRUSION ~ OPEN BACK DOOR JAMB	ALUMINUM-6063-T5
1B	E14144	EXTRUSION ~ OPEN BACK DOOR JAMB	ALUMINUM-6063-T5
2A	E45124	EXTRUSION ~ DOOR HEADER	ALUMINUM-6063-T5
2B	E14124	EXTRUSION ~ DOOR HEADER	ALUMINUM-6063-T5
3	E4543	EXTRUSION ~ FLAT CLOSURE	ALUMINUM-6063-T5
4	E4531	EXTRUSION ~ DOOR STOP	ALUMINUM-6063-T5
5	E0054	EXTRUSION ~ BOTTOM RAIL	ALUMINUM-6063-T5
6	E1375	EXTRUSION ~ NARROW STILE TOP RAIL	ALUMINUM-6063-T5
7	E0055	EXTRUSION ~ NARROW STILE BUTT HINGE	ALUMINUM-6063-T5
8	E0056	EXTRUSION ~ NARROW STILE ROUND FACE STILE	ALUMINUM-6063-T5
9	E1149	EXTRUSION ~ NARROW STILE LOCK W/ASTRAGAL	ALUMINUM-6063-T5
10	E1152	EXTRUSION ~ ASTRAGAL	ALUMINUM-6063-T5
11	E0437	EXTRUSION ~ GLASS STOP	ALUMINUM-6063-T5
12	E0410	EXTRUSION ~ SNAP IN GLASS STOP	ALUMINUM-6063-T5
14	E0998	DOOR LUG (E0998)	RAILS TO STILES ALUMINUM-6063-T5
15	S071	3/8-16 HEX NUT W/LOCK WASHER	RAILS TO STILES P-PART FASTENER
16	NA	DOOR ROD WASHER	RAILS TO STILES ALUMINUM-6063-T5
17	NA	3/8-16 THREADED ROD	RAILS TO STILES P-PART FASTENER
20	P6513-OR	EXTRUSION ~ THRESHOLD W/GASKET (NGP PRODUCTS 896-96)	ALUMINUM-6063-T5
21	P1098A	PILE ~ DOOR STOP, AMESBURY GROUP	P-PART-PLASTIC FABRIC
22	P938	PILE ~ WOOL PILE FOR ADJUSTABLE ASTRAGEL SCHLEGE PILE WEATHERING #364-1006-5101	P-PART-PLASTIC FABRIC
23	P0017	GLAZING GASKET (TREMCO P/N 00218047E6Z)	P-PART-RUBBER
24	P0484	SETTING BLOCK (WL MOLDING CO #WL5389N)	P-PART-RUBBER
30	P1558 NRP	BUTT HINGE HAGAR BB-1199	P-PART-HARDWARE
31	P1218	BUTT HINGE REINFORCEMENT (DOOR FRAME & STILES)	P-PART-HARDWARE
35	P518	DOOR LABEL, GREEN BRUSHED SILVER	P-PART-LABEL
36	P1539	SPRING STEEL ASTRAGAL, ADJUSTABLE DOOR	P-PART-HARDWARE
37	P6563	SELECT 27HD CONTINUOUS HINGE	P-PART-HARDWARE
38	P695A	HINGE TOP FRAME OFFSET PIVOT RIXON 180	P-PART-HARDWARE
39	P695B	HINGE TOP DOOR OFFSET PIVOT RIXON 180	P-PART-HARDWARE
40	P695C	HINGE BOTTOM DOOR OFFSET PIVOT RIXON 147	P-PART-HARDWARE
41	P695	HINGE FLOOR OFFSET PIVOT RIXON 147	P-PART-HARDWARE
42	P751	HINGE INTERMEDIATE OFFSET PIVOT RIXON M19L	P-PART-HARDWARE
43	P0360	INTERMEDIATE PIVOT REINFORCEMENT	P-PART-HARDWARE
44	P1558 NRP	BUTT HINGE HAGAR BB-1199	P-PART-HARDWARE
47	P518	DOOR LABEL, GREEN BRUSHED SILVER	P-PART-LABEL
48	P1539	SPRING STEEL ASTRAGAL, ADJUSTABLE DOOR	P-PART-HARDWARE
49	P1553	WASHER, SCREW AND SHOULDER SCREW	P-PART-HARDWARE

ITEM	PART NUMBER	DESCRIPTION	
55	NA	EXTRUSION ~ TOP HINGE REINFORCEMENT	ALUMINUM-6063-T5
60	BY OTHERS	SCREW ~ INSTALL - SEE TABLE 1, SHEET 3 (FR. SUBSTRATE)	P-PART-FASTENER
61	S6504	SCREW ~ #6-32 x 1" FT HD PHIL TYPE F (GLASS STOP/DR STOP)	P-PART-FASTENER
62	S055	SCREW ~ #13 x 3" FLAT HD PHIL (THRESHOLD TO WOOD)	P-PART-FASTENER
63	S161	SCREW ~ #10-24 x 1/2 FLAT HD PHIL (DOOR HINGE/FLUSH BOLTS)	P-PART-FASTENER
64	S070	SCREW ~ #10-24 x 1/2 FLAT HD PHIL (FRAME HINGE)	P-PART-FASTENER
65	S341	SCREW ~ #10-24 x 3/4 FLAT HD PHIL (ASTRAGAL)	P-PART-FASTENER
66	S202	SCREW ~ #10 x 3/4" SELF TAPPING HPH (FRAME)	P-PART-FASTENER
67		SCREW ~ #1/4-20 x 1 1/2" FLAT HD PHIL (OFFSET HINGE)	P-PART-FASTENER
68		SCREW ~ #1/4-20 x 5/8" FLAT HD PHIL (OFFSET REINFORCEMENT)	P-PART-FASTENER
69		SCREW ~ #1/4-20 x 1 1/2" FLAT HD PHIL SMS	P-PART-FASTENER
71		SCREW ~ #12-24 x 7/8 SELF TAPPING FH PHIL (CONTINUOUS HINGE)	P-PART-FASTENER
73	P6527-C2	P6527-C2 PULL (ROCKWOOD)	P-PART-HARDWARE
74	P1564-C2	P1564-C2 PULL (ROCKWOOD)	P-PART-HARDWARE
75	NA	LOCK CVR-FALCON HSEC 1690	P-PART-HARDWARE
76	NA	LOCK SARGENT MD8600	P-PART-HARDWARE
78	NA	2086-47 X 96 CVR PANIC FIN-628 LHR (JACKSON)	P-PART-HARDWARE
80	NA	G86 (ADAMS RITE)	P-PART-HARDWARE
82	NA	30-1084 TOP & BOTTOM STRIKE (JACKSON)	P-PART-HARDWARE
83	NA	30-821J CYLINDER KIT FIN -628 RHR (JACKSON)	P-PART-HARDWARE
85	P1010-OR	P1010-OR TWO POINT THOLD BOLT (ADAMS RITE)	P-PART-HARDWARE
87	NA	8659 CYLINDER ESCUCHEON (ADAMS RITE)	P-PART-HARDWARE
89	P1010-OR	P1010-OR TWO POINT THOLD BOLT (ADAMS RITE)	P-PART-HARDWARE
90	P6508-OR	P6508-OR DEADLOCK BODY ONLY 1 1/2 BS (ADAMS RITE)	P-PART-HARDWARE
91	P6509-OR	P6509-OR HEADER BOLT 1 1/2 BACKSET (ADAMS RITE)	P-PART-HARDWARE
92	NA	MS1881-36"-96" TWO POINT FLUSH BOLT (ADAMS RITE)	P-PART-HARDWARE
93	P572-C2	P572-C2 PAIR MORTISE CYLINDER (RYADON)	P-PART-HARDWARE
94	P1825-C2	P1825-C2 SPLIT RING CYLINDER COLLAR (RYADON)	P-PART-HARDWARE
96	NA	8659 CYLINDER ESCUTCHEON (ADAMS RITE)	P-PART-HARDWARE
97	P6510	BF15747-44 PUSH PULL SET (ROCKWOOD)	P-PART-HARDWARE

TUBELITE
NARROW STILE
ENTRANCE DOOR

3056 WALKER RIDGE DRIVE N.W.
WALKER, MICHIGAN 49544
PH: 800.866.2227
FX: 96.301.0000
WEB SITE: WWW.TUBELITEINC.COM

TUBELITE
DEPENDABLE
LEADERS IN ECO-EFFICIENT STOREFRONT
CURTAINWALL AND ENTRANCE SYSTEMS

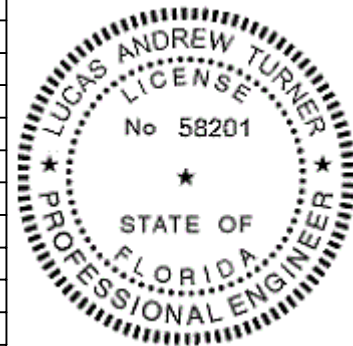

REVISION HISTORY:

REV	DATE	DESCRIPTION
0	3.4.14	ORIGINAL RELEASE
A	10.17.17	UPDATED HARDWARE

DATE: 03.04.14

DRAWING NUMBER: FPA-NAR-NI

DRAWN:

FINAL REVIEW:

SCALE: N.T.S.

REVISION: A

SHEET NAME:

BILL OF MATERIALS

SHEET: 6 OF 6

22
10/17/2017
LUCAS A. TURNER, P.E.
FL PE # 58201
TURNER ENGINEERING &
CONSULTING, INC.
(COA # 29779)
1239 JABARA AVE.
NORTH PORT, FL 34288
PH. 941-380-1574