

REVISIONS			
REV	DESCRIPTION	DATE	APPROVED
A	REVISED PER NEW REQUIREMENTS	01/05/18	R.L.

NOTES:

1. THE PRODUCT SHOWN HEREIN IS DESIGNED AND MANUFACTURED TO COMPLY WITH REQUIREMENTS OF THE FLORIDA BUILDING CODE INCLUDING THE HVHZ.
2. WOOD FRAMING AND MASONRY OPENING TO BE DESIGNED AND ANCHORED TO PROPERLY TRANSFER ALL LOADS TO STRUCTURE. FRAMING AND MASONRY OPENING IS THE RESPONSIBILITY OF THE ARCHITECT OR ENGINEER OF RECORD.
3. 1X BUCK OVER MASONRY/CONCRETE IS OPTIONAL.
4. WHERE SHIM OR BUCK THICKNESS IS LESS THAN 1-1/2" WINDOW UNITS MUST BE ANCHORED THROUGH THE FRAME IN ACCORDANCE WITH MANUFACTURER'S PUBLISHED INSTALLATION INSTRUCTIONS. ANCHORS SHALL BE SECURELY FASTENED DIRECTLY INTO MASONRY, CONCRETE OR OTHER STRUCTURAL SUBSTRATE MATERIAL.
5. WHERE WOOD BUCK THICKNESS IS 1-1/2" OR GREATER, BUCK SHALL BE SECURELY FASTENED TO MASONRY, CONCRETE OR OTHER STRUCTURAL SUBSTRATE. WINDOW UNITS MAY BE ANCHORED THROUGH FRAME TO SECURED WOOD BUCK IN ACCORDANCE WITH MANUFACTURER'S PUBLISHED INSTALLATION INSTRUCTIONS.
6. WHERE 1X BUCK IS NOT USED DISSIMILAR MATERIALS MUST BE SEPARATED WITH APPROVED COATING OR MEMBRANE. SELECTION OF COATING OR MEMBRANE IS THE RESPONSIBILITY OF THE ARCHITECT OR ENGINEER OF RECORD.
7. BUCKS SHALL EXTEND BEYOND WINDOW INTERIOR FACE SO THAT FULL FRAME SUPPORT IS PROVIDED.
8. SHIM AS REQUIRED AT EACH ANCHOR LOCATION WITH LOAD BEARING SHIM. SHIM WHERE SPACE OF 1/16" OR GREATER OCCURS. MAXIMUM ALLOWABLE SHIM STACK TO BE 1/4".
9. SHIMS SHALL BE LOCATED, APPLIED AND MADE FROM MATERIALS AND THICKNESS CAPABLE OF SUSTAINING APPLICABLE LOADS.
10. WIND LOAD DURATION FACTOR Cd=1.6 WAS USED FOR WOOD ANCHOR CALCULATIONS.
11. FRAME MATERIAL: EXTRUDED ALUMINUM 6063-T5.
12. UNITS MUST BE GLAZED PER ASTM E1300-04/09, SEE SHEET 3 FOR GLASS DETAILS.
13. APPROVED IMPACT PROTECTIVE SYSTEM IS NOT REQUIRED FOR THIS PRODUCT IN WIND BORNE DEBRIS REGIONS.
14. FOR ANCHORING THROUGH FRAME INTO WOOD FRAMING OR 2X BUCK USE #14 WOOD SCREWS WITH SUFFICIENT LENGTH TO ACHIEVE A 1 7/16" MINIMUM EMBEDMENT INTO SUBSTRATE. LOCATE ANCHORS AS SHOWN IN ELEVATIONS AND INSTALLATION DETAILS.

15. FOR ANCHORING THROUGH FRAME INTO MASONRY/CONCRETE USE 1/4 ELCO CRETE-FLEX TAPCONS WITH SUFFICIENT LENGTH TO ACHIEVE A 1 1/4" MINIMUM EMBEDMENT INTO SUBSTRATE WITH 2" MINIMUM EDGE DISTANCE. LOCATE ANCHORS AS SHOWN IN ELEVATIONS AND INSTALLATION DETAILS.
16. FOR ANCHORING THROUGH FRAME INTO METAL STRUCTURE USE #14 SMS OR SELF DRILLING SCREWS WITH SUFFICIENT LENGTH TO ACHIEVE 3 THREADS MINIMUM BEYOND STRUCTURE INTERIOR WALL. LOCATE ANCHORS AS SHOWN IN ELEVATIONS AND INSTALLATION DETAILS.
17. ALL FASTENERS TO BE CORROSION RESISTANT.
18. INSTALLATION ANCHORS SHALL BE INSTALLED IN ACCORDANCE WITH ANCHOR MANUFACTURER'S INSTALLATION INSTRUCTIONS AND ANCHORS SHALL NOT BE USED IN SUBSTRATES WITH STRENGTHS LESS THAN THE MINIMUM STRENGTH SPECIFIED BELOW:
 - A. WOOD - MINIMUM SPECIFIC GRAVITY OF G=0.42
 - B. CONCRETE - MINIMUM COMPRESSIVE STRENGTH OF 3,192 PSI.
 - C. MASONRY - STRENGTH CONFORMANCE TO ASTM C-90, GRADE N, TYPE 1 (OR GREATER).
 - D. METAL STRUCTURE: STEEL 18GA, 33KSI OR ALUMINUM 6063-T5 .052" THICK MINIMUM
19. APPROVED CONFIGURATIONS: OX, XO.

SIGNED: 01/05/2018

TABLE OF CONTENTS	
SHEET NO.	DESCRIPTION
1	NOTES
2	ELEVATION & GLAZING DETAIL
3 - 5	INSTALLATION DETAILS

 Eastern ARCHITECTURAL SYSTEMS ALUMINUM AND VINYL IMPACT WINDOWS AND DOORS		EASTERN ARCHITECTURAL SYSTEMS A DIVISION OF EASTERN METAL SUPPLY 10030 BAVARIA ROAD FORT MYERS, FLORIDA 33913 800-432-2204	
SERIES FWI 1000 ALUMINUM, IMPACT HORIZONTAL SLIDING WINDOW 74 1/8" X 63" NOTES			
DRAWN: V.L.	DWG NO. 08-02679	REV A	
SCALE NTS	DATE 04/13/15	SHEET 1 OF 5	
L. ROBERTO LOMAS P.E. 1432 WOODFORD RD LEWISVILLE, NC 27023 434-688-0609 rllomas@rlomaspe.com			

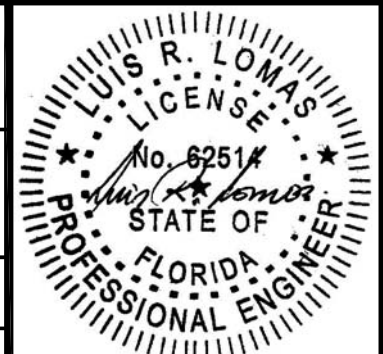

Luis R. Lomas P.E.
FL No.: 62514

REVISIONS			
REV	DESCRIPTION	DATE	APPROVED
A	REVISED PER NEW REQUIREMENTS	01/05/18	R.L.

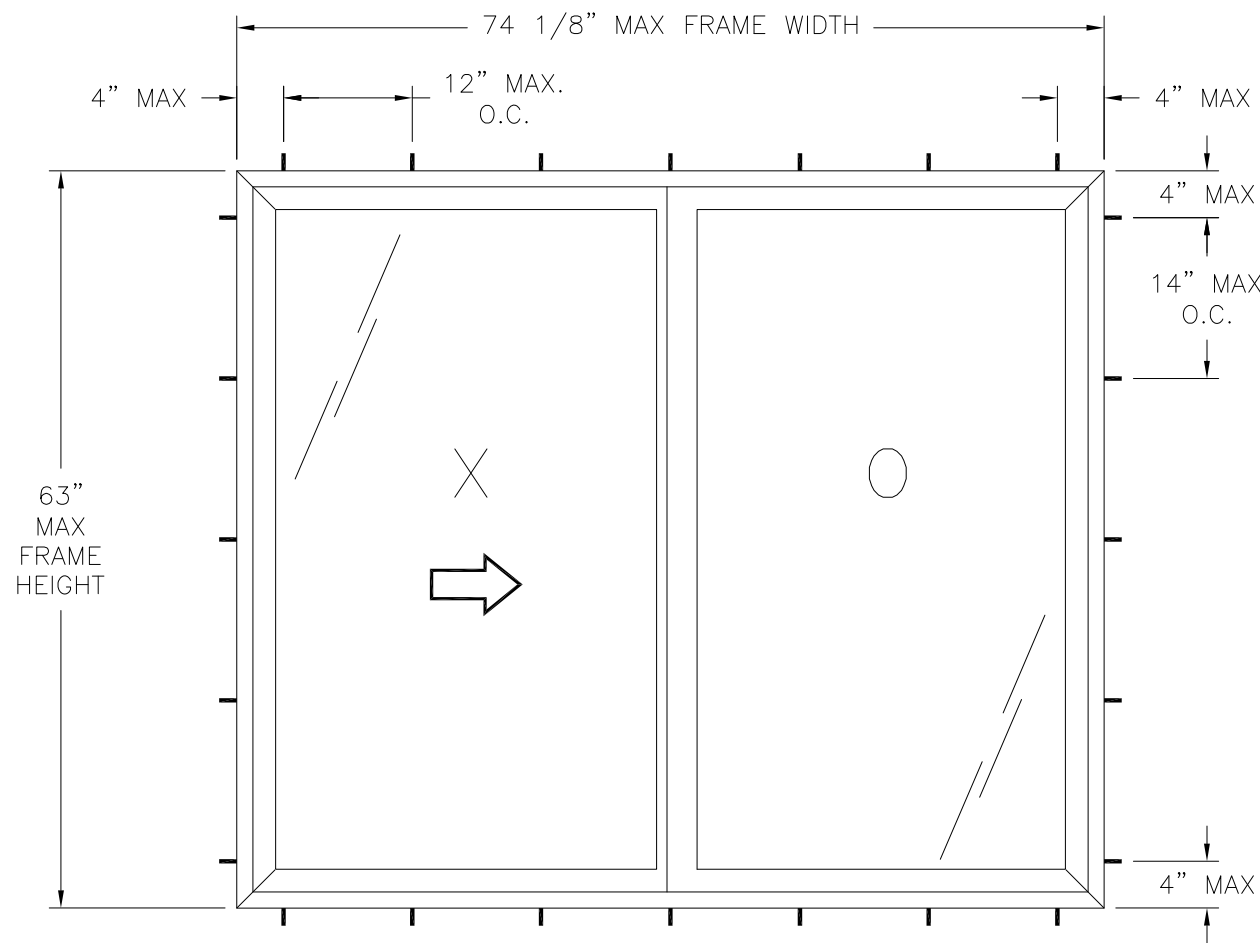

SERIES FWI 1000 ALUMINUM HORIZONTAL SLIDING WINDOW
EXTERIOR VIEW FRAME

DESIGN PRESSURE RATING	IMPACT RATING
+100.0/-120.0PSF	LARGE AND SMALL MISSILE IMPACT

MISSILE LEVEL D, WIND ZONE 4, AND HVHZ

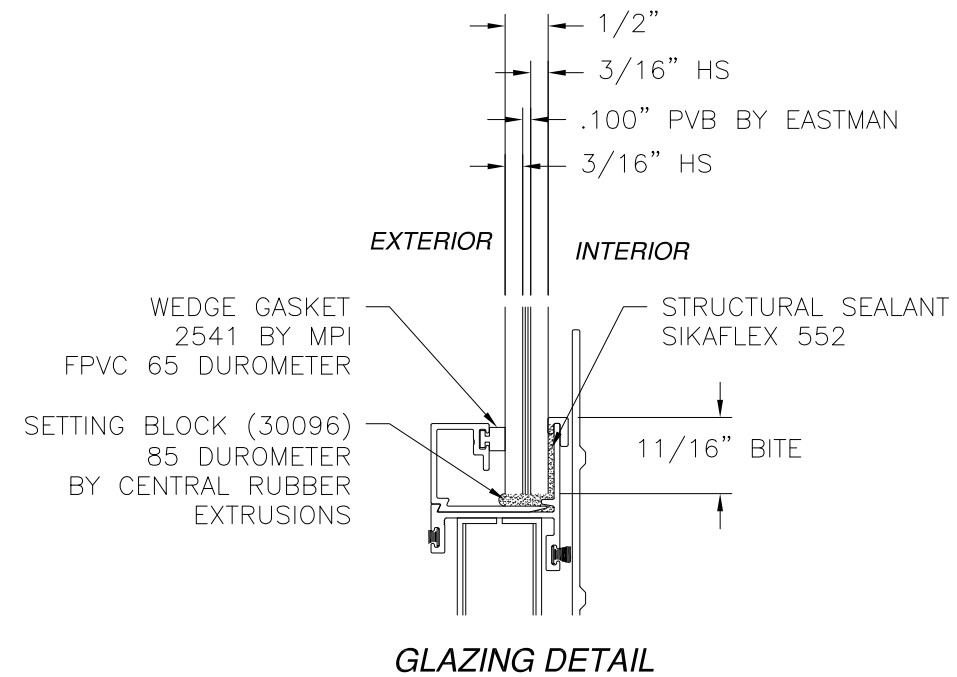

- NOTES:
- SASH SIZE: 36 1/2" X 61"
 - MAXIMUM D.L.O.: 32 5/8" X 56"
 - (2) 1 1/4" X 3/8" WEEPHOLES AT FRAME SILL 4 1/2" FROM EACH END.

HARDWARE SCHEDULE

A.	(2) SURFACE MOUNT ALUMINUM CAM LOCK AT MEETING RAIL, 18" FROM TOM & BOTTOM
B.	(2) TANDEMBRASS WHEELS IN PLASTIC HOUSING AT VENT BOTTOM RAIL, 1/4" FROM EACH END

SIGNED: 01/05/2018

		EASTERN ARCHITECTURAL SYSTEMS A DIVISION OF EASTERN METAL SUPPLY 10030 BAVARIA ROAD FORT MYERS, FLORIDA 33913 800-432-2204	
SERIES FWI 1000 ALUMINUM, IMPACT HORIZONTAL SLIDING WINDOW 74 1/8" X 63" ELEVATION AND GLAZING DETAIL			
DRAWN: V.L.	DWG NO. 08-02679	REV A	
SCALE NTS	DATE 04/13/15	SHEET 2 OF 5	
L. ROBERTO LOMAS P.E. 1432 WOODFORD RD LEWISVILLE, NC 27023 434-688-0609 rllomas@rlomaspe.com			

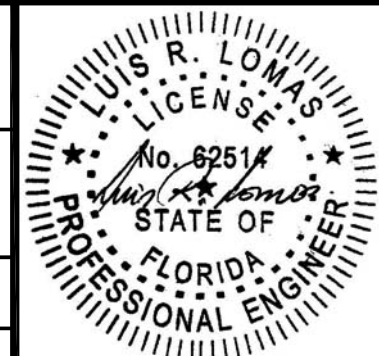

Luis R. Lomas P.E.
FL No.: 62514

REVISIONS			
REV	DESCRIPTION	DATE	APPROVED
A	REVISED PER NEW REQUIREMENTS	01/05/18	R.L.

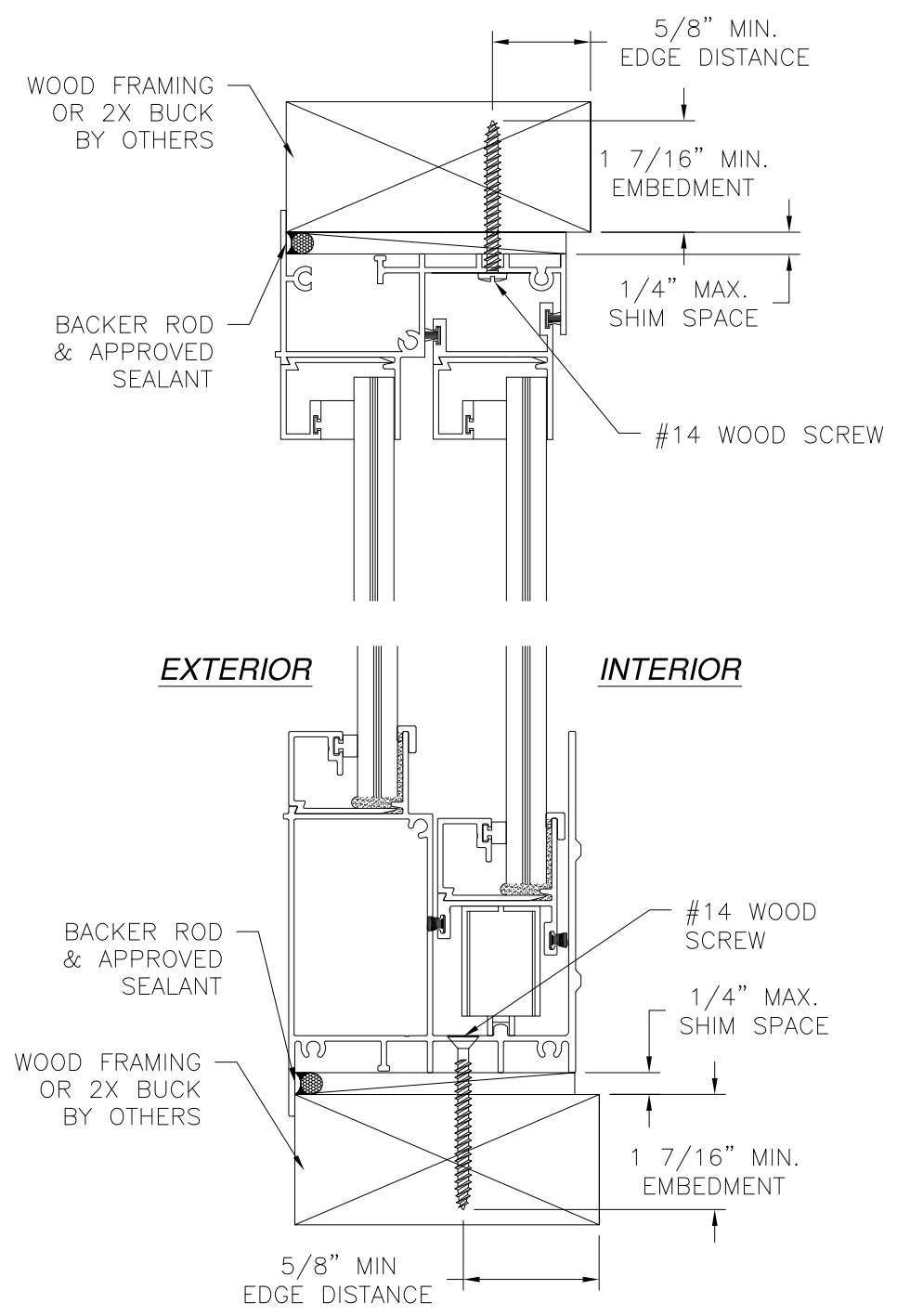

VERTICAL CROSS SECTION
WOOD FRAMING OR 2X BUCK INSTALLATION

NOTES:
 1. INTERIOR AND EXTERIOR FINISHES, BY OTHERS, NOT SHOWN FOR CLARITY.
 2. PERIMETER AND JOINT SEALANT BY OTHERS TO BE DESIGNED IN ACCORDANCE WITH ASTM E2112

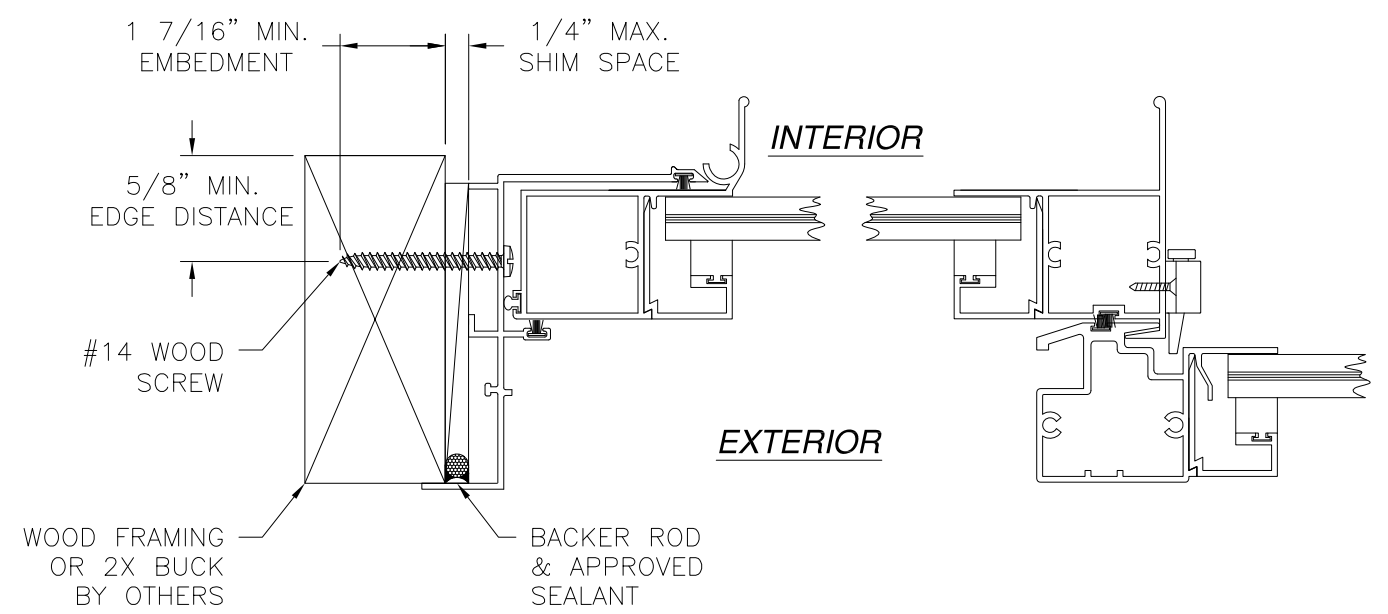

JAMB INSTALLATION DETAIL
WOOD FRAMING OR 2X BUCK INSTALLATION

		EASTERN ARCHITECTURAL SYSTEMS A DIVISION OF EASTERN METAL SUPPLY 10030 BAVARIA ROAD FORT MYERS, FLORIDA 33913 800-432-2204	
SERIES FWI 1000 ALUMINUM, IMPACT HORIZONTAL SLIDING WINDOW 74 1/8" X 63" INSTALLATION DETAILS			
DRAWN: V.L.	DWG NO. 08-02679	REV A	
SCALE NTS	DATE 04/13/15	SHEET 3 OF 5	
L. ROBERTO LOMAS P.E. 1432 WOODFORD RD LEWISVILLE, NC 27023 434-688-0609 rllomas@rlomaspe.com			

SIGNED: 01/05/2018

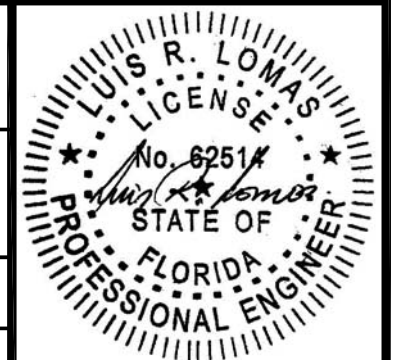

Luis R. Lomas P.E.
FL No.: 62514

REVISIONS			
REV	DESCRIPTION	DATE	APPROVED
A	REVISED PER NEW REQUIREMENTS	01/05/18	R.L.

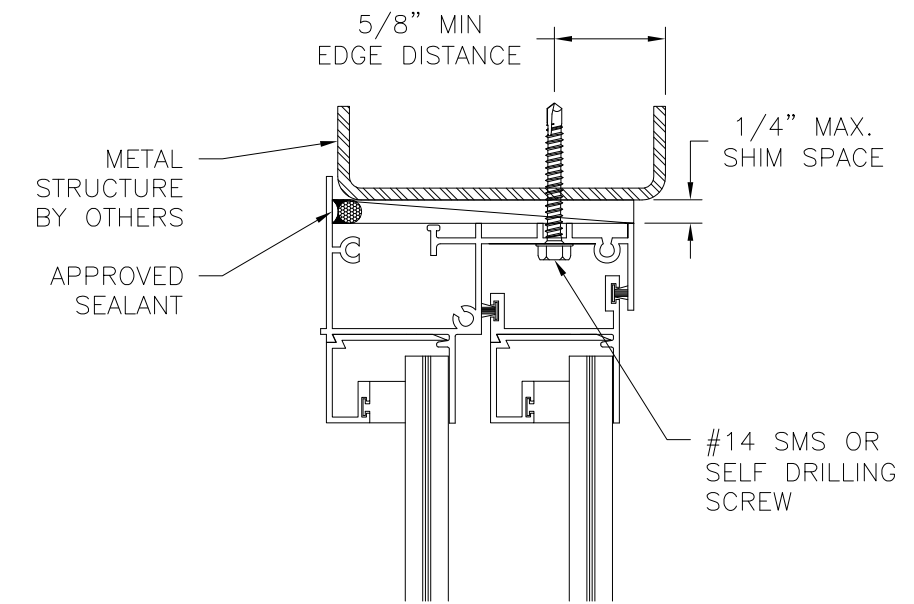

EXTERIOR **INTERIOR**

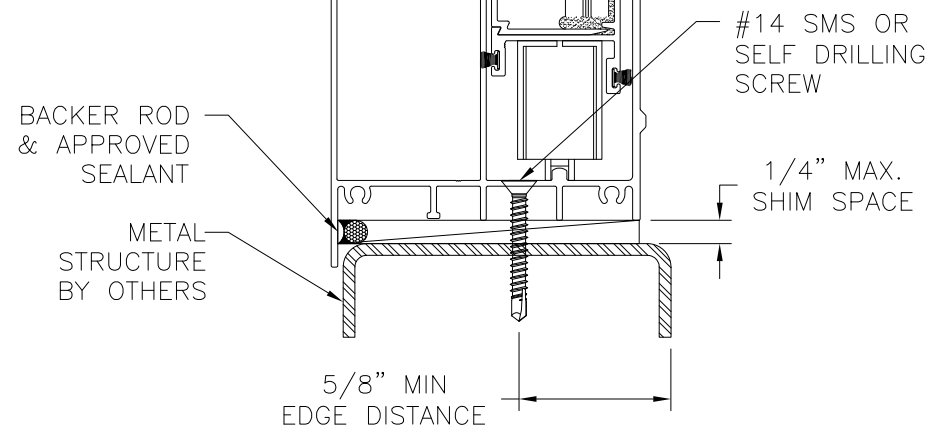

VERTICAL CROSS SECTION
METAL STRUCTURE INSTALLATION

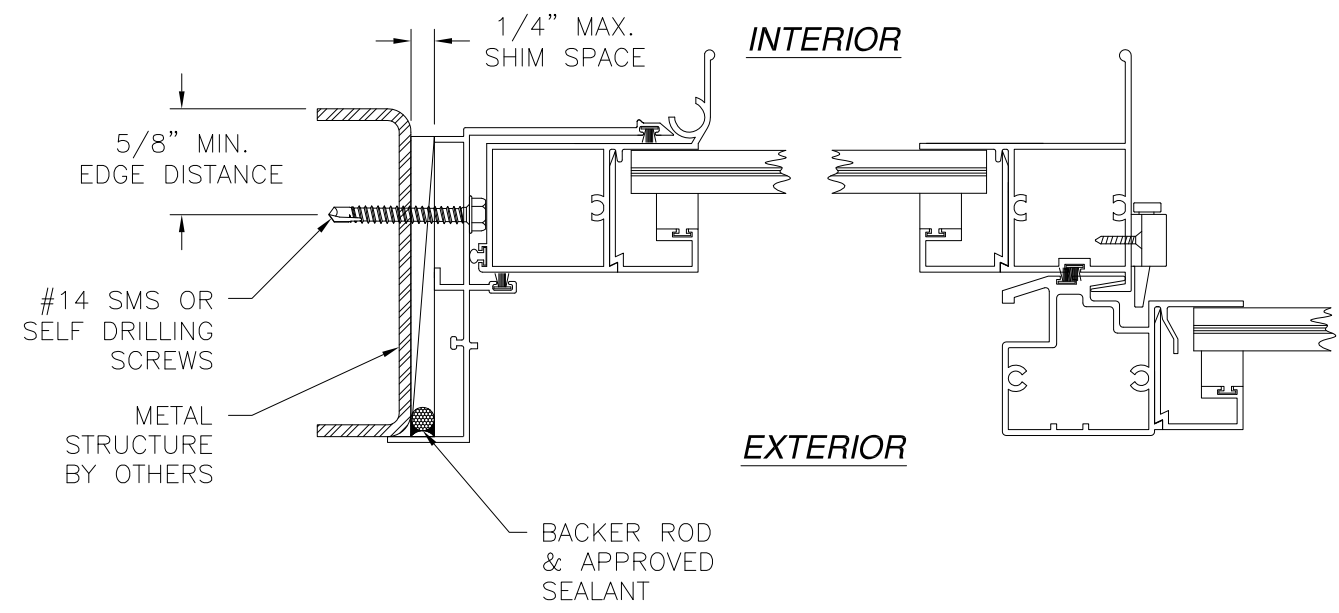

JAMB INSTALLATION DETAIL
METAL STRUCTURE INSTALLATION

NOTES:
 1. INTERIOR AND EXTERIOR FINISHES, BY OTHERS, NOT SHOWN FOR CLARITY.
 2. PERIMETER AND JOINT SEALANT BY OTHERS TO BE DESIGNED IN ACCORDANCE WITH ASTM E2112

		EASTERN ARCHITECTURAL SYSTEMS A DIVISION OF EASTERN METAL SUPPLY	
10030 BAVARIA ROAD FORT MYERS, FLORIDA 33913 800-432-2204		SERIES FWI 1000 ALUMINUM, IMPACT HORIZONTAL SLIDING WINDOW 74 1/8" X 63" INSTALLATION DETAILS	
DRAWN: V.L.	DWG NO. 08-02679	REV A	
SCALE NTS	DATE 04/13/15	SHEET 4 OF 5	
L. ROBERTO LOMAS P.E. 1432 WOODFORD RD LEWISVILLE, NC 27023 434-688-0609 rllomas@rlomaspe.com			

SIGNED: 01/05/2018

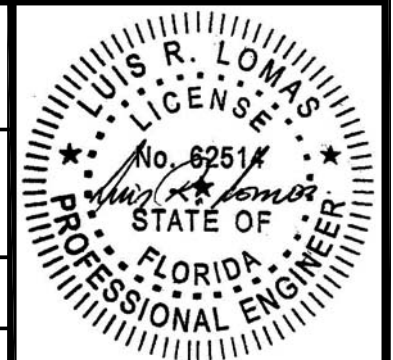

Luis R. Lomas P.E.
FL No.: 62514

REVISIONS			
REV	DESCRIPTION	DATE	APPROVED
A	REVISED PER NEW REQUIREMENTS	01/05/18	R.L.

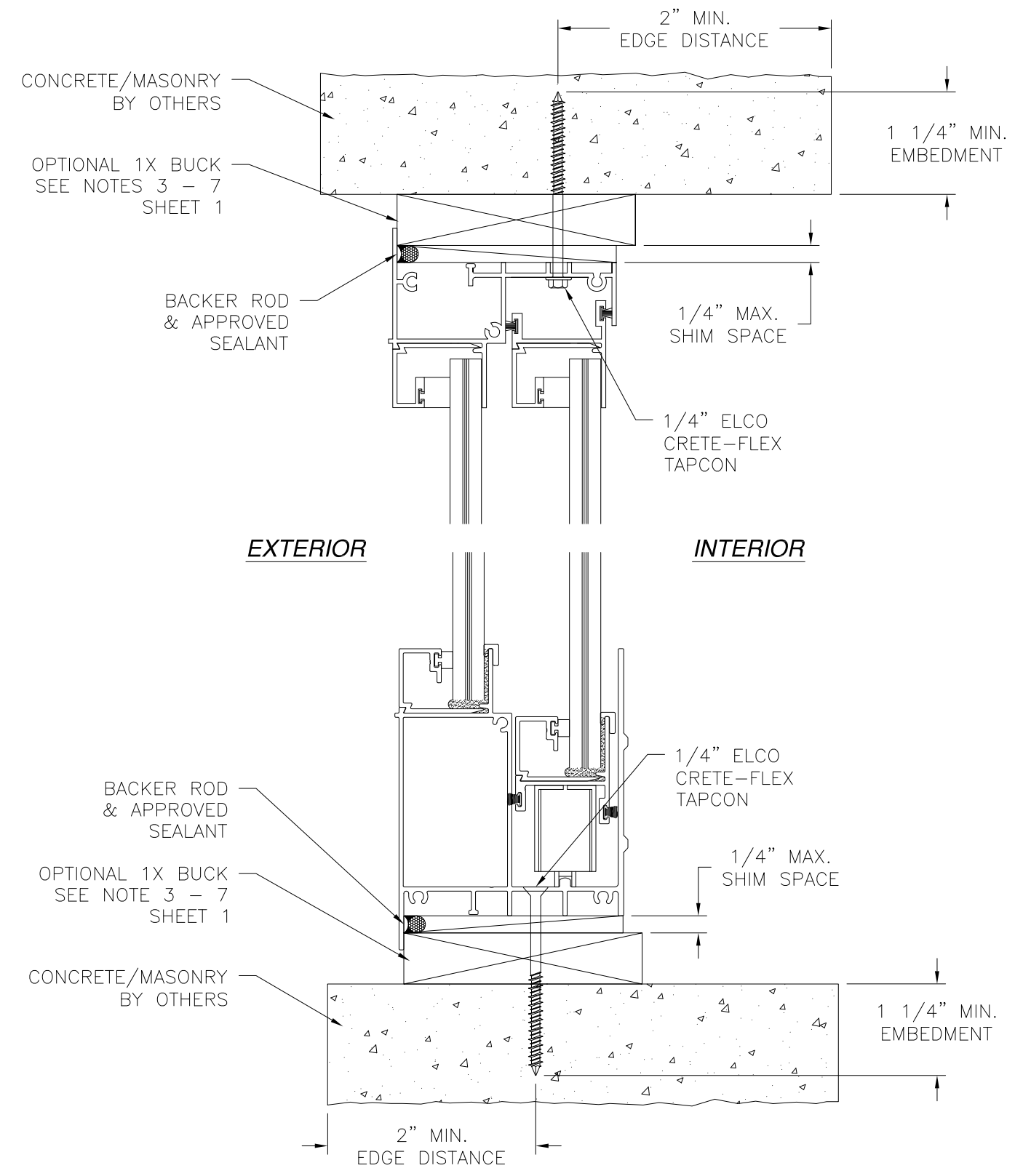

**VERTICAL CROSS SECTION
CONCRETE/MASONRY INSTALLATION**

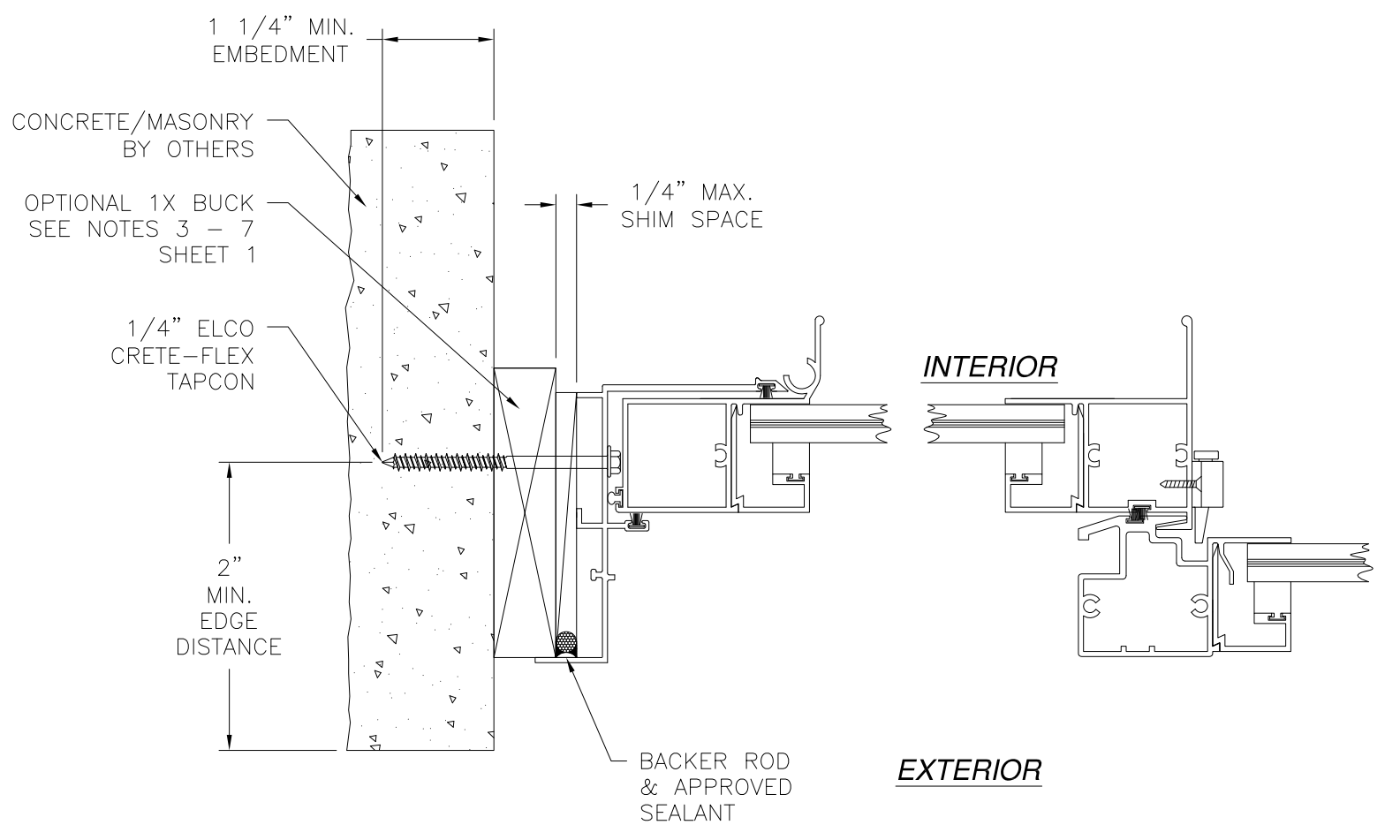

**JAMB INSTALLATION DETAIL
CONCRETE/MASONRY INSTALLATION**

NOTES:
 1. INTERIOR AND EXTERIOR FINISHES, BY OTHERS, NOT SHOWN FOR CLARITY.
 2. PERIMETER AND JOINT SEALANT BY OTHERS TO BE DESIGNED IN ACCORDANCE WITH ASTM E2112

 Eastern ARCHITECTURAL SYSTEMS ALUMINUM AND VINYL IMPACT WINDOWS AND DOORS		EASTERN ARCHITECTURAL SYSTEMS A DIVISION OF EASTERN METAL SUPPLY 10030 BAVARIA ROAD FORT MYERS, FLORIDA 33913 800-432-2204	
SERIES FWI 1000 ALUMINUM, IMPACT HORIZONTAL SLIDING WINDOW 74 1/8" X 63" INSTALLATION DETAILS			
DRAWN: V.L.	DWG. NO. 08-02679	REV A	
SCALE NTS	DATE 04/13/15	SHEET 5 OF 5	
L. ROBERTO LOMAS P.E. 1432 WOODFORD RD LEWISVILLE, NC 27023 434-688-0609 rllomas@rlomaspe.com			

SIGNED: 01/05/2018

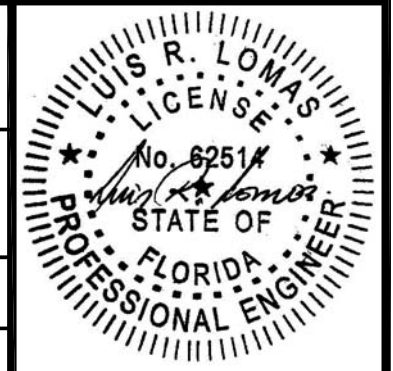

Luis R. Lomas P.E.
 FL No.: 62514