

**GENERAL NOTES:**

1. THIS PRODUCT, FABRICATED AND ANCHORED AS DETAILED IN THIS DRAWING, IS LARGE MISSILE IMPACT RESISTANT (HVHZ AND WIND ZONE 4 MISSILE LEVEL D) AND DOES NOT REQUIRE THE USE OF SHUTTERS.
2. THIS PRODUCT HAS BEEN TESTED TO TAS 201-94, TAS 202-94, TAS 203-94, ASTM E 283, ASTM E 330, ASTM E 1886/1996, AND AAMA 1304, AND MEETS THE REQUIREMENTS OF THE FLORIDA BUILDING CODE, 6TH EDITION (2017), INCLUDING THE HIGH VELOCITY HURRICANE ZONE. THIS PRODUCT IS NOT RATED FOR WATER INFILTRATION RESISTANCE.
3. ALLOWABLE CONFIGURATIONS: X (SINGLE PANEL), X-X (DOUBLE PANEL). PANELS MAY BE INSTALLED INTO APPROVED TUBELITE FRAMING (SEE SEPARATE APPROVALS), WITH THE LOWER OF THE DOOR OR FRAMING DESIGN PRESSURES APPLYING TO THE ENTIRE ASSEMBLY.
4. THE DESIGN PRESSURE RATINGS (SEE SHEETS 1 AND 2) IN THIS DRAWING ARE AS LIMITED BY ASTM E-1300 04E01/09 GLASS TABLES, AND TESTED PRESSURES.
5. THE 4/3 ALLOWABLE STRESS INCREASE HAS NOT BEEN USED IN THE ANCHOR ANALYSIS FOR THIS SYSTEM. THE 1.6 Cd FACTOR WAS USED IN THE ANALYSIS OF ANCHORAGE INTO WOOD SUBSTRATE.
6. INSTALLATION OF WOOD BUCKS TO THE SUBSTRATE TO BE ENGINEERED BY OTHERS OR AS APPROVED BY THE AUTHORITY HAVING JURISDICTION. BUCKING, OPENINGS & BUCKING FASTENERS MUST BE PROPERLY DESIGN & INSTALLED TO TRANSFER WIND LOADS TO THE STRUCTURE.
7. DISSIMILAR MATERIALS THAT COME INTO CONTACT SHALL BE COATED OR OTHERWISE PROTECTED PER FBC TO PREVENT GALVANIC REACTIONS.
8. ALL HARDWARE & FASTENERS SHALL BE IN ACCORDANCE WITH THESE DRAWINGS & MAY NOT VARY UNLESS SPECIFICALLY MENTIONED ON THE DRAWINGS.
9. SPECIFIED EMBEDMENT TO BASE MATERIAL SHALL BE BEYOND WALL FINISH OR STUCCO.
10. TUBELITE STANDARD MEDIUM STILE DOOR PANELS (SEE SEPARATE APPROVAL) MAY BE USED IN THIS FRAMING SYSTEM, WITH DESIGN PRESSURE LIMITED TO 50 PSF OR AS SHOWN IN MEDIUM STILE DOOR PRODUCT APPROVAL.

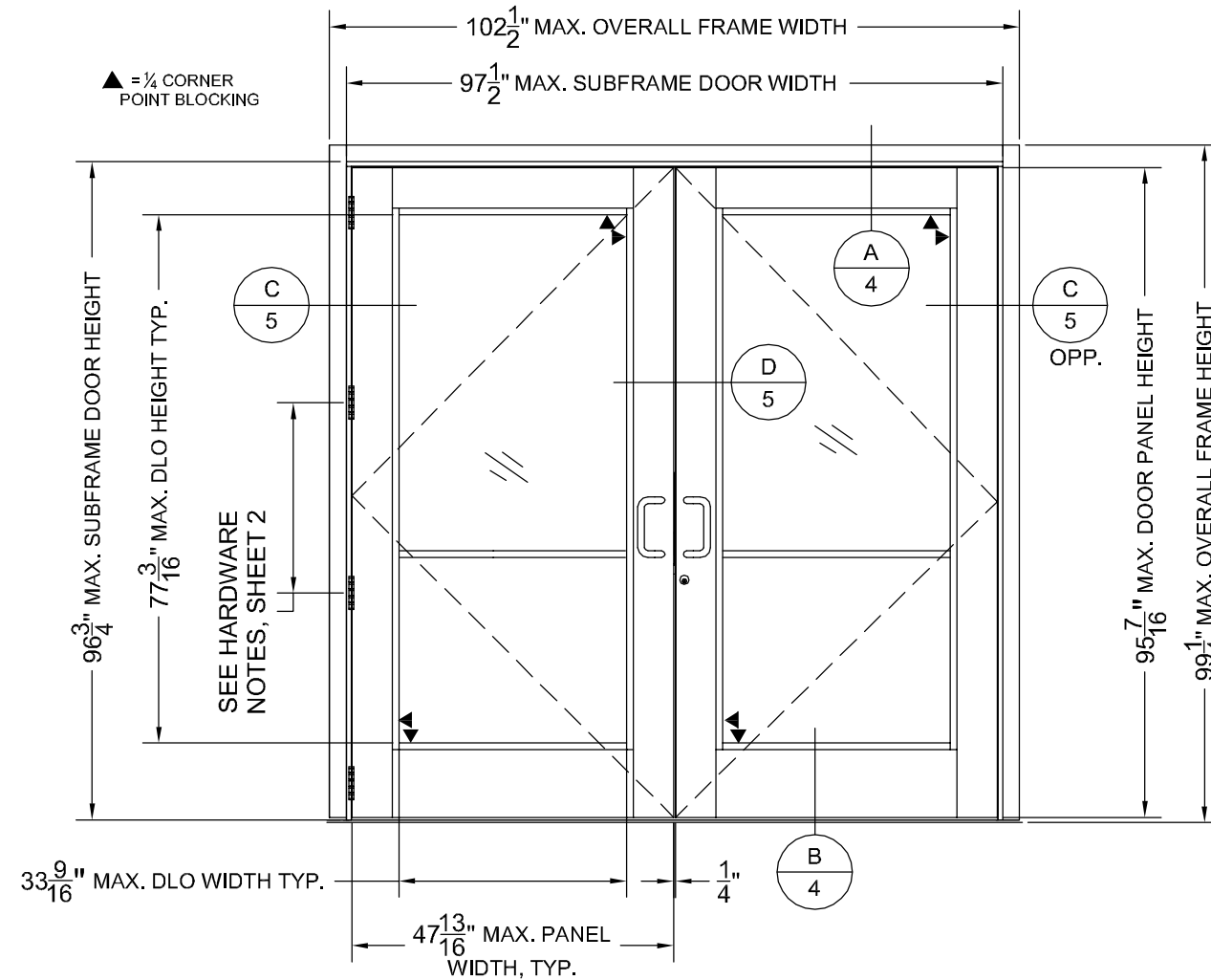

**ELEVATION A**

8-0 x 8-0 DOOR 3-POINT LOCK ACTIVE, FLUSH BOLTS INACTIVE

ELEVATION A			
QUALIFIED LOCKING HARDWARE	BOTTOM OF DOOR TO LOCK CENTERLINE	DESIGN PRESSURE RATING (+/-PSF)	IMPACT RATING
ACTIVE: ADAMS-RITE 1853A (DEADLOCK 3-POINT WITH FLUSH BOLTS MS1850S 1- 1/2 BACKSET, 4015 THRESHOLD BOLT AT BOTTOM OF PANEL, 4016 BOLT AT TOP OF PANEL)	35 1/2"	100	LARGE & SMALL MISSILE IMPACT
INACTIVE: ADAMS-RITE MS1881, MS2180, OR P1010-OR TWO POINT FLUSH BOLTS		130	NONE
ACTIVE: AS DESCRIBED ABOVE INACTIVE: INTERNATIONAL F1203 STANDARD FLUSH BOLTS, PART #P059 WITH #P849 GUIDE, ON TOP AND BOTTOM OF PANEL	35 1/2"	90	LARGE & SMALL MISSILE IMPACT

**TUBELITE, INC.**  
**MONUMENTAL ALUMINUM OUTSWING ENTRANCE DOOR IN CURTAIN WALL FRAME (LARGE MISSILE IMPACT)**

TUBELITE  
 FORCEFRONT  
 HURRICANE SERIES  
 MONUMENTAL DOORS - DRY SET  
 IN CURTAINWALL FRAME

3065 WALKER RIDGE DRIVE N.W.  
 WALKER, MICHIGAN 49544  
 PH: 800.866.2227  
 FX: 616.501.0008  
 WEB SITE: WWW.TUBELITEINC.COM

**TUBELITE**  
 DEPENDABLE  
 LEADERS IN ECO-EFFICIENT STOREFRONT CURTAINWALL AND ENTRANCE SYSTEMS

**TABLE OF CONTENTS:**

SHEET	DESCRIPTION
1	GEN. NOTES, ELEV. A
2	ELEV. B/C, HARDWARE NOTES
3	ANCHOR LOC. ELEVATION, INSTALLATION, GLAZING
4-5	SECTION DETAILS
6	BILL OF MATERIALS
7	PROFILE DRAWING

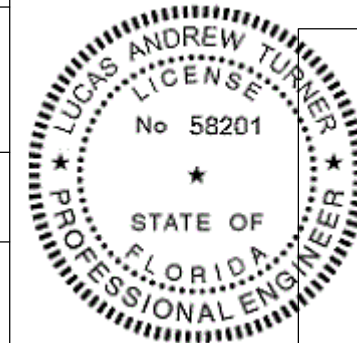

10/13/2017  
 LUCAS A. TURNER, P.E.  
 FL PE # 58201  
 TURNER ENGINEERING & CONSULTING, INC.  
 (COA # 29779)  
 1239 JABARA AVE.  
 NORTH PORT, FL 34288  
 PH. 941-380-1574

REVISION HISTORY:	
DESCRIPTION	DATE
ORIGINAL RELEASE	3.29.11
ADDED HARDWARE	8.29.11
REVISED FOR 2014 FBC	4.29.15
REVISED FOR 2017 FBC	10.12.17

  

DATE:	08.29.11
DRAWING NUMBER:	FPA-MON-HVHZ
DRAWN:	LT
FINAL REVIEW:	SW
SCALE:	N.T.S.
REVISION:	C
SHEET NAME:	GEN. NOTES, ELEVATION A
SHEET:	1 OF 7

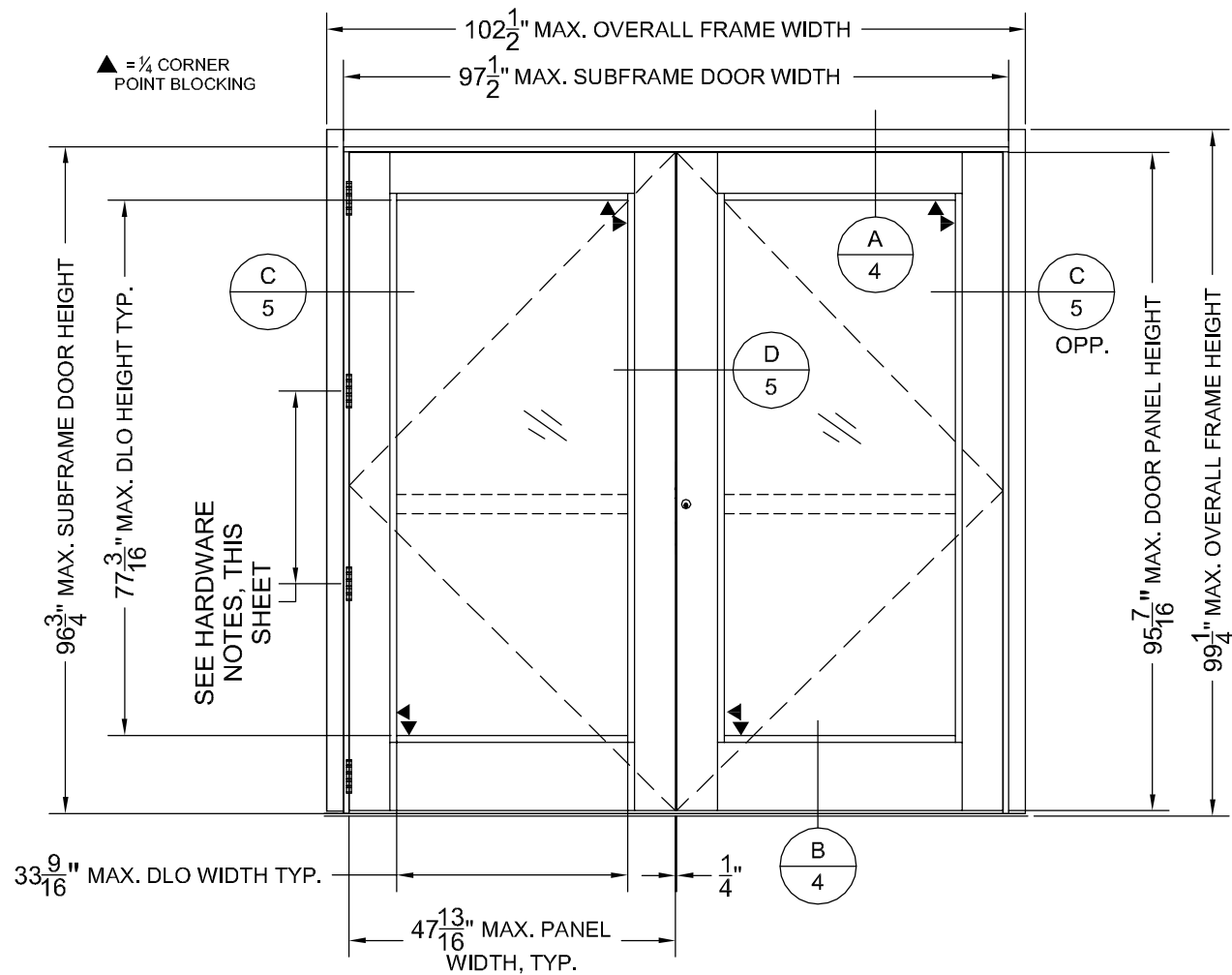

**ELEVATION B**

8-0 x 8-0 DOOR CONCEALED VERTICAL ROD / CABLE EXIT DEVICES

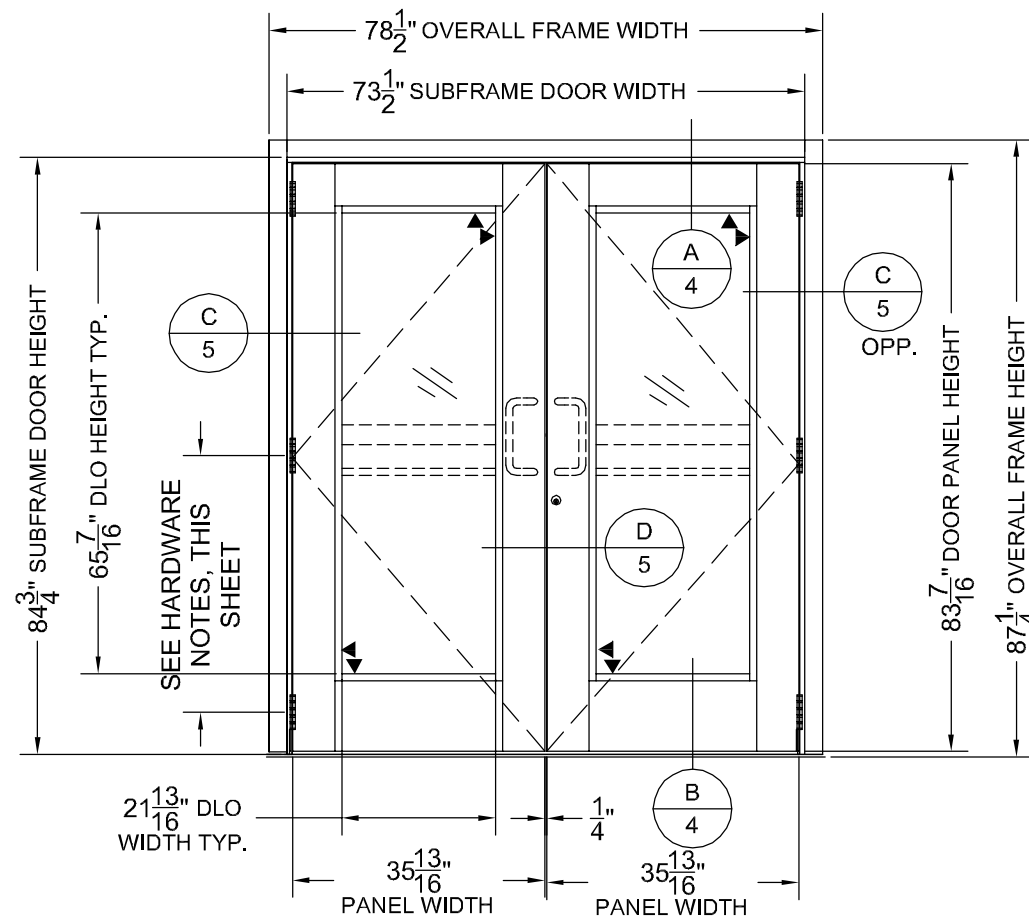

**ELEVATION C**

6-0 x 7-0 DOOR - CVR EXIT OR 3-POINT LOCKS

ELEVATION B			
QUALIFIED LOCKING HARDWARE	BOTTOM OF DOOR TO LOCK CENTERLINE	DESIGN PRESSURE RATING (+/-PSF)	IMPACT RATING
FIRST CHOICE 3600 CVR	40 7/8"	80	NONE
FIRST CHOICE 3600 CVR	40 7/8"	65	LARGE & SMALL MISSILE IMPACT
VON DUPRIN HH98/9947 CVR	40 5/8"	70	
FALCON HH1690 CVR	40 9/16"	50	
VON DUPRIN 98/9949 CV CABLE	40 5/8"		
JACKSON 2086 CVR	40 5/8"		
ADAMS G86 CVR	39 9/16"		
SARGENT AD/MD8400 CVR	40 9/16"		
SARGENT MD8600 CVR	40 9/16"		
CALIBRE 9100 CVR	40 9/16"		

ELEVATION C			
QUALIFIED LOCKING HARDWARE	BOTTOM OF DOOR TO LOCK CENTERLINE	DESIGN PRESSURE RATING (+/-PSF)	IMPACT RATING
FIRST CHOICE 3600 CVR WITH VON DUPRIN 111018-4954 REMOVABLE MULLION WITH MODIFIED VON DUPRIN REMOVABLE MULLION CLIPS AND ALUMINUM ANGLE CLIPS.	40 7/8"	100	LARGE & SMALL MISSILE IMPACT
ACTIVE: ADAMS-RITE 1853A (DEADLOCK 3-POINT WITH FLUSH BOLTS MS1850S 1-1/2 BACKSET, 4015 THRESHOLD BOLT AT BOTTOM OF PANEL, 4016 BOLT AT TOP OF PANEL) INACTIVE: 4085 HEADER BOLT ON TOP OF PANEL AND INTERNATIONAL F1203 MANUAL FLUSH BOLT ON BOTTOM OF PANEL	35 1/2"		

**OTHER APPROVED HARDWARE FOR ELEV. A, B, AND C:**

- MORTISED HD HAGER BUTT HINGE BB-1199 (PART #P1558) WITH TWO BUTT HINGE REINF. (PART #P2092) PER HINGE:  
3'X7' NOM. MAX. PANEL: THREE HINGES PER PANEL AT 6" MAX. FROM BOTTOM OF DOOR AND 36 1/2" O.C. THEREAFTER.  
4'X8' NOM. MAX. PANEL: FOUR HINGES PER PANEL AT 5 1/2" MAX. FROM BOTTOM OF DOOR AND 28" O.C. THEREAFTER.
- ROCKWOOD BF156 / SP47 PUSH-PULL HANDLES
- INTERNATIONAL SERIES 300 CONCEALED CLOSER
- MAX. DP 50 PSF: RIXON OFFSET PIVOT HINGES 180/147/M19L, FOUR HINGES PER PANEL AT TOP AND BOTTOM OF PANEL AND TWO EQUALLY SPACED BETWEEN, WITH TOP PIVOT AND INTERMEDIATE PIVOT REINFORCEMENTS
- MAX. DP 50 PSF: CONTINUOUS HINGE SELECT SL11HD
- MAX. DP 70 PSF: CONTINUOUS HINGE HAGER-ROTON 780 OR PEMKO KCFM-95HD1

**OTHER APPROVED HARDWARE OPTIONS FOR ELEV. C ONLY:**

- ROCKWOOD BF156/157 / SP47 OR BF15747 PUSH-PULL HANDLES
- DORMA 8616 SURFACE MOUNT CLOSER

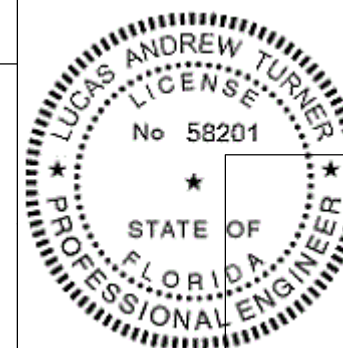

10/13/2017  
LUCAS A. TURNER, P.E.  
FL PE # 58201  
TURNER ENGINEERING & CONSULTING, INC.  
(COA # 29779)  
1239 JABARA AVE.  
NORTH PORT, FL 34288  
PH. 941-380-1574

TUBELITE  
FORCEFRONT  
HURRICANE SERIES  
MONUMENTAL DOORS - DRY SET  
IN CURTAINWALL FRAME

3065 WALKER RIDGE DRIVE N.W.  
WALKER, MICHIGAN 49544  
PH: 606.866.2227  
FX: 616.801.0008  
WEB SITE: WWW.TUBEITEINC.COM

**TUBELITE**  
DEPENDABLE  
LEADERS IN ECO-EFFICIENT STOREFRONT,  
CURTAINWALL AND ENTRANCE SYSTEMS

REVISION HISTORY:	
REV	DESCRIPTION
O	ORIGINAL RELEASE
A	ADDED CVR OPTION
B	REVISED FOR 2014 FBC
C	REVISED FOR 2017 FBC

DATE:	08.29.11
DRAWING NUMBER:	FPA-MON-HVHZ
DRAWN:	LT
FINAL REVIEW:	SW
SCALE:	N.T.S.
REVISION:	C
SHEET NAME:	
ELEVATIONS B AND C, HRDWARE NOTES	
SHEET:	2 OF 7

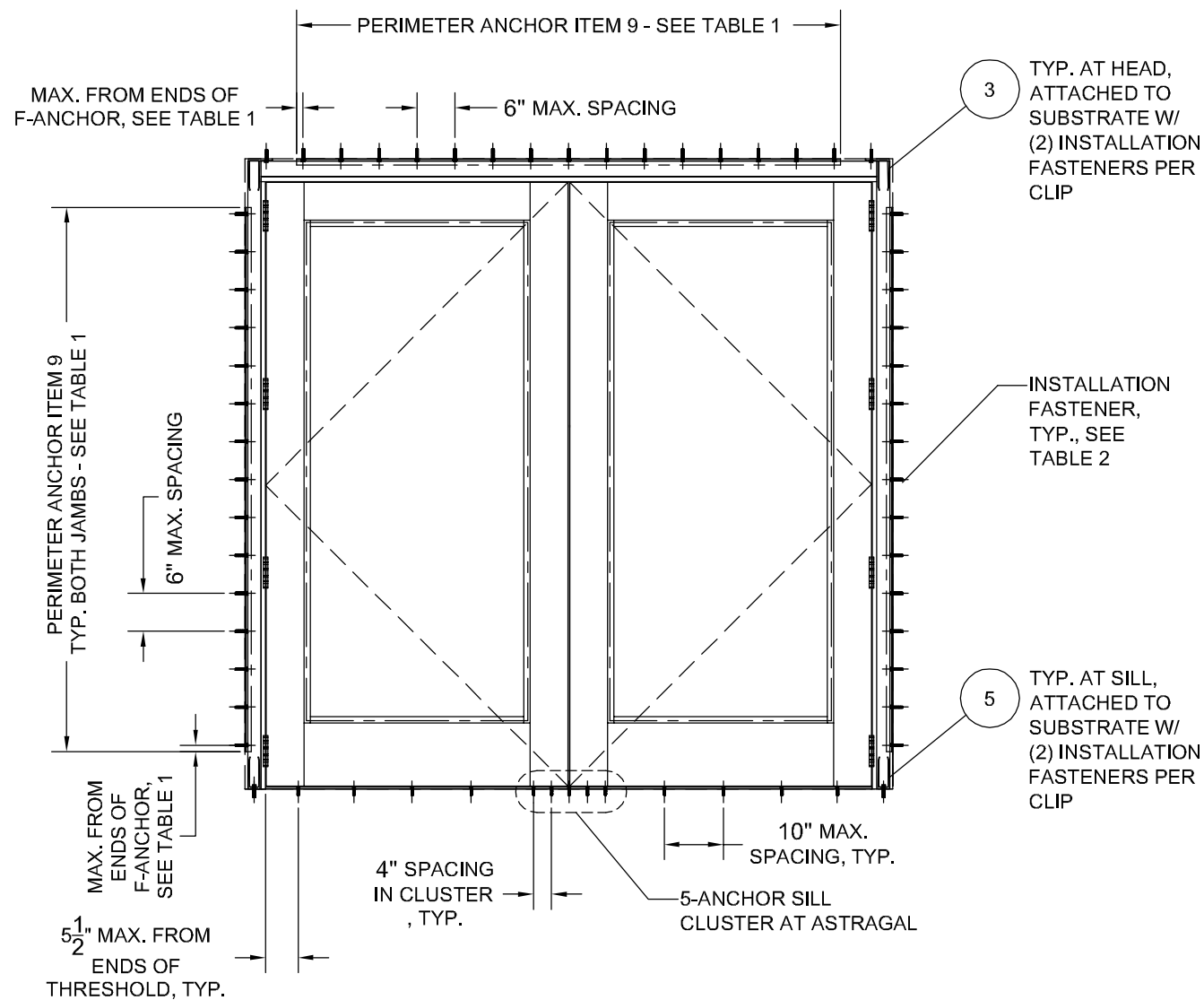

**ANCHORAGE ELEVATION**

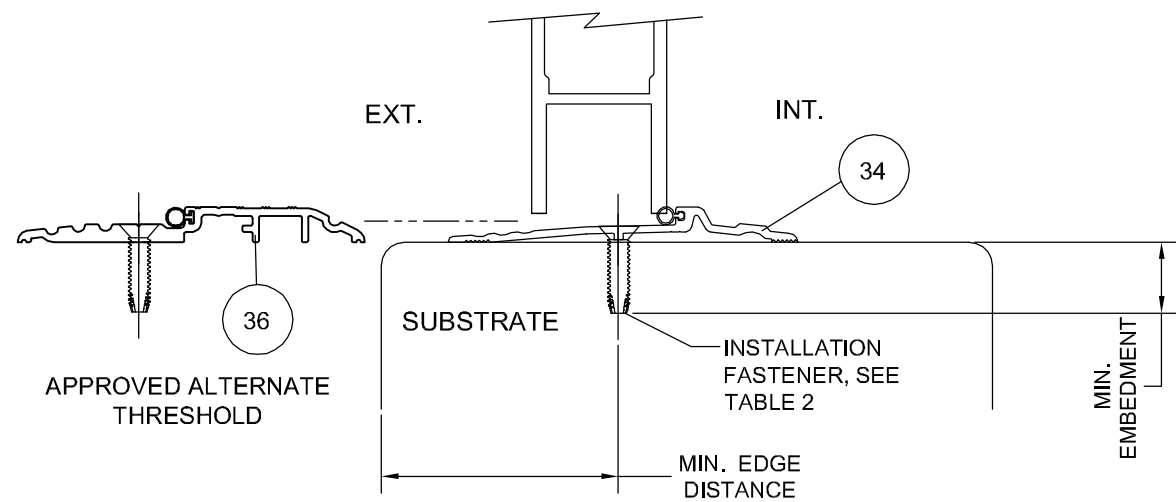

**TYP. SILL ANCHORAGE**

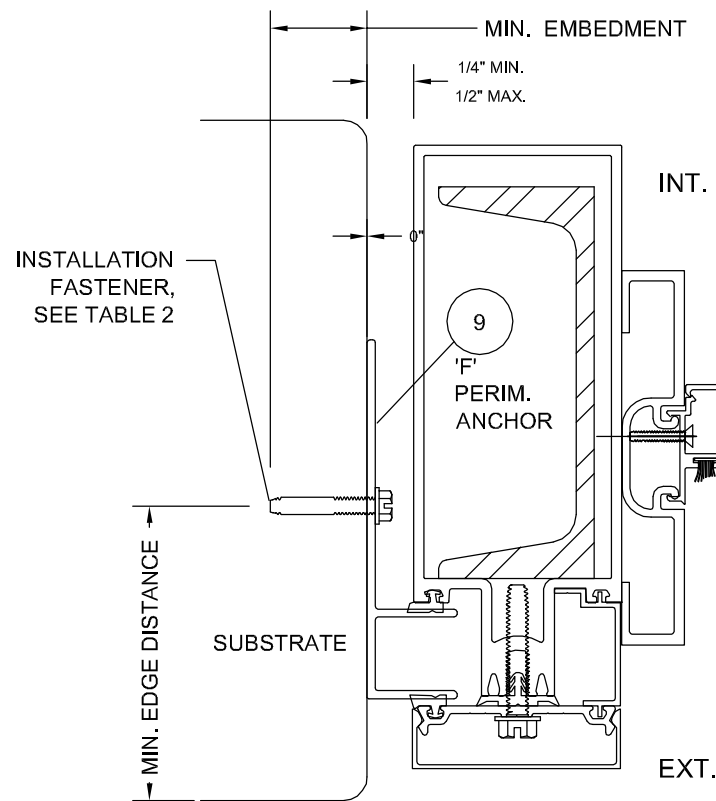

**TYP. HEAD/JAMB ANCHORAGE**

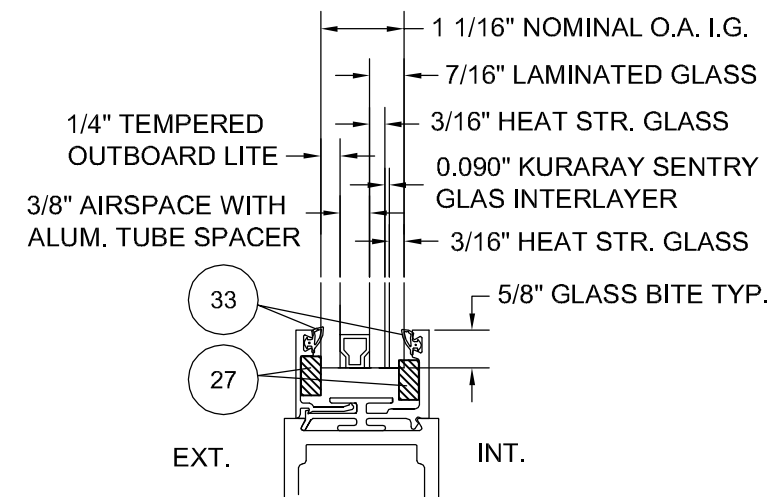

**GLAZING DETAIL**

**TABLE 1. F PERIMETER ANCHOR DETAILS**

DOOR SIZE	F PERIM. ANCHOR CUT LENGTH AT HEAD	MIN. ANCHOR DIST FROM ENDS OF 'F' AT HEAD	F PERIM. ANCHOR CUT LENGTH AT JAMBS	MIN. ANCHOR DIST FROM ENDS OF 'F' AT JAMBS
6' X 7'	5'-8"	4 1/2"	6'-0"	2 1/2"
8' X 8'	7'-2"	1"	7'-2"	1"

**TABLE 2. QUALIFIED ANCHOR INFORMATION**

ANCHOR	SUBSTRATE	MIN. EMBED.	MIN. EDGE DIST.
<b>HEAD, JAMB, AND SILL QUALIFIED ANCHORS - MASONRY OR METAL SUBSTRATE</b>			
3/8" REDHEAD DYNABOLT SLEEVE	CONCRETE (3.2 KSI MIN)	1 1/2"	4"
3/8" REDHEAD DYNABOLT SLEEVE	GROUT FILLED CMU	1 1/2"	4"
3/8" HILTI HLC SLEEVE	CONCRETE (3.2 KSI MIN)	1 1/2"	4"
3/8" HILTI HLC SLEEVE	GROUT FILLED CMU	1 1/2"	4"
3/8" HILTI KWIK BOLT III	CONCRETE (3.2 KSI MIN)	3"	4"
1/4" ITW TAPCON	CONCRETE (3.2 KSI MIN)	1 1/2"	3"
1/4" ITW TAPCON	GROUT FILLED CMU	1 1/4"	2 1/2"
1/4-20 F-TYPE GRADE 5	1/8" ALUM. 6063-T5 MIN.	SEE NOTE	1/2"
1/4-20 F-TYPE GRADE 5	1/8" STEEL 36 KSI MIN.	SEE NOTE	1/2"
<b>SILL QUALIFIED ANCHORS - WOOD SUBSTRATE</b>			
#14 WOOD SCREW GRADE 5	WOOD (G=0.42 MIN)	1 3/8"	1"
1/4" ITW TAPCON	WOOD (G=0.42 MIN)	1 3/8"	1"
<b>HEAD AND JAMB QUALIFIED ANCHORS - WOOD SUBSTRATE</b>			
3/8" LAG SCREW GRADE 5	WOOD (G=0.42 MIN)	4"	1 1/2"

NOTE: ANCHORS THROUGH METAL SHALL BE OF SUFFICIENT LENGTH TO PROVIDE THREAD ENGAGEMENT THROUGH THE FULL METAL THICKNESS



27  
 10/13/2017  
 LUCAS A. TURNER, P.E.  
 FL PE # 58201  
 TURNER ENGINEERING & CONSULTING, INC.  
 (COA # 29779)  
 1239 JABARA AVE.  
 NORTH PORT, FL 34288  
 PH. 941-380-1574

TUBELITE  
 FORCEFRONT  
 HURRICANE SERIES  
 MONUMENTAL DOORS - DRY SET  
 IN CURTAINWALL FRAME

3065 WALKER RIDGE DRIVE N.W.  
 PALM BEACH, MICHIGAN 49844  
 PH: 800.866.2227  
 FX: 616.901.0008  
 WEB SITE: WWW.TUBEITENING.COM

**TUBELITE**  
 DEPENDABLE  
 LEADERS IN ECO-EFFICIENT STOREFRONT,  
 CURTAINWALL AND ENTRANCE SYSTEMS

REVISION HISTORY:

REV	DATE	DESCRIPTION
O	3.29.11	ORIGINAL RELEASE
A	8.29.11	NO CHANGE THIS SHIT
B	4.29.15	REVISED FOR 2014 FBC
C	10.12.17	REVISED FOR 2017 FBC

DATE: 08.29.11  
 DRAWING NUMBER: FPA-MON-HVHZ  
 DRAWN: LT  
 FINAL REVIEW: SW  
 SCALE: N.T.S.  
 REVISION: C  
 SHEET NAME: ANCHORAGE INFORMATION, GLAZING DET.  
 SHEET: 3 OF 7

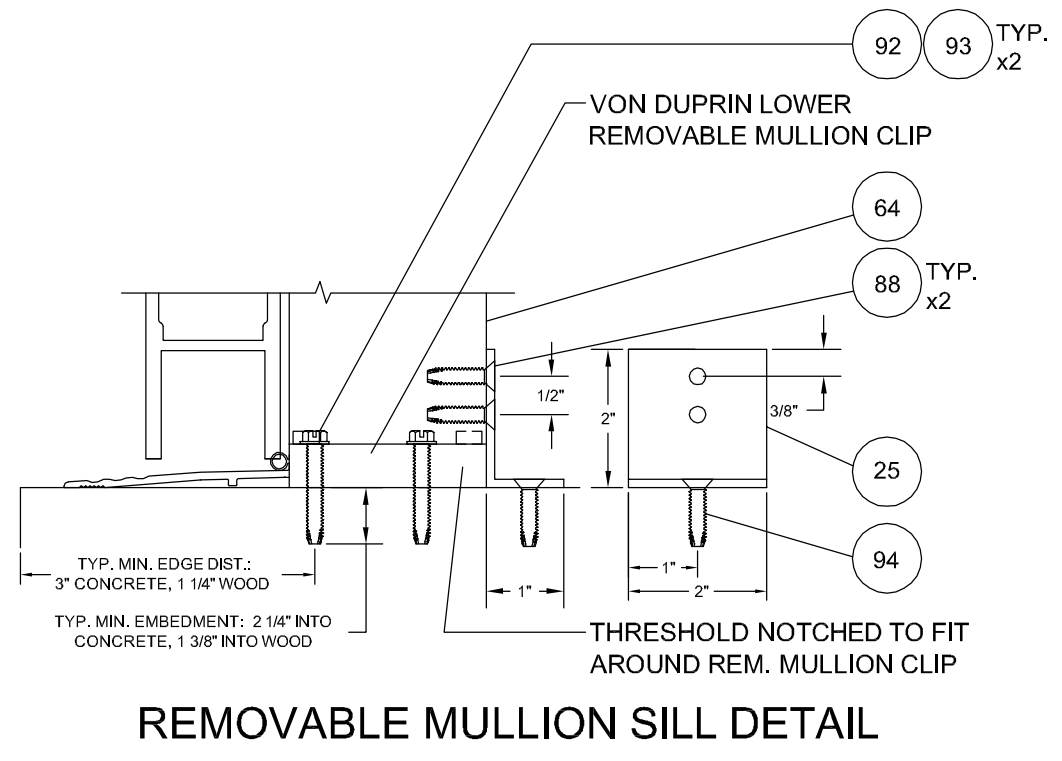
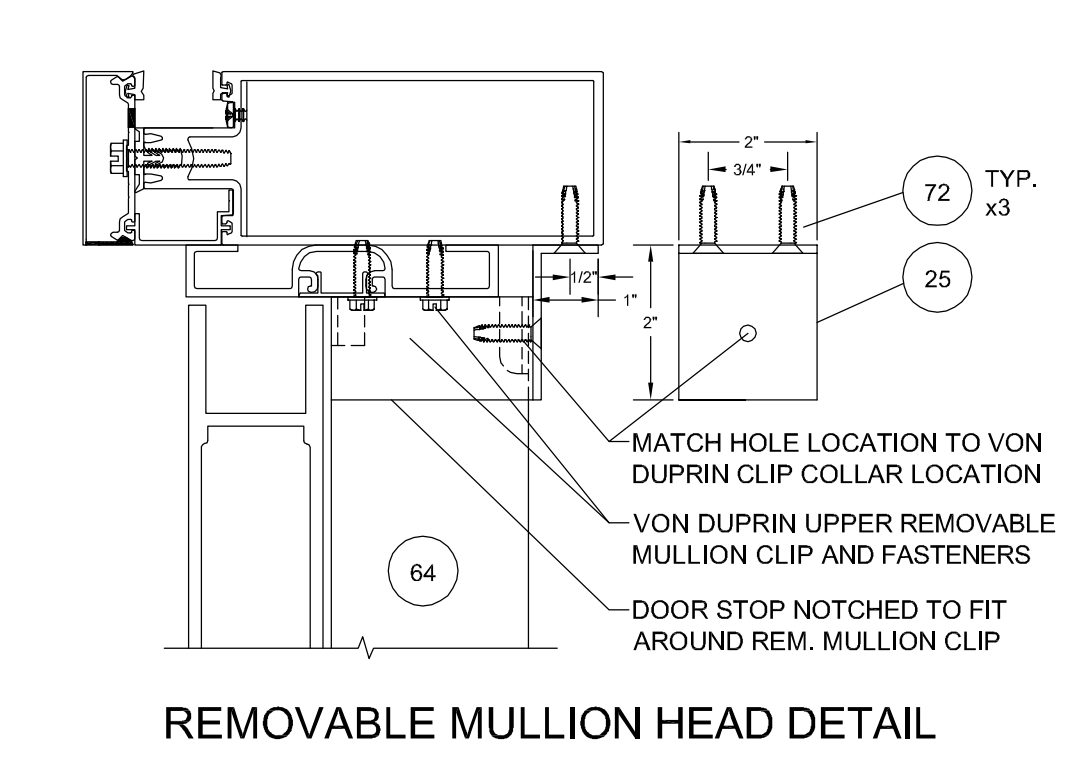
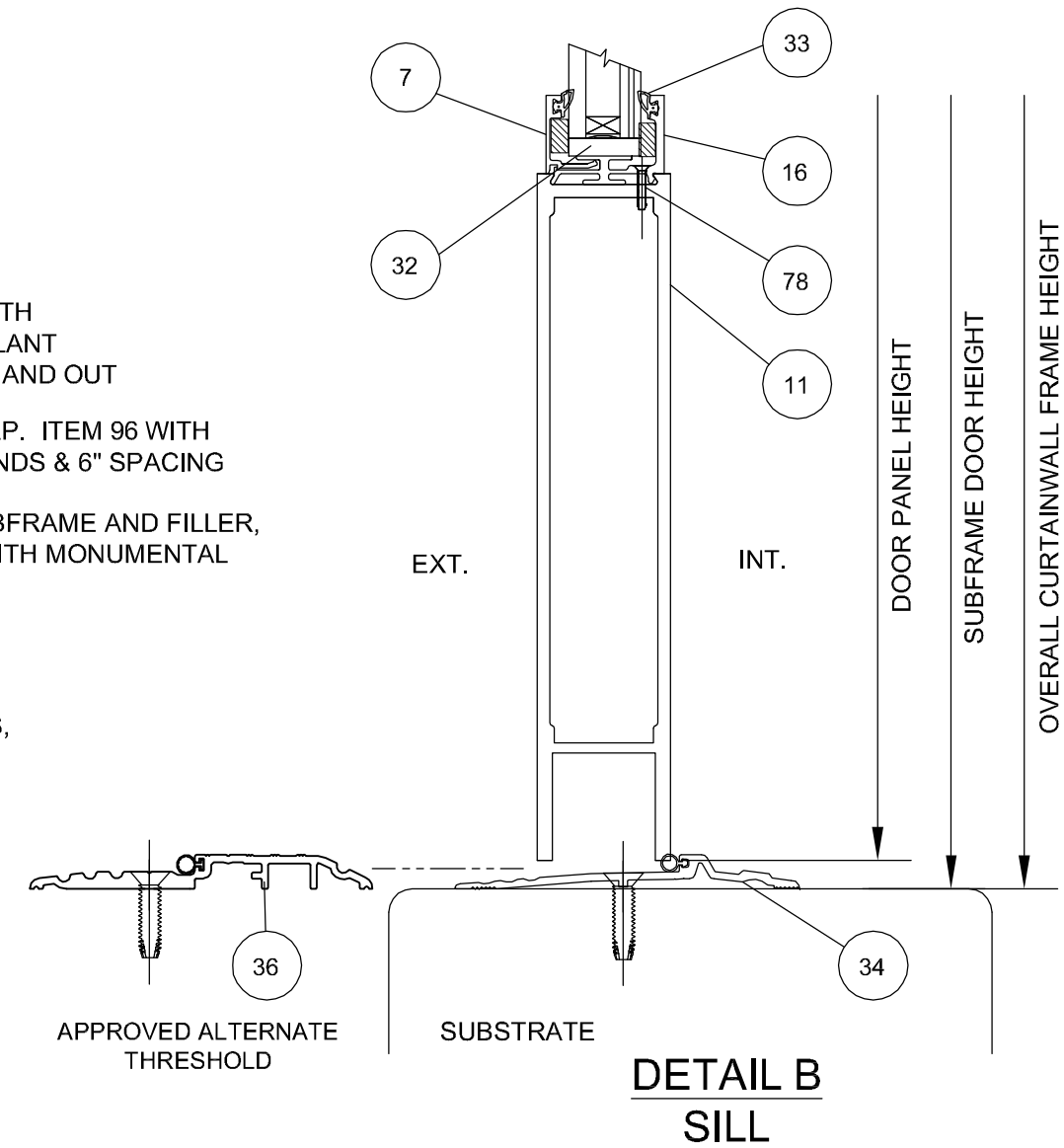
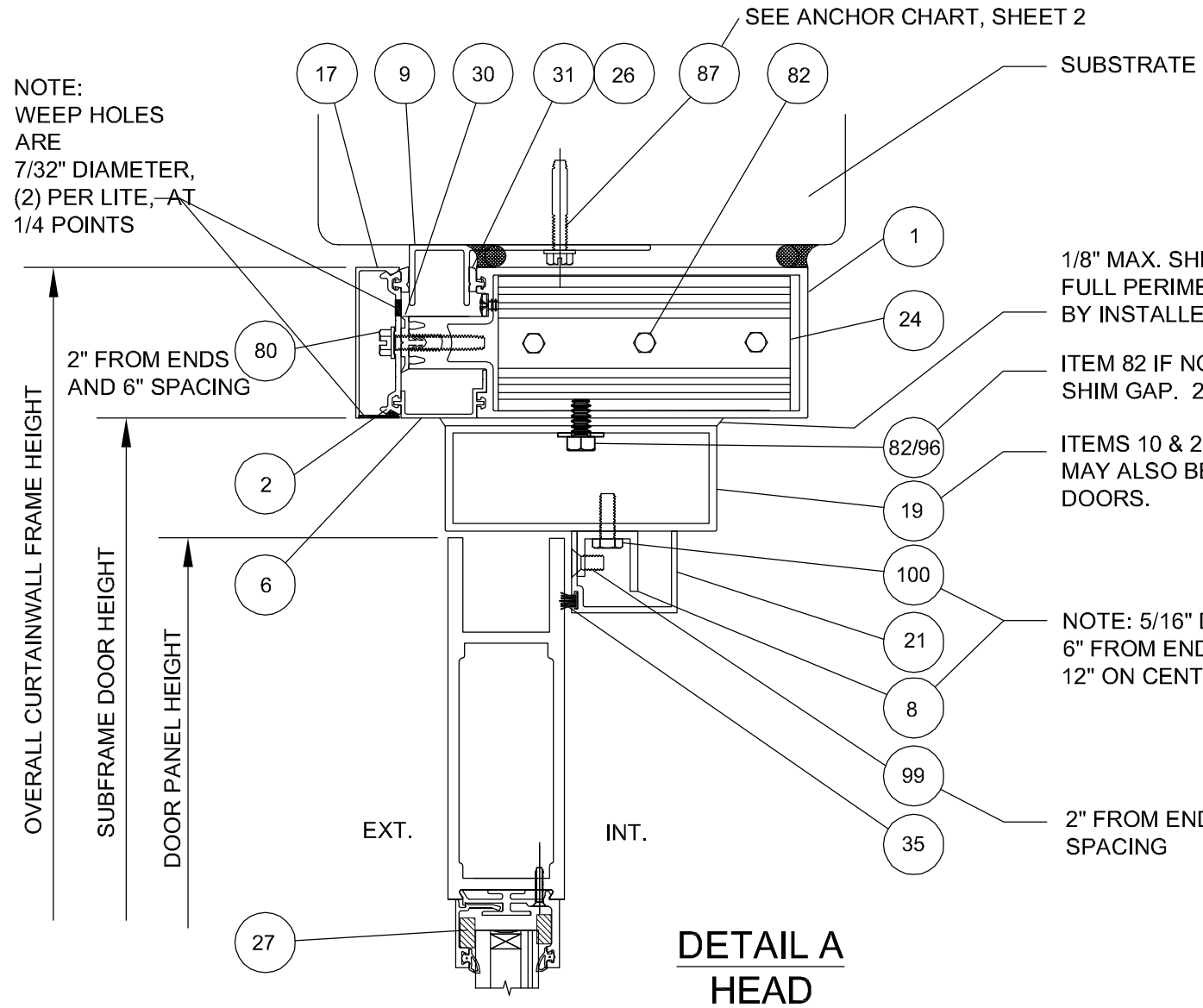

10/13/2017  
 LUCAS A. TURNER, P.E.  
 FL PE # 58201  
 TURNER ENGINEERING  
 & CONSULTING, INC.  
 (COA # 29779)  
 1239 JABARA AVE.  
 NORTH PORT, FL 34288  
 PH. 941-380-1574

**TUBELITE®**  
 FORCEFRONT  
 HURRICANE SERIES  
 MONUMENTAL DOORS - DRY SET  
 IN CURTAINWALL FRAME

3065 WALKER RIDGE DRIVE N.W.  
 PALM BEACH, MICHIGAN 49544  
 PH: 800.866.2227  
 FX: 616.501.0006  
 WEB SITE: WWW.TUBELITEINC.COM

**DEPENDABLE**  
 LEADERS IN ECO-EFFICIENT STOREFRONT  
 CURTAINWALL AND ENTRANCE SYSTEMS

REV	DATE	DESCRIPTION
O	3.29.11	ORIGINAL RELEASE
A	8.29.11	ADDED REM MULL
B	4.29.15	REVISED FOR 2014 FBC
C	10.12.17	REVISED FOR 2017 FBC

REVISION HISTORY:

DATE: 08.29.11  
 DRAWING NUMBER: FPA-MON-HVHZ  
 DRAWN: LT  
 FINAL REVIEW: SW  
 SCALE: N.T.S.  
 REVISION: C

SHEET NAME: SECTION VIEWS  
 SHEET: 4 OF 7

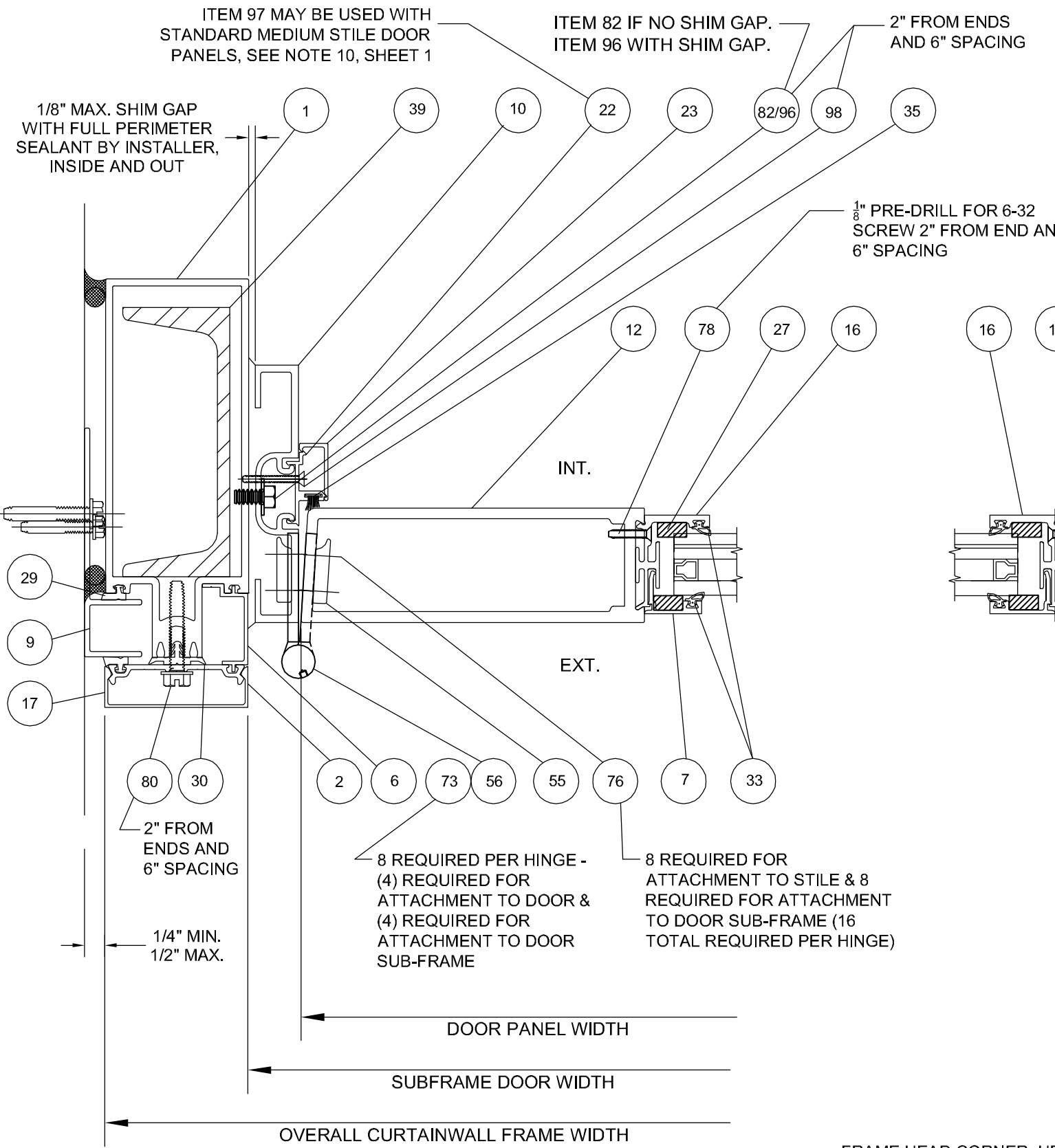

**DETAIL C  
JAMB**

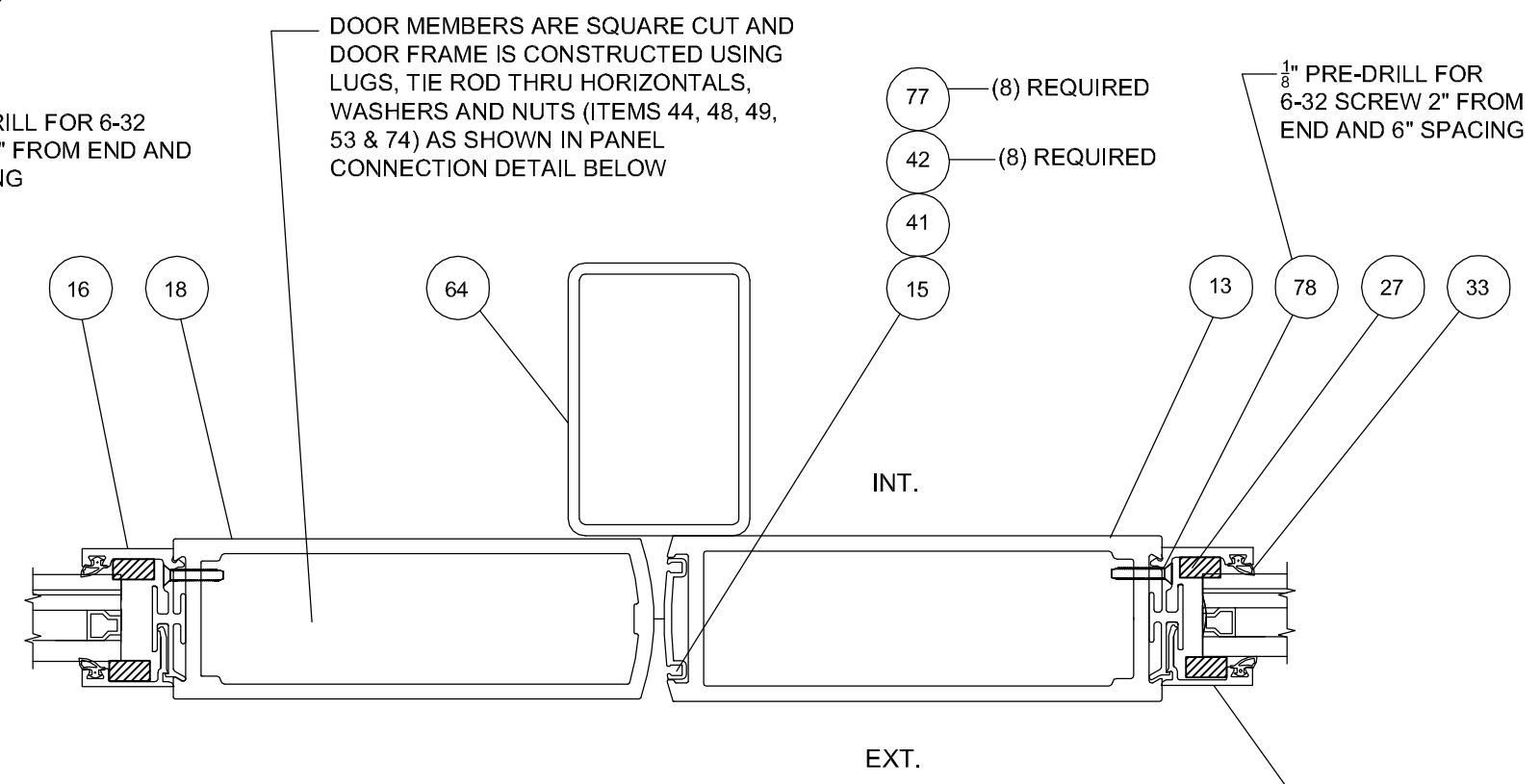

**DETAIL D  
ASTRAGAL STILES**

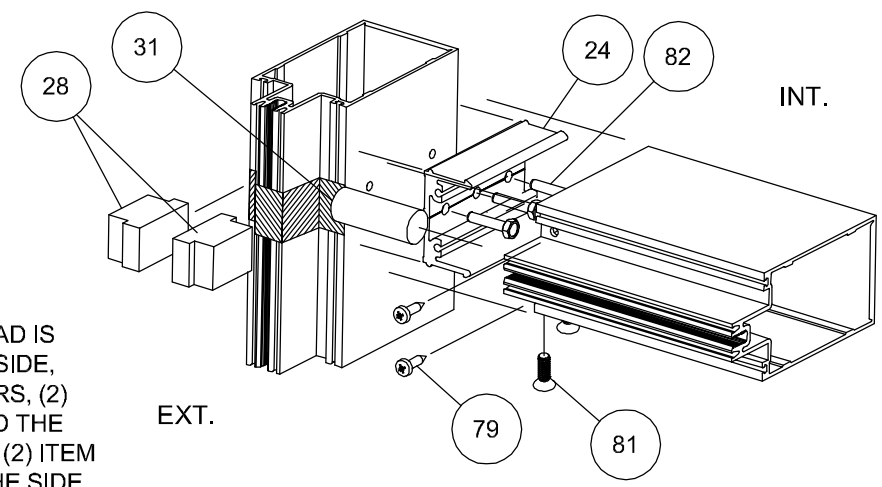

**CORNER ASSEMBLY DETAIL**

FRAME HEAD CORNER: HEAD IS SQUARE CUT, BUTTED TO SIDE, FASTENED WITH FASTENERS, (2) ITEM #81 & (3) ITEM #82 AND THE SCREW SPLINE FASTENER (2) ITEM #79 FASTENS THROUGH THE SIDE MEMBER INTO HEAD MEMBER AND SEALED WITH TREMCO DYMONIC FC SEALANT.



10/13/2017  
 LUCAS A. TURNER, P.E.  
 FL PE # 58201  
 TURNER ENGINEERING  
 & CONSULTING, INC.  
 (COA # 29779)  
 1239 JABARA AVE.  
 NORTH PORT, FL 34288  
 PH. 941-380-1574

**TUBELITE**  
**FORCEFRONT**  
**HURRICANE SERIES**  
 MONUMENTAL DOORS - DRY SET  
 IN CURTAINWALL FRAME

3065 WALKER RIDGE DRIVE N.W.  
 PALM BEACH, MICHIGAN 49844  
 PH: 800.866.2227  
 FX: 616.501.0008  
 WEB SITE: WWW.TUBELITEINC.COM

**TUBELITE**  
**DEPENDABLE**  
 LEADERS IN ECO-EFFICIENT STOREFRONT  
 CURTAINWALL AND ENTRANCE SYSTEMS

REV	DATE	DESCRIPTION
O	3.29.11	ORIGINAL RELEASE
A	8.29.11	MOVED CORN ASSY
B	4.29.15	REVISED FOR 2014 FBC
C	10.12.17	REVISED FOR 2017 FBC

DATE: 08.29.11  
 DRAWING NUMBER:  
**FPA-MON-HVHZ**  
 DRAWN: LT  
 FINAL REVIEW: SW  
 SCALE: N.T.S.  
 REVISION: C

SHEET NAME:  
**SECTION VIEWS**  
 SHEET: 5 OF 7

BILL OF MATERIALS			
ITEM	PART NUMBER	DESCRIPTION	MATERIAL
1	E55TB02	EXTRUSION, TUBE, NON-THERMAL	ALUMINUM - 6063-T5
2	E4TB63	EXTRUSION, PRESSURE PLATE, 2-1/2 HEAVY	ALUMINUM - 6063-T5
3	PTB20AB	ANCHOR, 'F' CUT & PRE-DRILLED. LG P/N A=4.761", B=5.053"	ALUMINUM - 6063-T6
4	PTB21AB	ANCHOR, 'T' CUT & PRE-DRILLED. LG P/N A=4.761", B=5.053"	ALUMINUM - 6063-T6
5	PTB22	ANCHOR, 'U' CUT & PRE-DRILLED	ALUMINUM - 6063-T6
6	E3192	EXTRUSION, FILLER, GLASS POCKET	ALUMINUM - 6063-T5
7	E6503	EXTRUSION, GLAZING STOP (MACH. & INSTALLED)	ALUMINUM - 6063-T5
8	E6504	STOP, INNER 1" X 1" DOOR STOP PRE-DRILLED	ALUMINUM - 6063-T5
9	E3162	EXTRUSION, 'F' PERIMETER ANCHOR	ALUMINUM - 6063-T5
10	E4TB11	EXTRUSION, SUB-FRAME, DOOR, 3/4 X 4-1/2 (MACHINED)	ALUMINUM - 6063-T5
11	E2954	EXTRUSION, RAIL, BOTTOM, OR TOP, 10" (DOOR)	ALUMINUM - 6063-T5
12	E2937	EXTRUSION, STILE, WIDE - HINGE LEFT (DOOR)	ALUMINUM - 6063-T5
13	E1155	EXTRUSION, STILE, WIDE - LOCK LEFT (DOOR)	ALUMINUM - 6063-T5
14	E1051	EXTRUSION, RAIL, BOTTOM OR TOP, 6" (DOOR)	ALUMINUM - 6063-T5
15	E1152	EXTRUSION, ASTRAGAL (DOOR)	ALUMINUM - 6063-T5
16	E6502	EXTRUSION, VERT & HORIZ GLASS STOP (DOOR)	ALUMINUM - 6063-T5
17	E4TB64	EXTRUSION, COVER, FACE, 2-1/2 X 3/4 (DOOR)	ALUMINUM - 6063-T5
18	E2938	EXTRUSION, DOOR STILE (DOOR)	ALUMINUM - 6063-T5
19	E0041	EXTRUSION, SUBFRAME HEAD (DOOR)	ALUMINUM - 6063-T5
20	E4011	EXTRUSION, POCKET FILLER (DOOR FRAME)	ALUMINUM - 6063-T5
21	E2298	EXTRUSION, HORIZONTAL DOOR STOP (DOOR)	ALUMINUM - 6063-T5
22	E6500	BASE, STOP, VERT DOOR PRE-DRILLED 102" (FRAME)	ALUMINUM - 6063-T5
23	E6501	COVER, STOP, VERTICAL DOOR 102" (FRAME)	ALUMINUM - 6063-T5
24	PTB60	CLIP, FRAME, SHEAR BLOCK (3 HOLES) (CW)	ALUMINUM - 6063-T5
25	E3826	CLIP, TOP & BOTTOM, REMOVABLE MULLION	-
26	-	TREMCO DYMONIC FC POLYURETHANE HYBRID SEALANT	-
27	-	TREMCO SGT-900 SERIES STRUCTURAL GLAZING TAPE 1/4" X 1/2"	-
28	PTB93	DAM, WATER, SINGLE POCKET	P-PART - FOAM
29	PTB28	GLAZING, FIXED, 3/8 THICK (400CW)	P-PART - RUBBER
30	PTB94	GASKET, THERMAL BARRIER, EPG (PRESSURE PLATE)	P-PART - RUBBER
31	P1094	ROD, ETHAFOAM 3/4" DIA X 2" LONG	P-PART - FOAM
32	P1912	BLOCK, SETTING, 1/4 X 1/2 X 4" LONG	P-PART - RUBBER
33	P0017	GASKET, GLASS, EPG (MONUMENTAL DOOR)	P-PART - RUBBER
34	P6525-0R	THRESHOLD XB896N-0R W/GASKET - NAT'L GUARD PRODUCTS	P-PART - ALUMINUM
35	P1098A	PILE, DOOR STOP, AMESBURY GROUP	P-PART - PLASTIC/FABRIC
36	E3550	EXTRUSION ~ THRESHOLD	ALUMINUM - 6063-T6
37	P6505	STEEL, BAR STOCK 1 X 4-1/2 X 135"	P-PART - STEEL
38	P6504	STEEL, BAR STOCK 1-1/4 X 4-1/2 X 135"	P-PART - STEEL
39	P6507	STEEL, CHANNEL C4 - 1.58 X 4 X 135"	P-PART - STEEL
40	P6506	STEEL, TUBE, 1-1/2 X 3 X 1/8 WALL	P-PART - STEEL
41	P1539	SPRING, STEEL, ASTRAGAL, ADJUSTABLE, (DOOR)	P-PART - HARDWARE
42	P1553	WASHER, SCREW & SHOULDER SCREW (DOOR)	P-PART - FASTENER
43	P518	LABEL, DOOR, GREEN BRUSHED SILVER (DOOR)	P-PART - LABEL
44	P1648	LUG FOR TUBE E2954/E2669/DOOR RAIL E1051	P-PART - HARDWARE
45	S908	SCREW, 10-24 X 1/2 FH MACH PHIL (DOOR)	P-PART - FASTENER
46	-	-	-
47	P6533	MS 1881 ADAMS-RITE TWO POINT FLUSH BOLT	P-PART - HARDWARE
48	P020B	ROD, THREADED TIE, 3/8" (DOOR)	P-PART - HARDWARE
49	P908	LUG, DOOR, FOR RAIL E1051 (DOOR)	P-PART - HARDWARE
50	P676	TAB - FOR MORTISED LOCKS (DOOR)	P-PART - HARDWARE
51	P1010	ADAMS RITE 4015 BOLT & BOLT GUIDE, THRESHOLD (DOOR)	P-PART - HARDWARE
52	P6509	ADAMS-RITE 4016-10 HEADER BOLT/GUIDE (DOOR)	P-PART - HARDWARE
53	P853	WASHER, DOOR ROD (DOOR)	P-PART - HARDWARE
54	-	-	-
55	P2092	HINGE, BUTT, REINFORCEMENT (P092) (DOOR)	P-PART - HARDWARE
56	P1558	HINGE, BUTT, MORTISED HD (DOOR)	P-PART - HARDWARE
57	P572	CYLINDER PARTS, P572-C2 (DOOR)	P-PART - HARDWARE
58	P1825	M-SR-SR28 COLLAR, SPLIT RING CYL RYADON (DOOR)	P-PART - HARDWARE
59	P6508	ADAMS-RITE MS1853S-410-000 ADAMS-RITE (DOOR)	P-PART - HARDWARE
60	P059	STANDARD FLUSH BOLT INTERNATIONAL F1203 (DOOR)	P-PART - HARDWARE

ITEM	PART NUMBER	DESCRIPTION	MATERIAL
61	P849	STANDARD FLUSH BOLT GUIDE (DOOR)	P-PART - HARDWARE
62	P1750	HEADER BOLT, ADAM-RITE 4085 (DOOR)	P-PART - HARDWARE
63	P571	CYLINDER, LOCK (DOOR)	P-PART - HARDWARE
64	P6511	REMOVABLE MULLION, VON DUPRIN 111018-4954	-
65	P6510	BF15747 PUSH/PULL BAR SET, 33" ROCKWOOD (DOOR)	P-PART - HARDWARE
66	P2201	CLOSER, DORMA, 8616, SURFACE MOUNT	P-PART - HARDWARE
67	SF7284	ASSEMBLY, FRAME, DOOR, MONUMENTAL	DOOR FRAME ASSEMBLY
68	MW7284L	ASSEMBLY, STILE, WIDE, PAIR LEFT, MONUMENTAL	DOOR ASSEMBLY LEFT
69	MW7284R	ASSEMBLY, STILE, WIDE, PAIR RIGHT, MONUMENTAL	DOOR ASSEMBLY RIGHT
70	P1564	BF156 PULL BAR, ROCKWOOD (DOOR)	P-PART - HARDWARE
71	-	-	-
72	S092	SCREW, 1/4-20 X 1-1/2 FLAT HEAD PHIL	P-PART - FASTENER
73	S070	SCREW, FLAT HEAD, 12-24 X 1/2" (HINGE SCREW)	P-PART - FASTENER
74	S071	NUT, STUD, 3/8-16 X 3/8 (DOOR TIE ROD)	P-PART - FASTENER
75	S186	WASHER, 1/2 OD X 1/4 ID X .062 ALUMINUM (DOOR)	P-PART - FASTENER
76	S161	SCREW, 10-24 X 1/2 FLAT HEAD PHIL (DOOR HINGE)	P-PART - FASTENER
77	S341	SCREW, PHIL HEAD, 10-24 X 3/4 (ASTRAGAL)	P-PART - FASTENER
78	S6504	SCREW, 6-32 X 1 FT HD PHIL, TYPE F (glass stop/dr stop)	P-PART - FASTENER
79	S270	SCREW, 10-24 X 3/4 PAN HEAD PHIL, SS (shear block)	P-PART - FASTENER
80	S359	SCREW, 1/4-20 1-1/2 HEX HD TYPE F (pres plate)	P-PART - FASTENER
81	S191	SCREW, 10-24 X 1/2 TRUSS HEAD PHIL (horiz mull & dr stop)	P-PART - FASTENER
82	S139	SCREW, 1/4-20 X 1/2 HEX HEAD TYPE B (shear blk)	P-PART - FASTENER
83	S6505	SCREW, 1/4-20 X 3/4 HHCS TYPE F THREAD CUTTING (SUB-FR & H STOP)	P-PART - FASTENER
84	S6506	SCREW, 1/4-20 X 1-1/2 FLAT HEAD PHIL (sill-steel/v stop/h stop)	P-PART - FASTENER
85	S155	SCREW, 1/4-20 X 3" FLAT HEAD PHIL (reinforcing steel)	P-PART - FASTENER
86	S055	SCREW, #12 X 3" FLAT HEAD PHIL (threshold into wood)	P-PART - FASTENER
87	S6501	SCREW, 3/8-16 X 2 HEX HD (T, F, U & PERMETER)	P-PART - FASTENER
88	S0002	SCREW, 3/8 X 2-1/2" LAG GALVINIZED (FOR WOOD SUBSTRATE)	P-PART - FASTENER
89	-	8616 SURFACE MOUNT CLOSER, DORMA	P-PART - HARDWARE
90	P6531	SERIES 300 CONCEALED CLOSER, INTERNATIONAL DOOR CLOSERS, INC.	P-PART - HARDWARE
91	P1077	3020-VO-AL CONCEALED CLOSER ARM, INTERNATIONAL	P-PART - HARDWARE
92	-	SCREW, 5/16 ITW TAPCON (Removable Mull Installation)	P-PART - FASTENER
93	-	SCREW, 5/16 WOOD LAG SCREW GRADE 5 (Removable Mull Installation)	P-PART - FASTENER
94	-	SCREW, 1/4 ITW TAPCON (Removable Mull Installation)	P-PART - FASTENER
96	S369	SCREW, 1/4-20 3/4 HEX HD TYPE CA (SUBFRAME W/ SHIM)	P-PART - FASTENER
97	E6511	EXTRUSION, POCKET FILLER (STANDARD DOOR FRAME)	ALUMINUM - 6063-T6
98	S6509	SCREW, 6-32 X 1-1/4 FLAT HEAD CLASS 2A (GLASS STOP/DOOR STOP)	P-PART - FASTENER
99	S131	SCREW, 8-32 5/16 FLAT HEAD PHIL (DOOR STOP)	P-PART - FASTENER
100	S403	SCREW, 1/4-20 X 1" HWH TYPE 23 SELF-TAPPING (DOOR STOP)	P-PART - FASTENER

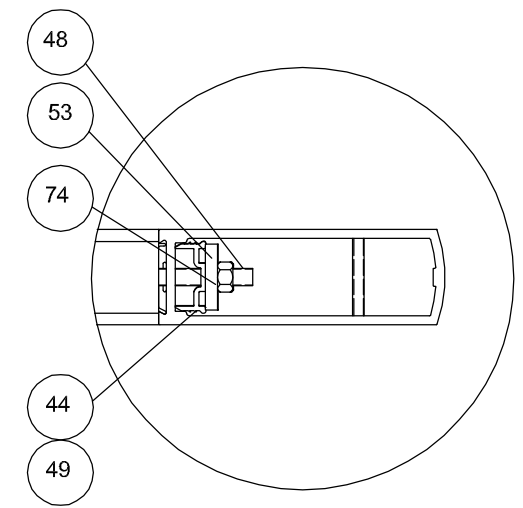

**PANEL CONNECTION DETAIL**

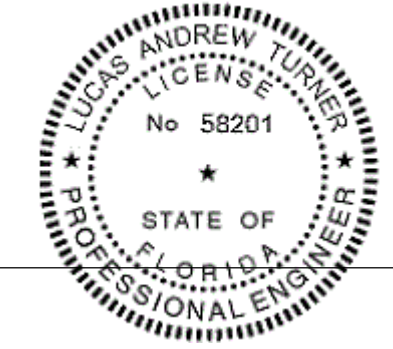

10/13/2017  
 LUCAS A. TURNER, P.E.  
 FL PE # 58201  
 TURNER ENGINEERING & CONSULTING, INC.  
 (COA # 29779)  
 1239 JABARA AVE.  
 NORTH PORT, FL 34288  
 PH. 941-380-1574

**TUBELITE**  
**FORCERONT**  
**HURRICANE SERIES**  
**MONUMENTAL DOORS - DRY SET**  
**IN CURTAINWALL FRAME**

3065 WALKER RIDGE DRIVE N.W.  
 WALKER, MICHIGAN 49544  
 PH: 606.866.2227  
 FX: 616.501.0006  
 WEB SITE: WWW.TUBELITEINC.COM

**TUBELITE**  
**DEPENDABLE**  
**LEADERS IN ECO-EFFICIENT STOREFRONT**  
**CURTAINWALL AND ENTRANCE SYSTEMS**

REV	DATE	DRAWN	DESCRIPTION
0	3.29.11	KAR/HLT	ORIGINAL RELEASE
A	8.29.11	LT	CHANGED PART #S
B	4.29.15	LT	REVISED FOR 2014 FBC
C	10.12.17	LT	REVISED FOR 2017 FBC

REVISION HISTORY:  
 DATE: 08.29.11  
 DRAWING NUMBER: FPA-MON-HVHZ  
 DRAWN: LT  
 FINAL REVIEW: SW  
 SCALE: N.T.S.  
 REVISION: C  
 SHEET NAME: BILL OF MATERIALS  
 SHEET: 6 OF 7

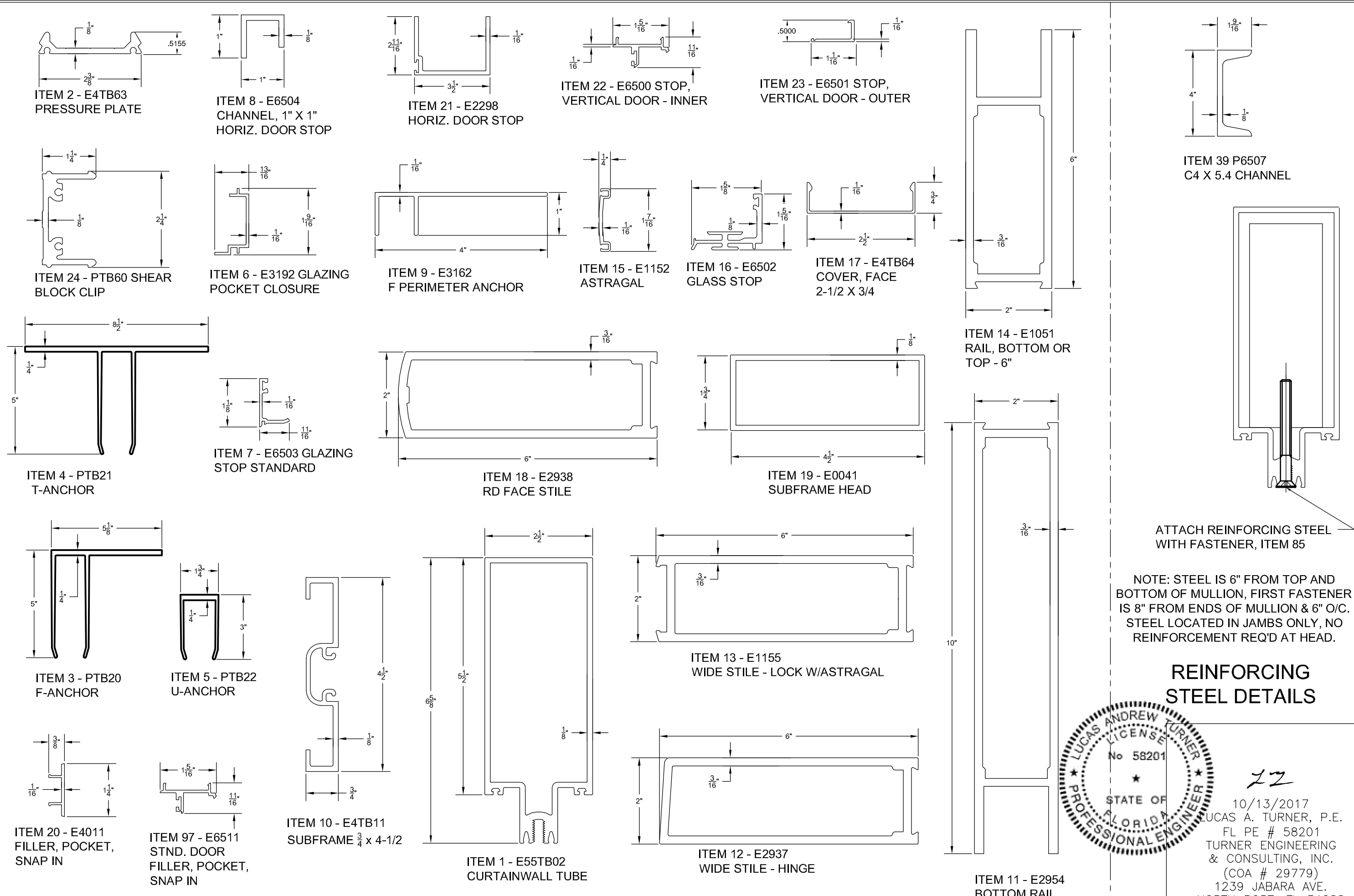

**EXTRUSION PROFILES: MONUMENTAL DOOR IN CURTAINWALL FRAME**

ATTACH REINFORCING STEEL WITH FASTENER, ITEM 85

NOTE: STEEL IS 6" FROM TOP AND BOTTOM OF MULLION, FIRST FASTENER IS 8" FROM ENDS OF MULLION & 6" O/C. STEEL LOCATED IN JAMBS ONLY, NO REINFORCEMENT REQ'D AT HEAD.

**REINFORCING STEEL DETAILS**

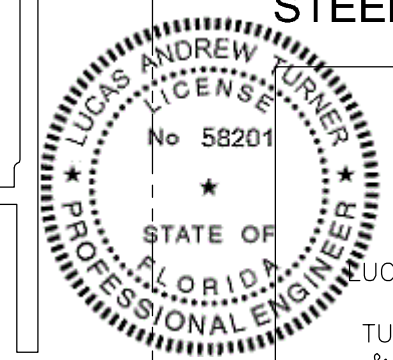

22  
 10/13/2017  
 LUCAS A. TURNER, P.E.  
 FL PE # 58201  
 TURNER ENGINEERING & CONSULTING, INC.  
 (COA # 29779)  
 1239 JABARA AVE.  
 NORTH PORT, FL 34288  
 PH. 941-380-1574

TUBELITE  
 FORCEFRONT  
 HURRICANE SERIES  
 MONUMENTAL DOORS - DRY SET  
 IN CURTAINWALL FRAME

3065 WALKER RIDGE DRIVE N.W.  
 PALM BEACH, MICHIGAN 49844  
 PH: 800.866.2227  
 FX: 616.501.0008  
 WEB SITE: WWW.TUBELITEINC.COM

**TUBELITE**  
 DEPENDABLE  
 LEADERS IN ECO-EFFICIENT STOREFRONT,  
 CURTAINWALL AND ENTRANCE SYSTEMS

REVISION HISTORY:	
REV	DESCRIPTION
O	ORIGINAL RELEASE
A	ADDED ITEM 19
B	REVISED FOR 2014 FBC
C	REVISED FOR 2017 FBC

DATE: 08.29.11

DRAWING NUMBER: FPA-MON-HVHZ

DRAWN: LT

FINAL REVIEW: SW

SCALE: N.T.S.

REVISION: C

SHEET NAME: EXTRUSION PROFILES AND REINF. DETAILS

SHEET: 7 OF 7