

Evaluation Report "Cee-Lock Panel" With Continuous Cee-Rib Clip Metal Roof Assembly

Manufacturer:
Berridge Manufacturing Company

**1720 Maury Road
Houston, TX 77026
(800) 231-8127**

for

Florida Product Approval

FL 14210.2 R5

Florida Building Code 7th Edition (2020)

Method: 1 - D

Category: Structural Components

Sub - Category: Roof Deck

Product: "Cee-Lock" Roof Panel

Material: Steel

Panel Thickness: 22 gauge

Panel Width: 16.5"

Support: Steel Purlins

Prepared by:

James L. Buckner, P.E., S.E.C.B.
Florida Professional Engineer # 31242
Florida Evaluation ANE ID: 1916
Project Manager: Diana Galloway
Report No. 20-227-CL-S2P-ER
(Revises Report No. 17-128-CL-S2P-ER, FL14210.2 R4)
Date: 09 / 17 / 20

This item has been electronically signed and sealed by James L. Buckner, P.E., on this date using a Digital Signature. Printed copies of this document are not considered signed and sealed, and the signature must be verified on any electronic copies.

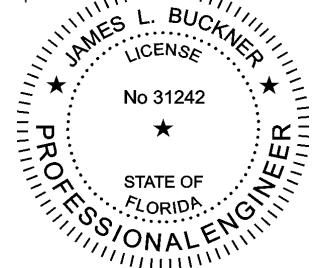

A handwritten signature in blue ink that reads "James L. Buckner".

2020.10.15 19:45:20 -04'00'

Contents:

Evaluation Report Pages 1 – 8

CBUCK, Inc. dba CBUCK Engineering

Phone: (561) 491-9927 · Email: cbuck@cbuckinc.net · Website: www.cbuckinc.net

Business: 1374 Community Dr., Jupiter, FL 33458 · Corp/Mailing: 2637 E. Atlantic Blvd, #34069, Pompano Beach, FL 33062

Manufacturer:	Berridge Manufacturing Company 1720 Maury Road Houston, TX 77026 (800) 231-8127 www.berridge.com
Product Name:	"Cee-Lock"
Product Category:	Structural Components
Product Sub-Category	Roof Deck
Compliance Method:	State Product Approval Rule 61G20-3.005 (1) (d)
Product/System Description:	"Cee-Lock" Snap-Lock Roof Panel 1-1/2" Rib Height, 16.5" wide, 22 gauge Steel roof panel restrained by Continuous Cee-Rib panel clips fastened into Steel Purlins.
Product Assembly as Evaluated:	Refer to Page 4 of this report for product assembly components/materials & standards: <ol style="list-style-type: none">1. Roof Panel2. Panel Clip3. Fasteners4. Insulation (Optional)
Support:	Type: Steel Purlins (Design of steel support and its attachment to support framing is outside the scope of this evaluation.) Description: <ul style="list-style-type: none">• 16 Gauge minimum• Yield Strength: 50 ksi minimum
Slope:	Minimum slope shall be in compliance with FBC Chapter 15 based on the type of roof covering, applicable code sections and in accordance with manufacturer's recommendations.
Performance:	Wind Uplift Resistance: <ul style="list-style-type: none">• Design Uplift Pressure: (Refer to "Table A" attachment details herein) METHOD 1: - 85 PSF METHOD 2: - 150 PSF

- Performance Standards:** The product described herein has demonstrated compliance with:
- ASTM E 1592-05 – *Test Method for Structural Performance of Sheet Metal Roof and Siding Systems By Uniform Static Air Pressure Difference*
 - TAS 125-03 – *Standard Requirements for Metal Roofing Systems*
- Standards Equivalency:** The ASTM E 1592-01 standard version used to test the product meets the prescribed standards in ASTM E 1592-05 standard version adopted by the Florida Building Code 7th Edition (2020) for use as evaluated in this report.
- Code Compliance:** The product described herein has demonstrated compliance with Florida Building Code 7th Edition (2020), Section 1504.3.2.
- Evaluation Report Scope:** This product evaluation is limited to compliance with the structural requirements of the Florida Building Code, as related to the scope section to Florida Product Approval Rule 61G20-3.001.
- Limitations and Conditions of Use:**
- Diaphragm and axial load capacity is outside the scope of this evaluation.
 - Scope of “Limitations and Conditions of Use” for this evaluation:
This evaluation report for “Optional Statewide Approval” contains technical documentation, specifications and installation method(s) which include “Limitations and Conditions of Use” throughout the report in accordance with Rule 61G20-3.005. Per Rule 61G20-3.004, the Florida Building Commission is the authority to approve products under “Optional Statewide Approval”.
 - Option for application outside “Limitations and Conditions of Use”
Rule 61G20-3.005(1)(e) allows engineering analysis for “project specific approval by the local authorities having jurisdiction in accordance with the alternate methods and materials authorized in the Code”. Any modification of the product as evaluated in this report and approved by the Florida Building Commission is outside the scope of this evaluation and will be the responsibility of others.
 - This report is a building code product evaluation per FLPE rule (FAC) 61G15-36 to comply with Florida product approval rule (FAC) 61G20-3. This evaluation report is part of the Florida Building Commission approval for the listed code related criteria. This report by James Buckner, P.E. and CBUGK Engineering is not a design certification of code compliance construction submittal documentation, per FBC section 107, for any individual structure, site specific or permit design.
 - All metal components and fasteners shall be corrosion resistant in accordance with applicable sections of FBC.
 - Design of support system is outside the scope of this report. Support shall be designed by others and shall comply with the FBC Chapters 22 for steel and Chapter 16 for structural loading.
 - Fire Classification is outside the scope of Rule 61G20-3, and is therefore not included in this evaluation.
- Quality Assurance:** The manufacturer has demonstrated compliance of roof panel products in accordance with the Florida Building Code and Rule 61G20-3.0005 (3) for manufacturing under a quality assurance program audited by an approved quality assurance entity through **UL, LLC (FBC Organization #: QUA 9625)**.

**Components/Materials
(by Manufacturer):**

Roof Panel:
Material: Berridge "Cee-Lock"
Steel
Thickness: 22 gauge (min.)
Panel Width: 16.5" (max.) Coverage
Rib Height: 1-1/2"
Yield Strength: 40 ksi min.
Steel Grade: 40
Corrosion Resistance: In compliance with FBC Section 1507.4.3:

- ASTM A792 coated, or
- ASTM A653 G90 galvanized steel

Roof Panel Clips:
Type: Berridge "Cee-Rib" Clip
One-Piece, fixed continuous clip
Material: Steel
Thickness: 24 Gauge
Dimensions: 1-7/16" (tall) x 1-3/8" (wide) x continuous
(w/panel length)
Yield Strength: 40 ksi min.
Corrosion Resistance: Per FBC Section 1506.7

Fastener:
Type: Low Profile Self-Drilling, Self-Tapping Screws
Size: 1/4" -14 x 1"
Corrosion Resistance: Per FBC Section 1506.6 and 1507.4.4
Standard: Per FBC Section 1506.6

**Components& Materials: Insulation (Optional):
(by Others)**

Type 1:
Type: Rigid Insulation Board
Thickness: 3" (max.)
Properties:
Density: 20 psi min.
Or Compressive Strength: 2.25 pcf (lbs/ft³) min.

Type 2:
Type: Compressible Blanket Insulation
Thickness: 6" max. before compression

Insulation Notes:

- Rigid Insulation shall meet minimum density OR compressive strength.
- Insulation shall comply with FBC Section 1508. When insulation is incorporated, fastener length shall conform to penetrate thru bottom of support a minimum of 3/4".

Installation:

Installation Method:

(Refer to "TABLE A" below and drawings at the end of this report.)

- Purlin Spacing: **Refer to "TABLE A" Below**
- Two (2) fasteners (at each purlin intersection)
- Rib Interlock: Snap-Lock
(Panel ribs shall be fully engaged to form an integral snap-lock.)
- Minimum fastener penetration thru bottom of support, 3/4".
(through flange of steel purlins)

TABLE "A"		
ALLOWABLE LOADS		
	METHOD 1	METHOD 2
Design Pressure:	- 85 PSF	- 150 PSF
# of Fasteners per Purlin Intersection:	2	2
Max. Purlin Spacing:	48"	24"
Span Condition:	3 or more	3 or more
Notes: <ul style="list-style-type: none">• Allowable design pressure(s) for allowable stress design (ASD).• Fastener Attachment to Steel Supports May Be Designed By A Qualified Design Professional As Required By The Florida Building Code For Site Specific Projects.• Diaphragm and axial load capacity are not included in this evaluation.		

Install the "Cee-Lock" roof panel assembly in compliance with the installation method listed in this report and applicable code sections of FBC 7th Edition (2020). The installation method described herein is in accordance with the scope of this evaluation report. Refer to manufacturer's installation instructions as a supplemental guide for attachment.

Referenced Data:

1. TAS 125-03 (Per ASTM E 1592-01)
By Force Engineering & Testing Inc., Inc.
(FBC Organization #TST ID: 5328)
Report # 49-0354T-08G & H, Dated 1/14/09
2. Quality Assurance
UL, LLC (FBC Organization #: QUA 9625)
3. Equivalency of Test Standard Certification
By James L. Buckner, P.E. @ CBUG Engineering
(FBC Organization # ANE 1916)
4. Certification of Independence
By James L. Buckner, P.E. @ CBUG Engineering
(FBC Organization # ANE 1916)

**Installation Method
Berridge Manufacturing Company
"Cee-Lock" Steel Roof Panel attached to Steel Purlins**

Drawings

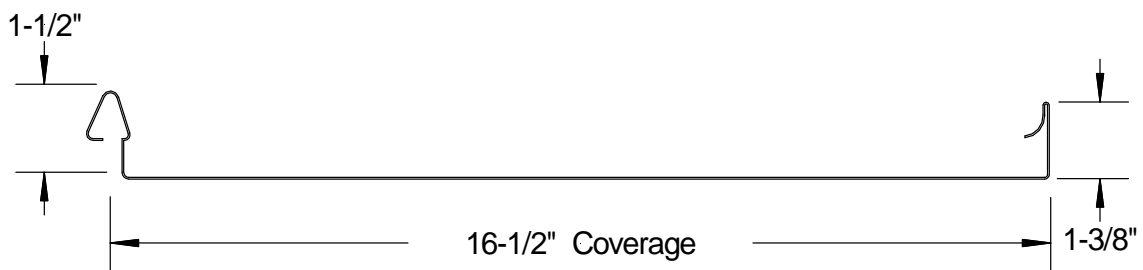

Typical Panel Profile

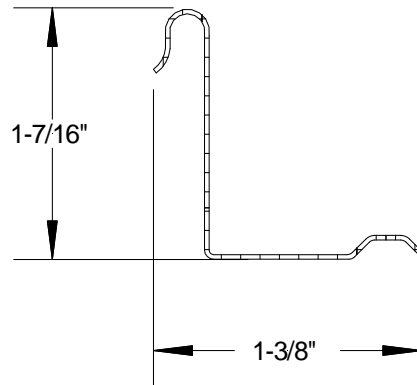

**Berridge Continuous "Cee-Rib"
Panel Clip Profile Side View**

Installation Method Berridge Manufacturing Company "Cee-Lock" Steel Roof Panel attached to Steel Purlins

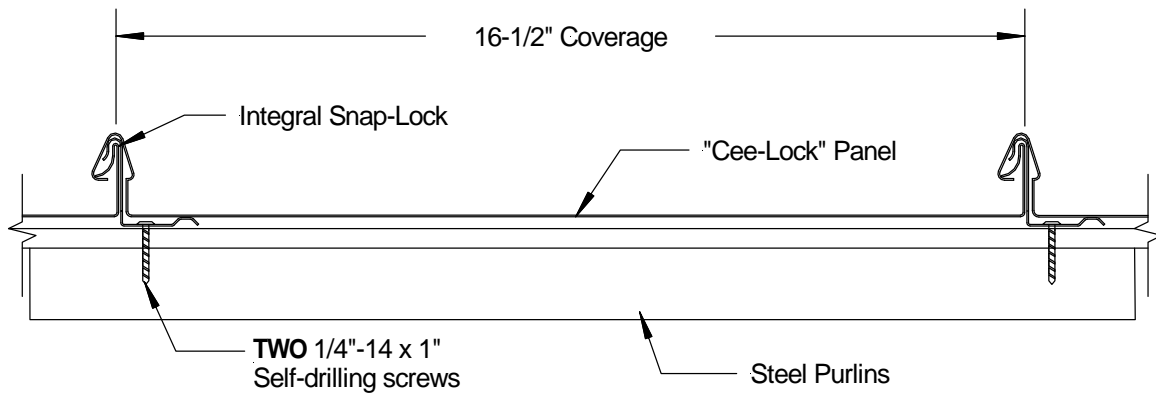

Typical Assembly Profile View (Typical Fastening Pattern Across Width)

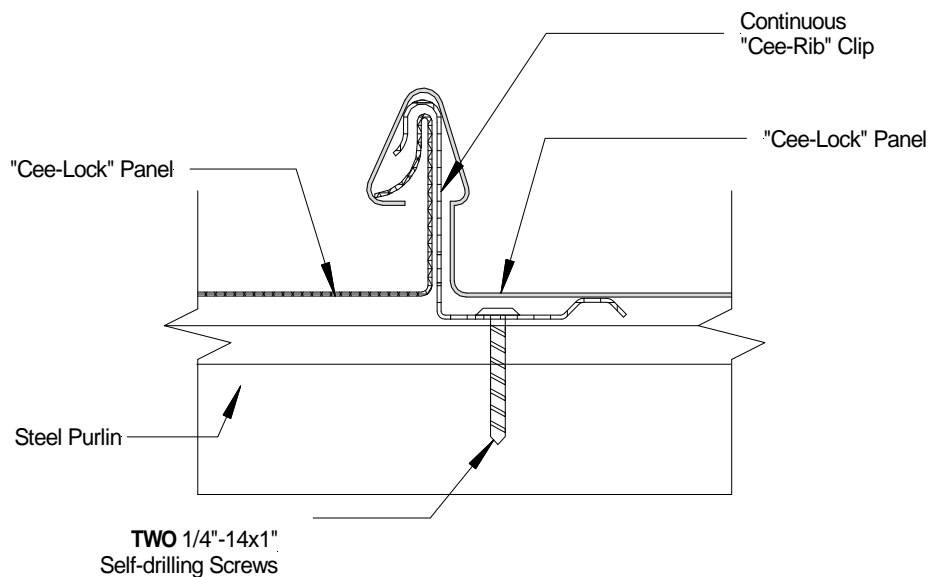

Typical Panel Clip Assembly Side Profile View

Installation Method Berridge Manufacturing Company "Cee-Lock" Steel Roof Panel attached to Steel Purlins

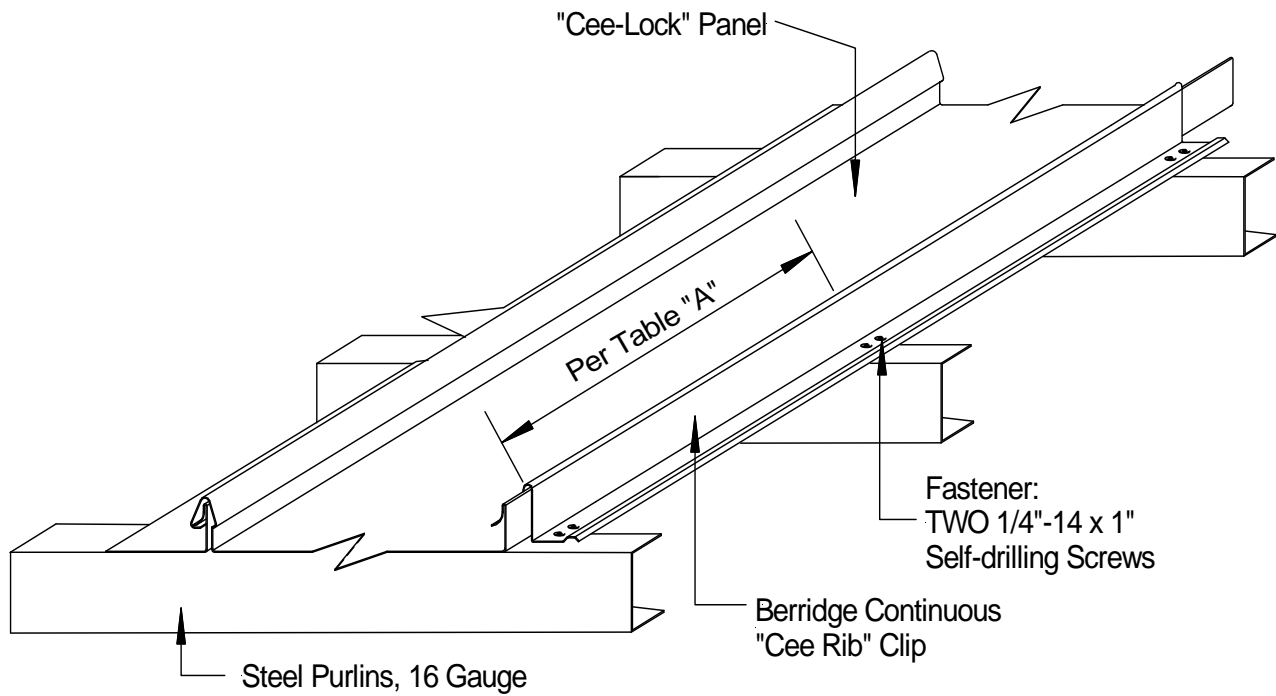

**Typical Roof Assembly
 Isometric View**

TABLE "A"		
	METHOD 1	METHOD 2
Design Pressure:	- 85 PSF	- 150 PSF
# of Fasteners per Purlin Intersection:	2	2
Max. Purlin Spacing:	48"	24"
Span Condition:	3 or more	3 or more