

CORNELL IRON WORKS, INC.

Operation & Maintenance Manual

Products: Rolling Doors

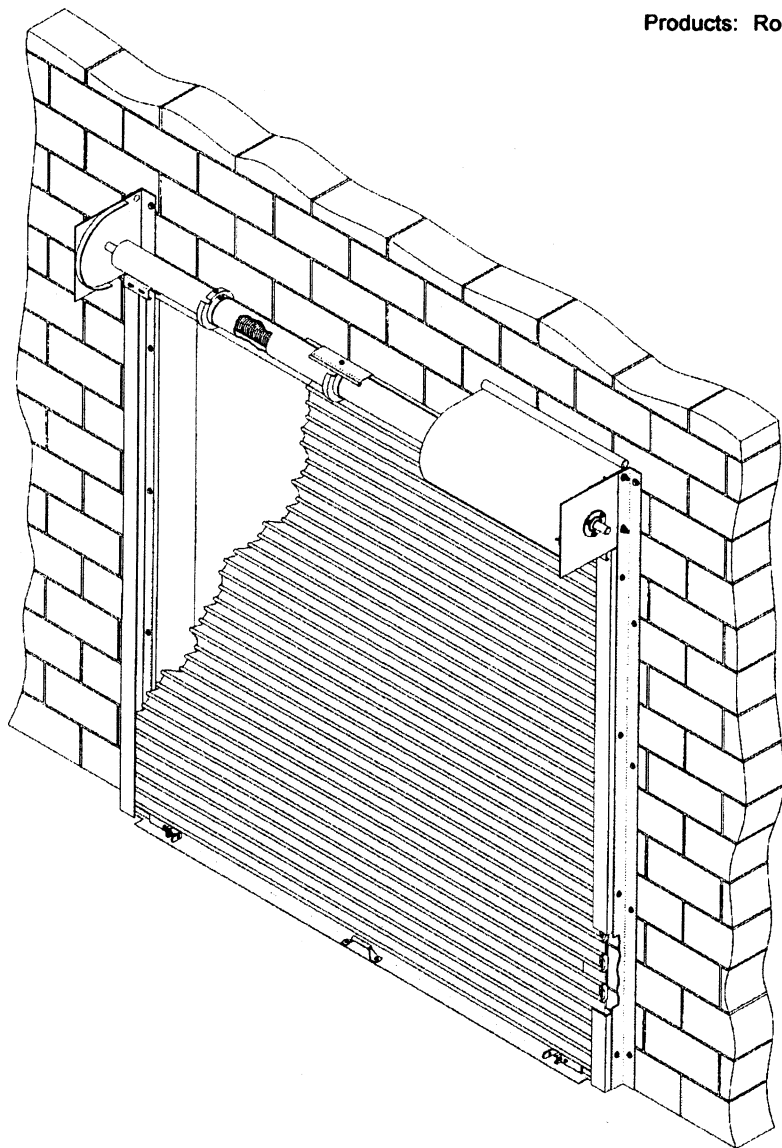

Rolling door specialists
CORNELL
IRON WORKS
New solutions
Since 1925

For more information...
Contact the Service Department
Please Call 800-233-8366
Or Fax 800-526-0841

Crestwood Industrial Park, Mountaintop, PA 18707



PARTS LIST - SERVICE DOORS

PUSH-UP, HAND CRANK, CHAIN OR
MOTOR OPERATED, FACE MOUNTED
LEFT HAND ADJUST SHOWN, FACING COIL SIDE

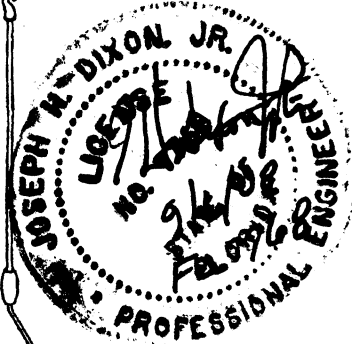
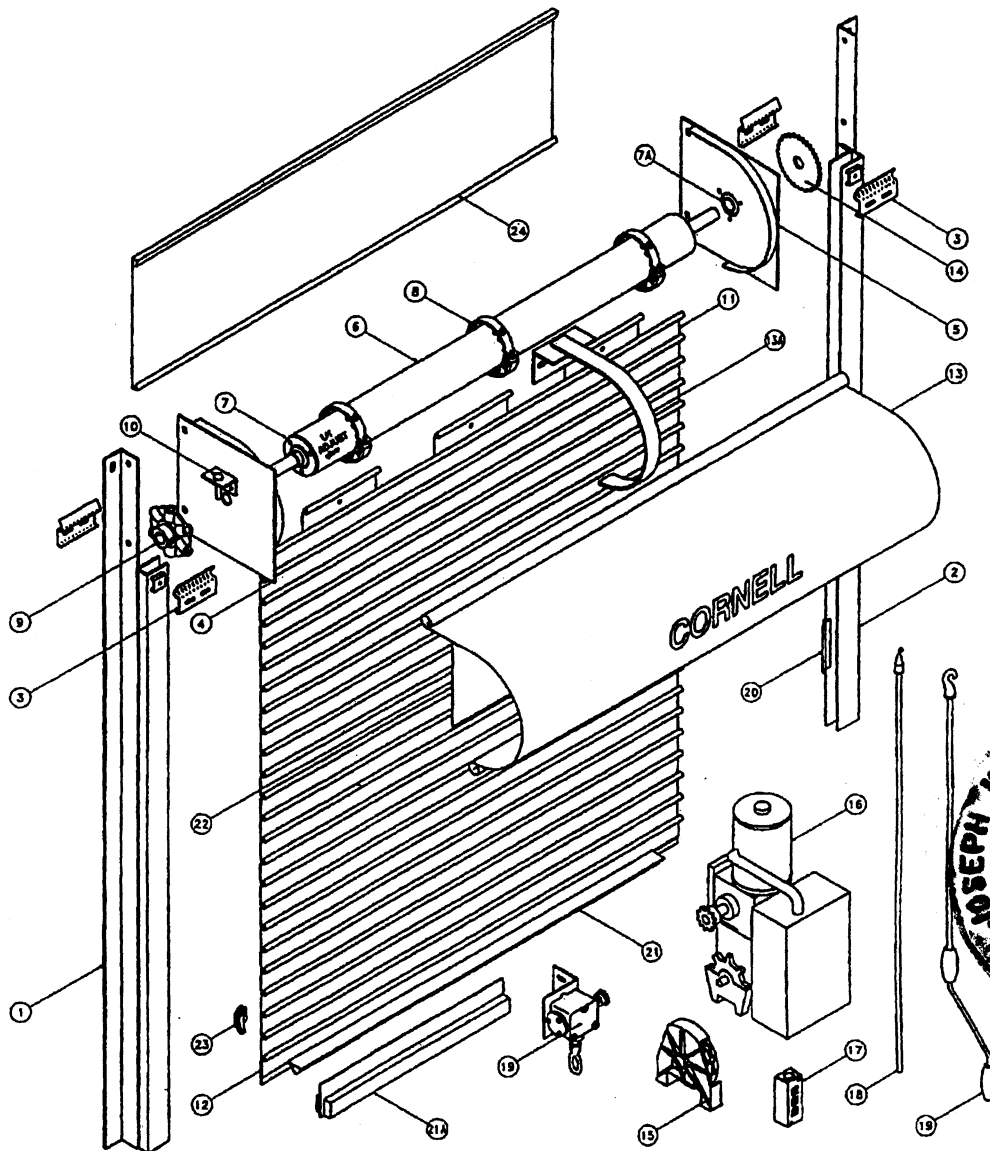

PRICES BASED ON STANDARD PRIMED GALVANIZED COMPONENTS. CONSULT FACTORY FOR OTHER FINISHES. PRICES MAY VARY ON DOORS LARGER THAN 24'-0" X 12'-0". CONSULT FACTORY FOR LARGER SIZES.

1	LEFT HAND GUIDE & WALL ANGLE	9	ADJUSTOR WHEEL	17	PUSH BUTTON STATION
2	RIGHT HAND GUIDE & WALL ANGLE	10	ADJUSTOR PIN	18	POLE & HOOK - PUSH-UP DOORS
3	COMBINATION BELLMOUTH & STOPPER	11	CURTAIN SLAT FASTENING SECTIONS	19	AWNING TYPE CRANK & OPERATOR
4	ADJUSTOR BRACKET	12	DOUBLE ANGLE BOTTOM BAR	20	GUIDE WEATHERING
5	OPERATOR BRACKET	13	SHEET METAL HOOD	21	ASTRAGAL (OPTIONAL)
6	BARREL (COUNTERBALANCE SHAFT)	13A	HOOD SUPPORT - WIDE DOORS	21A	SAFETY EDGE (OPTIONAL)
7	ROLLER BEARING - ADJUSTOR END	14	CHAIN SPROCKET	22	HOOD BAFFLE (OPTIONAL)
7A	ROLLER BEARING - OPERATOR END	15	CHAIN OPERATOR	23	ENDLOCK
8	RINGS	16	MOTOR OPERATOR	24	FASCIA (OPTIONAL)

ROLLING STEEL DOORS

INSTALLATION INSTRUCTIONS

(Push-up, Hand Crank, Chain or Motor Operated)

NOTE: Prior to installation read all instructions. Open all crates to insure that all parts supplied correspond to parts list for type door being installed.

- STEP 1** Check opening width and height dimensions for agreement with those shown on the shop drawing, they should correspond. With guides on floor, run 5/16" diameter self-tapping screws into bellmouth/stopper mounting pads at top of guide assembly (four places). This will aid in bellmouth/stopper installation later.
- STEP 2** Find best level working line such as the lintel. Check shop drawings for any set back of guides from face of opening then set in place the left hand guide (1) plumb. Set the right hand guide (2) equidistance top and bottom and level with left hand guide as shown on plan of shop drawing. Mark off holes, using the upper section of the slot hole (this will allow for any leveling adjustment if required). Center punch marks and drill and tap if fastening to steel or drill for expansion shields when mounting to masonry.
- STEP 3** Locate a good hoisting point above the center of the opening and set in place a chain block (if no other hoisting equipment is available). On larger doors it is advisable to use two chain blocks.
- STEP 4** Place the spring counterbalance pipe shaft (6) at the base of the guides. Check the markings on the shaft. The adjusting end will always be marked L.H., or R.H. Adjust. Left and right hand is always relative to the side of the opening on which you are installing the door. Place shaft according to these marks.
- STEP 5** Hoist shaft 2 or 3 feet from floor and install rings (8) (if required). Pipe shaft will have holes drilled and tapped for ring studs or direct curtain attachment. 4" and 6" pipes will use either rings or direct curtain attachment. Larger diameter pipes will use direct curtain attachment only. For ring installation (take note of the direction of coil to insure installing the ring in the proper direction.) Next place the adjustor bracket (4) on the adjustor end of the shaft. This bracket is recognizable by a section of angle bolted above the center of the bracket. The adjustor pin (10) is packaged with the hardware. Install the adjusting wheel (9) on the inner shaft with roll pin at this time.

NOTE: On smaller between jams push-up doors the adjustor bracket will have a lug with a hole. The shaft will have a "inside" adjusting wheel already pinned to shaft.

RING INSTALLATION S251P

TO INSTALL RING: With a twisting motion drive the pointed end of a spud wrench or a tapered piece of round shaft into the closed portion of the cast iron ring as shown in the detail. This will pivot ring open far enough to allow it to slide on over the pipe. Slide ring down length of pipe and into position at 7/16" diameter holes.

TO FASTEN RING TO PIPE: Insert hex head bolt through holes in ring into square nut in recess. Tighten bolt until ring clamps down securely on pipe. Ring should be adjusted as bolt is tightened so it sits straight on pipe.

TO FASTEN CURTAIN TO RING: Position fastening section over raised boss on ring and line up holes. Insert 3/8" screw with flat washer into tapped hole and tighten down firmly.

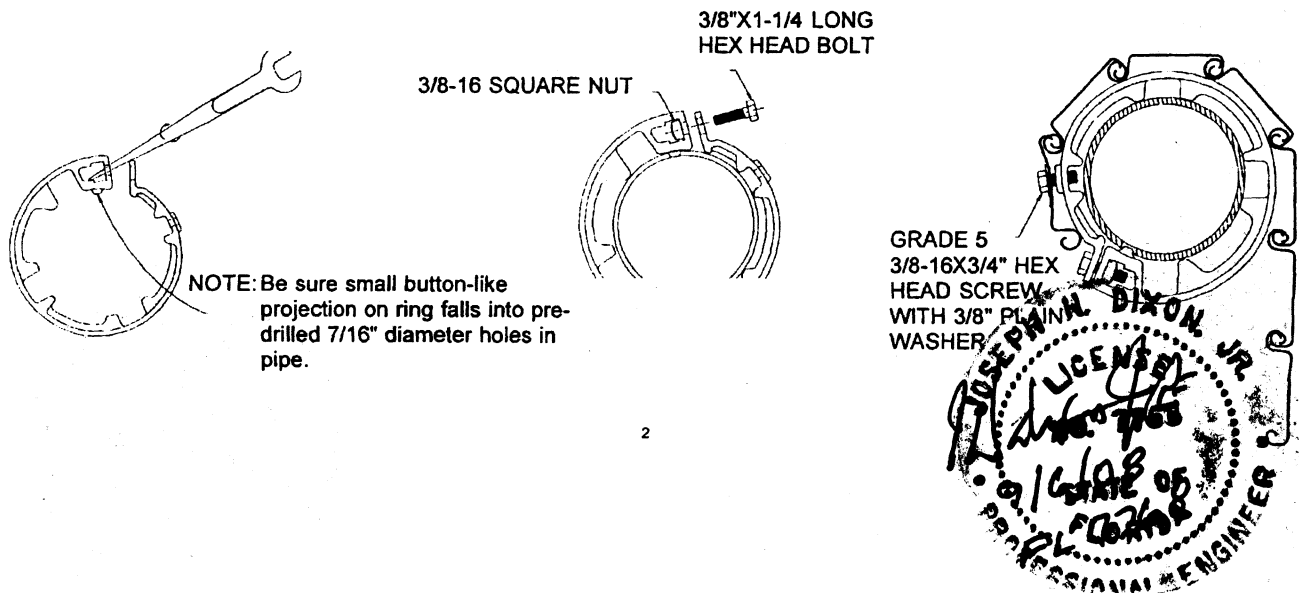

- STEP 6** Assemble operator bracket (5) on opposite end of shaft; chain and crank operators are factory mounted on brackets. It will be necessary to place sprocket (14) on the shaft as you are assembling the bracket and connect the roller chain drive.
- STEP 7** Hoist the shaft and brackets and fasten the brackets to the inside of the wall angle at top with machine bolts supplied. Note larger doors use machine bolts at top and flat head bolts in the counter sunk holes at bottom. Tighten bolts and check for level of shaft. Adjustment can be made by loosening guide fastening bolts on wall and moving entire guide assembly. On chain or crank operated doors, make final location adjustment of driven sprocket and roller chain at this time. Also, install hood support (13A), if supplied, to lintel construction.
- STEP 8** **NOTE:** Extra care should be used in this step, especially with thermiser insulated curtains to protect the finish. Position the rolled curtain (wrapping intact) on two pieces of 2"x4" blocks (2" on end) at base of guides. Be sure the end of the roll is on top and the curtain is coiled in the proper direction. Cut banding and allow wrapping to lay back. Do not remove wrapping. Drill or punch hole in center of the fourth slat down, leaving the top three slats and fastening sections free. Insert a 1/2" machine eye (not furnished) using flat washers on either side of slat. Eye should be large enough to accept hook of the chain block. On wider doors (over 10 ft.) use two eyes approximately 4 ft. on centers to distribute the weight.
- The chain from above should be behind the shaft (towards the wall). Couple hook to eye and raise curtain with chain hoist while keeping roll of curtain on cardboard wrapping as it unrolls.
- STEP 9** When the top four slats are near the shaft and equidistant from brackets, attach fastening sections to rings (8) with washers and nuts provided and crimp beads on either side of fastening section. (See **Installing Rings**).
- STEP 10** Verify the number of turns to be applied to the shaft with the curtain in the fully closed position. This information is written on the adjustor end of the pipe. Begin applying torque to the shaft (6) by inserting a proper shaped and sized bar (flat or round) approximately 2 feet long into the top most hole of the adjustor wheel (9). Pull bar down and away from the wall (rotating adjustor wheel in the curtain coiling direction) and insert adjustor pin (10) thru the bracket clip angle and into the top hole of the adjustor wheel to hold the tension applied to the shaft.
- NOTE:** Be sure to wind the adjustor wheel in the proper direction. Apply torque (rotation) in the same direction in which the curtain coils. In order to apply the full amount of spring charge required, it may be necessary to alternately raise the curtain with the hand chain (crank) operator and apply turns with the adjustor wheel. After full spring charge (torque) has been applied, raise curtain carefully to the point where the bottom bar and curtain can be positioned in the guides. Lower the curtain (now within the guides) several inches below the top of the guide.
- CAUTION:** The curtain at this point has the ability to lift and spin around on the shaft, thus losing the torque just applied. Therefore, some precaution in securing the curtain in the guides should be taken before installing the stoppers. Install removable bellmouth/stoppers on guide assemblies with self-tapping screws supplied. Re-align sprocket (14) if necessary and tighten set screws at this time.
- STEP 11** Check curtain for ease of operation. Spring tension adjustment if needed, should be added or released, as required, within the curtain fully raised.
- CAUTION:** Insert bar (From step 10) into adjustor wheel (9). Relieve tension on adjustor pin (10) and remove. Turn wheel one notch at a time replacing adjustor pin at intervals. To increase tension rotate wheel in direction of raising curtain. To decrease, wheel will rotate under its own power in direction of lowering curtain.
- STEP 12** Place sheet metal hood (13) on end brackets and align. Attach with sheet metal screws provided. On hoods with more than one section a hood support (13A) is supplied. The support is centered between the end brackets (Ref. Step 7). If more than one hood support is supplied the locations should be checked relative to length of hood sections supplied, working from one end to the opposite end.

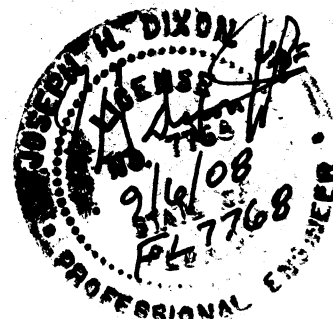

ROLLING STEEL DOORS

(Thermiser, Service and Weathered)

Motor Operated Doors Are Operating Correctly When:

- Door runs to full open position and shuts off without slamming against upper guide stops.
- Door runs to full closed position and stops without buckling; bottom bar should make adequate contact with the floor.
- Safety bottom edge stops or reverses door travel when tested as door is closing.
- Functions of all control stations work properly (open, close, and stop).
- Door does not drift more than 6 in. when stop button is depressed while door is closing and at middle of travel.
- Door operates full cycle without catching or binding.
- Door is level in open and closed position.
- Emergency hand chain on operator raises and lowers door adequately (use only in emergencies; do not run door for long periods through the emergency hand chain).
- Emergency disconnect on operators allows door to be manually raised or lowered.

Manual Doors Are Operating Correctly When:

- Door stays open without drifting down.
- Door balances in closed position or has slight lift.
- Door operates without excessive force to lift (less than 25 pounds).
- Door operates full cycle without catching or binding.
- Door is level in full-open and full-closed position.
- No excessive component wear exists.

SUGGESTED LUBRICANTS	
To Lubricate:	Use:
Roller Chains	Roller chain lubricant with penetrating agent. Available in spray cans.
Spur Gears	Open gear lube designed for spur gears having a tacky consistency. Available in spray cans.
Wear Points on Guides, End Brackets, also for Endlocks.	Parafin based lubricant in stick form or spray dry graphite lubricant.
Bearings with Grease Fittings.	Multi purpose grease.
Lock Mechanisms, and Stub Shafts	General purpose lubricant in spray form.

DOOR MAINTENANCE STEPS

Improper maintenance procedures can damage a good door and injure the technician doing the work. The "Door Maintenance Steps" lists recommended procedures for keeping a door performing at its maximum.

1. Inspect door for alignment, level, and proper working clearances.
2. Check curtain for damaged, loose, or missing endlocks.
3. Check guides for damage and secure attachment.
4. Inspect upper guide stops for damage, proper alignment, and secure attachment.
5. Inspect guide, head, and bottom bar weatherstripping for wear or damage.
6. Examine curtain to shaft attachment.
7. Inspect end brackets for secure attachment. Check inside of end brackets for curtain rubbing. Adjust curtain and lubricate wear points on bracket.
8. Test the operation of the door for proper spring balance (on motor operated doors use emergency hand chain operator to test balance). When the door has proper balance, the curtain should have lift at the stops in the open position and not drift down. At the floor, the curtain should be balanced or lift up slightly. The door should not be difficult to raise through the middle of travel. The door may run through the middle of travel.
9. Lubricate roller bearings which have grease fittings. Bearings are located at the operator end bracket and at adjuster end of pipe shaft.
10. Operate the door while closely watching curtain movement, correct any deficiencies which may cause the door to catch or snag.
11. Inspect, align and lubricate the chains, stub shafts and gears of manual chain hoists or crank operators. Tighten all set screws and check roller chain tension.
12. Inspect hand operating chain, crank eye, and removable crank for damage or wear.
13. Check spring adjusting wheel and keeper for damage and secure installation.
14. Check hood for secure attachment.
15. Check operation of locks or slide bolts. Tighten cylinder locking set screws and lubricate the lock mechanism.

For motor operated doors refer to the motor maintenance section.

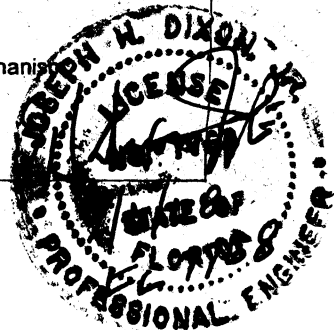

INSTALLING MOTOR OPERATORS

On door guides mounted to steel, angle is supplied with pre-drilled tapped holes matching the motor base plate. Drill and insert expansion shields. Hoist and bolt motor in place. Fit and align chain around sprockets. Cut chain to size (with a chain breaker if available). Adjust for correct chain tension and tighten bolts securely. It is important to use the lock washers supplied. On doors mounted to masonry, the holes for the inboard side of the base plate are pre-drilled and tapped in the leg of the wall angle. Duplicate layout for the outboard holes. Operator must be mounted securely to prevent movement during operation. Additional bracing may be required to meet field conditions. For special motor mountings refer to additional instructions provided (Ref. Vertical Bracket Mounting) or refer to shop drawings.

NOTE: Bracket mount and some wall mount operators require "outboard" bracing from motor plate to nearby construction. Refer to shop drawings for arrangement required using brace angles and hardware supplied.

VERTICAL BRACKET MOUNTING M26A

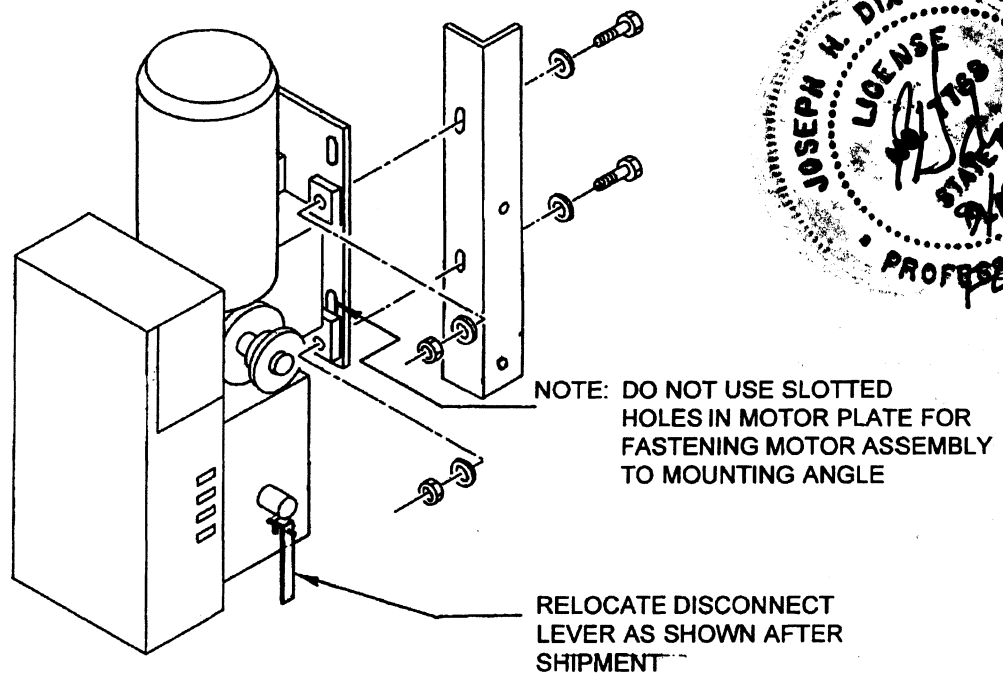

NOTE: Motor assembly is shipped ready to be installed with mounting members and brackets pre-drilled, all necessary hardware and correct length of roller chain required. Follow these instructions carefully for correct mounting of motor operator.

- STEP 1** Remove the bolts, from the drive side only of the motor assembly, which fasten the reducer to the motor plate.
- STEP 2** Line up slots in motor mounting angle with holes through reducer feet and motor plate as shown in sketch. The top of the mounting angle should line up with the top of the motor plate. Fasten through all three of these with 3/8-16x2" long hex head bolt using a washer on either side and one 3/8-16 hex nut. (These fasteners are shipped with the motor mounting angle.)
- STEP 3** Hoist motor and fasten motor mounting angle to outside of bracket plate through holes provided.
- STEP 4** Install motor bracing angle (will have clip angles bolted to either end). One end of brace to be fastened to unsupported side of motor through the slot at the top of the motor plate, the other end to be fastened to bracket plate, guide support member or any other convenient rigid member.
- STEP 5** Align drive and driven sprockets on motor and coil shaft, tighten set screws and install roller chain provided.

MOTOR OPERATOR MAINTENANCE

Operators require practically no special maintenance other than periodic checking to see that mechanical parts where necessary are lubricated and the electrical compartments are clear of dirt.

Service technician should first familiarize himself with proper sequence of operation of operator and all related controls. Power to operator must be shut off when removing or replacing covers on electrical components, making adjustments, or performing maintenance.



1. Check wire connections for tightness and wire insulation for defects of abrasions.
2. Check to see that all conduit connections are secure.
3. Check wires to safety edge if unit is equipped with a safety to reverse feature.
4. Inspect, align and adjust V-belt. (belt operator)
5. Check pulley clutch mechanism for slippage. (belt operator)
6. Inspect operation of brake. (gear operator)
7. Inspect gearbox for leaks. (gear operator)
8. Inspect roller chain and drive sprockets. Align, lubricate the sprockets and tighten the set screws. Adjust chain tension.
9. Generally inspect the motor mounting, and tighten the fasteners and bracing.
10. Test the operation of the emergency disconnect or hand chain mechanisms and lubrication the friction points.
11. Check the disconnect cutoff switch for correct mechanical and electrical operation.
12. Verify that all conduit connections are tight and have no exposed wires.
13. Inspect the wiring panel for debris, arching or moisture. Check for and tighten loose wiring connections.
14. Test motor operation through all control stations.
15. Check limit switch setting.
16. Examine safety edge, coil cord and take up reel for damage.
17. Test the operation of the safety edge.
18. Check motor amperage draw for a full open and close cycle. Compare readings to those listed on the amperage table.
19. Inspect and test track mounted lock cutout switches for correct mechanical and electrical operation.



OPERATORS TROUBLE SHOOTING GUIDE

SYMPTOM	POSSIBLE CAUSE	CURE
Motor does not run when OPEN or CLOSE button is pushed.	Circuit breaker tripped or power fuse blown.	Check circuit breaker, power fuses, safety switch; check cause.
	Thermal overload tripped.	Reset; check cause.
	Manual interlock switch open. (on units with emergency operator)	Shift into MOTOR operation.
	Note: Operate contact on start by hand. If motor runs, cause is in control circuit.	Check pushbutton wires. Check wiring to the manual interlock.
	External interlock open. (if supplied)	Close interlocks.
Motor runs but door does not move.	Sprocket key missing or drive chain broken.	Check drive train for operation.
	Clutch slipping. (if furnished)	Adjust clutch.
Motor hums but does not run.	Door jammed. Drive train jammed.	Check door. Try to operate manually.
	Dead phase in 3 phase system.	Check power supply.
	Brake does not release.	Check power to brake solenoid.
	Open motor winding.	Check all motor connections.
Operator runs in wrong direction and limits do not function.	On 3 phase operators power supply is out of phase.	Interchange any 2 power leads to unit.
	Note: All units are checked for proper rotation at factory. Limit switch adjustment instructions in limit housing indicates proper direction of travel for OPEN and CLOSE limit nuts.	
Limit switches do not hold their setting.	Drive chain loose allows chain to jump sprocket teeth.	Adjust chain to proper tension.
	Limit nut retainer not engaging slots in limit nuts.	Be sure retainer is in slots of BOTH nuts.
	Limit nuts binding on screw threads which allows them to jump position on retainer.	Lubricate screw thread. Limit nuts should turn freely.
Door 'drifts' when motor shuts off.	Brake inoperative or improperly adjusted.	Check brake operation. Check solenoid.
Operator does not shut off at full OPEN or at full CLOSE position.	Limit nuts not properly adjusted.	Adjust. (see above)
	Sprocket on limit shaft loose or limit drive chain broken.	Tighten set screw. Replace chain.
	Defective limit switch.	Operate limit switch manually to determine.

