



GULFRIB™

29 GAUGE GULFRIB™ PANEL OVER 1X4 WOOD PURLINS
FLORIDA PRODUCT APPROVAL NO. 11651.27 R2

Product Evaluation Report
GULF COAST SUPPLY & MANUFACTURING, LLC.

29 Ga. GulfRib™ Roof Panel over 1x4 Wood Purlins

Florida Product Approval #11651.27 R2

Florida Building Code 2014
Per Rule 61G20-3
Method: 1 –D

Category: Roofing
Subcategory: Metal Roofing
Compliance Method: 61G20-3.005(1)(d)
NON HVHZ

Product Manufacturer:
Gulf Coast Supply & Manufacturing, LLC.
14429 SW 2nd Place, Suite G30
Newberry, FL 32669

Engineer Evaluator:
Dan Kuhn, P.E. #75519
Florida Evaluation ANE ID: 10743

Validator:
Locke Bowden, P.E. #49704
9450 Alysbury Place
Montgomery, AL 36117

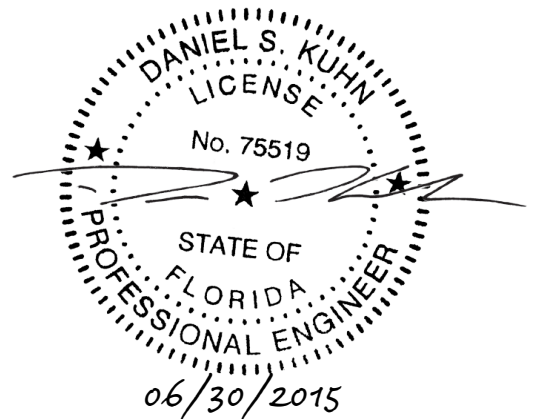

Contents:
Evaluation Report Pages 1 – 5





GULFRIB™

29 GAUGE GULFRIB™ PANEL OVER 1X4 WOOD PURLINS
FLORIDA PRODUCT APPROVAL **NO. 11651.27 R2**

- Compliance Statement:** The product as described in this report has demonstrated compliance with the Florida Building Code 2014, Sections 1504.3.2, 1504.7.
- Product Description:** GulfRib™, ¾" Rib Roof Panel, Minimum 29 Ga. Steel, 36" Coverage, through fastened roof panel over Minimum 1x4 Wood Purlins over one layer of Asphalt Shingles (optional) over minimum ¾" OSB or minimum 1½" Plywood Decking. Non Structural application.
- Panel Material/Standards:** Material: Minimum 29 Ga. Steel, ASTM A792 or ASTM A653 G90 conforming to Florida Building Code 2014 Section 1507.4.3.
Paint Finish Optional
Yield Strength: Min. 102.0ksi
Corrosion Resistance: Panel Material shall comply with Florida Building Code 2014, Section 1507.4.3.
- Panel Dimension(s):** Thickness: 0.0142" Minimum
Width: 36" Coverage
Rib Height: ¾" Major Rib at 9" O.C.
- Panel Fastener:** #9-15x1.5" HWH with sealing washing or approved equal
¼" minimum penetration through plywood.
Corrosion Resistance: Per Florida Building Code 2014, Section 1506.6, 1507.4.4
- Substrate Description:** Minimum 1x4 No. 2 SYP wood purlins over maximum one layer of asphalt shingles (optional) over min. ¾" OSB or min. 1½" thick over supports at maximum 24" O.C. The 1x4 wood purlins shall be fastened to the wood rafters (24" O.C. Max) with (2) 9 x 2½" Deck Screws per rafter (Minimum 1⅞" penetration into wood rafter). Design of 1x4 wood purlins, OSB, plywood and OSB/plywood supports are outside the scope of this evaluation. Must be designed in accordance w/ Florida Building Code 2014.

Design Uplift Pressures:

Table "A"	
Maximum Total Uplift Design Pressure	101.0 psf
Fastener Pattern	9"-9"-9"-9"
Fastener Pattern Spacing	24" O.C.
Design Pressure includes a Safety Factor = 2.0.	





GULFRIB™

29 GAUGE GULFRIB™ PANEL OVER 1X4 WOOD PURLINS
FLORIDA PRODUCT APPROVAL NO. 11651.27 R2

Code Compliance:	The product described herein has demonstrated compliance with the Florida Building Code 2014, Sections 1504.3.2, 1504.7.
Evaluation Report Scope:	The product evaluation is limited to compliance with the structural wind load requirements of the Florida Building Code 2014, as relates to Rule 61G20-3.
Performance Standards:	The product described herein has demonstrated compliance with: <ul style="list-style-type: none">• UL 580-06 - Test for Uplift Resistance of Roof Assemblies• UL 1897-04 - Uplift Test for Roof Covering Systems.• FM 4471-1992, Section 4.4 Foot Traffic Resistance Test
Reference Data:	<ol style="list-style-type: none">1. UL 580-94 / 1897-98 Uplift Test Force Engineering & Testing, Inc. (FBC Organization # TST-5328) Report No. 117-0407T-09, Dated 11/16/092. FM 4471-95, Section 4.4 Foot Traffic Resistance Test Force Engineering & Testing, Inc. (FBC Organization # TST-5328) Report No. 117-0238T-09E, Dated 07/21/20093. Certificate of Independence By Dan Kuhn, P.E. (FL# 75519) @ Kuhn Engineering, LLC (FBC Organization # ANE ID: 10743)
Test Standard Equivalence:	<ol style="list-style-type: none">1. The UL 580-94 test standard is equivalent to the UL 580-06 test standard.2. The UL 1897-98 test standard is equivalent to the UL 1897-04 test standard.3. The FM 4471-95 test standard is equivalent to the FM 4471-1992 test standard.
Quality Assurance Entity:	The manufacturer has established compliance of roof panel products in accordance with the Florida Building Code and Rule 61G20-3.005(3) for manufacturing under a quality assurance program audited by an approved quality assurance entity.
Minimum Slope Range:	Minimum Slope shall comply with Florida Building Code 2014, including Section 1507.4.2 and in accordance with Manufacturers recommendations. For slopes less than 3:12, lap sealant must be used in the panel side laps.
Installation:	Install per Manufacturer's recommended details.
Underlayment:	Shall comply with Florida Building Code 2014 section 1507.4.5.1 and 1507.4.5.2.

FL# 11651.27 R2 • JUNE 15, 2015

PRODUCT EVALUATION REPORT





GULFRIB™

29 GAUGE GULFRIB™ PANEL OVER 1X4 WOOD PURLINS
FLORIDA PRODUCT APPROVAL NO. 11651.27 R2

Roof Panel Fire Classification: Fire classification is not part of this acceptance.

Shear Diaphragm: Shear Diaphragm values are outside the scope of this report.

Design Procedure: For roofs within the parameters listed on the load table, fastening pattern must at a minimum meet those listed for the applicable wind zone. For all roofs outside the parameters listed on the load table, design wind loads shall be determined for each project in accordance with FBC 2014 Section 1609 or ASCE 7-10 using allowable stress design. The maximum fastener spacing listed herein shall not be exceeded. This evaluation report is not applicable in High Velocity Hurricane Zone. Refer to current NOA or HVHZ evaluation report for use of this product in High Velocity Hurricane Zone.





GULFRIB™

29 GAUGE GULFRIB™ PANEL OVER 1X4 WOOD PURLINS
FLORIDA PRODUCT APPROVAL NO. 11651.27 R2

ENGINEER LOAD TABLE: 29 Ga. GulFRib™ Panel over 1x4 Wood Purlins

Buildings having a Roof Mean Height $\leq 20'-0"$; Roof Slope: $2"/12"$ - $12"/12"$ Gable or Hip Roof; Wind Speeds 120-170mph, Exposure C, Risk Category II, Enclosed Building, based on Florida Building Code 2014.

WIND SPEED	FASTENER (MIN. 1/4" Penetration)	SUBSTRATE	120	130	140	150	160	170
			ON CENTER SPACING	ON CENTER SPACING	ON CENTER SPACING	ON CENTER SPACING	ON CENTER SPACING	ON CENTER SPACING
ZONE 1	#9-15x1.5"	1x4 Wood Purlins	24"	24"	24"	24"	24"	24"
ZONE 2	#9-15x1.5"	1x4 Wood Purlins	24"	24"	24"	24"	24"	24"
ZONE 3	#9-15x1.5"	1x4 Wood Purlins	24"	24"	24"	24"	24"	24"

- PANEL DESCRIPTION:** GULFRIB™, MIN. 29 GA., GRADE 102, 36" COVERAGE, 3/4" TALL.
- PANEL FASTENER:** #9-15X1.5" HWH WITH SEALING WASHER OR APPROVED EQUAL
- MAXIMUM ALLOWABLE PANEL UPLIFT PRESSURE:** 101.0 PSF @ 24" O.C. FASTENER SPACING BASED ON TAS 125, UL 580/UL 1897 TESTING.
- SUBSTRATE:** 1X4 WOOD PURLINS OVER MAX. ONE LAYER OF ASPHALT SHINGLES (OPTIONAL) OVER MIN. 7/16" OSB OR MIN. 1 1/2" THICK PLYWOOD. WOOD PURLINS ATTACHED TO WOOD RAFTER (24" O.C. MAX) WITH (2) 9 X 2 1/2" DECK SCREWS WITH MIN. 1 7/8" PENETRATION INTO WOOD RAFTERS. PURLINS, OSB AND PLYWOOD MUST BE DESIGNED IN ACCORDANCE WITH FBC 2014
- ROOF SLOPE:** ON ROOF SLOPES LESS THAN 3:12, LAP SEALANT MUST BE USED IN PANEL SIDE LAPS.
- LOAD TABLE** BASED ON WIND PRESSURES CALCULATED PER ASCE 7-10 (KD = 0.85) MULTIPLIED BY 0.6 PER FLORIDA BUILDING CODE 2014

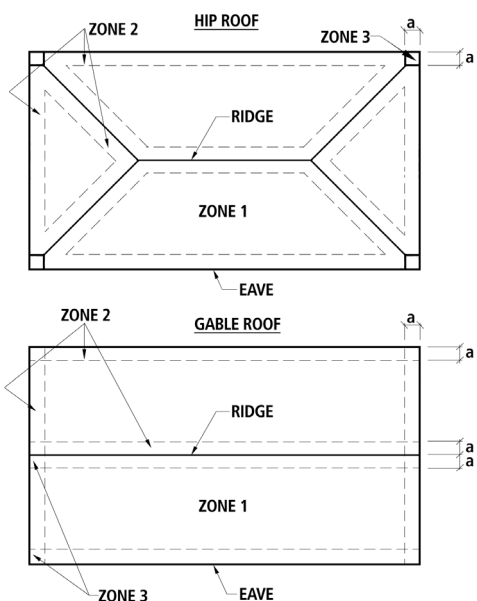

Note: Dimension (a) is defined as 10% of the minimum width of the building or 40% of the mean height of the roof, whichever is smaller, however, (a) cannot be less than either 4% of the minimum width of the building or 3 feet.

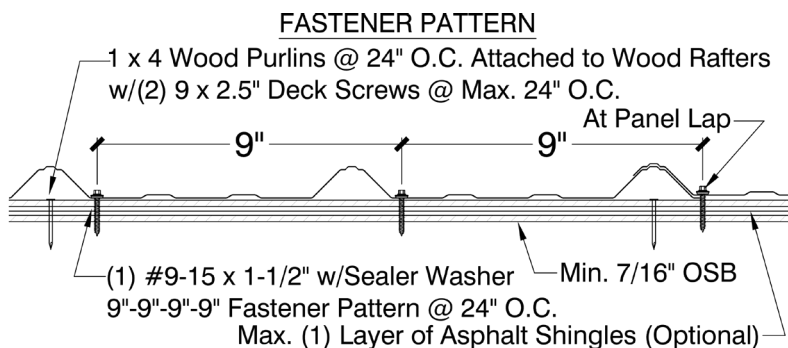

FL# 11651.27 R2 • JUNE 15, 2015

PRODUCT EVALUATION REPORT



KUHN ENGINEERING, LLC

11670 ISLAND LAKES LANE, BOCA RATON, FL 33498 • FL COA #30464