

Evaluation Report "Cee-Lock Panel" Metal Roof Assembly

Manufacturer:

Berridge Manufacturing Company

**1720 Maury Road
Houston, TX 77026
(800) 231-8127**

for

Florida Product Approval

FL 11269.4 R7

Florida Building Code 7th Edition (2020)

Method: 1 - D

Category: Roofing

Sub - Category: Metal Roofing

Product: Cee-Lock" Roof Panel

Material: Aluminum

Panel Thickness: 0.032"

Panel Width: 16.5"

Support: Steel Deck

Prepared by:

James L. Buckner, P.E., S.E.C.B.

Florida Professional Engineer # 31242

Florida Evaluation ANE ID: 1916

Project Manager: Diana Galloway

Report No. 20-227-CL-A3S-ER

(Revises 17-128-CL-A3S-ER, FL11269.4 R5)

Date: 09 / 17 / 20

Contents:

Evaluation Report

Pages 1 – 8

This item has been electronically signed and sealed by James L. Buckner, P.E., on this date using a Digital Signature. Printed copies of this document are not considered signed and sealed, and the signature must be verified on any electronic copies.

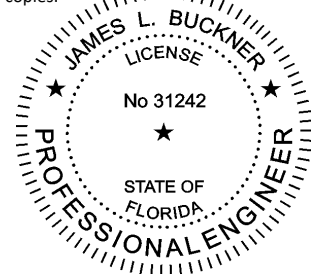

2020.09.17 13:23:17 -04'00'

CBUCK, Inc. dba CBUCK Engineering

Phone: (561) 491-9927 · Email: cbuck@cbuckinc.net · Website: www.cbuckinc.net

Business: 1374 Community Dr., Jupiter, FL 33458 · Corp/Mailing: 2637 E. Atlantic Blvd, #34069, Pompano Beach, FL 33062

Manufacturer:	Berridge Manufacturing Company
Product Name:	“Cee-Lock”
Product Category:	Roofing
Product Sub-Category	Metal Roofing
Compliance Method:	State Product Approval Rule 61G20-3.005 (1) (d)
Product/System Description:	“Cee-Lock” Snap-Lock Roof Panel 1-1/2” Rib Height, 16.5” wide, 0.032” Aluminum roof panel restrained by panel clips fastened into Steel Deck.
Product Assembly as Evaluated:	Refer to Page 4 of this report for product assembly components/materials & standards: <ol style="list-style-type: none">1. Roof Panel2. Panel Clip3. Fasteners4. Underlayment5. Insulation
Support:	Type: Steel Deck (Design of support and its attachment to support framing is outside the scope of this evaluation.) Description: <ul style="list-style-type: none">• 22 gauge (min.)• Yield Strength: 40 ksi minimum
Slope:	Minimum slope shall be in compliance with FBC Chapter 15 Section 1507.4.2, applicable code sections and in accordance with manufacturer’s recommendations.
Performance:	Wind Uplift Resistance: <ul style="list-style-type: none">• Design Uplift Pressure: Refer to Table A (Refer to “Table A” attachment details herein)

- Performance Standards:** The product described herein has demonstrated compliance with:
- UL580-06 – *Test for Uplift Resistance of Roof Assemblies*
 - UL 1897-12 – *Uplift test for roof covering systems*
 - TAS 125-03 – *Standard Requirements for Metal Roofing Systems*
- Code Compliance:** The product described herein has demonstrated compliance with Florida Building Code 7th Edition (2020), Section 1504.3.2.
- Standards Equivalency:** The UL 580-94 & UL 1897-98 standard version used to test the applicable evaluated product assemb(ies) are equivalent with the prescribed standards in UL 580-06 & UL 1897-12 adopted by the Florida Building Code 7th Edition (2020).
- Evaluation Report Scope:** This product evaluation is limited to compliance with the structural requirements of the Florida Building Code, as related to the scope section to Florida Product Approval Rule 61G20-3.001.
- Limitations and Conditions of Use:**
- Scope of “Limitations and Conditions of Use” for this evaluation:
This evaluation report for “Optional Statewide Approval” contains technical documentation, specifications and installation method(s) which include “Limitations and Conditions of Use” throughout the report in accordance with Rule 61G20-3.005. Per Rule 61G20-3.004, the Florida Building Commission is the authority to approve products under “Optional Statewide Approval”.
 - Option for application outside “Limitations and Conditions of Use”
Rule 61G20-3.005(1)(e) allows engineering analysis for “project specific approval by the local authorities having jurisdiction in accordance with the alternate methods and materials authorized in the Code”. Any modification of the product as evaluated in this report and approved by the Florida Building Commission is outside the scope of this evaluation and will be the responsibility of others.
 - Design of support system is outside the scope of this report.
 - Fire Classification is outside the scope of Rule 61G20-3, and is therefore not included in this evaluation.
 - This evaluation report does not evaluate the use of this product for use in the High Velocity Hurricane Zone code section. (Dade & Broward Counties)
- Quality Assurance:** The manufacturer has demonstrated compliance of roof panel products in accordance with the Florida Building Code and Rule 61G20-3.0005 (3) for manufacturing under a quality assurance program audited by an approved quality assurance entity through UL, LLC (FBC Organization #: QUA 9625).

**Components/Materials
(by Manufacturer):**

Roof Panel: Berridge "Cee-Lock"
Material: Aluminum
Thickness: 0.032" (min.)
Panel Width: 16.5" (max.) Coverage
Rib Height: 1-1/2"
Yield Strength: 24 ksi min.
Alloy Type: 3105-H14
Corrosion Resistance: In compliance with FBC Section 1507.4.3:
ASTM B209

Roof Panel Clips: Berridge "Cee-Clip"
Type: One-Piece, fixed clip
Material: Stainless Steel
Thickness: 24 Gauge
Dimensions: 1-15/16" (tall) x 1-3/8" (wide) x 3-1/2" (long)
Yield Strength: 40 ksi min.
Corrosion Resistance: Per FBC Section 1506.7

Fastener:
Type: Low profile Self-Drilling Screws with steel disc
Size : #14 – 13 x 9" with 3" diameter steel disc
Corrosion Resistance: Per FBC Section 1504.4 and 1506.6
Standard: Per FBC Section 1506.6

Bearing Plate:
Material: Galvanized Steel
Size: 6" x 6"
Thickness: 24 gauge
Yield Strength: 40 ksi min.

**Components& Materials:
(by Others)**

Underlayment:
Material and application shall be in compliance with FBC Section 1507.1.1 and in accordance with applicable code sections and manufacturer's recommendations.

Insulation (Optional):
Type: Rigid Insulation Board
Thickness: 4" – 6" (max.)
Properties:
Density: 2.25 pcf (lbs/ft³) min.
Or Compressive Strength: 20 psi min.

Insulation Notes:

- Rigid Insulation shall meet minimum density OR compressive strength.
- Insulation shall comply with FBC Section 1508. When insulation is incorporated, fastener length shall conform to penetrate thru bottom of support a minimum of 3/4".

Installation:

Installation Method:

(Refer to "TABLE A" below and drawings at the end of this report.)

- Clip Spacing:
 Refer to "TABLE A" Below (along the length of the panel)
- Rib Interlock: Snap-Lock
 (Panel ribs shall be fully engaged to form an integral snap-lock.)
- Minimum fastener penetration thru bottom of support, 3/4".
 (through bottom flute of steel deck)
- For panel construction at the end of panels, refer to manufacturer's instructions and any site specific design.

TABLE "A"						
ALLOWABLE LOADS						
#	Deck Thickness	Panel Clip	Fastener w/3" disk	# Fasteners per Clip	Clip Spacing	Design Pressure
1	22 ga. min.	Cee-Clip	#14	2	20"	- 71 PSF
2	22 ga. min.	Cee-Clip	#14	2	12"	- 116 PSF
<ul style="list-style-type: none"> • Allowable design pressure(s) for allowable stress design (ASD). 						

Install the "Cee-Lock" roof panel assembly in compliance with the installation method listed in this report and applicable code sections of FBC 7th Edition (2020). The installation method described herein is in accordance with the scope of this evaluation report. Refer to manufacturer's installation instructions as a supplemental guide for attachment.

Referenced Data:

1. TAS 125-03 Uplift Test (Per UL580-06 and UL 1897-04)
 By Force Engineering & Testing Inc.(FBC Organization #TST ID: 5328)
 Report #: 49-0212T-13A,B, Test Date: 10/22/13
2. Quality Assurance
 UL, LLC (FBC Organization #: QUA 9625)
3. Certification of Independence
 By James L. Buckner, P.E. @ CBUCK Engineering
 (FBC Organization # ANE 1916)

Installation Method
Berridge Manufacturing Company
"Cee-Lock" (0.032" Aluminum) Roof Panel attached to Steel Deck

Drawings

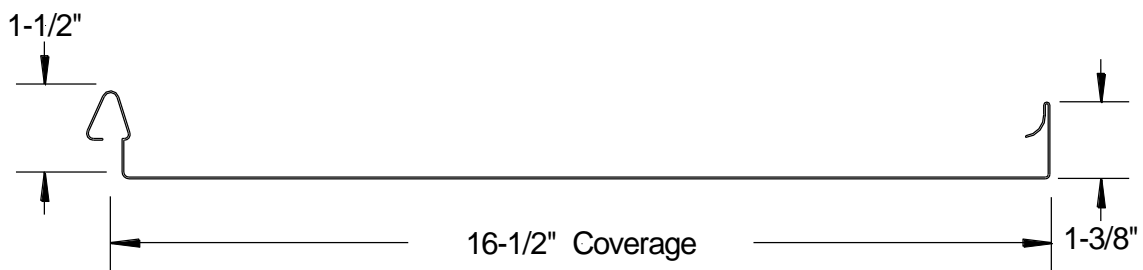

Typical Panel Profile

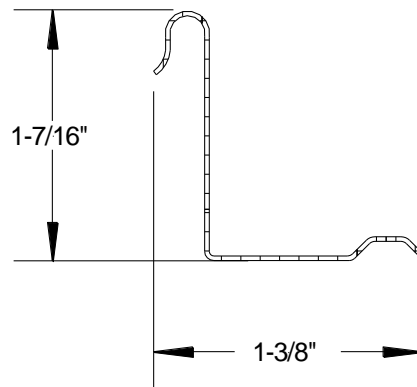

Berridge "Cee-Clip"
Panel Clip Profile Side View

Installation Method Berridge Manufacturing Company "Cee-Lock" (0.032" Aluminum) Roof Panel attached to Steel Deck

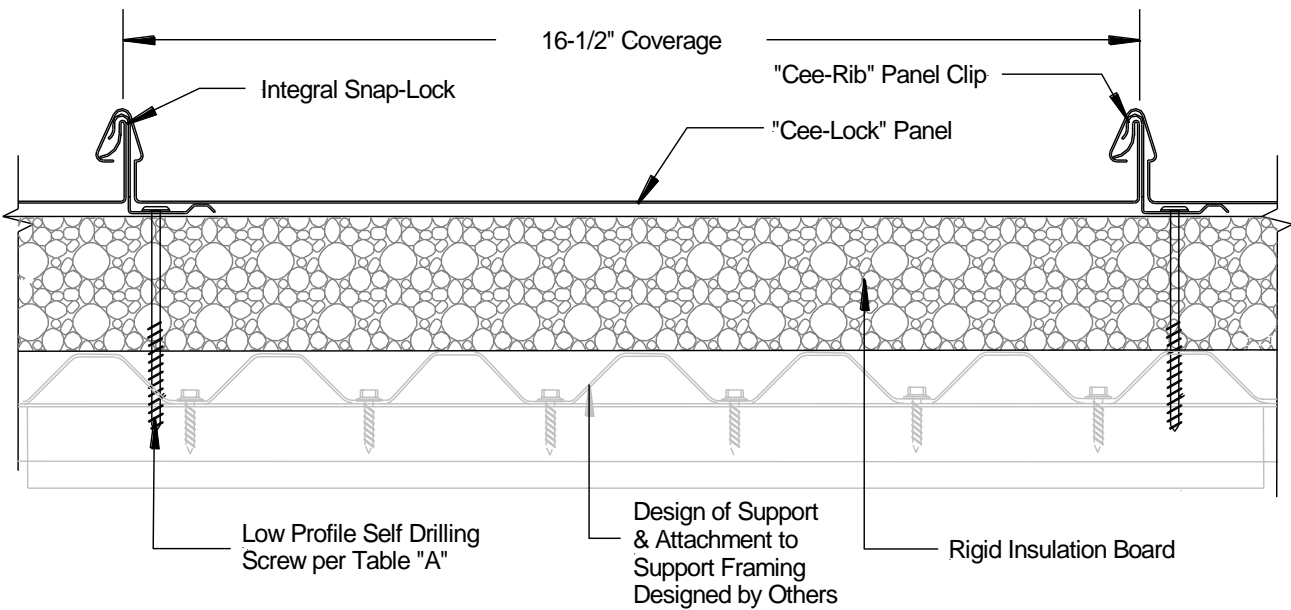

**Typical Assembly Profile View
 (Typical Fastening Pattern Across Width)**

TABLE "A"						
#	Deck Thickness	Panel Clip	Fastener w/3" disk	# Fasteners per Clip	Clip Spacing	Design Pressure
1	22 ga. min.	Cee-Clip	#14	2	20"	- 71 PSF
2	22 ga. min.	Cee-Clip	#14	2	12"	- 116 PSF

Installation Method Berridge Manufacturing Company "Cee-Lock" (0.032" Aluminum) Roof Panel attached to Steel Deck

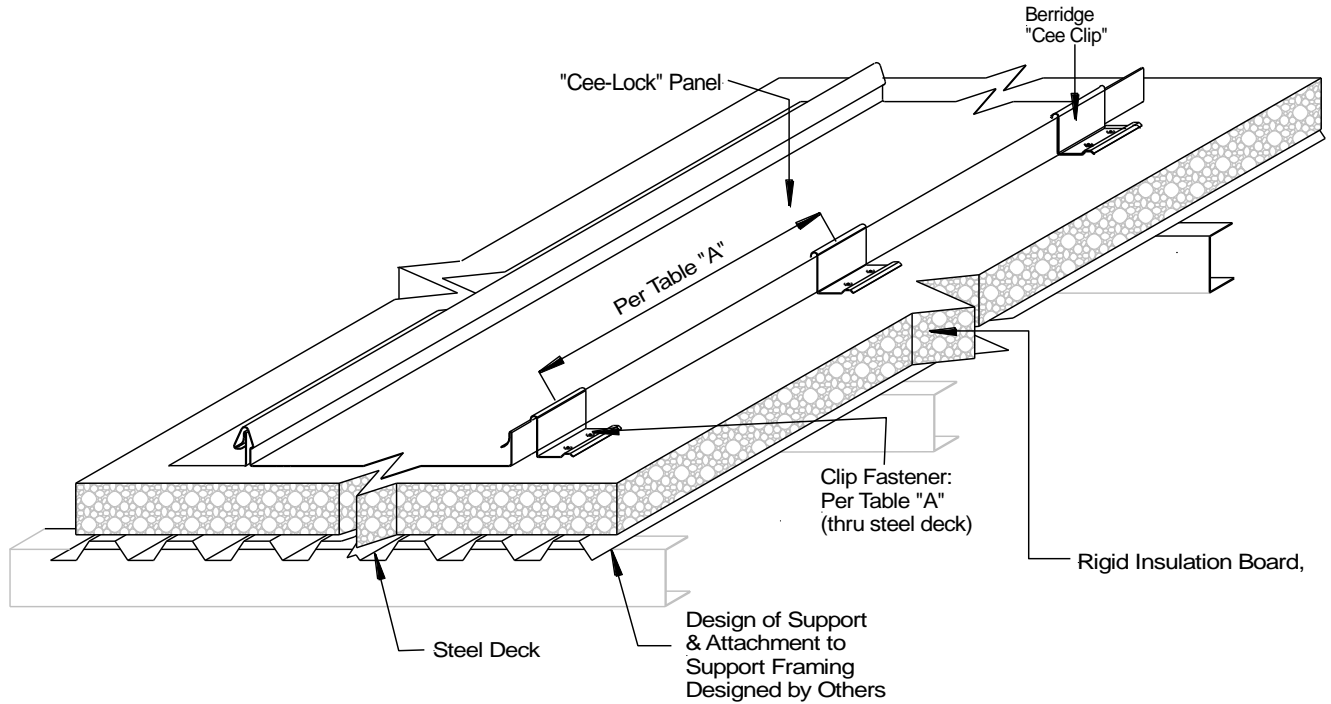

**Typical Roof Assembly
 Isometric View**

TABLE "A"						
#	Deck Thickness	Panel Clip	Fastener w/3" disk	# Fasteners per Clip	Clip Spacing	Design Pressure
1	22 ga. min.	Cee-Clip	#14	2	20"	- 71 PSF
2	22 ga. min.	Cee-Clip	#14	2	12"	- 116 PSF