

Florida Building Code, 5th Edition (2014) Fenestration Mitigation Advanced Class Online

Florida AIA

Instructor ... Jim Heise

jheise@pgtindustries.com

(941) 343-7122 (Cell)

Copyright Materials

This presentation is protected by U.S. and International Copyright laws. Reproduction, distribution, display and use of the presentation without written permission of the speaker is prohibited.

© FLORIDA AIA 2015



AIA Continuing Education

“AIA Florida” is a Registered Provider with The American Institute of Architects Continuing Education Systems. Credit earned on completion of this program will be reported to CES Records for AIA members. Certificates of Completion for non-AIA members are available on request.

This program is registered with the AIA/CES for continuing professional education. As such, it does not include content that may be deemed or construed to be an approval or endorsement by the AIA of any material of construction or any method or manner of handling, using, distributing, or dealing in any material or product. Questions related to specific materials, methods, and services will be addressed at the conclusion of this presentation.



Objective ...

To provide an understanding of the Mitigation options & codes available within the Florida Building Code, 5th Edition (2014) as it relates to fenestration.

Florida Building Code 5th Edition (2014)



5th Edition (2014) Florida Building Code: Building



5th Edition (2014) Florida Building Code: Residential



5th Edition (2014) Florida Building Code: Existing Building



5th Edition (2014) Florida Building Code: Energy Conservation

FBC Update, 5th Edition (2014)

- Uses 2012 ICC as its Base Code as required by Florida Legislature ...
- Causing sections to be changed
- Books are even larger due to sections referring to things like *seismic* and *snow loads* are no longer eliminated
- Residential & Commercial Energy Codes are totally separated within the same book

Swing Door

A Typical Example of a Florida Specific Amendment ...

- Mod 5415 allows for ***outward*** swing door over step for residential use
- Supported by the Florida Home Builders Association

Legislature

- The Legislature passed provisions to delay three elements of the 5th edition Florida Building Code for one year (until June 30, 2016), which are mandatory blower door testing, new mechanical ventilation requirements, and the secondary fire elevator for high-rises.
- Governor Scott signed budget line item 2250 that provides a study on the economic and health impacts of complying with these provisions

Agenda

- Mitigation Basics
- Reasons for Opening Protection
- Testing & Label Requirements
- Wind-borne Debris Protection
- Relevant Florida Building Codes
- NOA's & Florida Product Approvals
- Energy Changes
- Resources

Mitigation Basics

Mitigation Basics

Definition:

1. The act of mitigating, or lessening the force or intensity of something unpleasant, as wrath, pain, grief, or extreme circumstances.
2. The act of making a condition or consequence less severe.
3. The process of becoming milder, gentler, or less severe.

Mitigation Basics

According to FEMA ...

“For every \$1 spent on mitigation, \$4 in post storm cleanup and rebuilding is saved!”

While mitigation will never eliminate the risk to homeowners, it will reduce loss, and in many cases save a families home.

Reasons for Opening
Protection



**Insurance
Institute for
Business &
Home
Safety**

61 Year History of Hurricane Strikes

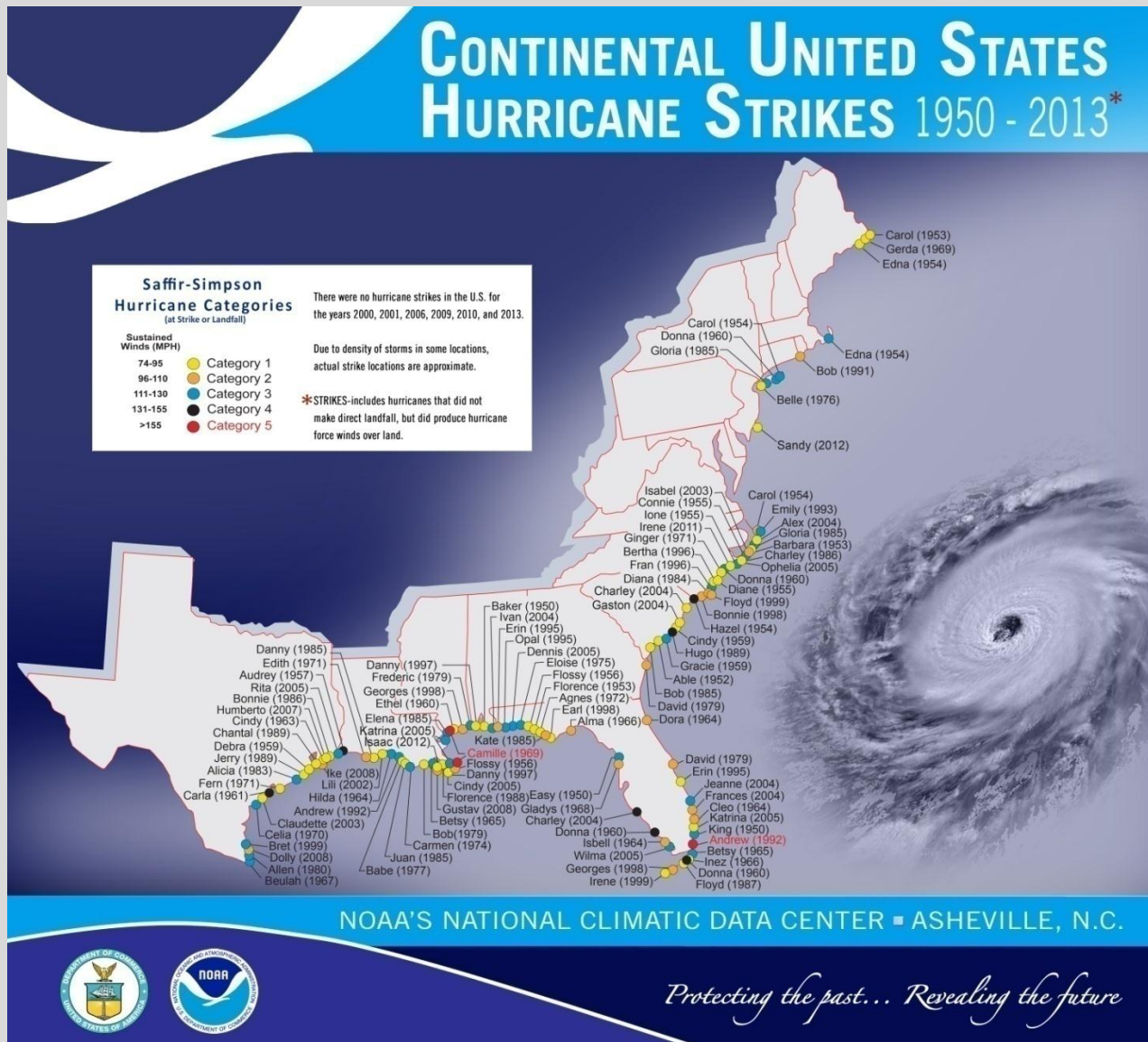

Earthquake Devastation



January 2010

Haiti Earthquake

- 7.0 magnitude
- 280,000 buildings destroyed
- **More than 200,000 deaths**

Improved Building Codes



February 2010

Chile Earthquake

- 8.8 magnitude
- 500 times stronger than the Haiti earthquake
- 500,000 buildings destroyed
- **More than 795 deaths**

Landfall Frequency



Positive & Negative Design Pressures

Positive Design Pressures

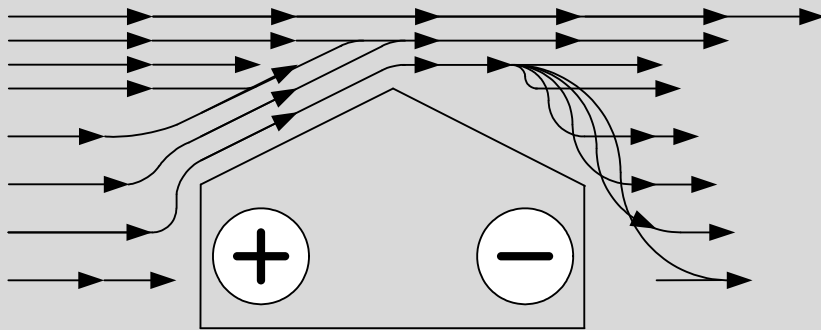
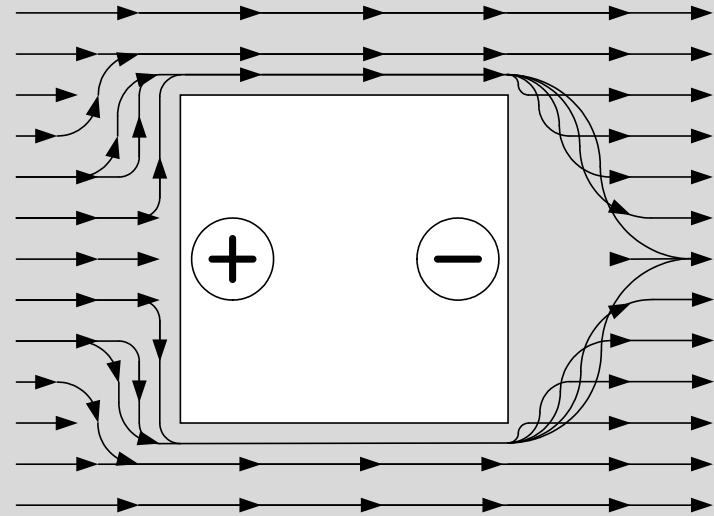

Negative Design Pressures

When an opening is breached, *internal pressure* is effectively doubled!



SIDE
VIEW

WIND PRESSURE ON ROOF.
INTERNAL PRESSURE ADDS TO ROOF UPLIFT.

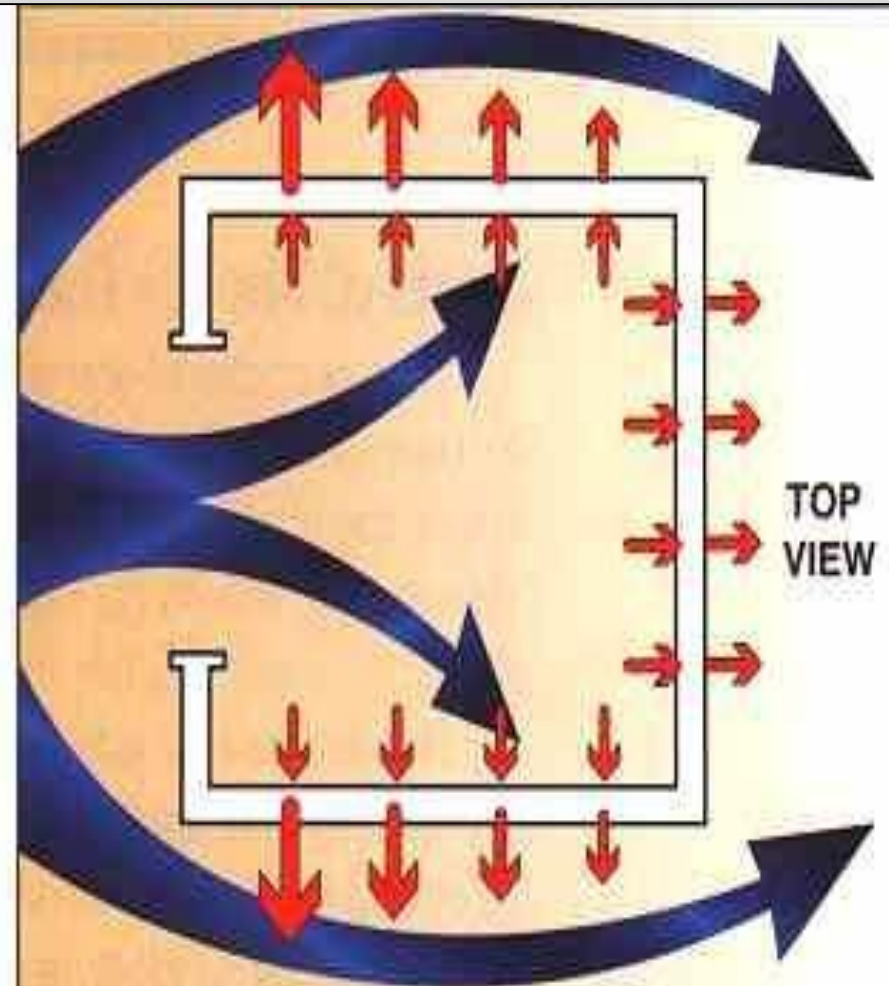

TOP
VIEW

WIND PRESSURE ON WALLS.
INTERNAL PRESSURE ADDS TO WALL SUCTION.

Interior and End Zones

5th Edition (2014) Florida Building Code: Residential

Walls

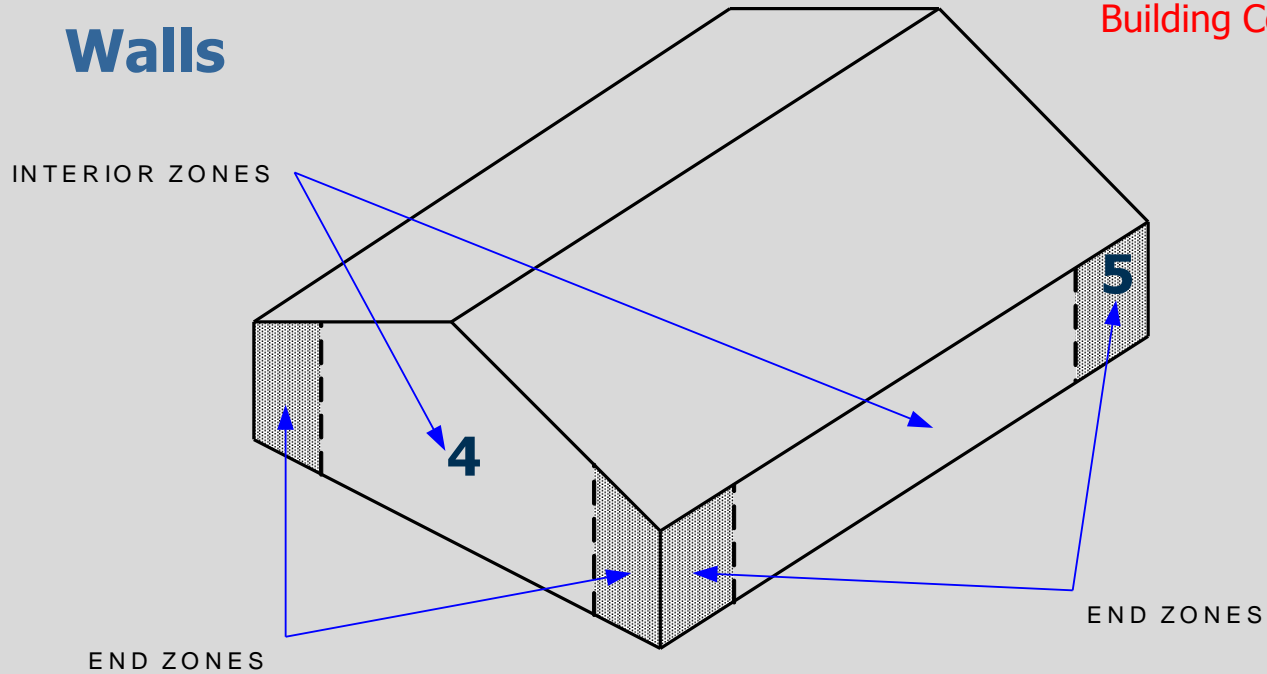

Gable Roofs $10^\circ < \theta \leq 45^\circ$

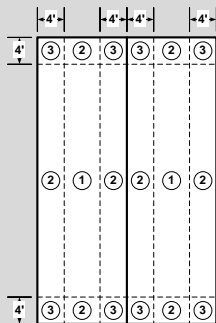

Gable Roofs $\leq 10^\circ$

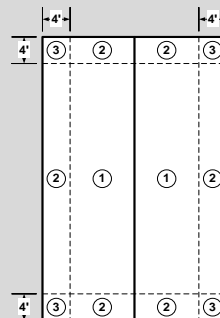

Hip Roofs $10^\circ < \theta \leq 30^\circ$

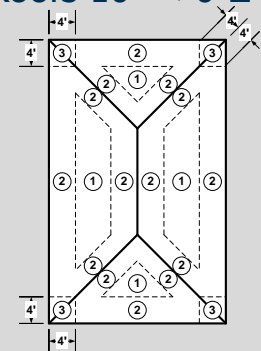

Testing & Label Requirements

Testing

Section 1710.5.1 Testing and Labeling. Exterior windows and glass doors shall be tested by an **approved independent testing laboratory**, and shall be **labeled** to indicate compliance with the requirements of one of the following specifications:

ANSI/AAMA/NWWDA 101/I.S. 2 or
ANSI/AAMA/WDMA/101/I.S.2/NAFS or AAMA/WDMA/CSA
101/I.S.2/A440 or TAS 202
(HVHZ shall comply with TAS 202 utilizing ASTM E
1300 or Section 2404).

AAMA 101-97 (FL Product Approval)

Non-Impact Test

Testing Order

- Air Infiltration
- Water Infiltration
- Full Structural Load (10 seconds)
- Forced Entry

TAS 202 (Miami-Dade NOA)

Non-Impact Test

Testing Order

- Air Infiltration
- 1/2 Structural Load +/- (30 seconds)
- Water Infiltration
- Full Structural Load (30 seconds)
- Forced Entry

ASTM E 1996

Impact Test Requirements

Level of Protection	Enhanced Protection (Essential Facilities)		Basic Protection		Unprotected	
	≤ 30 ft	> 30 ft	≤ 30 ft	> 30 ft	≤ 30 ft	> 30 ft
Wind Zone I	C	C	B	A	None	None
Wind Zone II	C	C	B	A	None	None
Wind Zone III	D	D	C	A	None	None
Wind Zone IV	E	D	D	A	None	None

- Missile Level A (Small Missile)
Ten 2 gram steel balls shot at 130 feet/second
- Missile Level B
2 lb (1'9") 2x4 shot at 50 feet/second
- Missile Level C
4.5 lb (4'4") 2x4 shot at 40 feet/second
- Missile Level D
9 lb (8'4") 2x4 shot at 50 feet/second
- Missile Level E
9 lb (8'4") 2x4 shot at 80 feet/second

ASTM E 1996 (FL Product Approval)

Impact Test

R301.2.1.2 and R301.2.1.2.1

Large Missile

- 4.5 lb. 2x4 @40 fps
- Test 3 specimens
- No structural shot (140 mph & below)
- Air Pressure Cycling
 - 4500 Positive, 4500 Negative cycles
- No tear greater than 5" or an opening up to 3" in diameter
- Not acceptable in HVHZ

TAS 201 & 203 (Miami-Dade NOA)

Impact Test

Large Missile

- 9 lb. 2x4 @ 50 fps.
- 3 specimens
- 2 impacts each
- Two specimens are required to take a structural shot
- Air Pressure Cycling
 - 4500 Positive, 4500 Negative cycles
- No tear over 1/16" x 5"
- Accepted statewide

Test Comparisons

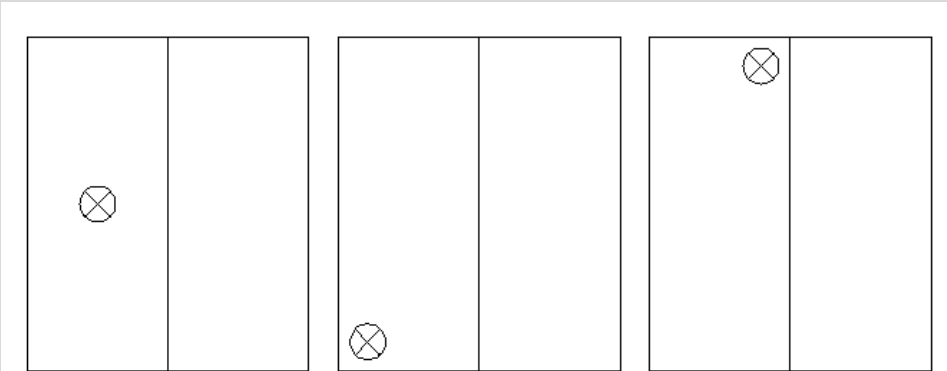

Figure 1. ASTM E1886/1996 Large Missile Impacts

ASTM Testing

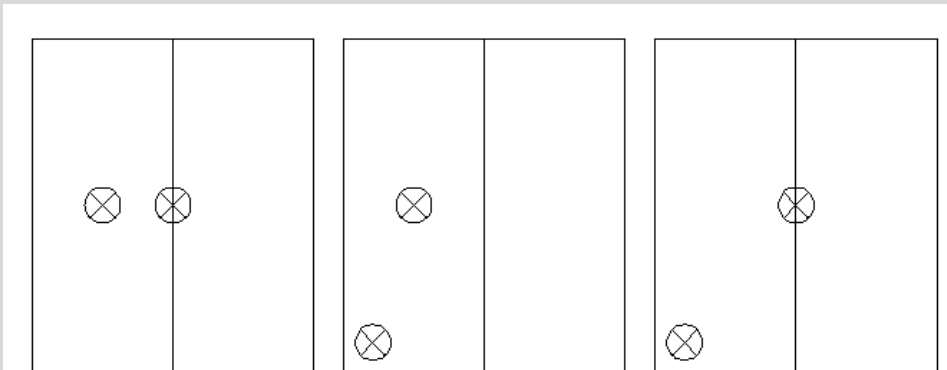

Figure 2. TAS 201/203 Large Missile Impacts

TAS Testing

Cyclic Wind Loads

Cyclic Wind Load Test

- Product is cycled to engineered maximum design pressure
- Completed on impact resistant products only

Florida Product Approval

Florida state law, Rule 61G20-3 specifies that all parts of the building envelope must have third-party QA through a state-approved entity

QA must be documented in either:

- Florida Product Approval (statewide)
- Local Product Approval (county by county)

Building Officials must accept Florida Product Approvals.

- Additional info may be required at officials discretion

Labeling

Section 1710.5.1 Exterior windows and doors.

Exterior windows and doors shall be tested by an approved independent testing laboratory, and shall be labeled to indicate compliance with the requirements of one of the following specifications:

ANSI/AAMA/NWWDA 101/I.S. 2 or 101/I.S.2 NAFS or AAMA/WDMA/CSA 101/I.S.2/A440 or TAS 202 (HVHZ shall comply with TAS 202 utilizing ASTM E 1300 or Section 2404).

Labeling

Section R612.3 Testing and Labeling. Exterior windows and doors shall be tested by an approved independent testing laboratory, and shall be labeled with an approved permanent label identifying the manufacturer, the product model/series number, performance characteristics and approved product certification agency, testing laboratory, evaluation entity or Miami-Dade Product Approval to indicate compliance with the requirements of one of the following specifications:

ANSI/AAMA/NWWDA 101/I.S.2 or 101/I.S.2 NAFS or AAMA/WDMA/CSA 101/I.S.2/A440 or TAS 202 (HVHZ shall comply with TAS 202 utilizing ASTM E 1300-98 or ASTM 1300-04 02).

ASTM E1300-98/04 Glass Table

- Ages new glass 20 years
- Reduces glass strength
- 12 Tables specific to glass thickness
- The Florida Building Code requires editions of ASTM E1300-04e01, E1300-07e01, or E1300-09a to be used. (E1300-98 in HVHZ)

Required Testing Label

Example of a self label with Miami-Dade NOA

Test entity

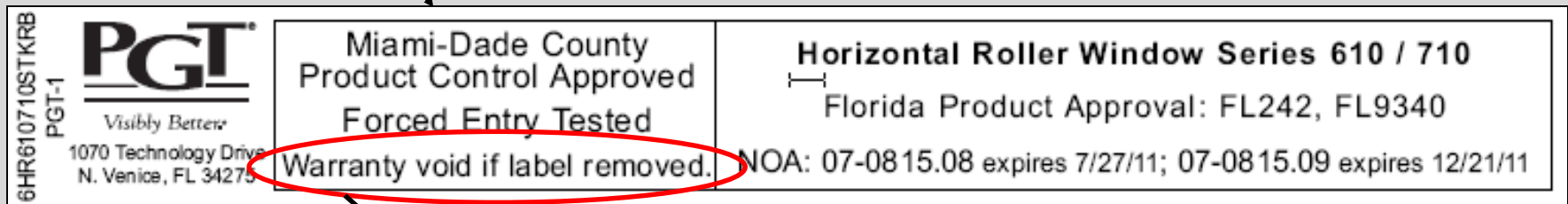

Warranty void if label removed.

Manufacturers Glass Identification

Section 2403.1 Identification.

Each pane shall bear the manufacturer's mark designating the type and thickness of the glass or glazing material. With the exception of tempered glazing materials or laminated materials, the identification shall not be omitted unless *approved* and an affidavit is furnished by the glazing contractor certifying that each light is glazed in accordance with *approved construction documents* that comply with the provisions of this chapter. Safety glazing shall be identified in accordance with Section 2406.3.

Each pane of tempered glass shall be permanently identified by the manufacturer and each pane of laminated glass shall be permanently identified with the laminator, overall glass thickness and trade name of interlayer. The identification *mark* shall be acid etched, ceramic fired, laser etched, embossed, sand etching or of a type that, once applied, cannot be removed without being destroyed. Tempered or laminated spandrel glass shall be provided with a removable paper marking by the manufacturer.

"M"iami
"D"ade
"C"ounty
"A"pproved"

Laminator
Logo



"L"aminated
"S"afety
"G"lass"

Required by
Code for all
Safety
Glazing

ANSI Standard
for plastic
materials used in
safety glazing

Overall Laminated
Glass Thickness

"S"afety
"G"lazing
"C"ouncil
"C"ertification
Number

ENERGY STAR[®] Qualified in Highlighted Regions





DESIGN PRESSURE

+64.0 - 80.0 PSF

Design Pressures Limited by tested pressures, ASTM E1300 Glass Tables, and anchorage. Positive Design Pressure also limited by water test pressure.

Glazing: 13/16" LIG (1/8 HS -1/4 AIR -7/16 ANN/ANNLAMI)

FL239, IMPACT RESISTANT
 PA/TAS 201,202,203, LOW SILL
 FIN OR FLANGE
 177283-00-001 SH700
 02/13/09 13:51:30 35.500X 721F B/LEH HLCIG VIEW VW B 1

 National Fenestration Rating Council® CERTIFIED	 <i>Visibly Better.</i>
	WINGUARD SH SERIES 700 SERIES ALUMINUM FRAME DUAL GLAZED * AIR FILL * LOW E*W/ GRIDS Product Type: SINGLE HUNG

ENERGY PERFORMANCE RATINGS	
U Factor(U.S.) 0.67	Solar Heat Gain Coefficient 0.30
ADDITIONAL PERFORMANCE RATINGS	
Visible Transmittance 0.51	_____

Manufacturer stipulates that these ratings conform to applicable NFRC procedures for determining whole product performance. NFRC ratings are determined for a fixed set of environmental conditions and a specific product size. NFRC does not recommend any product and does not warrant the suitability of any product for any specific use. Consult manufacturers literature for other product performance information. www.nfrc.org

DO NOT REMOVE LABEL PRIOR TO INSPECTION

Florida Building Code, 5th Edition (2014): Building

Wind-Borne Debris Protection

- Protection of openings
- Wind-Borne Debris Regions
- Options

Building Code

Section 1609.1.2 Protection of openings.

In *wind-borne debris regions*, glazed openings in buildings shall be impact resistant or protected with an impact-resistant covering meeting the requirements of SSTD 12, ANSI/DASMA 115 (for garage doors and rolling doors) or TAS 201, 202 and 203, AAMA 506. ASTM E 1996 and ASTM E 1886, referenced herein, or an *approved* impact-resistant standard as follows:

- 1.** Glazed openings located within 30 feet (9144mm) of grade shall meet the requirements of the large missile test of ASTM E 1996
- 2.** Glazed opening located more than 30 feet (9144mm) above grade shall meet the provisions of the small missile test of ASTM E 1996

Exceptions:

- 3.** Glazing in Occupancy Category II, III or IV buildings located over 60 feet above the ground and over 30 feet above aggregate surface roofs located within 1,500 feet of the building shall be permitted to be unprotected.

Opening Protection

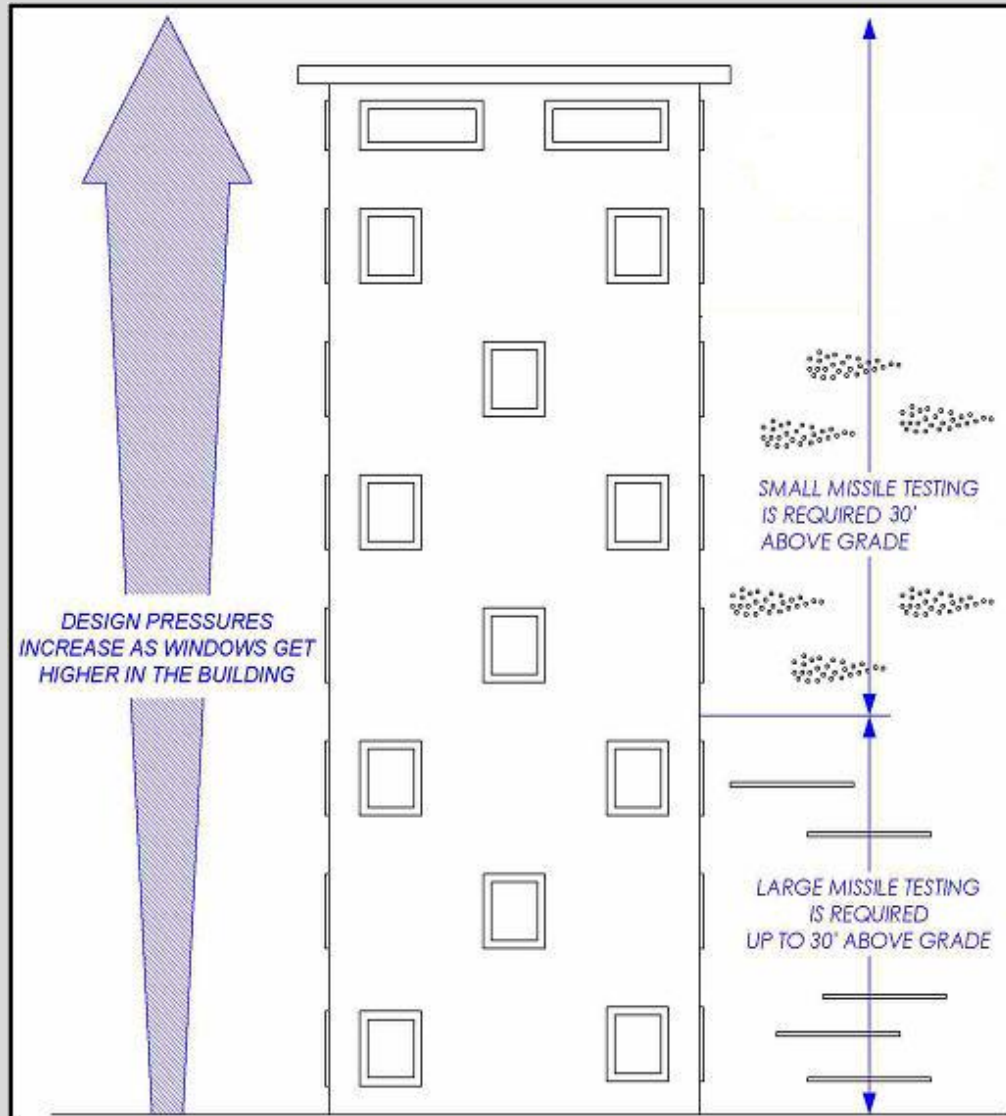

Florida Building Code, 5th Edition (2014): Building

Residential Code

Section R301.2.1.2 Protection of openings.

Glazed openings in buildings located in windborne debris regions shall be protected from windborne debris.

Glazed opening protection for windborne debris shall meet the requirements of the Large Missile Test of ASTM E1996 and ASTM E1886 referenced therein, SSTD 12, TAS 201, 202 and 203 or AAMA 506, as applicable.

Category II Wind Speed Map

Risk Category II ...
defined as “All buildings and other structures except those listed in Risk Categories I, III, and IV” and includes residential and most commercial and industrial structures

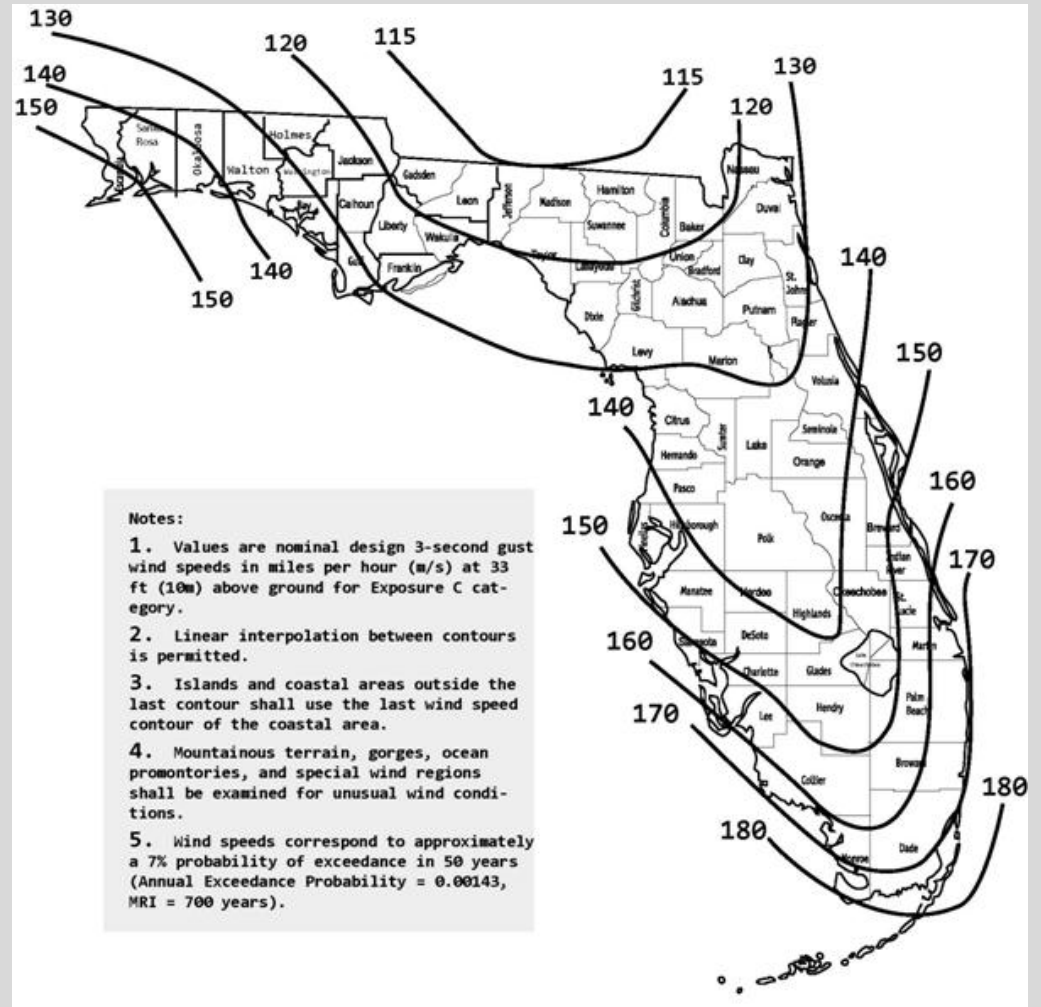

FIGURE 1609A

ULTIMATE DESIGN WIND SPEEDS, V_{ult} FOR RISK CATEGORY II
BUILDINGS AND OTHER STRUCTURES

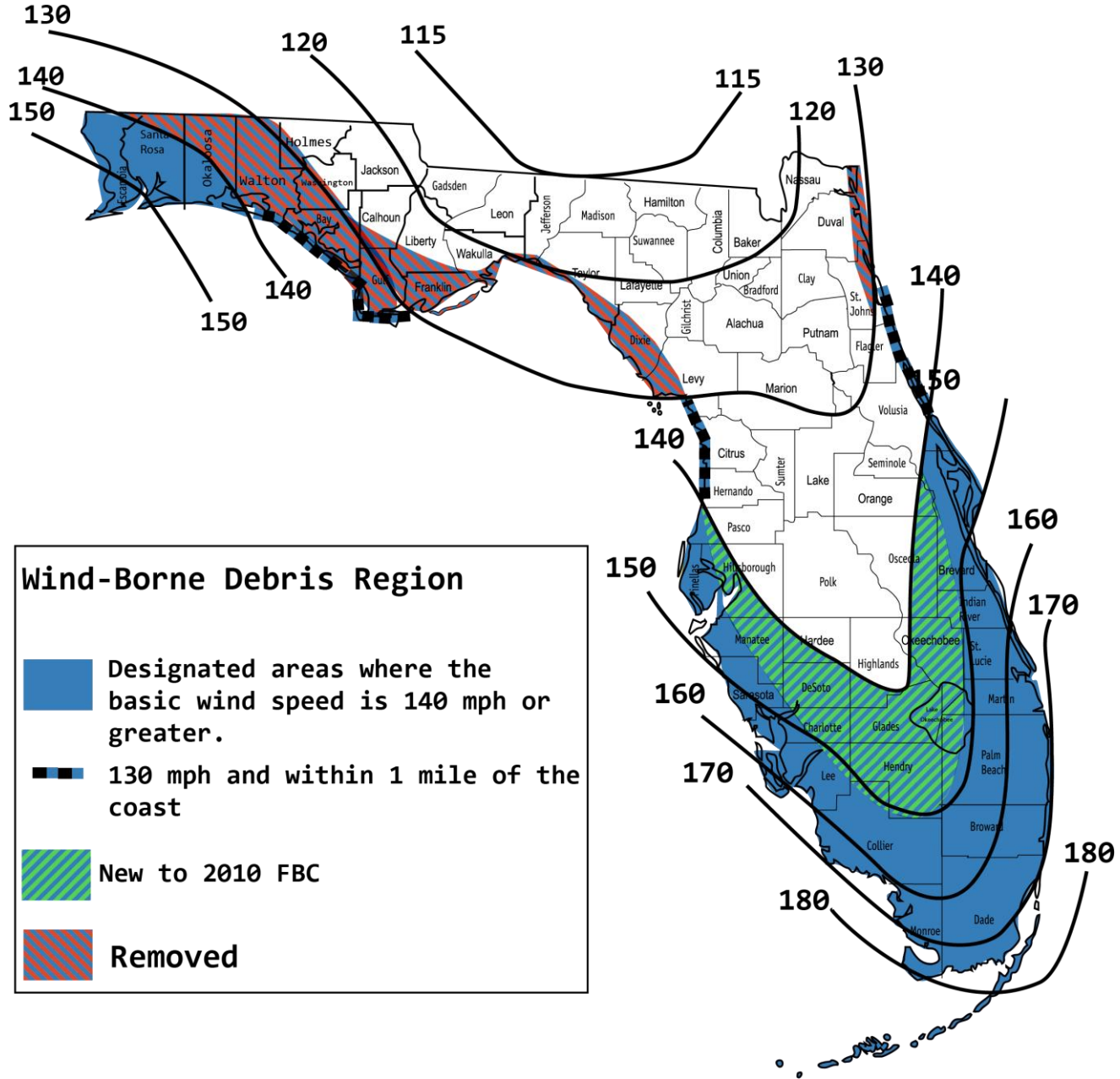

Figure 1609A Wind-Borne Debris Region, Category II and III Buildings and Structures except health care facilities

Impact Resistant Coverings

R615.2 Labels: A permanent label shall be provided by the product approval holder on all impact-resistant coverings.

R615.2.1 The following information shall be included on the labels on impact-resistant coverings:

- Product approval holder name and address.
- All applicable methods of approval. Methods of approval include, but are not limited to Miami-Dade, Notice of Acceptance (NOA); Florida Building Commission, TDI Product Evaluation; ICC-ES.
- The test standard or standards specified at Section R301.2.1.2
- For products with a Florida Product Approval Number or Miami-Dade County Building and Neighborhood Compliance Department NOA Number, such numbers shall be included on the label

Wood Structural Panels

7/16" wood panels with anchorage systems in place

- Upside
 - Inexpensive
 - Installed by a homeowner
- Downside
 - Difficult to install and un-install





Panel Shutters

- Upside
 - Material options available
 - Not permanently attached
- Downside
 - Difficult to install and un-install
 - Requires storage space



R615.3 Label: Embossed or printed facing the exterior or outside not more than every 3 lineal feet on each panel



Florida Building Code, 5th
Edition (2014): Residential

Accordion Shutters

- Upside
 - Significantly less labor
 - No storage needed
- Downside
 - More expensive than panel shutters
 - Aesthetically obtrusive



R615.3 Label: Bottom of the locking bar or center mate facing the exterior or outside



Roll Up Shutters

- Upside
 - Significantly less labor
 - No storage needed
- Downside
 - More expensive than panel and accordion shutters
 - Aesthetically obtrusive



R615.3 Label: Bottom of the hood or slat facing the exterior or outside



Impact-Resistant Windows and Doors

- Upside
 - Aesthetically pleasing
 - Security 24 / 7
- Downside
 - More expensive than standard aluminum windows
 - If impacted hard enough the glass will break



R615.3 Label: Shall be on the side or bottom facing the exterior or outside



Peace of Mind ... When Away



24 / 7 Protection



Glass Replacement

Section 2401.2 Glazing replacement.

The installation of replacement glass shall be as required for new installations.



Window Films

- Developed in Israel for bomb blast protection, then in the U.S. designed for energy efficiency purposes in the 1960's
- Voids most manufacturers warranty
- Generally, field applied films DO NOT meet Dade County large missile impact requirements
- Product testing completed, however no product certifications received
- Some have been tested to obsolete small missile requirements

Florida House Bill 849

“A product may not be advertised, sold, offered, provided, distributed, or marketed as hurricane, wind storm, or impact protection from wind-borne debris during a hurricane or wind storm unless it is approved pursuant to s. 553.842 or s. 553.8425. Any person who advertises, sells, offers, provides, distributes, or markets a product as hurricane, windstorm, or impact protection from windborne debris without such approval is subject to the Florida Deceptive and Unfair Trade Practices Act under part II of chapter 501 brought by the enforcing authority as defined in s.501.203.”

Effective Date July 1, 2011

Impact Resistant Coverings

Section R615.4 Installation

All impact-resistant coverings shall be installed in accordance with the manufacturer's installation instructions and in accordance with the product approval. Installation instructions shall be provided and shall be available to inspection personnel on the job site. Opening protection components, fasteners, and other parts evaluated by an approved product evaluation entity, certification agency, testing laboratory, **architect**, or engineer and approved by the holder of the product approval may be interchangeable in opening protection assemblies provided that the opening protection component(s) provide equal or greater structural performance and durability as demonstrated by testing in accordance with approved test standards.

Are You Specifying ...



V
S



And Allowing ...



V
S

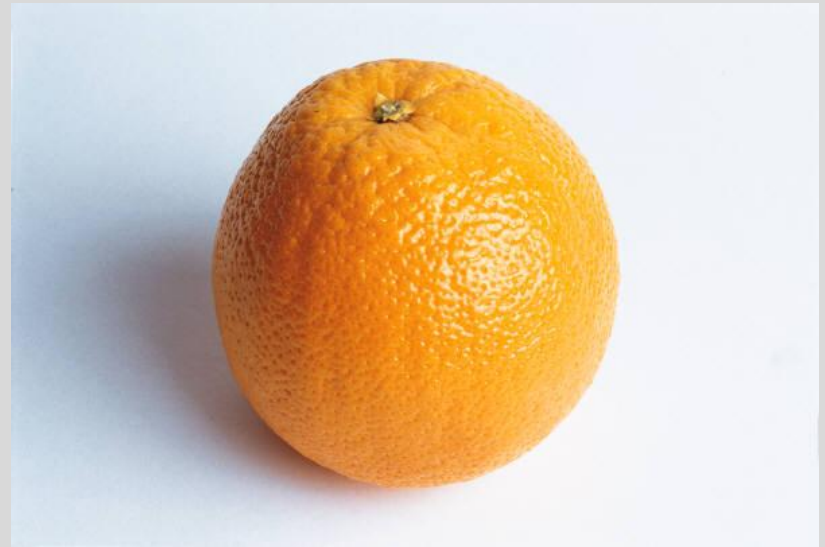

Installation Instructions

Section R703.8 Flashing ...

Flashing at exterior window and door openings shall be installed in accordance with one or more of the following:

- 1.1 The fenestration manufacturer's installation and flashing instructions or the flashing manufacturer's written flashing instructions
- 1.2 In accordance with the flashing design or method of a registered design professional
- 1.3 In accordance with other approved methods
- 1.4 In accordance with FMA/AAMA 100, FMA/AAMA 200, FMA/WDMA 250, FMA/AAMA/WDMA 300

Flashing Best Practice Instructions

- **FMA/AAMA 100-12** ... standard practice for installation of windows with flanges or mounting fins in wood frame construction
- **FMA/AAMA 200-12** ... standard practice for installation of windows with frontal flanges for surface barrier masonry construction for extreme wind/water conditions
- **FMA/WDMA 250-12** ... standard practice for installation of non-frontal flange windows with mounting flanges for surface barrier masonry construction for extreme wind/water conditions
- **FMA/AAMA/WDMA 300-12** ... standard practice for installation of exterior doors in wood frame construction
- **FMA/AAMA/WDMA 400-13** ... standard practice for installation of exterior doors in surface barrier masonry Construction for extreme wind/water exposure

Flashing and Sealants

Section R703.8 Flashing.

Approved corrosion-resistant flashing shall be applied shingle-fashion in a manner to prevent entry of water into the wall cavity or penetration of water to the building structural framing components. Self-adhered membranes used as flashing shall comply with AAMA 711. All exterior fenestration products shall be sealed at the juncture with the building wall with a sealant complying with **AAMA 800 or ASTM C 920** Class 25 Grade NS or greater for proper joint expansion and contraction, ASTM C 1281, AAMA 812, or other approved standard as appropriate for the type of sealant.

General Window Installation Instructions

Section R312.2.1 Window sills.

In dwelling units, where the opening of an operable window is located more than 72 inches (1829 mm) above the finished grade or surface below, the lowest part of the **clear opening** of the window shall be a minimum of 24 inches (610 mm) above the finished floor of the room in which the window is located. Operable sections of windows shall not permit openings that allow passage of a 4 inch-diameter (102mm) sphere where such openings are located within **24 inches** (610mm) of the finished floor.

Hazardous Locations for Glazing

Change Summary ...

The provisions for hazardous locations related to the installation of glazing have been reorganized for ease of use and consistent application. Each item in the numbered list of hazardous locations has been placed in a separate subsection and given a descriptive title.

Hazardous Locations for Glazing

R308.4 Hazardous Locations.

- R308.4.1 Glazing in Doors
- R308.4.2 Glazing Adjacent Doors
- R308.4.3 Glazing in Windows
- R308.4.4 Glazing in Guards & Railings
- R308.4.5 Glazing and Wet Surfaces
- R308.4.6 Glazing Adjacent to Stairs & Ramps
- R308.4.7 Glazing Adjacent to the bottom Stair Landing

Emergency Escape & Rescue

Section 1029.2 Minimum size

Emergency escape and rescue openings shall have a minimum net clear opening of 5.7 square feet (0.53 m²).

Exception: The minimum net clear opening for grade-floor *emergency escape and rescue openings* shall be 5 square feet (0.46 m²).

Emergency Escape & Rescue

Section 1029.2.1 Minimum dimensions

The minimum net clear opening height dimension shall be 24 inches (610 mm). The minimum net clear opening width dimension shall be 20 inches (508 mm). The net clear opening dimensions shall be the result of normal operation of the opening.

Means of Egress / Repairs

R310.1 Emergency Escape and Rescue Required.

Where emergency escape and rescue openings are provided, they shall have a sill height of not more than 44 inches measured from the finished floor to the bottom of the clear opening.

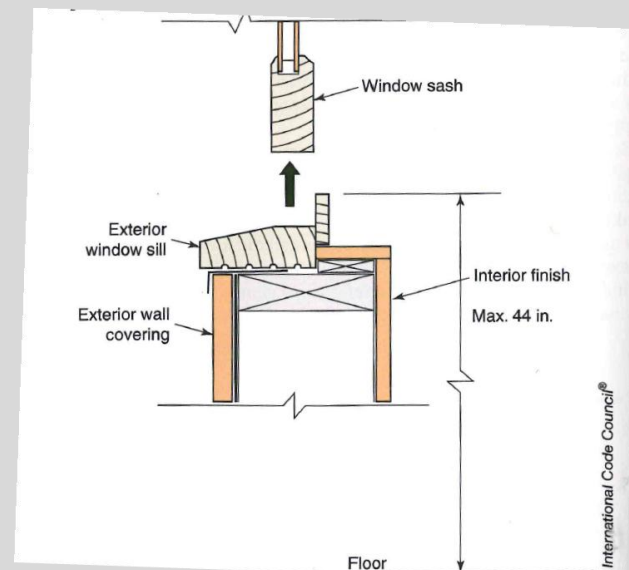

Florida Building Code, 5th Edition
(2014): Residential

Emergency Escape & Rescue

Section 1029.3 Maximum Height from floor

Emergency escape and rescue openings shall have the bottom of the *clear opening* not greater than 44 inches (1118 mm) measured from the floor

Definition of "Bedroom"

BEDROOM. A room that can be used for sleeping and that:

For site-built dwellings has a minimum of 70 square feet of conditioned space;

For manufactured homes is constructed according to the standards of the United States Department of Housing and Urban Development and has a minimum of 50 square feet of floor area;

Is located along an exterior wall;

Has a closet and a door or an entrance where a door could be reasonable installed;

Has an emergency means of escape and rescue opening to the outside in accordance with the *Florida Building Code*.

Threshold Height

Section 1008.1.7

Thresholds at doorways shall not exceed 3/4 inch (19.1 mm) in height for sliding doors serving dwelling units or 1/2 inch (12.7 mm) for other doors. Raised thresholds and floor level changes greater than 1/4 inch (6.4mm) at doorways shall be beveled with a slope not greater than 1 unit vertical in two units horizontal (50-percent slope).

Exceptions:

2. For exterior doors serving dwelling units, **thresholds at doorways shall not exceed the height required to pass the water resistance test** of ANSI/AAMA/WDMA 101/I.S.2, or TAS 202 for high-velocity hurricane zones, or the maximum allowable height difference between interior floor level.

Exception

706.4

1. Opening Protection Exception: For one-and two-family dwellings constructed under codes other than the *Florida Building Code* and located in wind-borne debris regions, the replacement of garage doors and exterior doors with glazing, sliding glass doors, glass patio doors, skylights, and operable and inoperable windows within any 12 month period shall not be required to have opening protection, but shall be designed for wind pressures for enclosed buildings provided the aggregate area of the glazing in the replaced components does not **exceed 25% of the aggregate area of the glazed openings in the dwelling or dwelling unit.**

2. Opening Protection Exception for High Velocity Hurricane Zone: For one-and two-family dwellings constructed under codes prior to September 1, 1994 the replacement of exterior doors with glazing...

Water Limitations

Water Limitations from Referenced Standards

- Affects only the positive pressure
- Water limitation is done at the test lab
- Water pressure is typically 15% of the design pressure

Example:

$$\text{DP } 60 \times .15 = 9 \text{ psf water}$$

Water Limitation Exceptions

Section 1710.5.1 Exterior Windows and doors.

Exceptions:

2. Door assemblies installed where the *overhang (OH) ratio is equal to or more than 1* need not be tested for water infiltration. The overhang ratio shall be calculated by the following equation:

$$\text{OH ratio} = \text{OH Length} / \text{OH Height}$$

OH Length = The horizontal measure of how far an overhang over a door projects out from door surface.

OH Height = The vertical measure of the distance from the door sill to the bottom of the overhang over a door.

Florida Building Code, 5th
Edition (2014): Building

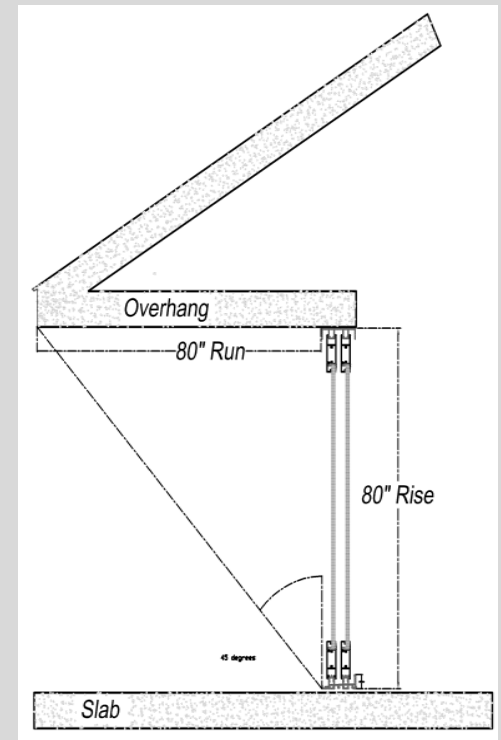

Exterior Windows & Doors

Section 1710.5.1 Exterior Windows & Doors.

Exceptions:

5. Pass-through windows for serving from a single-family kitchen, where protected by a roof overhang of **5 feet** (1.5 m) or more shall be exempted from the requirements of the water infiltration test.

Lead Renovation, Repair and Painting (RRP)

The Lead-Based Paint Renovation, Repair and Painting program is a federal regulatory program affecting contractors, property manager and other who disturb painted surfaces.

- Applies to residential houses, apartments, and child-occupied facilities such as schools, day-care centers build before 1978.
- Includes pre-renovations education requirements as well as training, certification and work practice requirements.
- Effective date: April 22, 2010
 - Firms must be certified
 - Renovators must be trained and certified

Florida Product Approval Compliance

www.floridabuilding.org

Find product or application under 2010 dropdown

Ensure that application detail Code Version is **Version 5 (2014)**

Products not shown under this version are **not** in compliance

The screenshot shows a web browser window with the URL http://floridabuilding.org/pr/pr_app_dtl.aspx?param=wGEVXQ. The page title is "Florida Building Code Online". The browser's search bar contains "2010" and shows "2 matches".

The website header includes the text "FLORIDA DEPARTMENT OF Business & Professional Regulation". A navigation menu contains links for "BCIS Home", "Log In", "User Registration", "Hot Topics", "Submit Surcharge", "Stats & Facts", "Publications", "FBC Staff", and "BCIS Site Ma".

The main content area features the "Product Approval" logo and the text "USER: Public User". A breadcrumb trail reads: "Product Approval Menu > Product or Application Search > Application List > Application Detail".

On the left side, there is a green sidebar with the text "EMERGENCY MANAGEMENT" and "OFFICE OF THE SECRETARY".

The application details are as follows:

FL #	FL239-R17
Application Type	Revision
Code Version	2010
Application Status	Approved
	*Approved by DCA. Approvals t Commission if necessary.
Comments	
Archived	<input type="checkbox"/>

Miami Dade NOA Compliance

NOA Number Example:

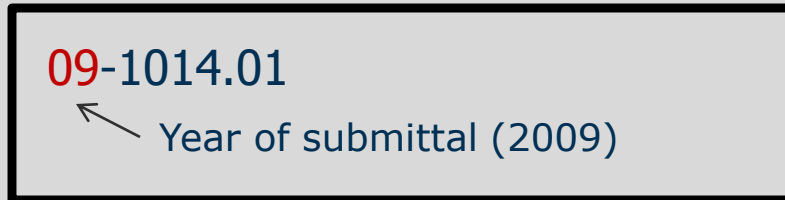

If the fenestration NOA begins with 10- or earlier product is **not** in compliance the FBC Version 5 (2014) building code

If NOA begins with 11- or 12- proceed to check the NOA Evidence Submitted Page (typically page 2 of NOA) to ensure that compliance is stated to FBC Version 5 (2014)

NOTICE OF ACCEPTANCE: EVIDENCE SUBMITTED

C. CALCULATIONS

1. Statement letter dated OCT 11, 2011 of compliance to FBC 2007 & FBC 2010,

The 2010 Confusing Issues!

Table 101.4.1 NONEXEMPT EXISTING BUILDINGS

Exception “d” reads ...

“Buildings undergoing alteration that vary or change insulation, HVAC systems, water heating systems, or exterior envelope provided that the estimated cost exceeds 30 percent of the assessed value of the structure”

R402.3.6 Replacement fenestration. Where some or all of an existing fenestration unit is replaced with a new fenestration product, including sash and glazing, the replacement fenestration unit shall meet the applicable requirements for *U*-factor and SHGC in Table 402.1.1.

Replacement Fenestration

R101.4.7 Building Systems and Components.

Thermal efficiency standards are set for the following building systems and **components** where new products are installed or replaced in existing buildings, and for which a permit must be obtained. New products shall meet the minimum efficiencies allowed by this code for the following systems and **components**:

Heating, ventilating or air conditioning systems.

Service water or pool heating systems.

Lighting systems.

Replacement Fenestration.



Let's eat Grandma!

Let's eat, Grandma!

Punctuation saves lives.

Florida Energy Climate Zones

Florida will be broken into two specific Climate Zones.

Both with different code requirements and product needs.

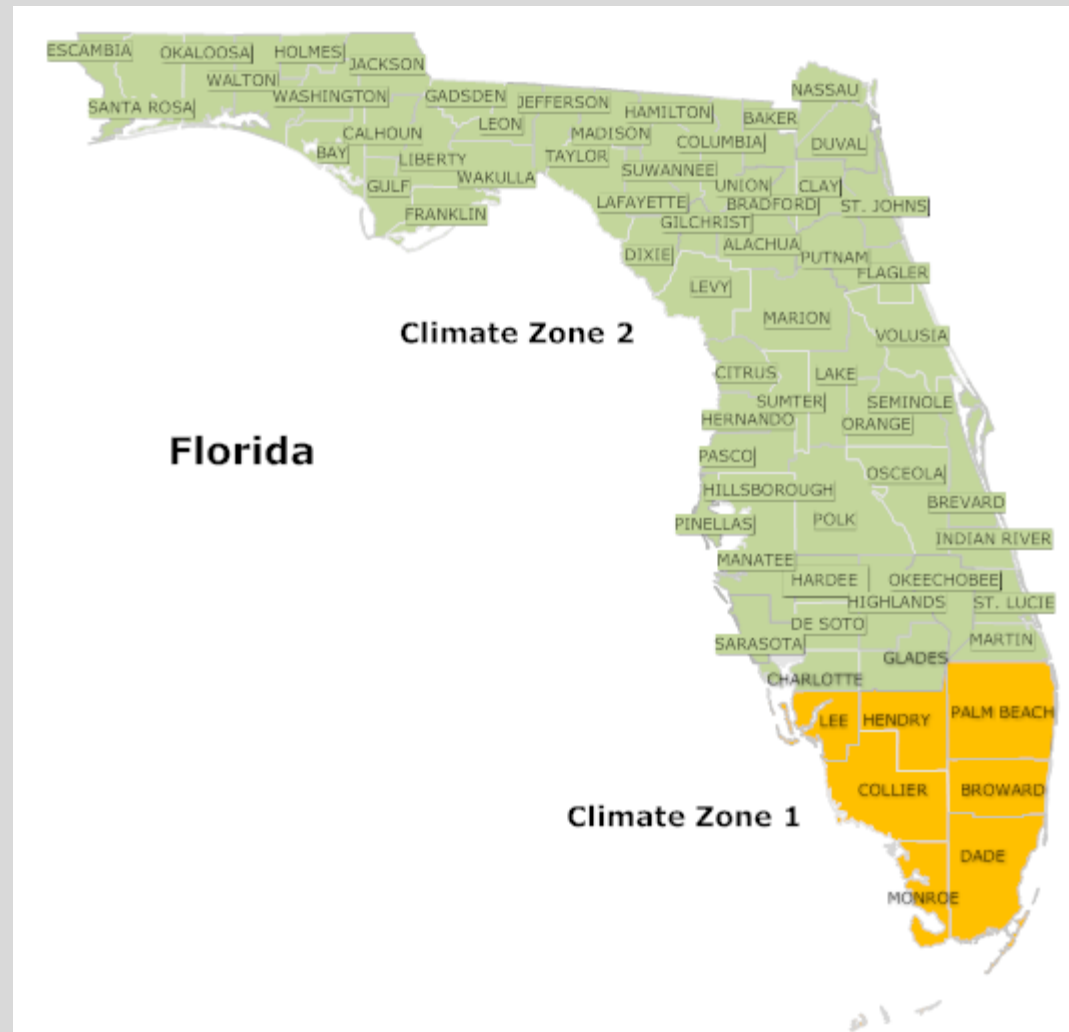

Florida *Residential* Requirements

Prescriptive Path

Zone 1 (Dade, Broward, Monroe, Palm Beach, Collier, Lee, Hendry Counties)

Non-Impact windows

U .65 SHGC .25

Impact windows

U .75 SHGC .25

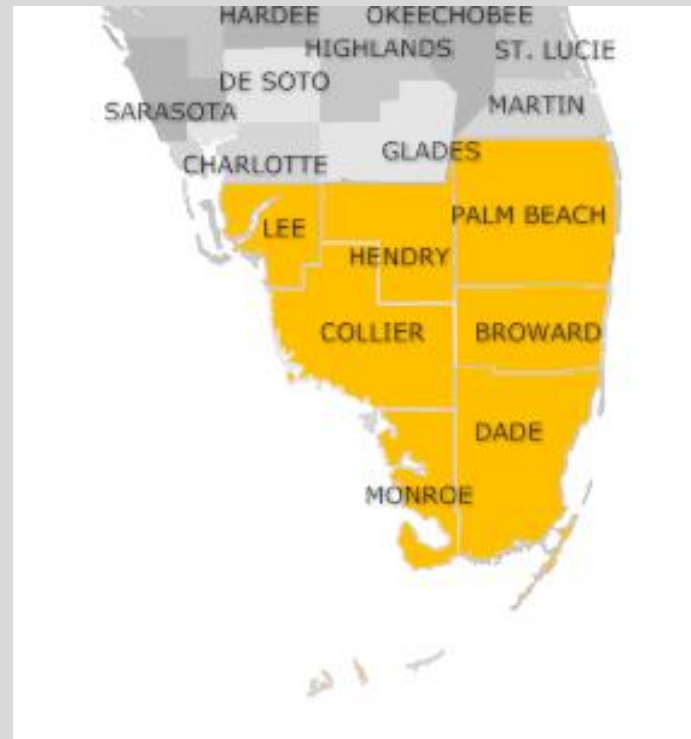

Florida *Residential* Requirements

What does this mean? ...

Zone 1 (Dade, Broward, Monroe, Palm Beach, Collier, Lee, Hendry Counties)

Non-Impact windows U .65 SHGC .25

- Aluminum will still be available but will be Insulated High Performance LowE. No option for Monolithic glass in non-impact windows,
- Vinyl will be more widely introduced into the market to meet codes.

Impact windows U .75 SHGC .25

- Aluminum will still be available but most manufacturers will have to use Insulated Impact – High Performance LowE.
- Vinyl will be more widely introduced into the market. Limitation will be structural DP Ratings.

Florida *Residential* Requirements

Climate Zone 2 – All Florida except Climate Zone 1.

Non-Impact windows

U .40 SHGC .25

Impact windows

U .65 SHGC .25

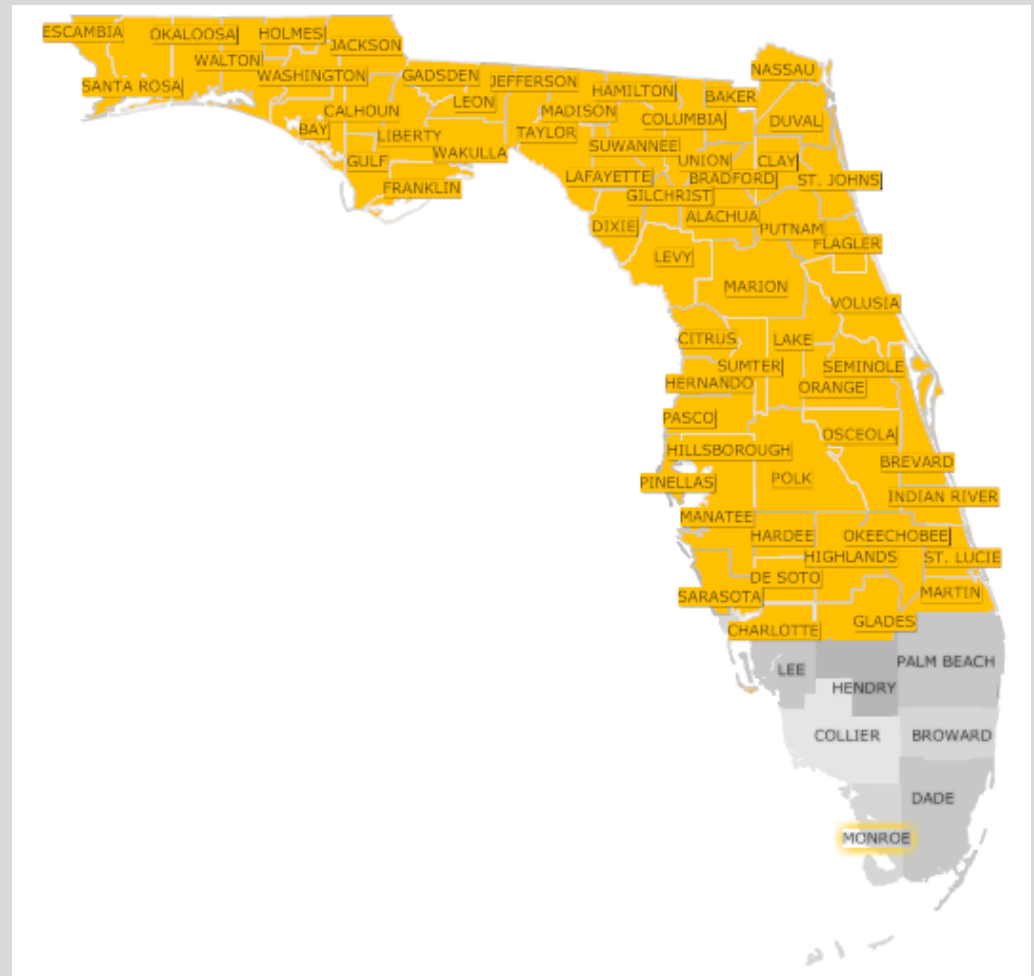

Florida *Residential* Requirements

What does this mean? ...

Zone 2 (All of Florida outside of Zone 1)

Non-Impact windows U .40 SHGC .25

- Aluminum will for the most part no longer be able to be used outside Zone 1 for replacement applications.
- Zone 2 will become a vinyl market.

Impact windows U .65 SHGC .25

- Aluminum may still be available, but some current products cannot meet the .65 U value. .25 SHGC can be achieved with High Performance IG Glass.
- Most jobs will require vinyl impact, which will have High Performance IG Glass.

Florida *Commercial* Requirements

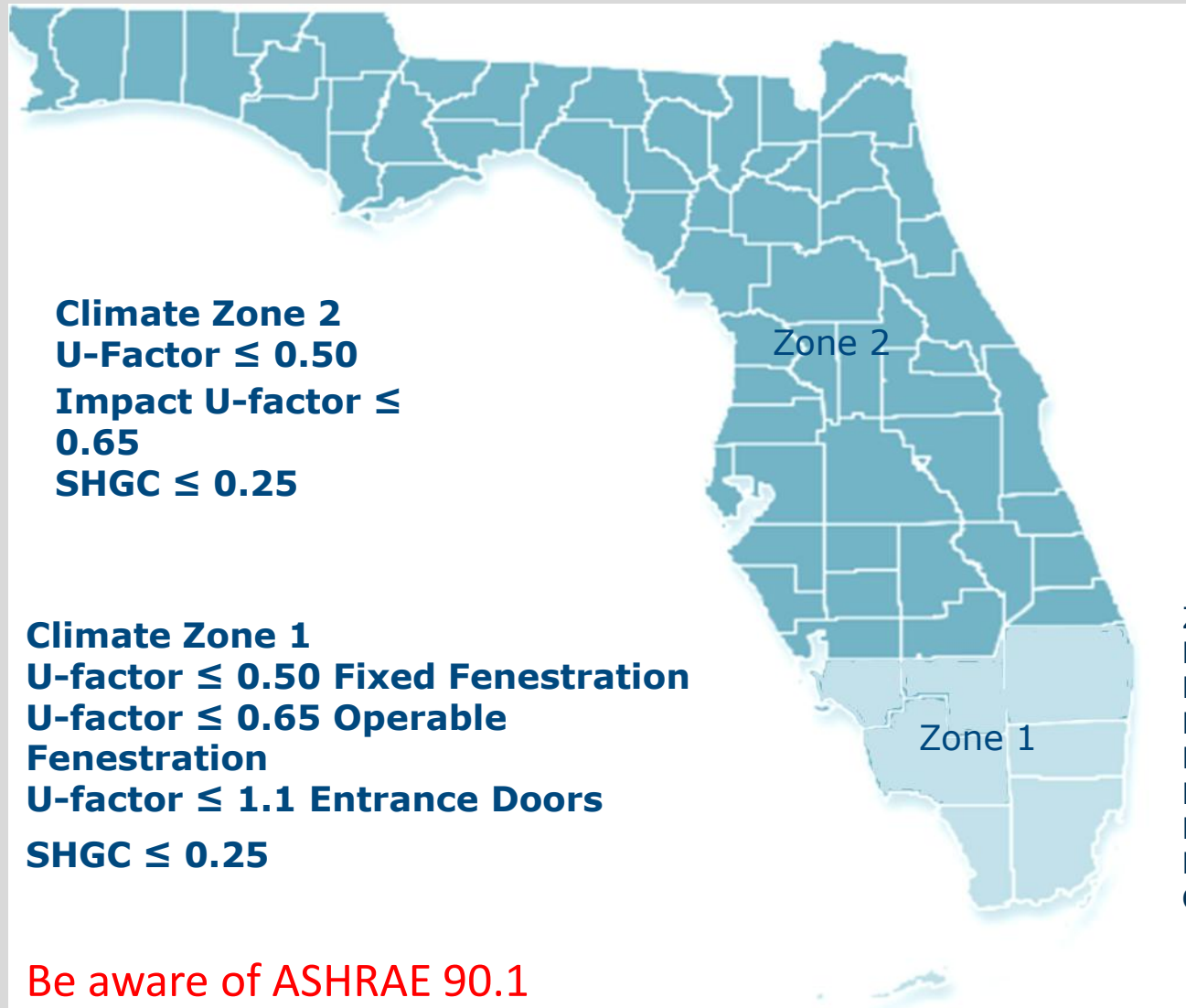

Florida *Commercial* Requirements

SECTION C401 GENERAL

C401.1 Scope.

The requirements contained in this chapter are applicable to commercial buildings, or portions of commercial buildings.

C401.2 Application.

Commercial buildings shall comply with **one** of the following:

1. **The requirements of ANSI/ASHRAE/IESNA 90.1.**
2. The requirements of Sections C402, C403, C404 and C405. In addition, commercial buildings shall comply with either Section C406.2, C406.3 or C406.4.
3. The requirements of Section C407, C402.4, C403.2, C404, C405.2, C405.3, C405.4, C405.6 and C405.7. The building energy cost shall be equal to or less than 85 percent of the standard reference design building.

C401.2.1 Application to existing buildings.

Additions, alterations and repairs to existing buildings shall comply with **one** of the following:

1. Sections C402, C403, C404 and C405; or
2. **ANSI/ASHRAE/IESNA 90.1.**

ASHRAE 90.1

ASHRAE 90.1-2010 Prescriptive Fenestration Requirements								
Climate Zone	1	2	3	4	5	6	7	8
Vertical Fenestration								
Maximum U-factor								
Framing materials other than metal with or without metal reinforcement or cladding								
Non-metal frame	1.20	0.75	0.65	0.40	0.35	0.35	0.35	0.35
Metal framing with or without thermal break								
Curtain wall/storefront	1.20	0.70	0.60	0.50	0.45	0.45	0.40	0.40
Entrance door	1.20	1.10	0.90	0.85	0.80	0.80	0.80	0.80
All other metal frame	1.20	0.75	0.65	0.55	0.55	0.55	0.45	0.45
Maximum SHGC								
All vertical fenestration	0.25	0.25	0.25	0.40	0.40	0.40	0.45	0.45

Florida *Commercial* Energy Code

C101.4 Applicability. Where, in any specific case, different sections of this code specify different materials, methods of construction or other requirements, the **most restrictive shall govern.** Where there is a conflict between a general requirement and a specific requirement, the specific requirement shall govern.

Florida *Commercial* Energy Code

C106.1.1 Conflicts. Where conflicts occur between provisions of this code and referenced codes and standards, **the provisions of this code shall apply.**

C106.1.2 Provisions in referenced codes and standards. Where the extent of the reference to a referenced code or standard includes subject matter that is within the scope of this code, **the provisions of this code, as applicable, shall take precedence over the provisions in the referenced code or standard.**

Florida *Commercial* Energy Code

C106.2 Conflicting requirements.

Where the provisions of this code and the referenced standards conflict, the provisions of this code shall take precedence.

How Do Windows and Doors Meet This Criteria?

C303.1.3 Fenestration product rating. *U*-factors of fenestration products (windows, doors and skylights) shall be determined in accordance with NFRC 100 by an accredited, independent laboratory, and labeled and certified by the manufacturer. Products lacking such a labeled *U*-factor shall be assigned a default *U*-factor from table C303.1.3(1) or C303.1.3(2). The solar heat gain coefficient (SHGC) and *visible transmittance* (VT) of glazed fenestration products (windows, glazed doors and skylights) shall be determined in accordance with NFRC 200 by an accredited, independent laboratory, and labeled and certified by the manufacturer. Products lacking such a labeled SHGC or VT shall be assigned a default SHGC or VT from Table C303.1.3(3)

Default Values

**TABLE 303.1.3(1)
DEFAULT GLAZED FENESTRATION U-FACTOR**

FRAME TYPE	SINGLE PANE	DOUBLE PANE	SKYLIGHT	
			Single	Double
Metal	1.20	0.80	2.00	1.30
Metal with Thermal Break	1.10	0.65	1.90	1.10
Nonmetal or Metal Clad	0.95	0.55	1.75	1.05
Glazed Block	0.60			

**TABLE 303.1.3(2)
DEFAULT DOOR U-FACTORS**

DOOR TYPE	U-FACTOR
Uninsulated Metal	1.20
Insulated Metal	0.60
Wood	0.50
Insulated, nonmetal edge, max 45% glazing, any glazing double pane	0.35

**TABLE 303.1.3(3)
DEFAULT GLAZED FENESTRATION SHGC**

SINGLE GLAZED		DOUBLE GLAZED		GLAZED BLOCK
Clear	Tinted	Clear	Tinted	
0.8	0.7	0.7	0.6	0.6

Florida Building Code, 5th
Edition (2014): Energy
Conservation

Temporary Label Determines Compliance



National Fenestration
Rating Council®

CERTIFIED

World's Best Window Co.

Millennium 2000+
Vinyl-Clad Wood Frame
Double Glazing • Argon Fill • Low E
Product Type: **Vertical Slider**

ENERGY PERFORMANCE RATINGS

U-Factor (U.S./I-P)

0.35

Solar Heat Gain Coefficient

0.32

ADDITIONAL PERFORMANCE RATINGS

Visible Transmittance

0.51

Air Leakage (U.S./I-P)

Manufacturer stipulates that these ratings conform to applicable NFRC procedures for determining whole product performance. NFRC ratings are determined for a fixed set of environmental conditions and a specific product size. NFRC does not recommend any product and does not warrant the suitability of any product for any specific use. Consult manufacturer's literature for other product performance information.

www.nfrc.org

Energy Star 6.0

January 1, 2015



Energy Star 6.0

**Was implemented
January 1st, 2015 except
for the Northern Zone
which will be delayed for
1 year.**

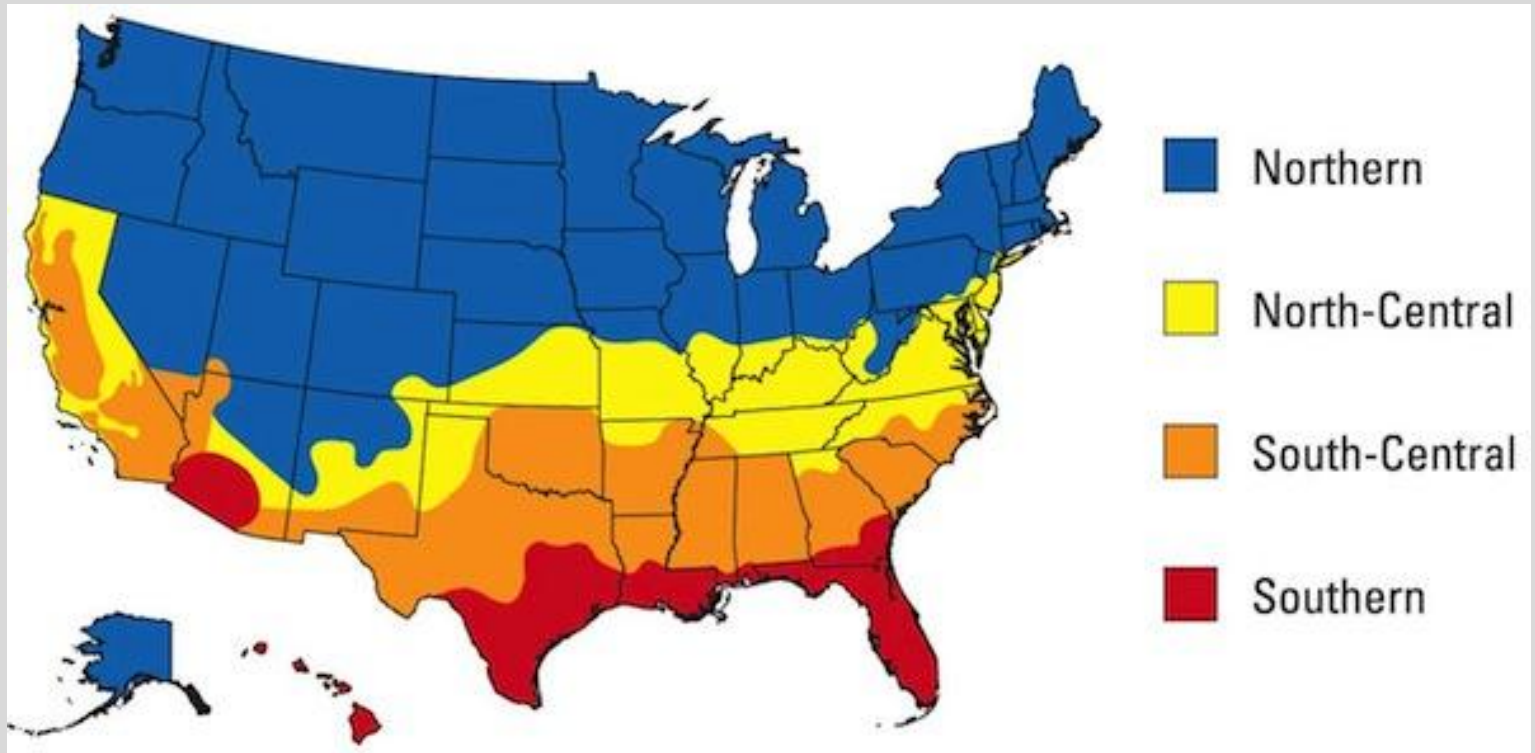

Energy Star 6.0

Energy Star will match the Florida Energy Code for Windows in Zone 2 in 2015

Previous Energy Star Criteria

6.0 Energy Star Criteria

Zone	U-Factor	SHGC
Northern	≤ 0.30	Any
Tradeoffs	$= 0.31$	≥ 0.35
	$= 0.32$	≥ 0.40
North-Central	≤ 0.32	≤ 0.40
South-Central	≤ 0.35	≤ 0.30
Southern	≤ 0.60	≤ 0.27

Zone	U-Factor	SHGC
Northern	≤ 0.27	Any
Tradeoff	$= 0.28$	≥ 0.32
North-Central	≤ 0.29	≤ 0.40
South-Central	≤ 0.31	≤ 0.25
Southern	≤ 0.40	≤ 0.25



Energy Star Windows

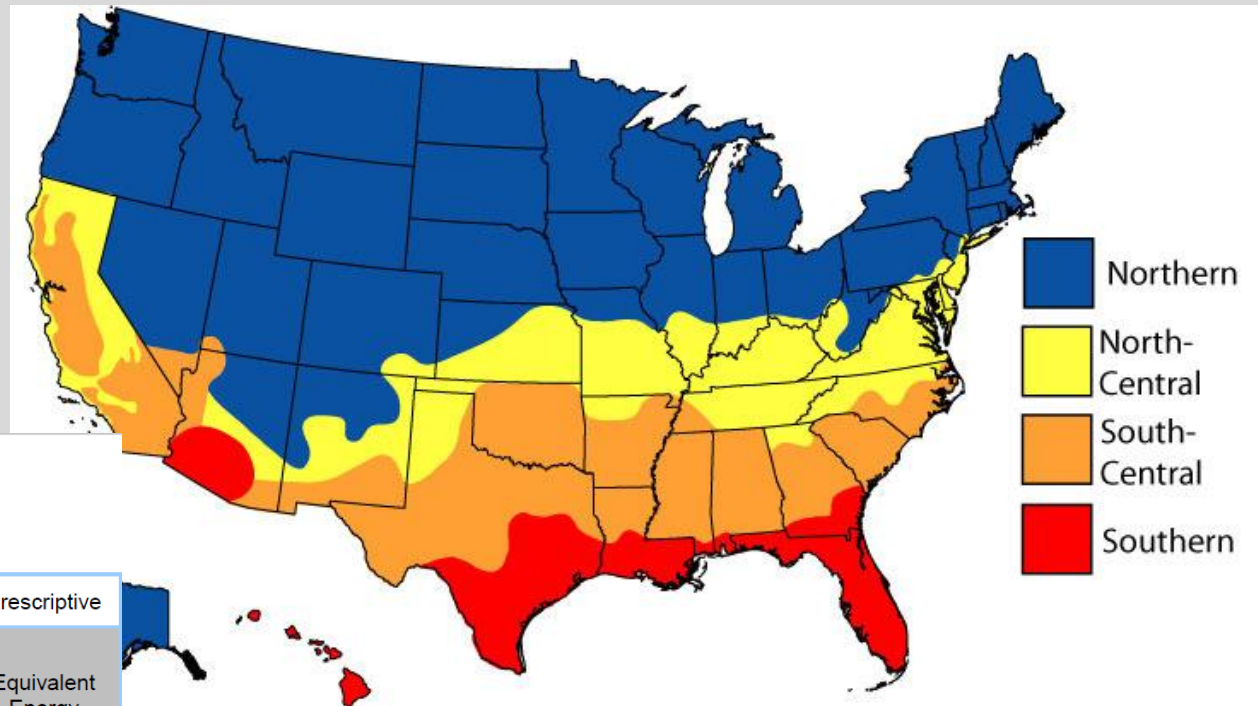

270

Windows

Climate Zone	U-Factor ¹	SHGC ²	
Northern	≤ 0.27	Any	Prescriptive
	$= 0.28$	≥ 0.32	Equivalent Energy Performance
	$= 0.29$	≥ 0.37	
	$= 0.30$	≥ 0.42	
North-Central	≤ 0.30	≤ 0.40	
South-Central	≤ 0.30	≤ 0.25	
Southern	≤ 0.40	≤ 0.25	

271 Air Leakage ≤ 0.3 cfm/ft²



Energy Star Doors

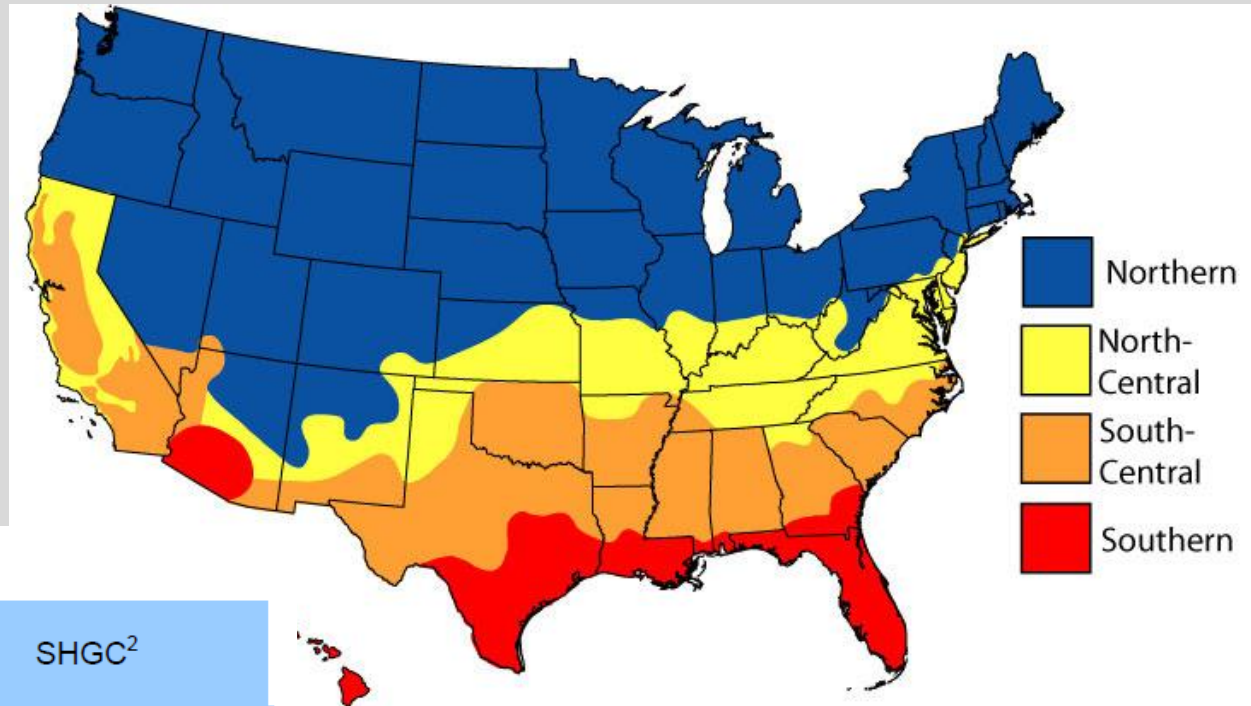

Doors

Glazing Level	U-Factor ¹	SHGC ²
Opaque	≤ 0.17	No Rating
$\leq \frac{1}{2}$ -Lite	≤ 0.25	≤ 0.25
$> \frac{1}{2}$ -Lite	≤ 0.30	Northern North-Central ≤ 0.40
		Southern South-Central ≤ 0.25

← Sliding Glass Door requirements



Air Leakage for Sliding Doors $\leq 0.3 \text{ cfm/ft}^2$
 Air Leakage for Swinging Doors $\leq 0.5 \text{ cfm/ft}^2$

Energy Star Comparison

ENERGY STAR as of 2014				
	Windows		Doors	
	U	SHGC	U	SHGC
N	=<.30	Any	=<.32	=<.30
	.31	>=.35	=<.32	=<.30
	.32	>=.40	=<.32	=<.30
NC	=<.32	=<.40	=<.32	=<.30
SC	=<.35	=<.30	=<.32	=<.30
S	=<.60	=<.27	=<.32	=<.30

ENERGY STAR 2015/2016*				
	Windows		Doors	
	U	SHGC	U	SHGC
N*	=<.27	Any	=<.30	=<.40
	.28	>=.32		
	.29	>=.37		
	.30	=>.42		
NC	=<.30	=<.40	=<.30	=<.40
SC	=<.30	=<.25	=<.30	=<.25
S	=<.40	=<.25	=<.30	=<.25

Energy Star requirements for U-factor and Solar Heat Gain Coefficients are getting tighter across the country. *Northern requirements go into effect in January 2016, a year after the rest of the country's requirements roll out in January 2015.

www.floridabuilding.org

- State Product Approvals

www.buildingcodeonline.com

- Dade approved products



www.approvalzoom.com

www.disastersafety.org

- IBHS website (Insurance Institute for Business & Home Safety)

www.flash.org

- FLASH website (Federal Alliance for Safe Homes)

www.inthpa.com

- International Hurricane Protection Association
- Approved Product Information

www.epa.gov/lead/index.html

- Renovation, repair & painting

<http://www.atcouncil.org/windspeed/>

- A great website for determining windspeed

Thank you for your time.

Are there any questions?