

1 1ST FLOOR BATHROOM  
SCALE: 1/2" = 1'-0"

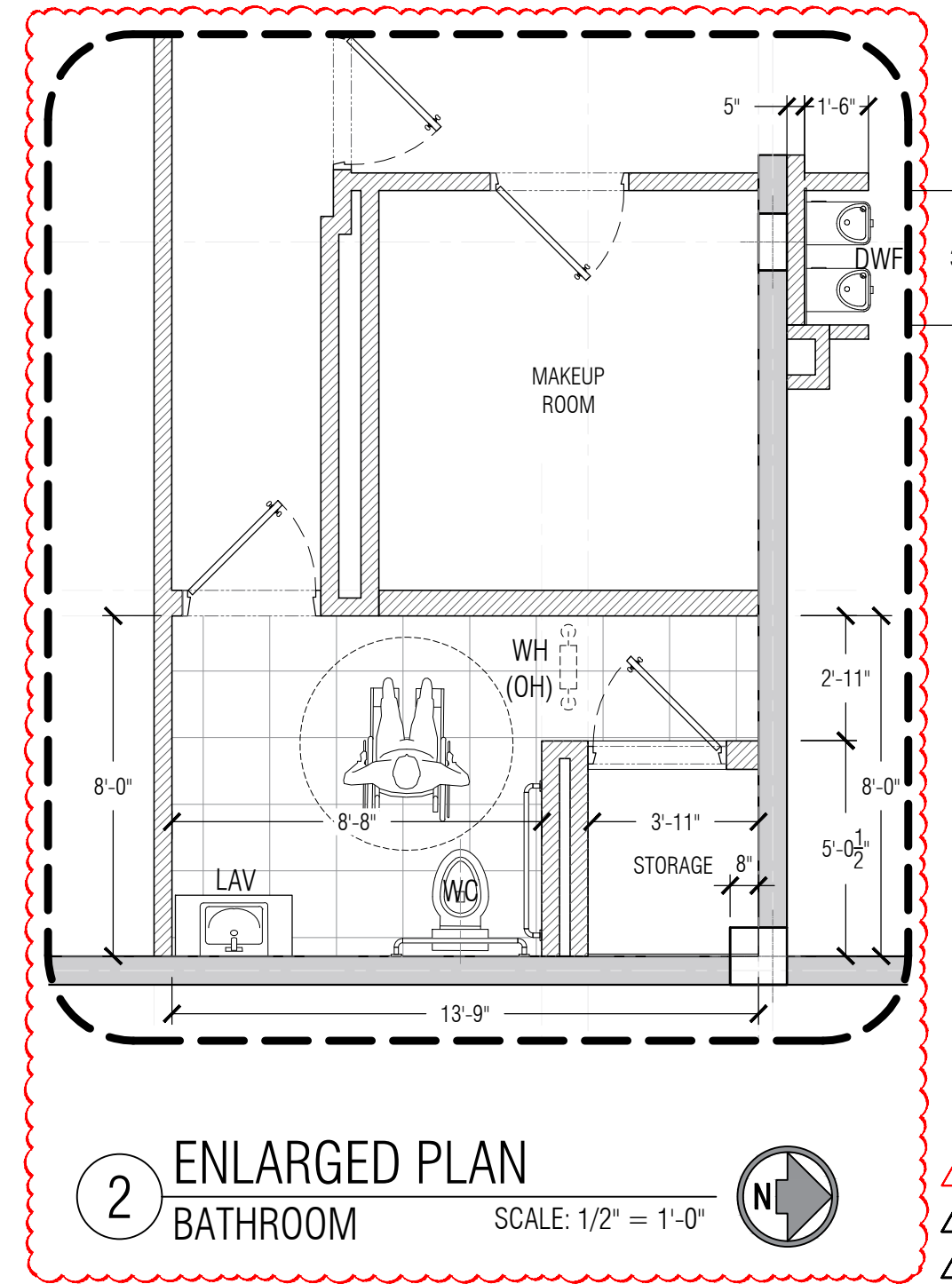

2 ENLARGED PLAN  
BATHROOM SCALE: 1/2" = 1'-0"

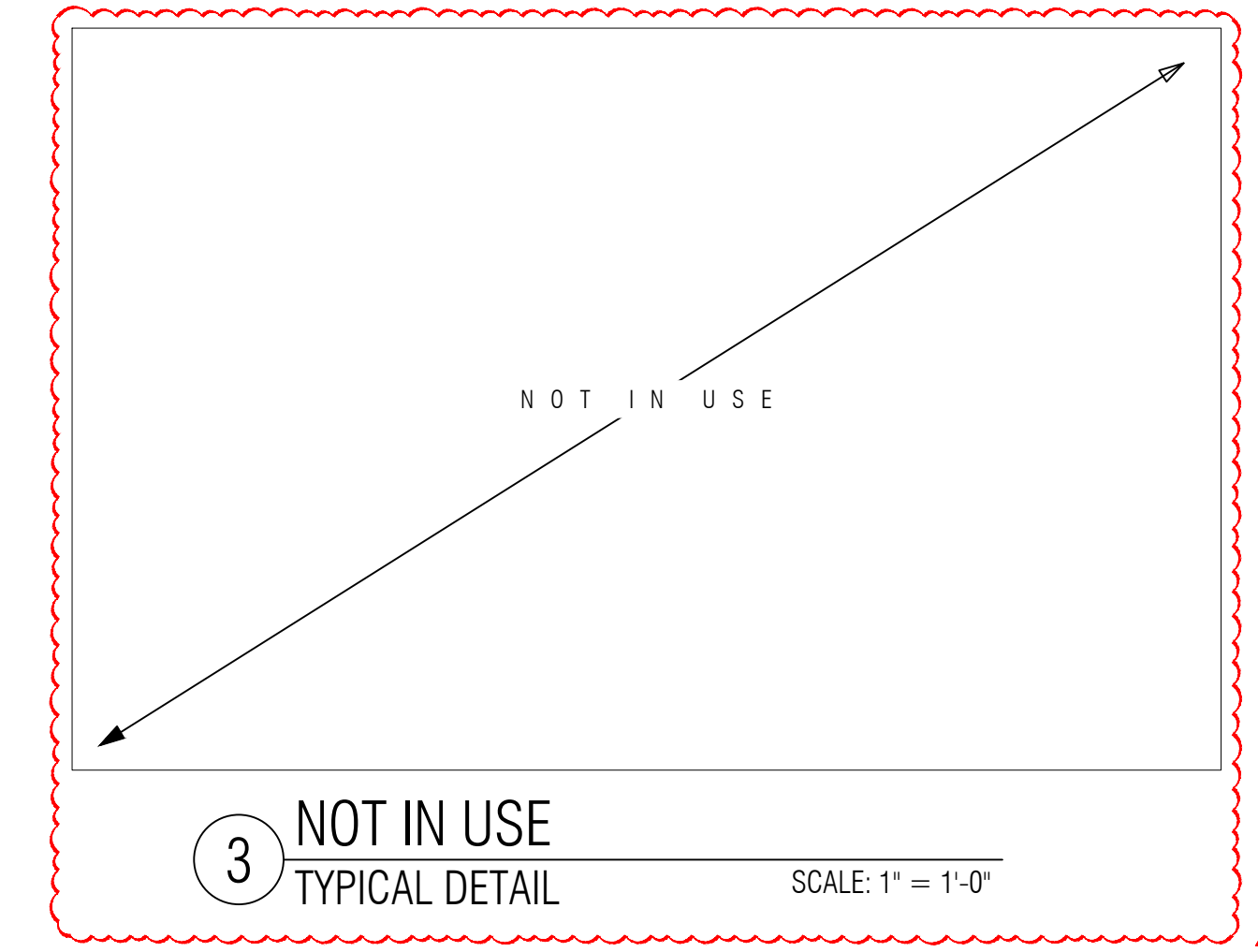

3 NOT IN USE  
TYPICAL DETAIL SCALE: 1" = 1'-0"

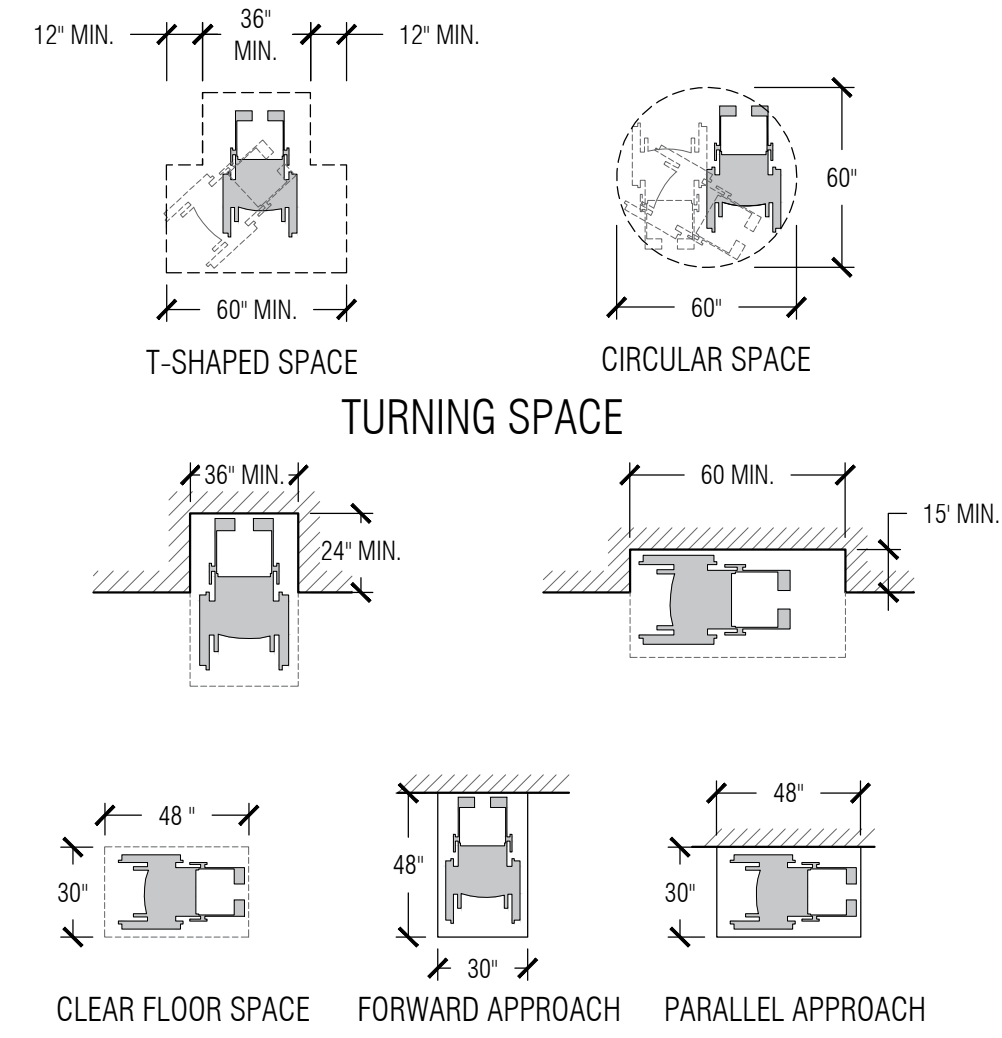

A MINIMUM CLEAR FLOOR SPACE  
N.T.S.

- CLEAR FLOOR SPACE NOTES:
- DOOR SHALL BE PERMITTED TO SWING INTO TURNING SPACES.
  - ONE FULL UNOBSTRUCTED SIDE OF THE CLEAR FLOOR SPACE MUST ADJOIN AN ACCESSIBLE ROUTE OR ANOTHER CLEAR FLOOR SPACE.
  - A CLEAR FLOOR SPACE IS REQUIRED AT ANY DEVICE WITH AN OPERABLE PART.

2020 FBC, A, 7TH EDITION

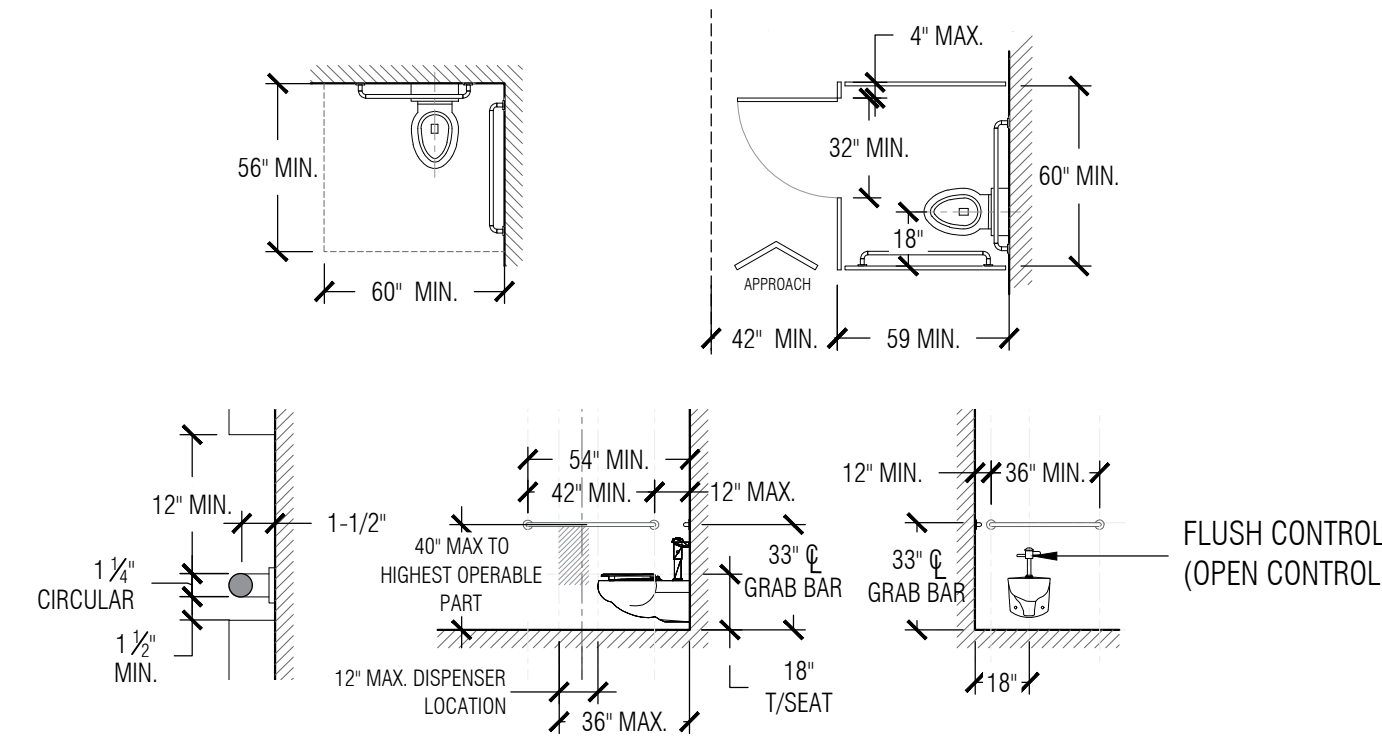

B TOILET ROOM CLEARANCES & MOUNTING HEIGHTS  
N.T.S.

- TOILET ROOM NOTE:
- A TURNING SPACE PER SECTION 304 IS REQUIRED WITH 306 SHALL BE PROVIDED.
  - FLUSH CONTROLS SHALL BE LOCATED ON THE OPEN SIDE OF THE WATER CLOSET.
  - LAVATORIES SHALL HAVE A CLEAR FLOOR COMPLYING WITH 305 POSITIONED FOR FORWARD.
  - INSTALL GRAB BARS TO TO WITHSTAND NOT LESS THAN A 250 POUND FORCE APPLIED AT ANY POINT ON THE BAR.

2020 FBC, A, 7TH EDITION

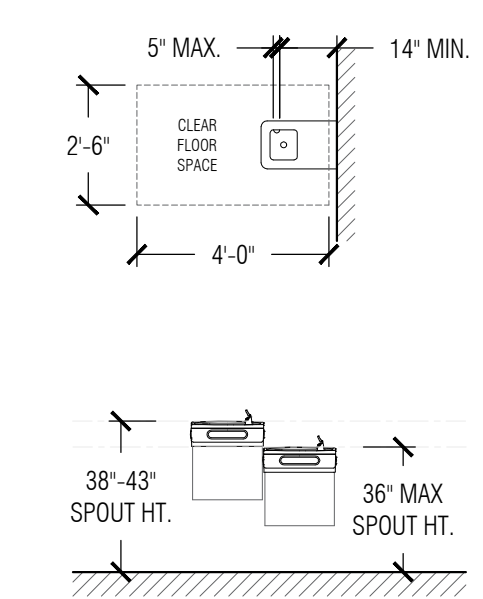

C DRINKING FOUNTAIN SPOUT LOCATION  
N.T.S.

- DRINKING FOUNTAIN NOTES:
- KNEE & TOE CLEARANCE COMPLYING WITH 306 SHALL BE PROVIDED.
  - WHERE A DRINKING FOUNTAIN IS REQUIRED, TWO SHALL BE PROVIDED: ONE HIGH AND ONE LOW.
  - UNITS SHALL HAVE CLEAR FLOOR SPACE COMPLYING WITH 305 POSITIONED FOR FORWARD APPROACH AND CENTERED ON UNIT.

2020 FBC, A, 7TH EDITION

ISSUE	DATE
2. CITY OF MIAMI COMMENTS	11/04/2022
3. CITY OF MIAMI COMMENTS	12/23/2022
4. CITY OF MIAMI COMMENTS	01/12/2023

AMERICANO  
MEDIA GROUP  
STUDIO  
2920 NW 7 ST  
MIAMI, FL 33125

PROJECT:  
INTERIOR REMODELING

BATHROOM  
ENLARGED  
PLAN & DETAILS



7875 NW 12th Street, Ste. 101  
Doral, FL 33126  
(786) 762-2204  
www.ves-us.com  
C.A. #32810

FELIX F. RODRIGUEZ, PE, SE  
FLORIDA PE #74481  
Civil, Structural, Mechanical  
admin@ves-us.com

VDES PROJECT #220078

DATE  
08/15/2022

SHEET  
A-13