



METAL ROOFING • METAL BUILDINGS • POLE BARNs • MINI STORAGEs

DETAIL MANUAL

and guide to Reed's Metals products



Perma-Loc & Secure-Seam Standing Seam Roofing Panels & Accessories

SALES AND MANUFACTURING LOCATIONS

Brookhaven, MS
19 E. Lincoln Drive NE
Brookhaven, MS 39601
601-823-6516

Lake Charles, LA
1909 Ruth Street
Sulpher, LA 70663
337-625-5051

Tupelo, MS
120 Industrial Park Rd
Saltillo, MS 38866
662-869-7797

Benton, AR
12655 I-30 South
Benton, AR 72015
501-776-3825

Jackson, TN
1070 S Highland Ave.
Jackson, TN 38301
731-300-3200

Holden, LA
5321 Arundel Rd
Meridian, Ms 39307
601-482-1500

Jasper, TX
3931 Hwy 96 S
Jasper, TX 75951
409-384-5777

Scott City, MO
1616 E. Rd.
Scott City, MO 63780
573-803-4700

Reed's Metals Standing Seam Roofing Panels

Reed's Metals is happy to offer the addition of three styles of Standing Seam roofing to its other popular lines of roofing panels. Standing seam, the Cadillac of roofing panel systems, offers the advantage of a completely hidden fastening system, eliminating the worry that sometimes accompanies the exposed fasteners of other styles of roofing.* Formed from 26 gauge AZ-50 Galvalume coated steel, coated with the best paint system available in any

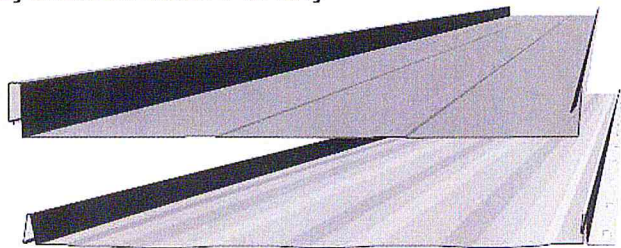

Fig. 2 The *Secure-Seam* panel (top) features 1 $\frac{3}{4}$ " ribs and mounts with special clips; the 1" high *Perma-Loc* "nail-strip" panel (bottom) is our most popular standing seam panel. The "rib" profile is shown on the upper panel, the "striation" profile on the lower.

features approximately one-inch high ribs and net panel coverage of either 12 or 16 inches. The "nail strip" and screws that attach each panel are in turn covered by each subsequent panel as each overlapping panel locks in place over the previous one (see Fig. 5). The **Secure-Seam** panel also uses a locking rib feature, but offers a 1 $\frac{3}{4}$ -inch rib that attaches with specially designed clips. It comes in widths of 14, 16, and 20 inches.

Both styles of standing seam panel are available with either striations or ribs, either of which affords an attractive appearance according to the tastes of the customer. Consult Figure 2 for the profile you would like for your standing seam roof.

roofing, and with the added advantage of on-site panel manufacture (our most common arrangement for sale), we believe our product to be the best and most affordable of its kind in the Central And Southeastern U.S

Reed's Metals standing seam roofing comes in two styles, and each style is available in either of three distinct profile patterns. **Perma-Loc** is our most popular and economical standing seam panel style.

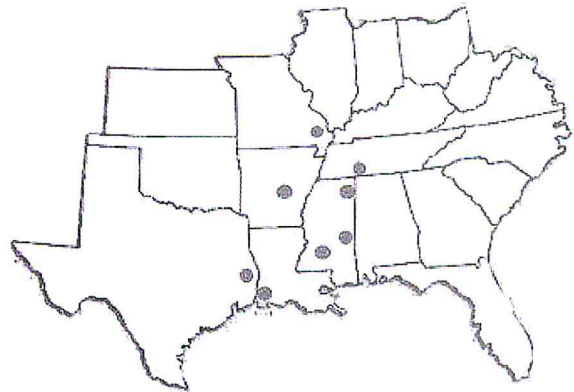

*Serving the Central
and Southeastern U.S*

* Any Roofing system with exposed fasteners can be applied leak-proof if installed properly. We recommend employing only proven and reputable roofing installers.

Customer Satisfaction is our TOP PRIORITY! . . .

a credo we live by at Reed's Metals. We manufacture and deliver to your specifications and greatly appreciate the opportunity to serve you.

Reed's Metals standing seam roofing is available in either 25-year acrylic-coated or any of over 20 colors, comprising of 40-year low gloss .7 to .9 mil full strength 70% Kynar 500/Hylar

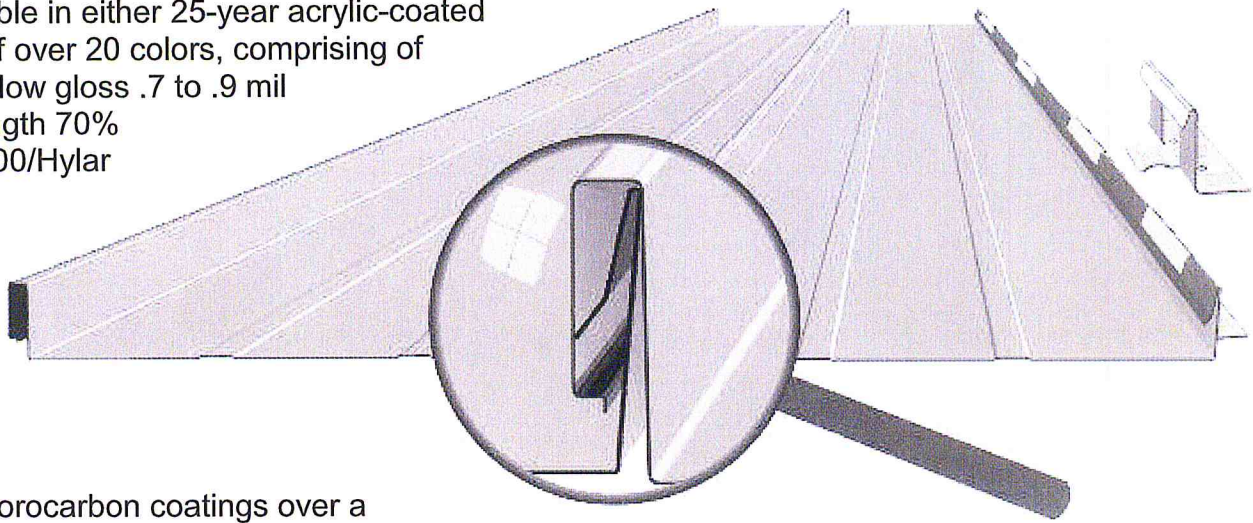

Fig. 4 Secure-Seam panels showing lap details and placement of UL-90 clips.

5000 fluorocarbon coatings over a urethane primer of .2 to .3 mil on the finish side, with primer and washcoat on the reverse side. Metallic coatings are also available and carry the same 40-year warranty. We manufacture both stock and custom trims and flashings, and provide screws and other accessories specific to standing seam installation (see back page).

Reeds Metals, recommends the convenience of on-site manufacturing with our portable roll-former. Delivery or customer pick-up of crated panels is also available at our facility.

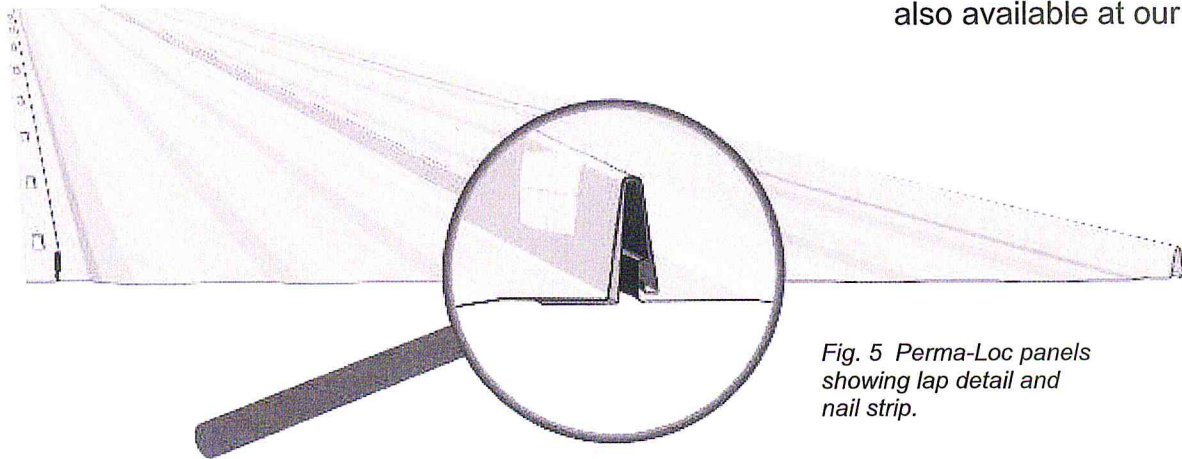

Fig. 5 Perma-Loc panels showing lap detail and nail strip.

While there are many possible trim and attachment solutions in the application of standing seam roofing, the Reeds Metals sales team endorses the methods shown in this manual as being among the best recommended in the standing seam industry. We are glad to offer our advice, suggestions, or comments to those who prefer variations of these procedures. We cannot endorse methods that are unfamiliar to the industry, however, and can only support those which meet the standards of engineering that have been passed in controlled tests, or have been shown reliable by experienced contractors.

Standing Seam Trim

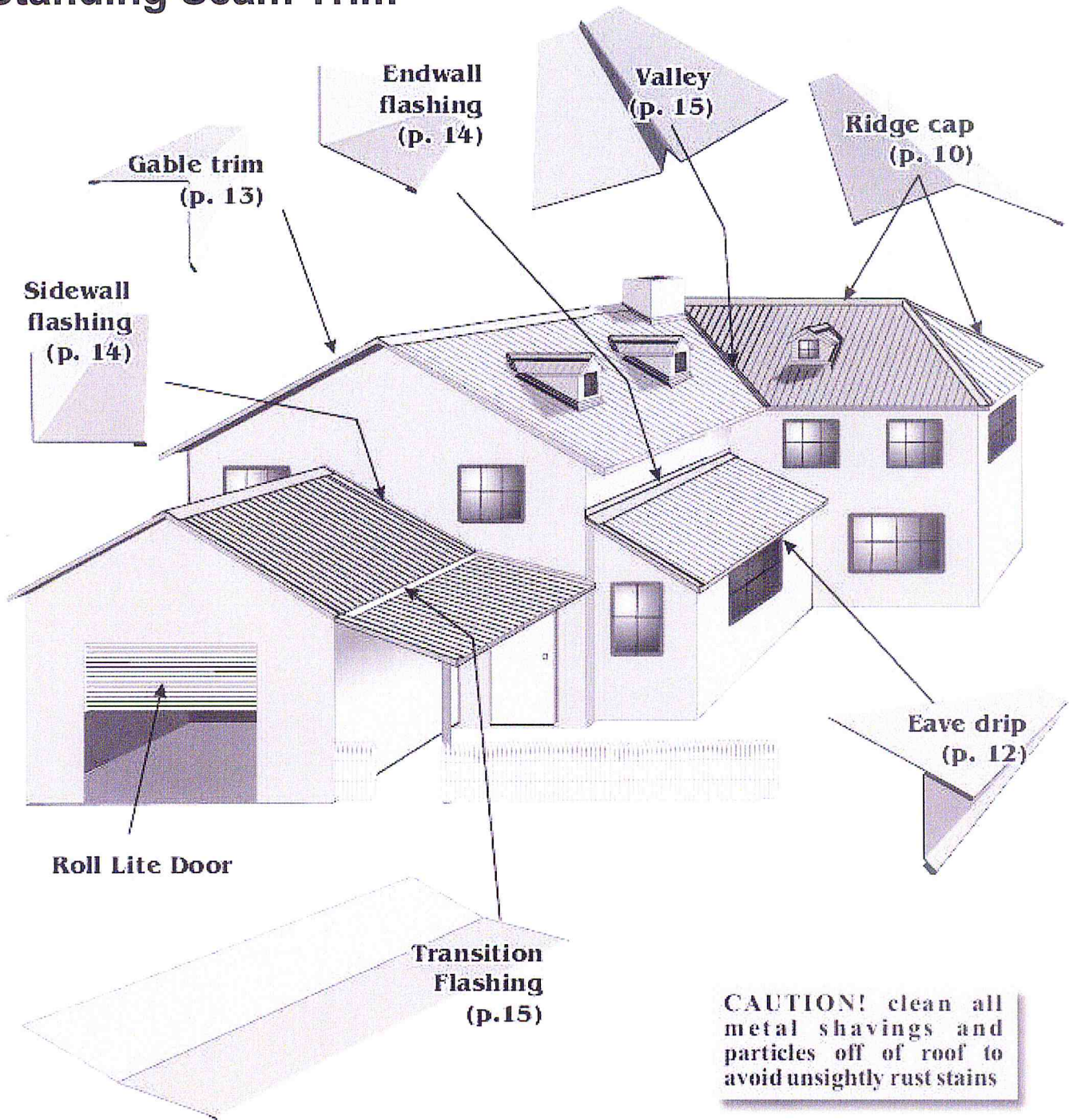

Fig. 6 Roofing trim and flashings are named by the location or function of that particular piece on the building

Installation of Panels

Roof Pitch

Mississippi Building Code requires a minimum pitch of 2/12 for the 1¾" **Secure-Seam**, and 3/12 pitch for the 1" **Perma-Loc**, to ensure proper water drainage. This means that the minimum roof slope required for all panels is either 2 or 3 inches of rise per foot, depending on which profile you choose. Consult our representative for recommendations for your particular roof pitch, and about roofing options if you have less than either of these minimums.

Ordering and Applying Trim

The most common flashing for standing seam roofing is the ridge cap, which is used at the peak of a roof where two opposing roof slopes join, and attaches to the roof with z-flashing. Other flashings that attach with z-flashing include transition flashing (which also requires panel starter), end wall and sidewall flashings. Panel starter is required to attach panels over valleys. Eave flashings include gable flashing, which runs up the sloped ends of the roof, and eave drip, which trims out the lower ends of the panels and provides a surface for the attachment of the lower end of the panel. Both gable flashing and eave drip are often applied above fascia trim, and may be attached with either surface screws or hidden eave cleats. For details about the application of each type of trim, see the details provided on pgs. 10-15.

Roof pitch must be given when ordering ridge caps, endwalls, valleys, and eave drip. When a steeper roof slope meets a lesser slope, both slopes should be mentioned when ordering transition flashing.

Dormer Detail

Fig. 7 Most of the basic standing seam trims are used on dormers. The bottom corners of the dormer are similar to the placement of sidewall and endwall flashings on chimneys. All but valleys and eave drip require z-flashing; valleys require panel starter, and eave drip may be screwed or fastened with eave cleats.

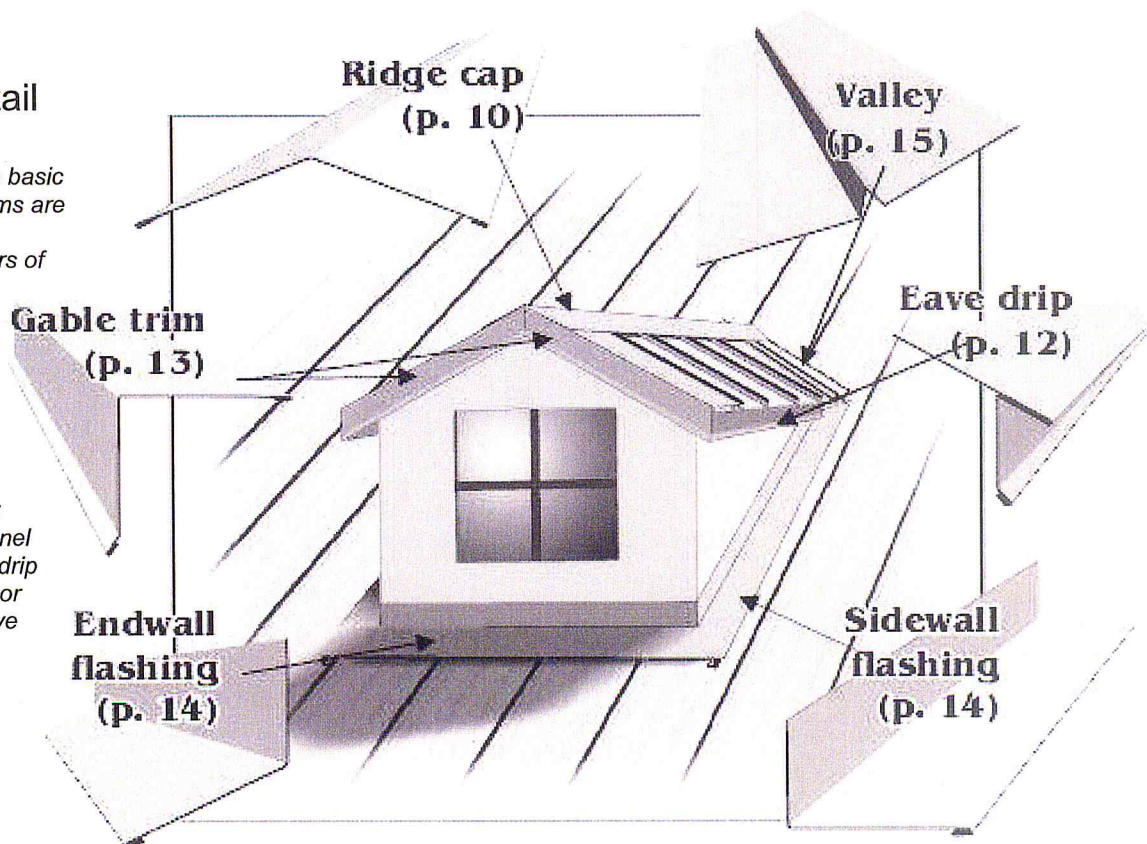

General Principles of a Typical Installation – Hidden Fastener System

Except for only a few differences, the high-rib **Secure-Seam** panels and the low-rib **Perma-Loc** panels are installed in the same general fashion. Where pancake screws are applied to the “nailstrip” of the **Perma-Loc**

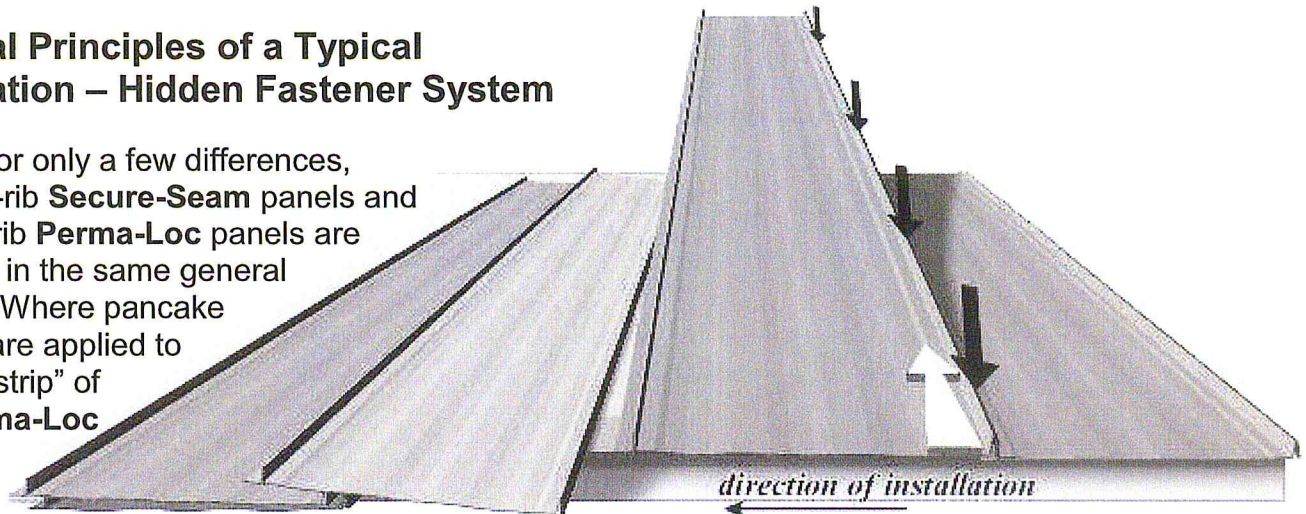

Fig. 8 Each Panel should be installed over the extended eave drip, pressed down and attached with the appropriate fasteners, and eave hems finished before installing the next panel.

panel, special clips (that require 2 screws each) are used for the **Secure-Seam** panel. When used, extended eave drip should be installed first along the drip edge of the roof. The lower end of each panel is then trimmed and the hem pre-bent before installation (see p. 12). The starter panel is laid out with the overlap side against an eave or wall and the hem pulled up tight and then compressed around the eave drip. The “nailstrip” (or clips, in the case of **Secure-Seam**) is screwed off completely with pancake screws before the next panel is installed. Care should be taken that the starter panel is square with the roof, since the first panel determines the lay of all that follow it.

The pre-bent eave end of the next panel is then pulled tight against the eave drip and pressed or “walked” down over the first panel, its nailstrip secured, and the next panel applied, and so on. Each panel is always screwed off and the hem finished before installing the next. The unfastened length against the gable or wall is secured (then or later) with z-flashing and either gable rakes (on the gable eave) or sidewalls (against a wall).

Ordering Roof Panels and Screws

Care should be taken to order panels of the correct length to avoid having to make corrective measures after purchase. Panel lengths should fall 2 to 3 inches short of the ridge when a vented ridge is desired, and should be ordered to extend 2½ inches past the eave when being attached to extended eave drip (see p. 9). The Reed’s Metals sales personnel are ready to assist customers with information specific to their particular roof.

Special, flat-headed screws called pancake screws are used to attach either nail strip panels or the clips that secure the locking panels. Woodgrip pancakes are used when going into wood decking, or self-drilling pancakes for going into metal purlins. The same screws also secure attachment flashings like z-flashing, panel starter, and eave cleats. 1/8-inch stainless rivets are recommended for attaching ridge caps, endwall and sidewall flashings, transition flashings, and any other flashings that attach to z-flashing. See page 9 for more information on screw spacing and ordering.

On Perma-Loc (nailstrip) panels, screws should be centered in slot and should not be tightened completely to allow for panel expansion.

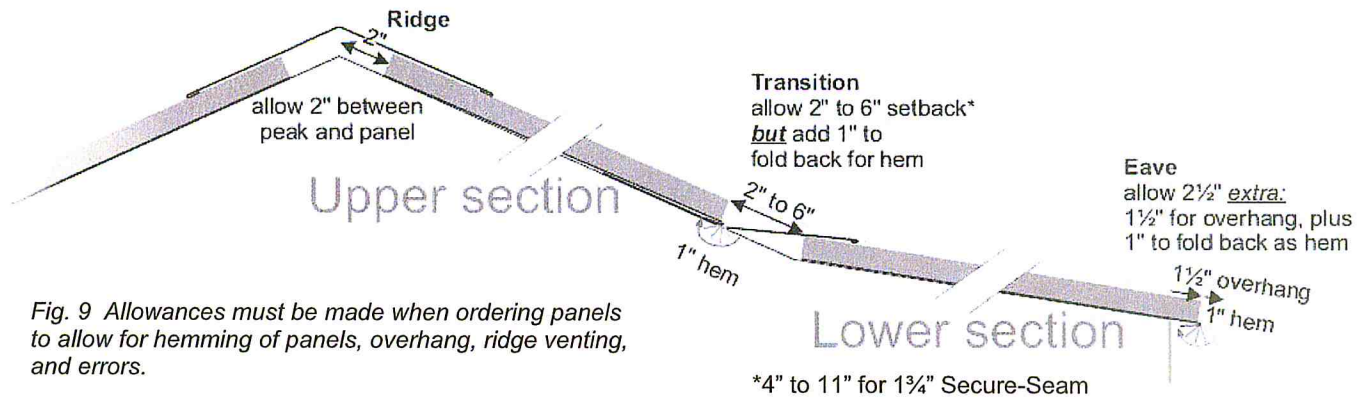

Fig. 9 Allowances must be made when ordering panels to allow for hemming of panels, overhang, ridge venting, and errors.

Since allowance must be made in the hidden fastener system for hemming panels that attach to extended eave drip (see p. 12), these panels should be ordered approximately 2 1/2" longer than the substrate decking to allow panel length for the 1 1/2" nose on extended eave drip plus the 1" hem. Likewise, panels ending in valleys should be ordered 1" longer for hemming, but with allowance made for a 3 or 4" passageway between the panel and the valley diverter to allow for the flow of water (subtract 3 or 4").

Where the deck makes a transition from a higher to lesser pitch, lower panels should be ordered from the transition point downward allowing for eave drip (as above), and upper panels must allow for a setback away from the transition point depending upon the roof pitch, the less the difference in pitch, the greater the setback, and the more the need for a longer length on the lower side of the transition flashing (see p. 15 for details).

The general principles of attaching the upper and lower edges of standing seam roofing are most thoroughly covered in the sections on "Eave drip"(p. 12) and "Ridge caps" (p. 10).

Trimming and Cutting Steel Panels

The best devices for cutting steel panels across the profile are circular saws, nibblers, and various shear attachments for drills. Hand operated snips also work. Nibblers, and especially Carborundum blades on electric saws, however, do have a tendency to either leave hot metal particles that can burn paint surfaces or leave rust marks on panels and trim. The same is true of any filings left on the roof caused by the application of screws. Care should be taken to brush all such particles from roof surfaces immediately after application.

To cut panels lengthwise: Note carefully where the panel is to be cut, and, using a straightedge, score deeply down the length of the panel with a sharp-pointed utility knife. Folding the panel along the score mark, and bending back again if necessary, should produce a clean break in the panel.

Keep Materials Dry!

Paint and finishes of Reed's Metals' panels and trim are designed to withstand severe rain and wet weather conditions. Neither painted, galvanized, or Galvalume finishes, however, are designed to be in continuous contact with water for long periods of time. Damage will result if uninstalled panels or trim are allowed to remain wet in storage. Be sure to store material that will not be installed immediately in a dry location. Wet material should be air-dried and re-stacked if installation is not planned right away.

How to Figure and Apply Screws Cleats, and Other Accessories

Standing seam roofing is particularly noted for its use of hidden fasteners. Pancake screws are used because they are strong and yet have a low profile that does not interfere with panel and trim installation. For nailstrip panels, one pancake screw is required every 10¼ inches, (every other slot), which comes out to 86 screws per 100 sq. ft of roof for 16 inch panels. This makes the number of screws necessary equal to the linear footage of the order times 1.15:

$$\# \text{ screws} = \text{linear ft of panels} \times 1.15$$

Since other panel widths make the total for the entire roof to vary, please confirm all estimates with your Reed's Metals representative when you place your order.

For Secure-Seam panels, one clip is applied every 2 feet, with 2 pancake screws holding each clip. This makes 38 clips and 75 screws per square of 16-inch roofing.

For solid decking, at least ½-inch structural plywood or OSB (5/8" for any high velocity wind zone of 120 and above) supported on rafters at a maximum of 24" on center is required.

Policies

All standing seam trim and panels are manufactured from 26-gauge prime coil stock, and is returnable as long as it is deemed by our company's representative as being in good, clean, resalable condition, free from scratches, mars, and other damage. The same general principle applies also to the return of other accessories such as screws, boots, closures, etc. Trim that is custom-made is not returnable, and is considered the property of the customer once it has been made, whether paid for or not. See below for details.

Delivery policy - Delivery charges apply to all orders where delivery is requested, as well as crating charges when crating is necessary. Please consult the Reed's Metals sales department for details.

Sales tax - All orders picked up at Reed's Metals, and all orders delivered within the state of Mississippi, are subject to state sales tax. Tax exemptions should be verified prior to delivery or customer pickup.

Warranted products - Painted standing seam panels come with a 40-year coil manufacturer's warranty, and unpainted Galvalume comes with a 20-year warranty. All trim is manufactured from the best grade in stock of the particular color ordered.

Indemnity - All prices and designs are subject to change without notice.

Disclaimer - While we have made every attempt at accuracy in this manual, we are not responsible for typographic, printing, or technical errors in this or any other publication.

Return Policy - All panel orders and special order (non-stock) trim are considered the property of the customer and non-refundable once they are manufactured. Only trim made from our normally stocked colors may be returned for a refund providing it is returned in a clean, resalable condition. Restocking charges may apply.

	Perma-Loc							
	z-flashing	eave cleats	panel starter	rivets	pancake screws	hemming top	butyl tape	caulk (tubes)
Ridge cap	2			16	30			2
Extended Eave drip		1			8	yes		
Gable trim	1	1		8	12		10'	
Sidewall	1			8	12		10'	
Endwall	1			8	15		10'	1
Transition flashing	1		1	8	23	yes	10'	1
Valley			2		12	yes	20'	

Fig. 10 Above chart is for a typical Perma-Loc roof with all hidden fasteners. For each type of trim on the left, the amount of the necessary accessory at the top of the chart is shown in each box. While caulk will work where butyl sealant is shown, we recommend butyl sealant on full lengths of trim because it is economical and easy to apply.

Fastening Schedule for Various Wind Speeds

			Wind Speed Zone			
			110 MPH	120 MPH	130 MPH	140 MPH
Roof Zone	Fastener Type A	Substrate	On Center Spacing	On Center Spacing	On Center Spacing	On Center Spacing
Zone 1	#10-12x1"	CDX*	10¼"	10¼"	10¼"	10¼"
Zone 2	#10-12x1"	CDX*	10¼"	10¼"	10¼"	5⅞"
Zone 3	#10-12x1"	CDX*	10¼"	10¼"	10¼"	5⅞"

* 15/32" CDX / 19/32" CDX

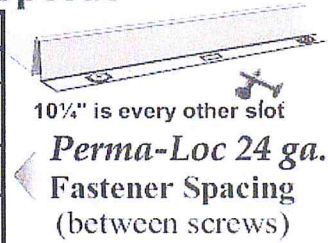

10¼" is every other slot
Perma-Loc 24 ga.
Fastener Spacing
 (between screws)



			Wind Speed Zone			
			110 MPH	120 MPH	130 MPH	140 MPH
Roof Zone	Fastener Type A	Substrate	On Center Spacing	On Center Spacing	On Center Spacing	On Center Spacing
Zone 1	#10-12x1"	CDX*	24"	24"	24"	24"
Zone 2	#10-12x1"	CDX*	24"	24"	24"	12"
Zone 3	#10-12x1"	CDX*	24"	24"	24"	12"

* 15/32" CDX / 19/32" CDX

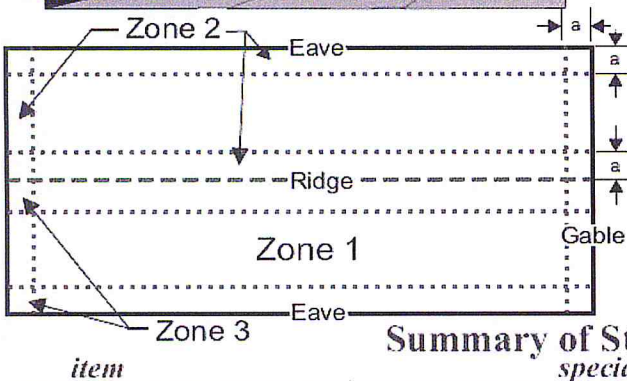

Fig. 23 Note: Dimension **a** is defined as 10% of the minimum width of the building, or 40% of the mean height of the roof, whichever is smaller; however, **a** cannot be less than either 4% of the minimum width of the building, or 3 feet.

Summary of Stock Trims and Flashings *special order information*

Ridge caps (RC-7)	State roof pitch when ordering. Also available in larger widths. Attached with Z-flashing (2 per ridge cap) and rivets.
Eave drip (ED-7, ED-8)	Specify roof pitch when ordering. ED-7 extended eave drip recommended (cleats necessary for hidden fastener installation.) Special tools required to attach panels. ED-8 requires exposed screws on panel.
Gable flashings (EF-7, EF-8, EF-9, EF-10)	Screwless and step rakes available. Cleats necessary for screwless rakes. Use butyl sealant between step rake and panel.
Valleys (PV-1)	Specify pitch when ordering. Panel starter necessary for hidden screw application. Butyl sealant used under starter.
Sidewall (SW-7, SW-8, SW-9, SW-10)	SW-7 & SW-9 (Secure-Seam) require Z-flashing and rivets. Use butyl sealant between SW-8 & SW-10 step sidewall flashings and panel.
Endwall (EW-7)	Specify pitch when ordering. Attaches with Z-flashing and rivets.
Transition flashing	Specify pitches of both roof sections. Attaches with Z-flashing and rivets (lower) and panel starter with pancake screws (upper).

Ridge Cap

The Ridge Cap is used to seal the upper point at which two slopes meet. This can be both along the ridge of the roof as well as the covering for a hip, as well as on the ridge of dormers.

Attachment to the roof is most generally accomplished through the use of z-flashing. Z-flashings are either notched or cut to length (to fit between panel ribs) and attached with screws to the roof through the panels. Ridge caps are in turn attached with rivets to the z-flashing. Whether the z-flashing is notched or cut to length, gaps between it and the panels should be kept to a minimum (no more than 1/4 inch) since the gap will be sealed with caulk.

Z-flashing must be sealed both beneath and where it butts against the panel ribs with Solar Seal 900® caulk or equivalent. Thus sealed, z-flashing forms a water-proof barrier to protect the roof peak from leaks from blowing rain. When used on a hip roof, z-flashing is cut or notched at whatever widths are appropriate for the pitch and cut of the hip.

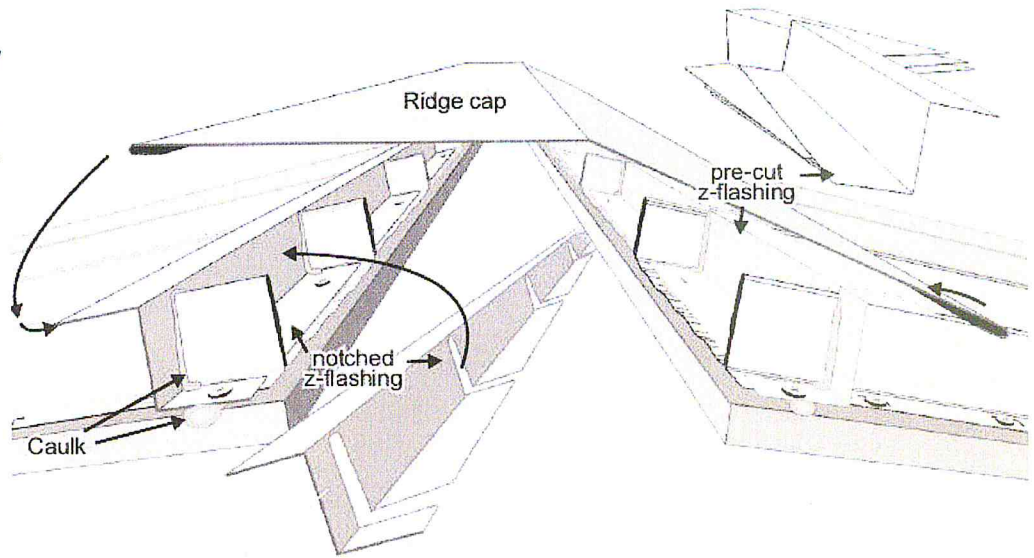

Fig. 11 To attach ridge caps, z-flashings are either notched (left) or cut into pieces (right) and mounted with screws at the upper ends of the panels. Caulk is applied on the bottom side and around the panel ribs to seal the ridge against rain. The mounted ridge cap is attached to the z-flashing with rivets.

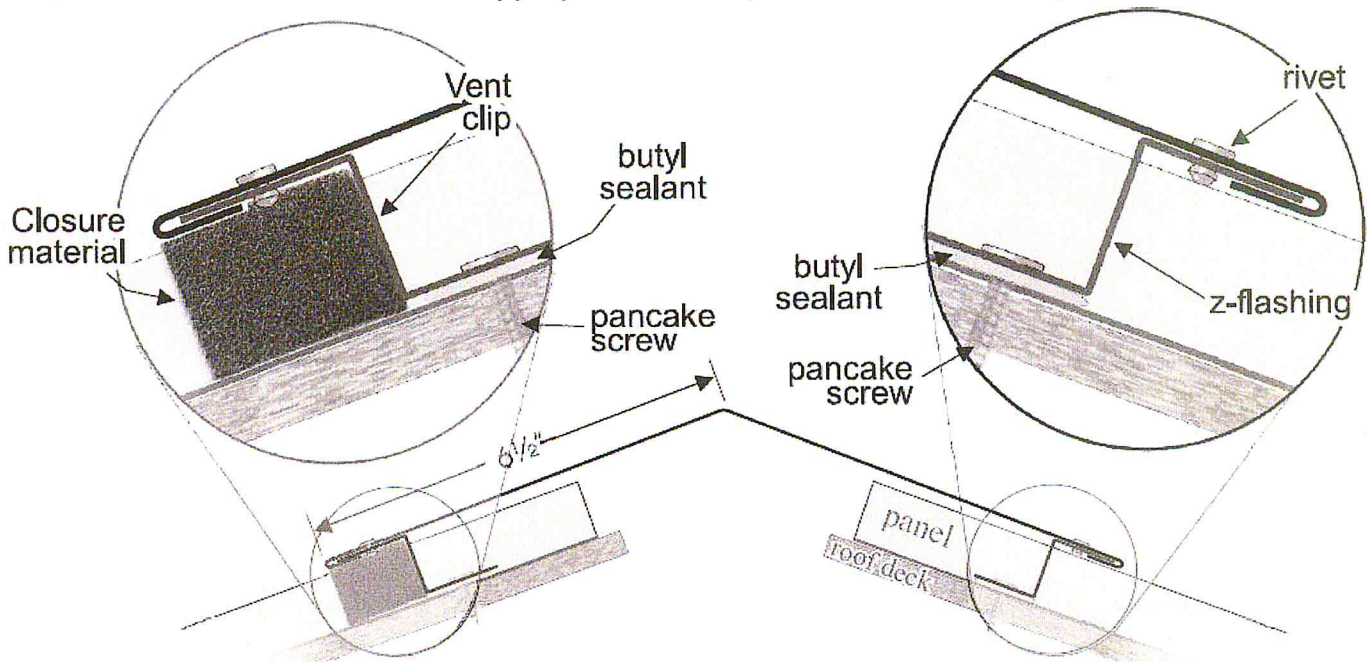

Fig. 12 Ridge caps can be installed as vented (using vent clips and vent material) or sealed (using Z-flashings), as shown also in Fig. 13

When attic ventilation is desired, vent clips can be used in the place of z-flashing. Vent clips straddle each rib, and support the ridge cap in much the same manner as the z-flashing. Closure material is inserted between the ribs and sandwiched between the panels and the ridge caps. The decking must, of course, be cut at the ridge to let out hot air.

Vent material must be cut to the proper length for installation. It is a sponge-like or fibrous material that prevents wind-driven rain, insects, and leaves and debris from entering the attic, while at the same time allowing the release of hot air out of the attic. Installation may require caulk to hold the material in place.

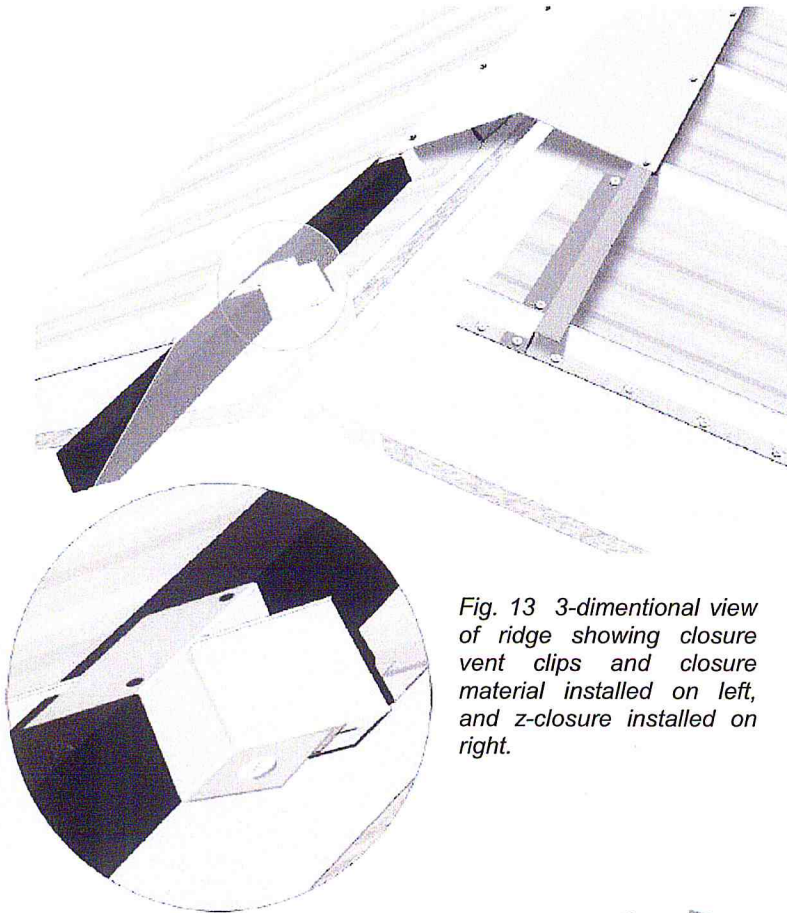

Fig. 13 3-dimensional view of ridge showing closure vent clips and closure material installed on left, and z-closure installed on right.

Attachment Flashings

Eave cleats allow the Hidden fastener system to Work with the eave drip and gable rakes. The factory-hemmed edge of the rake or eave drip fits around the “kick-out” of the cleat, which is attached to the fascia board with pancake screws.

Panel starter is used to attach the lower ends of hemmed panels over trim above the eave, as with valleys and transition flashing. It is attached with pancake screws and sealed beneath with butyl sealant.

Z-flashing is the basis for attaching five basic trims to the roof. When attaching ridge caps, transition flashing, and endwalls, z-flashing must be notched or cut to fit *between* panel ribs. When attaching gable trim and sidewalls, the z-flashing is not cut, but is mounted parallel to the ribs. Z-flashing must be attached with screws and, to prevent leaks, with butyl tape (or equivalent) underneath. Order ZF-7 for Perma-Loc, and EF-9 for Secure-Seam. For specifics, see each type of trim being attached.

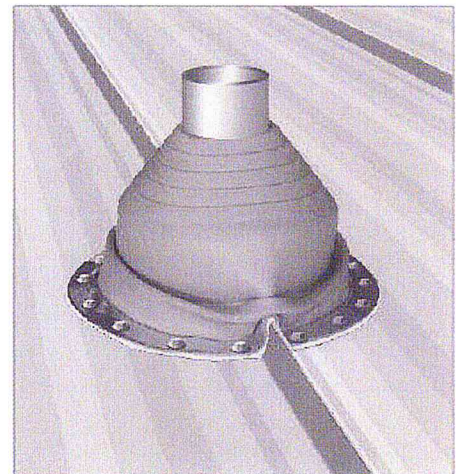
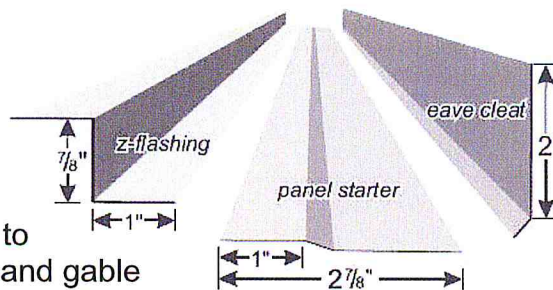

Fig. 14 Pipe Boots provide a watertight seal around roof vents and come in a variety of sizes. They seal with caulk under the base and around pipe, and conform to the shape of the panel ribs.

Eave Drip & Fascia

Fascia and extended eave drip provide a protective covering for the fascia boards and edges of roof decking at the drip eave of the building. Unlike conventional exposed fastener roofing, eave drip on the standing seam roof also acts as an anchoring device for the lower edges of the panels, allowing a continuation of the hidden fastener system all the way down to the soffit. Fascia are overlapped by eave cleats, which approximately line up with the roof edge of the decking, and are held in place by pancake screws. The extended eave drip has an open hem that hooks onto the cleat at its lower end, and is screwed to the decking on the roof side. Panels are trimmed in a specific manner (see diagram below), bent with a hemming tool, and crimped around the extended eave drip, securing the lower end of the panel. Screws applied to the "nail strip" of the Perma-Loc panel (or cleats and case of Secure-Seam panels) secure the rest of the length of the panel. The same hemming procedure applies to valleys and transition flashing, although these are attached to roof cleats instead of the "nose" of the extended eave drip.

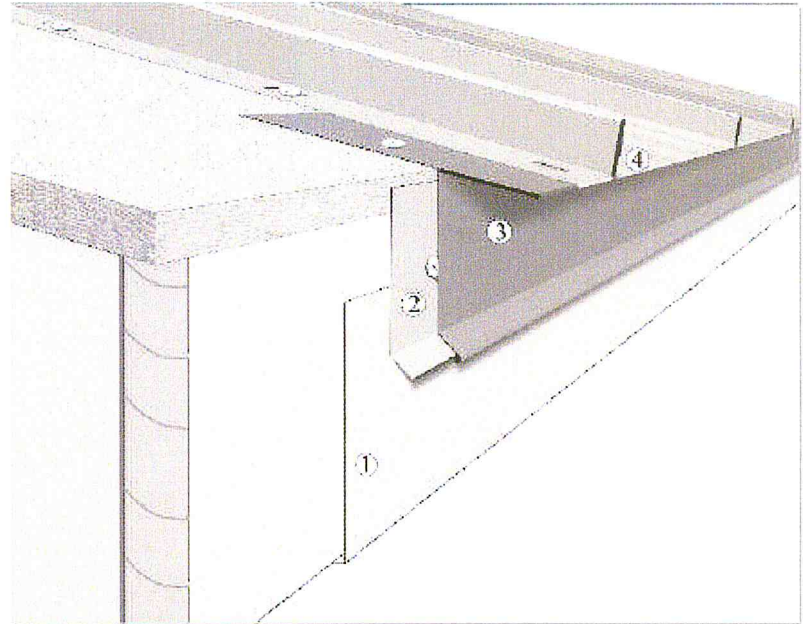

Fig. 15 Layered view of eave, showing fascia (1), cleat (2), extended eave drip (3), and panel (4). Note how the eave drip fits around the cleat, and how the cut panel (which is bent on site by the installer) fits around the "nose" of the eave drip (in actual use, extended eave drip must match color of panel).

See valleys and transition flashing (p. 15) for Specific details. When ordering care must be taken to specify the correct pitch of eave drip to avoid either unnecessary effort in applying the trim (if ordered too flat) or eave drip that stands out from the eave (if ordered

See valleys and transition flashing (p. 15) for Specific details. When ordering care must be taken to specify the correct pitch of eave drip to avoid either unnecessary effort in applying the trim (if ordered too flat) or eave drip that stands out from the eave (if ordered

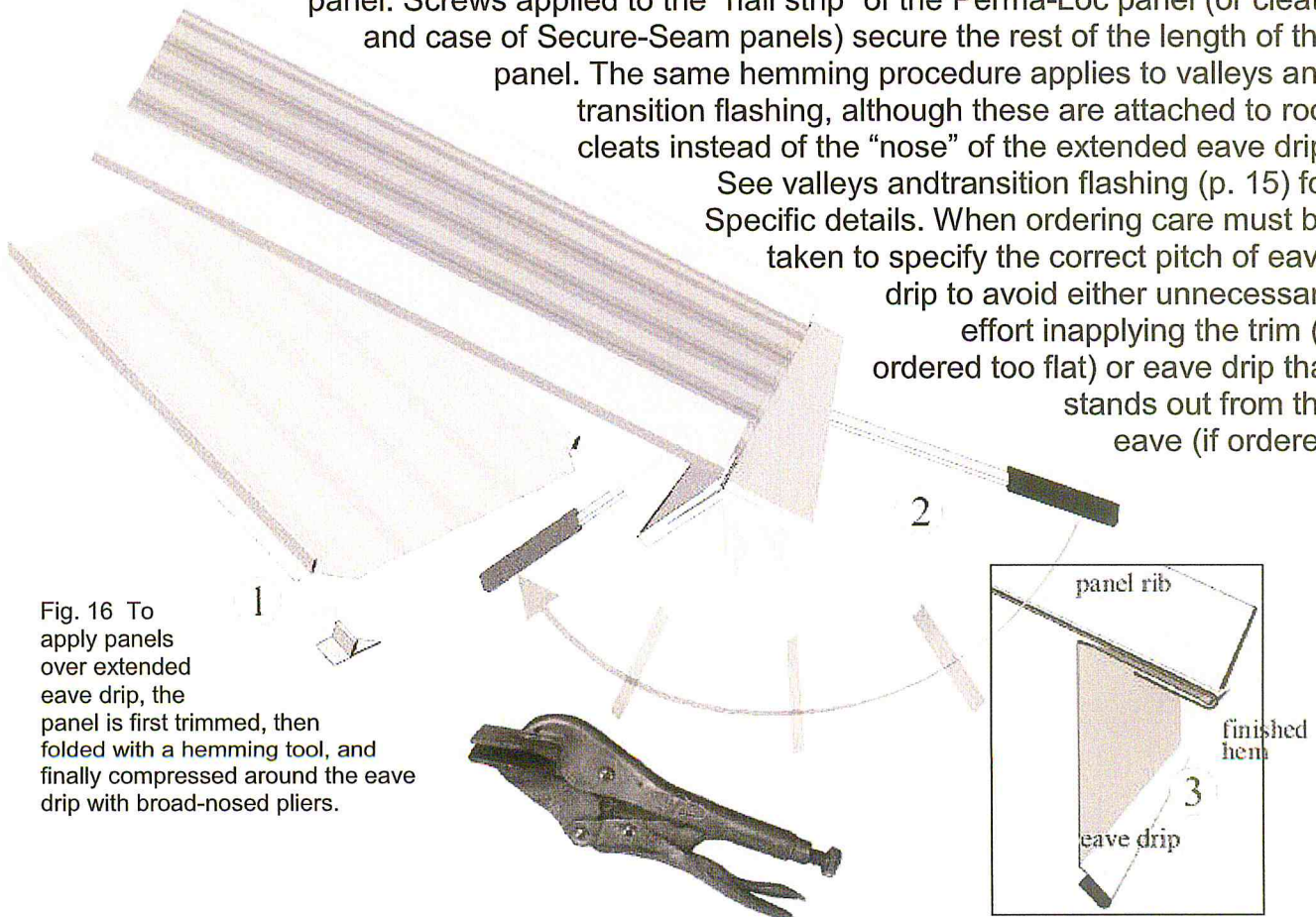
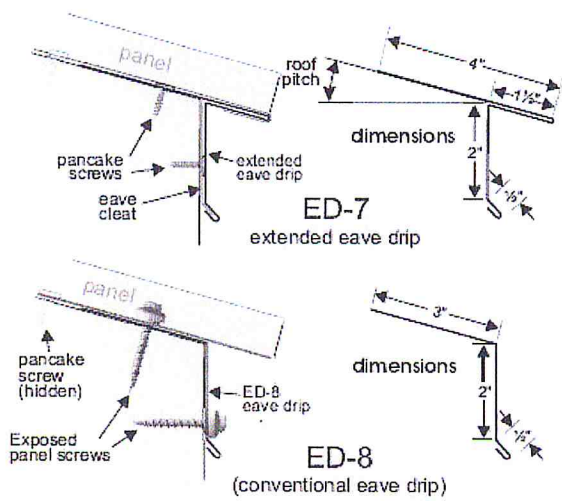

Fig. 16 To apply panels over extended eave drip, the panel is first trimmed, then folded with a hemming tool, and finally compressed around the eave drip with broad-nosed pliers.



too steep). If more than one pitch is involved, specify the number of each pitch (eave drip comes in 10-foot lengths). Order 90 degree eave drip for square-cut eaves.

While the hidden fastener system calls for eave cleats, exposed screws are a simpler and easier-to-install option for eave drip. Surface screws are simply installed at intervals along the face of the trim. Finally, while the remainder of the roof uses hidden fasteners, some installers elect to use screws in the conventional fashion along the eave only of the building. These simplifying procedures both reduce cost and allow faster application of the roofing.

Gable Flashing

Gable trim serves a similar purpose to eave drip, but acts mainly to protect the exposed edge of the gable end of the building from both wind and rain rather than to serve any function in anchoring panels. The attachment of the eave side has the same options described under Eave Drip and Fascia, with regard to cleats vs. exposed screws. For the hidden fastener system, the roof side must be attached to z-flashing that runs parallel to the panel ribs and is in turn fastened to the roof with screws and sealed with butyl tape or comparable sealant.

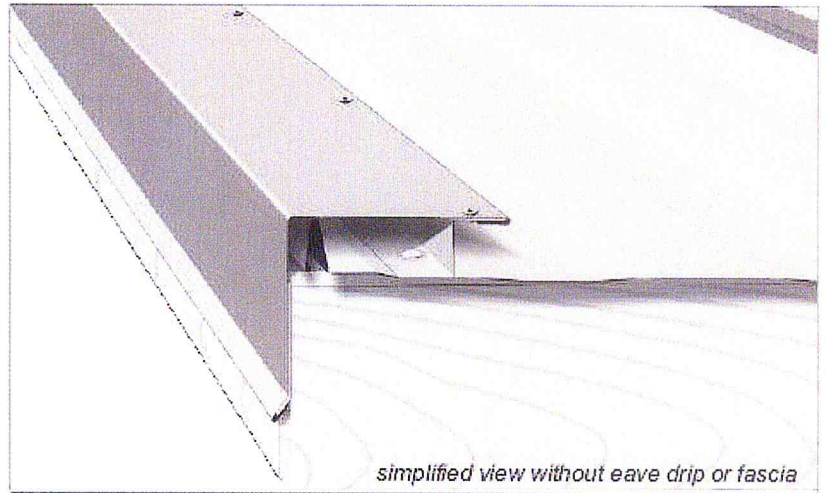
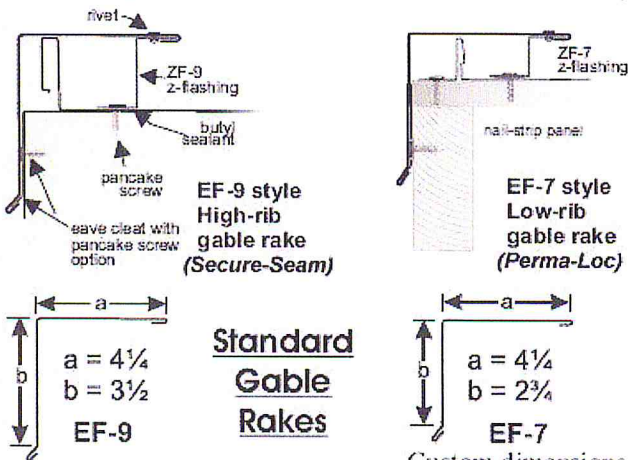
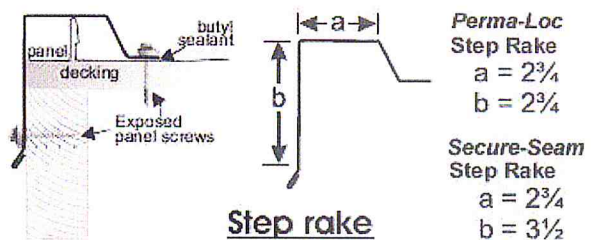

Fig. 17 Standard gable trim (EF-7) attaches to the z-flashing with rivets and to the fly rafter with either eave cleats (hidden fastener system) or exposed screws. The step rake option is shown below.

A common option in gable trim is the use of the step rake, which simplifies installation by allowing exposed screws at intervals along its length on the roof side (see diagram below).



Either type of gable trim must be fastened to the eave by either eave cleats (with hidden pancake screws) or exposed fasteners.



Custom dimensions: specify length for "a" and "b"

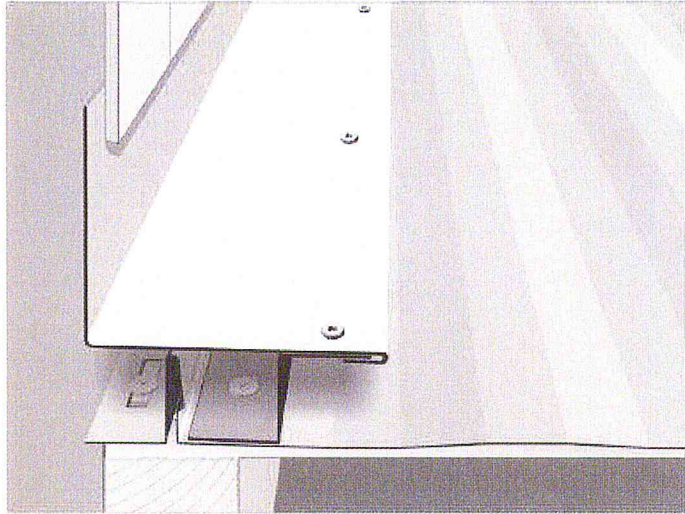
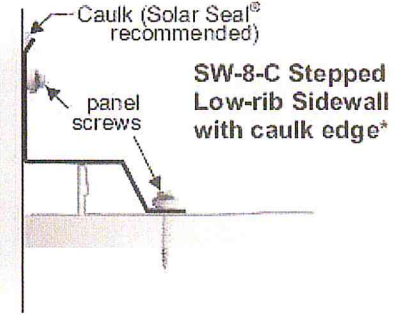
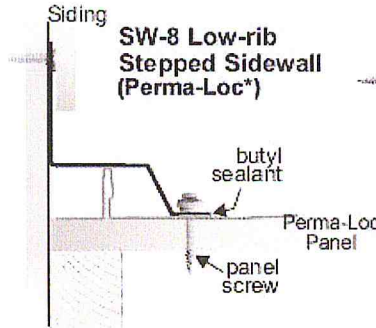
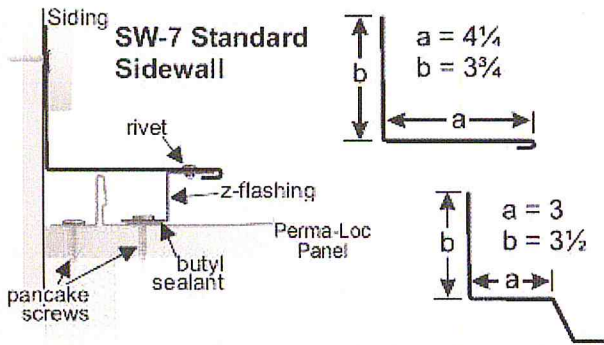

Fig. 18 Standard SW-7 Sidewall attaches to z-flashing with rivets and is covered on the wall side by siding.

Side-Wall Flashing

Sidewall installation is similar to that of gable trim. As with the EF-7 gable rake, the standard SW-7 sidewall fastens with rivets to z-flashing installed over the roof panel and, like the EF-8 step rake, the SW-8 step sidewall mounts directly to the roof with roofing screws. Either style is attached to the wall with flat fasteners like pancake screws if installed under siding (as shown in figure 17), or with panel screws (using the caulk edge SW-7-C, SW-8-C, or SW-10-C counter-flashed version) if the wall side is exposed to weather. In either case butyl tape (or equivalent) is necessary to seal under either the z-flashing or the panel side of the step rake.



For custom sidewalls, order lengths *a* and *b*

*Use SW-10 or SW-10-C stepped sidewall for Secure-Seam

End-Wall Flashing

Installation of endwalls combines Principles similar to those described for sidewalls and ridge caps. Z-flashing is either notched or cut in lengths between ribs, and attached with screws and sealant. The endwall is attached to the z-flashing with rivets, and to the wall with screws. When not covered by siding, the caulk-edge version (EW-7C) is necessary to seal the wall side of the endwall. Specify roof pitch when ordering.

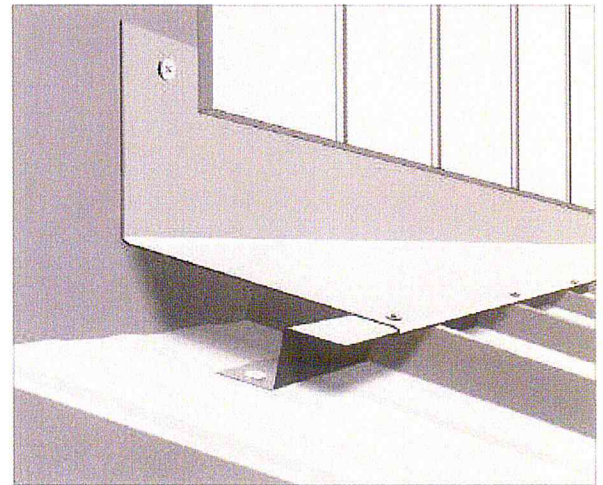
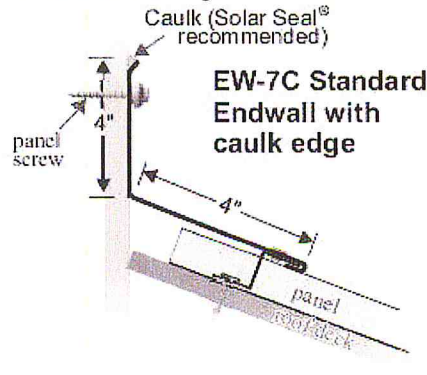
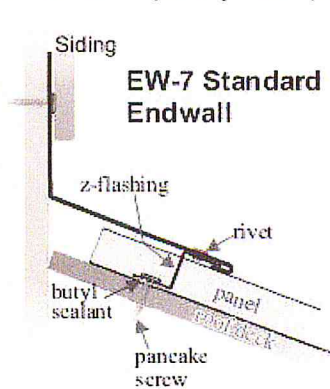
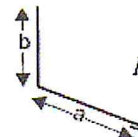

Fig. 19 Endwall flashing is applied where the upper slope of a roof meets a wall.



For custom endwalls, order lengths *a* and *b*

Preformed Valley

Panels ending in valleys must be cut and hemmed diagonally and attached to panel starter that is screwed down to the roof through the valley (see hemming diagram on p. 12). Because of the amount of water flow in the valley, care should be taken to apply butyl sealant or equivalent between the starter strip and the valley.

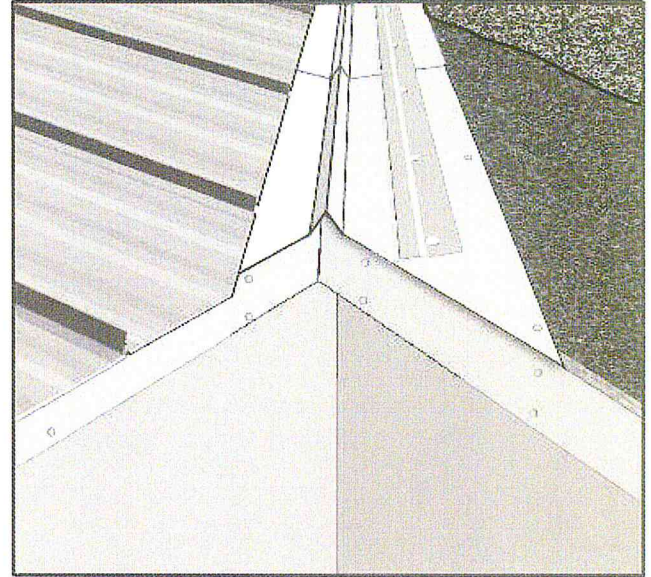

Fig. 20 Diagonally-cut panels are hemmed and attached to panel starter that is mounted on the surface of the valley.

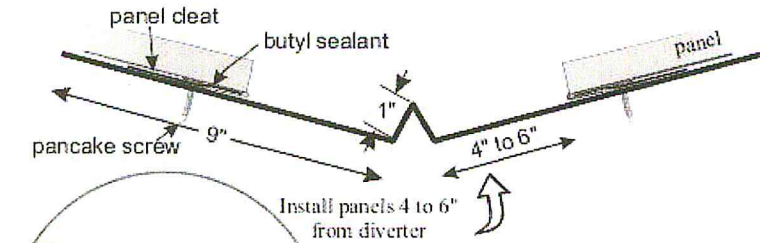

Fig. 21 Lap detail for panel cleat on transition flashing or valley.

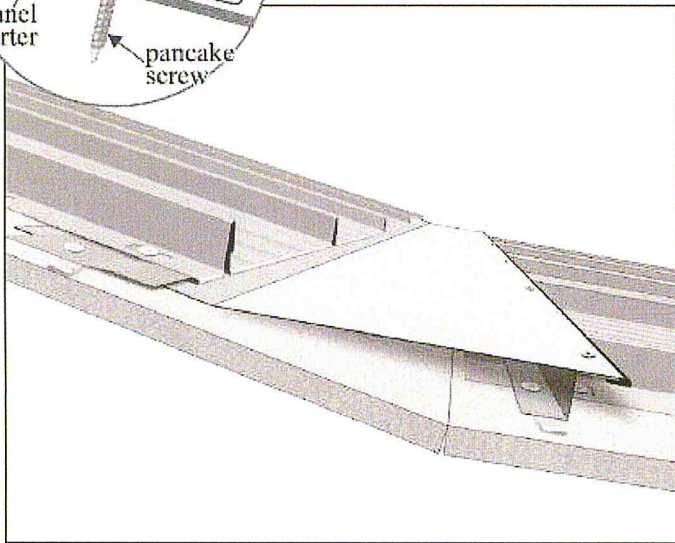
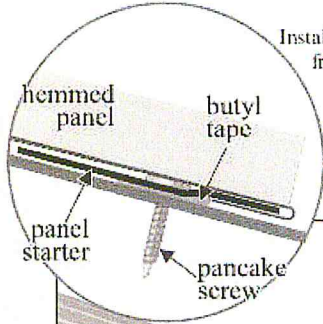

Fig. 22 Transition flashing combines the attachment techniques of valleys (top of page) with that used with ridge caps (p. 10). Notice the panel set-back that allows proper watershed from the upper panels onto the lower. The less the difference in pitch, as well as the flatter the roof, the greater the amount of set-back, and the more need for a longer "a" side on the transition flashing. The need is magnified even more for the higher-ribbed Gulf Seam panel.







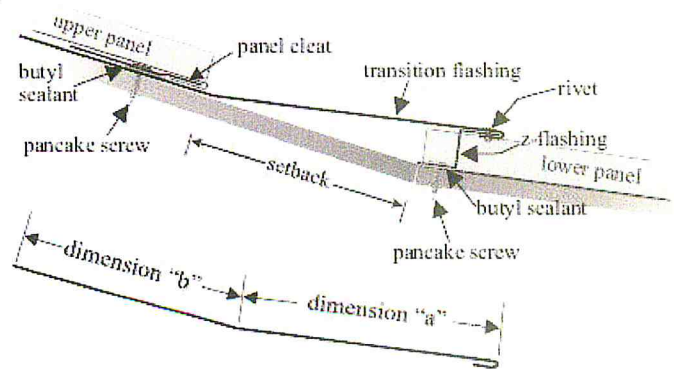

Standard dimensions: a = 6½" b = 6½"

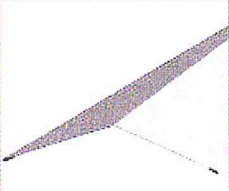
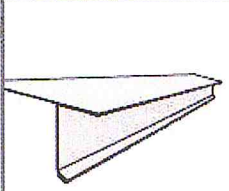
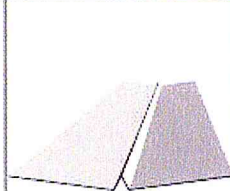
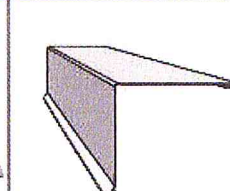
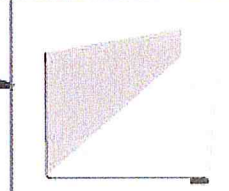
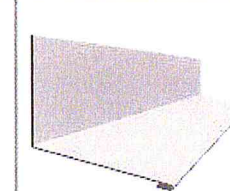
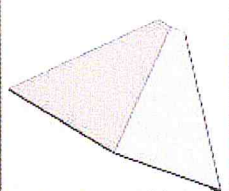
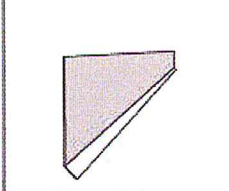
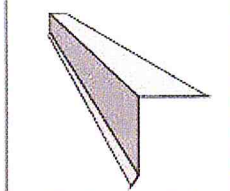
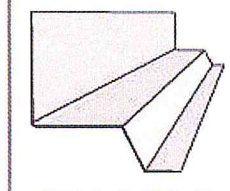
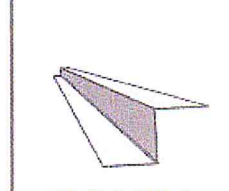
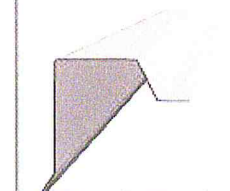
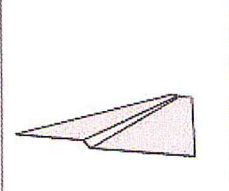
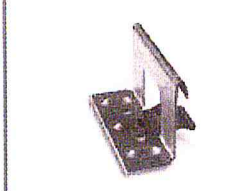
Custom dementions: specifv lenath for "a" and "b"

TF-7 Transition Flashing

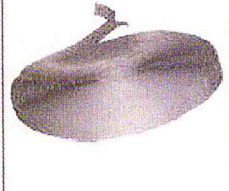
Transition flashing is required when a roof makes a change from a steeper to a lesser pitch. The panels of the upper slope are hemmed in the same fashion as they are for eave drip and attached in the same way as valleys to panel cleats. On the lower side, the transition flashing extends over the panels and is attached to z-flashing with rivets. If the lower roof is steeper than the upper section, gambrel flashing is used, mounted in the same way. Be sure to specify both upper and lower pitches when ordering.

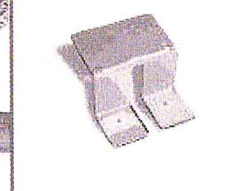
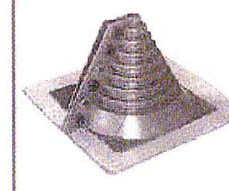

 RC-7 Ridge cap (pg. 11)	 ED-7 eave drip (pg. 8)	 PV-1 valley (pg. 8)	 EF-7 & EF-9 Gable rakes (pg. 9)	 SW-7 Sidewall (pg. 9)	 EW-7 Endwall (pg. 10)
 TF-7 Transition flashing (pg. 10)	 Eave Cleat	 ED-8 eave drip (pg. 8)	 SW-8 & SW-10 Step Sidewalls	 ZF-7 & ZF-9 Z-flashing	 EF-8 & EF-10 Step rake
 Panel Starter	 UL-90 clips	 Vent material	 Rivets	 Pancake screws	 Pipe Boots (pg. 11)
 Butyl Tape	 Solar Seal®	 Low profile Insulation	 Vent clips	 Electrical Boots	 Lifetime screws

Reed's Metals Guide to Misc. Accessories

<i>item</i>	<i>application</i>
pipe boot	Fits over vent and heat pipes. Available also in <i>heat-resistant</i> boots.
electrical boot	Fits around pipes with inaccessible tops (such as weatherheads).
UL-90 clips	Used to fasten down Secure-Seam panels. Held down with pancake screws.
Peel and Seal®	Seals hips under hip caps. Also, a general purpose sealing tape.
touch-up paint	Hides scratches and mars encountered in installation.
butyl tape	General purpose low-cost sealant, used on panel laps and under trim.
Solar Seal®	A superior general purpose caulk for all joints. Matches panel colors.
Low profile insulation	Greatly reduces radiant heat when installed under panels.
Pancake screws	Used in all applications attaching metal to wood. 1", 1½", 2½" sizes.
Stainless rivets	Self-drilling TEK screws for metal purlins. Lap TEK screws draw together joints and attach trim.
Lifetime screws	Heavy duty coated screws; available in woodgrip and self-drilling.