

**ICC Evaluation Service, Inc.**  
**www.icc-es.org**

**Business/Regional Office** ■ 5360 Workman Mill Road, Whittier, California 90601 ■ (562) 699-0543  
**Regional Office** ■ 900 Montclair Road, Suite A, Birmingham, Alabama 35213 ■ (205) 599-9800  
**Regional Office** ■ 4051 West Flossmoor Road, Country Club Hills, Illinois 60478 ■ (708) 799-2305

**DIVISION: 07—THERMAL AND MOISTURE PROTECTION****Section: 07310—Roof Shingles****Section: 07320—Roof Tiles****REPORT HOLDER:**

**DELTA BUILDING PRODUCTS LTD.**  
**9969 RIVER WAY**  
**DELTA, BRITISH COLUMBIA V4G 1M8**  
**CANADA**  
**(604) 953-1000**

**EVALUATION SUBJECT:**

**DELTA SHAKE ROOFING PANELS (STEEL AND ALUMINUM)**

**1.0 EVALUATION SCOPE****Compliance with the following codes:**

- 2003 *International Building Code*® (IBC)
- 2003 *International Residential Code*® (IRC)
- 1997 *Uniform Building Code*™ (UBC)

**Properties evaluated:**

- Roof covering fire classification
- Wind uplift resistance
- Weather resistance

**2.0 USES**

Delta Shake Panels are steel and aluminum roofing panels complying with IBC Section 1507.5, IRC Section R905.4 and UBC Section 1507.9. The panels are recognized as Class A or Class B roof coverings on new and over existing roofs, when installed in accordance with this report.

**3.0 DESCRIPTION****3.1 Roofing Panels:**

**3.1.1 Steel Roofing Panels:** The Delta Shake steel roofing panels are cold-press-formed from sheet steel complying with ASTM A 653, SS, Grade 33, and have a G90 galvanized coating. The panels are coated with a fluorocarbon paint to a minimum thickness of 1.0 mil (0.0254 mm) on the top exterior surface. The panels are painted to a minimum thickness of 0.5 mil (0.0127 mm) on the bottom surface. The total thickness of the galvanized steel is 0.0190 inch (0.483 mm), and the total G90 galvanized coating thickness is 0.0015 inch (0.038 mm). The overall panel size is 13½ inches by 50 inches (343 mm by 1270 mm), and the installed exposure is 12½ inches by 47 inches (317.5 mm by 1194 mm). The right side of each panel incorporates a 3-inch-wide (76.2 mm) side lap. The panels consist of six modules of varying widths by

12½ inches long (317.5 mm). The panels' leading front edge is bent down to form a front lip that locks into the up-facing lip formed at the top back edge of each panel. The installed weight of the steel roofing panels is approximately 1.16 psf (5.66 kg/m²). See Figure 1 for panel profile.

**3.1.2 Aluminum Roofing Panels:** The Delta Shake aluminum roofing panels are cold-press-formed from 3003-H24 aluminum alloy complying with ASTM B 209. The panels are coated with a fluorocarbon paint to a minimum thickness of 1.0 mil (0.0254 mm) on the top exterior surface. The panels are painted to a minimum thickness of 0.50 mil (0.0127 mm) on the bottom surface. The base-metal thickness of the aluminum is 0.0276 inch (0.701 mm), and the total thickness of the coated aluminum is 0.029 inch (0.737 mm). The overall panel size is 13½ inches by 50 inches (343 mm by 1270 mm), and the installed exposure is 12½ inches by 47 inches (317.5 mm by 1194 mm). The right side of each panel incorporates a 3-inch-wide (76.2 mm) side lap. The panels consist of six modules of varying widths by 12½ inches long (317.5 mm). The panels' leading front edge is bent down to form a front lip that locks into the up-facing lip formed at the top back edge of each panel. The installed weight of the Delta Shake aluminum roofing panels is approximately 0.58 psf (2.83 kg/m²). See Figure 1 for panel profile.

**3.1.3 Accessories:** Flashing components, eave starter, gable and collar trim, and ridge and hip caps are manufactured of the same steel and aluminum materials and with the same gage thicknesses and finishes as described above, except for the aluminum gable trim and ridge cap, which are manufactured from aluminum alloy 5182 Temper 0, having a minimum base thickness of 0.022 inch (0.559 mm).

**3.2 Fasteners:**

Fasteners for the steel panels shall be galvanized steel No. 10 wood screws, with a 0.190-inch (4.83 mm) outside thread diameter and a 0.135-inch (3.43 mm) inside thread diameter. The screws shall be installed with 15/32-inch-diameter (12 mm) galvanized steel washers.

As an alternative to galvanized steel screws, the fasteners for the steel panels may be galvanized steel ring-shank nails, No. 10 gage wire [0.135-inch-diameter shank (3.43 mm)] with 3/8-inch-diameter (9.5 mm) heads or No. 11 gage wire [0.120-inch-diameter shank (3.05 mm)] with 3/8-inch-diameter (9.5 mm) heads.

Fasteners for the aluminum panels shall be stainless steel No. 10 wood screws, with a 0.190-inch (4.83 mm) outside thread diameter and a 0.133-inch (3.38 mm) inside thread diameter. The screws shall be installed with 19/32-inch-diameter (15 mm) stainless steel washers.

As an alternative to the stainless steel screws, the fasteners for the aluminum panels may be aluminum ring-shank nails with 0.139-inch-diameter (3.53 mm) shanks and 1/2-inch-diameter (12.7 mm) heads.

### 3.3 Underlayment:

Underlayment shall comply with Section 1507.5.3 of the IBC or Section R905.4.3 of the IRC, as applicable. In jurisdictions enforcing the UBC, the underlayment shall consist of two layers of Type 15 or one layer of Type 30 organic fiber felt, or one or two layers of the Elk VersaShield™ underlayment recognized in ICC-ES evaluation report ER-5627. On construction permitted to be nonclassified (nonrated) roofing, underlayments may be used that are recognized in an ICC-ES evaluation report as alternatives to the ASTM D 226, Type I and Type II, underlayments specified in Chapter 15 of the IBC and Chapter 9 of the IRC; and as alternatives to the Type 15 and Type 30 underlayments specified in Chapter 15 of the UBC.

## 4.0 INSTALLATION

### 4.1 Roof Slope:

The panels shall be installed on minimum roof slopes of 3:12 (25%).

### 4.2 Installation—New Construction:

The panels shall be installed on solid plywood sheathing or spaced sheathing complying with the applicable code. Underlayment, as described in Section 3.3 of this report, shall be applied per the applicable code. Roofing assemblies incorporating Elk VersaShield™ underlayment, used to satisfy Class A or Class B roof classification requirements, shall be installed in accordance with ICC-ES evaluation report ER-5627. Full roof panels shall be placed over the underlayment and shall start at the eave. The front of the panels in the first course shall be hooked into the lip of the eave starter flashing. The panels overlap on the right side of each panel by 3 inches (76.2 mm). The rear of each panel shall be fastened to the sheathing with clips and fasteners as described in Table 1. The clips shall be equally spaced along the panel. The fasteners shall be as specified in Section 3.2 and shall be of sufficient length to penetrate through the sheathing a minimum of 1/2 inch (12.7 mm). The front of each panel shall be attached to the rear of the panel beneath by inserting and locking the front lip into the rear lip on the lower panel. At valleys, additional fastening details apply, as shown in Figure 2.

Panels shall be cut and formed at valleys, leaving a closed valley. As an alternative, a Delta Building Products Ltd.–supplied valley flashing, as illustrated in Figure 2, may be installed and the panels may be cut and slotted into either side of the open valley flashing.

Valley flashings shall comply with Section 1507.5.6 of the IBC, Section R905.4.6 of the IRC, or Section 1508.3 of the UBC. Other flashing shall comply with Section 1503.2.1 of the IBC, Section R903.2.1 of the IRC, or Section 1509 of the UBC.

Penetrations through the roof covering shall be flashed by installing standard roof jacks which drain over the panel immediately below the penetration. The lower edge of the panel containing the jack shall be notch-cut-out to allow water drainage from the jack to the top of the panel below.

### 4.3 Installation—Reroofing:

The existing roof covering shall be completely removed and the panels installed in accordance with Section 4.2 of this report, except over asphalt shingle roofs as described in this section. The panels may be installed over existing spaced sheathing provided the space between boards is filled with lumber as necessary to provide a base for fastening. The fill lumber shall be of the same thickness as the existing spaced sheathing. The Delta Shake roofing panels may be installed over existing asphalt shingle roofs, provided the roof slope

complies with Section 4.1 of this report and the requirements of IBC Section 1510, IRC Section R907, or UBC Appendix Section 1518 are met. The panels shall be fastened through the existing roof covering to the roof sheathing in the same manner as described in Section 4.2, with screws or nails of sufficient length to penetrate through the sheathing a minimum of 1/2 inch (12.7 mm). New flashing shall be installed over and around all existing flashing, vents, valleys and chimneys in accordance with this report and the applicable code. Raised perimeters shall be covered by the Delta Shake panel roofing system.

Roofing assemblies incorporating Elk VersaShield™ underlayment, used to satisfy the Class A or Class B roof classification requirements, shall be installed in accordance with ICC-ES evaluation report ER-5627.

### 4.4 Fire Classification:

Delta Shake steel roofing panels installed in accordance with Section 4.2 or 4.3 of this report are recognized as Class A roof assemblies under IBC Section 1505.2 and IRC Section R902.1.

Delta Shake aluminum roofing panels installed in accordance with Section 4.2 or 4.3 are recognized as Class B roof assemblies under IBC Section 1505.3, and as Class A roof assemblies under IRC Section R902.1.

Delta Shake steel roofing panels installed in accordance with Section 4.2 or 4.3 are recognized as noncombustible roof coverings in accordance with Section 1504.2 of the UBC. Noncombustible roof coverings as defined in Section 1504.2 of the UBC are permitted in Section 1503 of the UBC to be applied in lieu of a Class A fire-retardant roofing assembly when the installation is in accordance with the manufacturer's requirements and this report.

Delta Shake aluminum roofing panels installed in accordance with Section 4.2 or 4.3 of this report are recognized as nonrated roofing in accordance with Section 1504.3 of the UBC except that roofing assemblies incorporating Elk VersaShield™ underlayment installed in accordance with ICC-ES evaluation report ER-5627 are Class A or Class B fire-retardant roofing assemblies.

### 4.5 Wind Resistance:

Delta Shake steel and aluminum roofing panels installed in accordance with Section 4.0, using the fasteners and clips specified in Table 1, over 15/32-inch-thick (11.9 mm) plywood, are acceptable for the maximum allowable uplift loads specified in Table 1. The design wind pressure shall be determined in accordance with IBC Section 1609.6 and IBC Tables 1609.6.2.1(2), (3) and (4); IRC Section R301.2.1; and UBC Section 1620.

Positive (gravity) loads shall be limited to the adequacy of the supporting structural framing and sheathing.

### 4.6 Severe Climate Areas:

In jurisdictions enforcing the IBC or IRC, an ice barrier shall be provided in accordance with IBC Section 1507.5.3 or IRC Section R905.4.3.

In jurisdictions enforcing the UBC, in areas subject to wind-driven snow, ice build-up, or wind-driven dust or sand, or in other areas designated by the code official, both of the following shall be provided:

- Solid sheathing with two layers of Type 15 felt or one layer of Type 30 felt for the field of the roof.
- Solid sheathing with two layers of Type 15 underlayment cemented together with approved cementing material between the plies, or a self-adhering polymer modified bitumen sheet recognized in a current ICC-ES evaluation

report, used in lieu of standard underlayment around the perimeter of the roof and extending from the roof edge to a point at least 36 inches (914 mm) inside the exterior wall line of the building. Use of the bitumen sheet shall be limited to new construction, and reroofing shall be limited to nonrated construction.

### 5.0 CONDITIONS OF USE

The Delta Shake Roofing Panels described in this report comply with, or are suitable alternatives to what is specified in, those codes listed in Section 1.0 of this report, subject to the panels' being manufactured, identified and installed in accordance with this report and the manufacturer's published installation instructions.

### 6.0 EVIDENCE SUBMITTED

Data in accordance with the ICC-ES Acceptance Criteria for Metal Roof Coverings (AC166), dated November 2001 (editorially revised November 2004).

### 7.0 IDENTIFICATION

A label bearing the manufacturer's name (Delta Building Products Ltd.) and address, the product name and the ICC-ES evaluation report number (ESR-1790) shall be affixed to each pallet or bundle.

TABLE 1—ALLOWABLE UPLIFT LOAD CONDITIONS

PANEL TYPE	FASTENER TYPE <sup>1</sup>	NUMBER OF CLIPS PER PANEL	NUMBER OF FASTENERS PER CLIP	ALLOWABLE UPLIFT LOADS, psf (kPa)
Aluminum	Stainless steel No. 10 wood screw	3	1	45 (2.15)
Aluminum	Stainless steel No. 10 wood screw	2	1	32.5 (1.56)
Aluminum	Stainless steel No. 10 wood screw	4	2	115 (5.51)
Aluminum	Aluminum ring shank nail	4	1	37.5 (1.80)
Aluminum	Aluminum ring shank nail	4	2	80 (3.83)
Steel	Galvanized steel No. 10 wood screw	3	1	45 (2.15)
Steel	Galvanized steel No. 10 wood screw	2	1	32.5 (1.56)
Steel	Galvanized steel No. 10 wood screw	4	2	115 (5.51)
Steel	Galvanized steel No. 10 gage ring shank nail	4	1	37.5 (1.80)
Steel	Galvanized steel No. 10 gage ring shank nail	4	2	80 (3.83)
Steel	Galvanized steel No. 11 gage ring shank nail	3	2	37.5 (1.80)
Steel	Galvanized steel No. 11 gage ring shank nail	6	2	80 (3.83)

For SI: 1 psf = 0.04788 kPa.

<sup>1</sup>Fasteners shall be as specified in Section 3.2 of this report. For reroofing, the length of the fasteners shall be increased to allow a minimum of 1/2 inch (12.7 mm) of penetration through the sheathing.

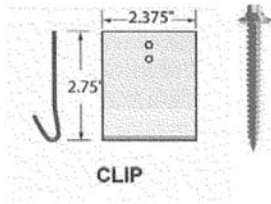

CLIP

### Delta Shake Installation with Screws (Basic Wind Configuration)

See Section 3.2 for description of screws

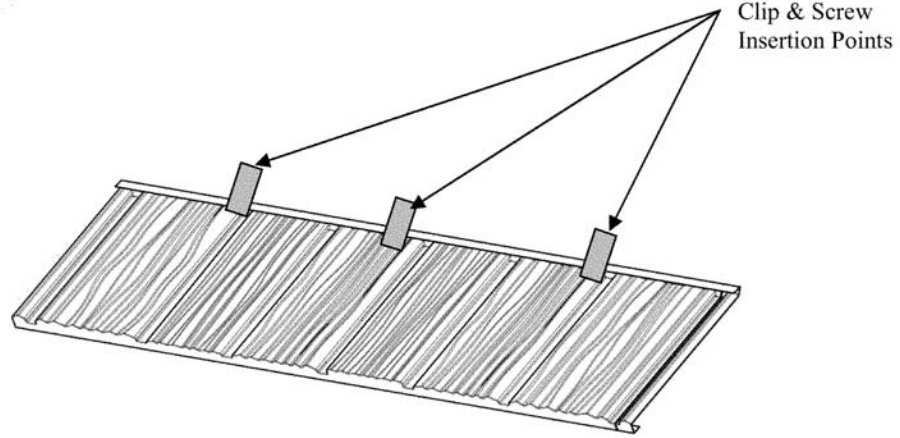

Clip & Screw  
Insertion Points

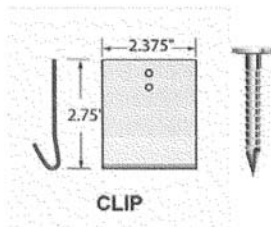

CLIP

### Delta Shake Installation with Nails (Basic Wind Configuration)

See Section 3.2 for description of ring shank nails

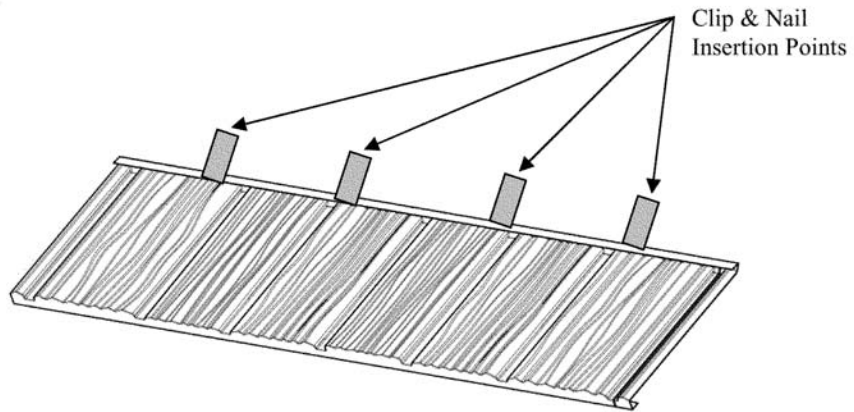

Clip & Nail  
Insertion Points

FIGURE 1

*Valley Trim Installation*

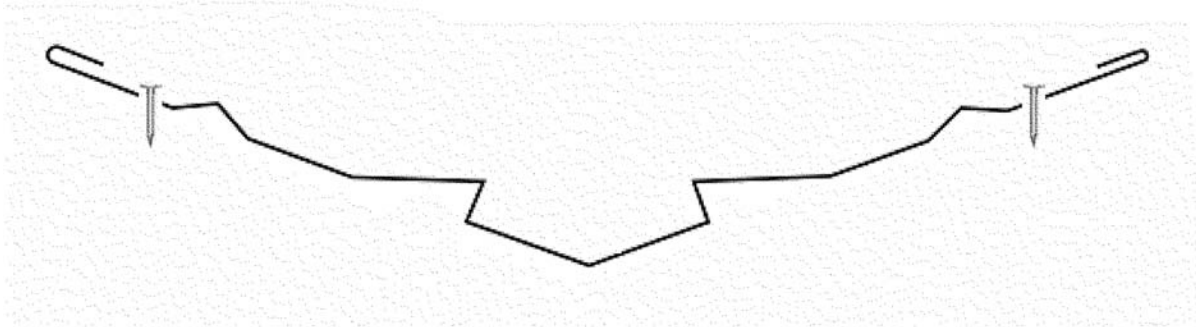

**VALLEY INSTALLATION**

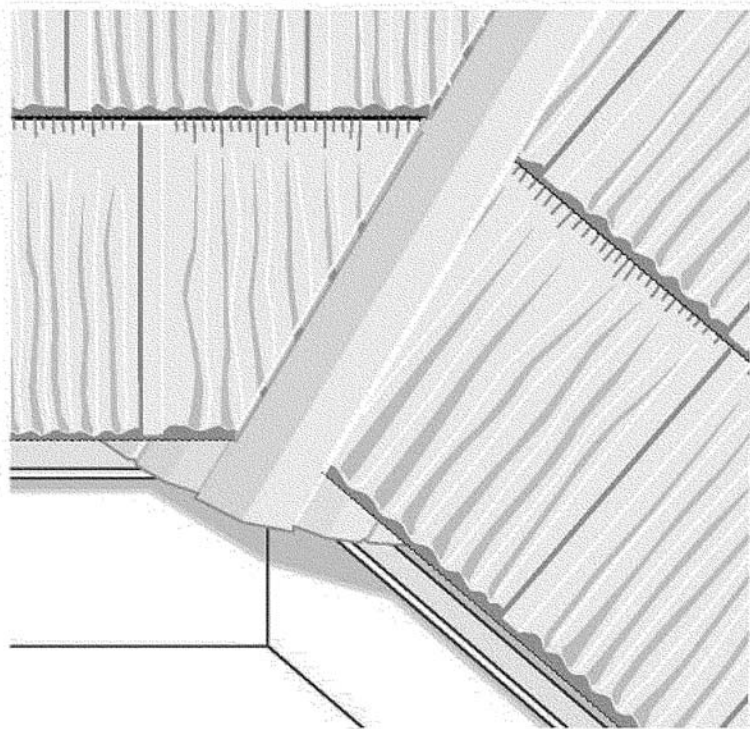

**FIGURE 2**