



ICC
EVALUATION
SERVICE

In Cooperation with



Most Widely Accepted and Trusted

ESR-2605

Reissued 07/2018

Revised 01/2019

This report is subject to renewal 07/2019.

ICC-ES Evaluation Report

ICC-ES | (800) 423-6587 | (562) 699-0543 | www.icc-es.org

DIVISION: 06 00 00—WOOD, PLASTICS AND COMPOSITES
SECTION: 06 05 23—WOOD, PLASTIC, AND COMPOSITE FASTENINGS

REPORT HOLDER:

SIMPSON STRONG-TIE COMPANY INC.

EVALUATION SUBJECT:

**SIMPSON STRONG-TIE® CONNECTORS FOR METAL PLATE CONNECTED WOOD
TRUSS CONSTRUCTION**



“2014 Recipient of Prestigious Western States Seismic Policy Council (WSSPC) Award in Excellence”



ICC-ES Evaluation Reports are not to be construed as representing aesthetics or any other attributes not specifically addressed, nor are they to be construed as an endorsement of the subject of the report or a recommendation for its use. There is no warranty by ICC Evaluation Service, LLC, express or implied, as to any finding or other matter in this report, or as to any product covered by the report.



Copyright © 2019 ICC Evaluation Service, LLC. All rights reserved.

ICC-ES Evaluation Report

ESR-2605

Reissued July 2018

Revised January 2019

This report is subject to renewal July 2019.

www.icc-es.org | (800) 423-6587 | (562) 699-0543

A Subsidiary of the International Code Council®

DIVISION: 06 00 00—WOOD, PLASTICS AND COMPOSITES

Section: 06 05 23—Wood, Plastic, and Composite Fastenings

REPORT HOLDER:

SIMPSON STRONG-TIE COMPANY INC.

EVALUATION SUBJECT:

SIMPSON STRONG-TIE® CONNECTORS FOR METAL PLATE CONNECTED WOOD TRUSS CONSTRUCTION

1.0 EVALUATION SCOPE

Compliance with the following codes:

- 2018, 2015, 2012, 2009 and 2006 *International Building Code*® (IBC)
- 2018, 2015, 2012, 2009 and 2006 *International Residential Code*® (IRC)

Property evaluated:

Structural

2.0 USES

Simpson Strong-Tie® connectors for metal plate connected wood truss construction are used as wood framing connectors in accordance with 2018 and 2015 IBC Sections 2303.4 and 2304.10.3 and 2012, 2009 and 2006 IBC Sections [2303.4](#) and [2304.9.3](#). The products may also be used in structures regulated under the IRC when an engineered design is submitted in accordance with Sections [R301.1.3](#), [R502.11](#), and [R802.10](#) of the IRC.

3.0 DESCRIPTION

3.1 General:

The connectors described in this report connect wood framing members in metal plate connected wood truss floor or roof construction.

3.1.1 GBC Gable Brace Connectors: The GBC connects wood framed wall top plates to wood roof members to transfer out-of-plane loads on gable end walls. The product is formed from No. 16 gage galvanized steel. See [Table 1](#) for required fasteners and allowable lateral loads perpendicular to the wall plate. See [Figure 1](#) for drawings of the GBC connector showing product dimensions and typical installations.

3.1.2 TSBR Truss Spacer Restraint: The TSBR connectors are used as permanent truss lateral restraint

that provides lateral support to trusses when installed at right angles to the plane of the truss members. The TSBR is formed from No. 22 gage galvanized steel. See [Table 2](#) for the model number, required fasteners, TSBR connector length, and allowable tension and compression loads. See [Figure 2](#) for drawings of the TSBR truss spacer restraint and a typical installation.

3.1.3 VTCR Single-Sided Valley Truss Clip: The VTCR clip provides a connection between the valley truss and the supporting framing below. It is installed over flat or sloped wood-based structural-use roof sheathing and fastened through the sheathing into the supporting framing below. The VTCR clip is formed from No. 18 gage galvanized steel. See [Table 3](#) for the product model number dimensions, required fasteners and allowable loads. See [Figure 3](#) for drawings of the VTCR clip showing overall dimensions, and typical installation details.

3.1.4 TC Truss Clip: The TC truss clip connects wood trusses to wood top plates of wood framed walls. The TC truss clips have horizontal slotted nail holes to allow for horizontal movement between the two members. The TC truss clip is formed from No. 16 gage galvanized steel. See [Table 4](#) for model numbers, required fasteners, and allowable loads. See [Figure 4](#) for drawings of the TC truss clips and typical installation details.

3.1.5 TBE Truss Bearing Enhancer: The TBE truss bearing enhancer transfers gravity loads from the truss to wood-framed wall double top plate and provides uplift capacity. The product is formed from No. 18 gage galvanized steel. See [Table 5](#) for the model numbers, required fasteners, and allowable loads. See [Figure 5](#) for drawings of the TBE4 connector showing overall dimensions and a typical installation detail.

3.1.6 LTHJA26 and THJA26 Hangers: The LTHJA26 hanger is formed from No. 18 gage galvanized steel, and the THJA26 hanger is formed from No. 14 gage galvanized steel. See [Table 6](#) for required fasteners and allowable loads for hangers supporting hip and jack truss combinations or two hip trusses, and [Figure 6](#) for a drawing showing the dimensions of the LTHJA26 and THJA26 hangers.

3.1.7 LTHMA Hanger: The LTHMA hanger is formed from No. 16 gage galvanized steel. The hanger has three U-shaped stirrups that may be field-adjusted to a maximum 45-degree slope from the horizontal. See [Table 7](#) for required fasteners and allowable loads for carried hip and jack trusses, and [Figure 7](#) for a drawing showing the dimensions of the LTHMA hanger.

3.1.8 THJM2-4 and THJM2-5 Hangers: The THJM2-4

and THJM2-5 hangers are designed to carry four or five radial members, respectively, into a supporting girder. The THJM2 hangers are fastened to the members with Simpson Strong-Tie SDS Strong-Drive Screws, which are supplied with the connectors. The THJM2-4 and THJM2-5 hangers are formed from No. 12 gage galvanized steel. See [Table 8](#) for required fasteners and allowable loads. See [Figure 8](#) for drawings of the THJM2-4 and THJM2-5 hangers showing overall dimensions and typical installation details.

3.1.9 THJU26 and THJU26-W Hangers: The THJU26 and THJU26-W hangers are formed from No. 12 gage galvanized steel. See [Table 9](#) for required fasteners and allowable loads for hangers supporting hip and jack truss combinations. See [Figure 9](#) for drawings of the THJU26 and THJU26-W hangers showing overall dimensions and typical installation details.

3.1.10 DSC2 and DSC5 Drag Strut Connectors: The DSC2 and DSC5 connectors transfer diaphragm shear forces from drag struts, such as drag trusses, to the shear walls. The connectors are available in left hand and right hand versions, designated with an L or R, respectively, in the model number (e.g., DSC2L-SDS3). The DSC connectors are fastened to the drag strut and wood top plate with Simpson Strong-Tie SDS Strong-Drive Screws, which are supplied with the connectors. The DSC2 is formed from No. 7 gage galvanized steel, and the DSC5 is formed from No. 3 gage steel. See [Table 10](#) for model numbers and the required fasteners and allowable loads. See [Figure 10](#) for drawings of the DSC2 and DSC5 showing overall dimensions and typical installation details.

3.1.11 AHEP Adjustable Hip-end Purlin: The AHEP connectors are used as structural purlins for hip-end systems to transfer loads from the roof sheathing to the primary framing members. The AHEP has an adjustable length to accommodate varying hip-end pitches, and is load-rated for pitches from 3-in-12 to 9-in-12. The AHEP is installed on the flat top chords of step-down hip trusses, and then the roof sheathing is installed over the AHEP and attached directly to it. The AHEP is formed from No. 20 gage galvanized steel. See [Table 11](#) for required fasteners and allowable loads. See [Figure 11](#) for a drawing of the AHEP and a typical installation detail.

3.2 Materials:

3.2.1 Steel: The connectors described in this report, with the exception of the DSC5, are manufactured from galvanized sheet steel complying with [ASTM A653](#), SS designation, Grade 33, with a minimum yield strength, F_y , of 33,000 psi (227 MPa) and a minimum tensile strength, F_u , of 45,000 psi (310 MPa). The DSC5 is manufactured from ASTM A1011 Grade 33, with a minimum yield strength, F_y , of 33,000 psi (227 MPa) and a minimum tensile strength, F_u , of 55,000 psi (358 MPa). Base-metal thicknesses for the connectors in this report are as follows:

NOMINAL THICKNESS (Gage)	MINIMUM BASE-METAL THICKNESS (inch)
No. 3	0.2285
No. 7	0.1715
No. 12	0.0975
No. 14	0.0685
No. 16	0.0555
No. 18	0.0445
No. 20	0.0350
No. 22	0.0275

For SI: 1 inch = 25.4 mm.

The galvanized zinc coating conforms to ASTM A653 with a G90 designation. Some models (designated with a model number ending with Z) are available with a G185 zinc coating specification in accordance with ASTM A653. Some models (designated with a model number ending with HDG) are available with a hot-dip galvanization, also known as “batch” galvanization, in accordance with [ASTM A123](#), with a minimum specified coating weight of 2.0 ounces of zinc per square foot of surface area (610 g/m²), total for both sides. Model numbers in this report do not include the Z or HDG ending, but the information shown applies. The lumber treater and the holder of this report (Simpson Strong-Tie Company) should be contacted for recommendations on the appropriate coating or material to specify for use of the steel connectors in contact with the specific proprietary preservative-treated or fire-retardant-treated lumber.

3.2.2 Wood: Wood members with which the connectors are used must be either sawn lumber or engineered lumber having a minimum specific gravity of 0.50 (minimum equivalent specific gravity of 0.50 for engineered lumber), and having a maximum moisture content of 19 percent (16 percent for engineered lumber), except as noted in Section 4.1. Unless otherwise noted, the thickness of the supporting wood main member must be equal to or greater than the length of the fasteners specified in the tables of this report, or as required by wood member design, whichever is greater. For installation in engineered wood members, minimum allowable nail spacing and end and edge distances, as specified in the applicable evaluation report for the engineered wood product, must be met.

3.2.3 Fasteners: Nails used with connectors described in this report must be bright or hot-dipped galvanized carbon steel nails complying with the material requirements, physical properties, tolerances, workmanship, protective coating and finishes, certification, and packaging and package marking requirements specified in [ASTM F1667](#). The nails must have the following minimum fastener dimensions and bending yield strengths (F_{yb}):

FASTENER	SHANK DIAMETER (inch)	FASTENER LENGTH (inches)	F_{yb} (psi)
8d x 1 1/2	0.131	1 1/2	100,000
8d	0.131	2 1/2	100,000
10d x 1 1/2	0.148	1 1/2	90,000
10d	0.148	3	90,000
16d	0.162	3 1/2	90,000

For SI: 1 inch = 25.4 mm, 1 psi = 6.895 kPa.

Alternatively, nails of other materials or finishes may be used when they are recognized in an ICC-ES evaluation report as having bending yield strength and withdrawal capacity to or better than those of a bright carbon steel of the same nominal diameter.

Some of the connectors described in this report are attached to the wood members using Simpson Strong-Tie Strong-Drive SDS series wood screws as described in [ESR-2236](#), or Simpson Strong-Tie Strong-Drive SD series wood screws as described in [ESR-3046](#).

Fasteners used in contact with preservative-treated or fire-retardant-treated lumber must comply with IBC Section 2304.10.5; 2012, 2009 and 2006 IBC Section [2304.9.5](#); 2018, 2015, 2012 and 2009 IRC Section [R317.3](#); or 2006 IRC Section [R319.3](#), as applicable. For use with treated lumber, the lumber treater or this report holder (Simpson Strong-Tie Company), or both, should be contacted for

recommendations on the appropriate coating or material to specify for the fasteners as well as the connection capacities of fasteners used with the specific proprietary preservative-treated or fire-retardant-treated lumber.

4.0 DESIGN AND INSTALLATION

4.1 Design:

The tabulated allowable loads shown in the product tables of this report are based on Allowable Stress Design (ASD) and include the load duration factor, C_D , corresponding with the applicable loads in accordance with the National Design Specification for Wood Construction and its supplement (NDS).

Tabulated allowable loads apply to products connected to wood used under dry conditions and where sustained temperatures are 100°F (37.8°C) or less. When products are installed in wood having a moisture content greater than 19 percent (16 percent for engineered wood products), or where wet service is expected, the allowable loads must be adjusted by the wet service factor, C_M , specified in the NDS for dowel-type fasteners. When connectors are installed in wood that will experience sustained exposure to temperatures exceeding 100°F (37.8°C), the allowable loads in this report must be adjusted by the applicable temperature factor, C_t , specified in the NDS. Connected wood members must be analyzed for load-carrying capacity at the connection in accordance with the NDS.

4.2 Installation:

Installation of the connectors must be in accordance with this evaluation report and the manufacturer's published installation instructions. Bolts and nails must be installed in accordance with the applicable provisions in the NDS. In the event of a conflict between this report and the manufacturer's published installation instructions, this report governs.

5.0 CONDITIONS OF USE

The Simpson Strong-Tie connectors described in this report comply with, or are suitable alternatives to what is specified in, those codes listed in Section 1.0 of this report, subject to the following conditions:

- 5.1 The connectors must be manufactured, identified and installed in accordance with this report and the manufacturer's published installation instructions. A copy of the instructions must be available at the jobsite at all times during installation.
- 5.2 Calculations showing compliance with this report must be submitted to the code official. The calculations must be prepared by a registered design professional

where required by the statutes of the jurisdiction in which the project is to be constructed

- 5.3 Adjustment factors noted in Section 4.1 and the applicable codes must be considered, where applicable.
- 5.4 Connected wood members and fasteners must comply, respectively, with Sections 3.2.2 and 3.2.3 of this report.
- 5.5 Use of connectors with preservative-treated or fire-retardant-treated lumber must be in accordance with Section 3.2.1 of this report. Use of fasteners with preservative-treated or fire-retardant-treated lumber must be in accordance with Section 3.2.3 of this report.

6.0 EVIDENCE SUBMITTED

Data in accordance with the ICC-ES Acceptance Criteria for Joist Hangers and Similar Devices (AC13), dated March 2018.

7.0 IDENTIFICATION

- 7.1 The products described in this report are identified with a die-stamped label or an adhesive label indicating the name of the manufacturer (Simpson Strong-Tie), the model number, and the number of an index evaluation report ([ESR-2523](#)) that is used as an identifier for the products recognized in this report.
- 7.2 The report holder's contact information is the following:

SIMPSON STRONG-TIE COMPANY INC.
5956 WEST LAS POSITAS BOULEVARD
PLEASANTON, CALIFORNIA 94588
(800) 925-5099
www.strongtie.com

TABLE 1—GBC GABLE BRACE CONNECTOR

MODEL NO.	FASTENERS PER CONNECTOR ¹ (Quantity-Type)		ALLOWABLE LOADS (F ₂) PERPENDICULAR TO WALL TOP PLATE ^{2,3} (lbs) C _D = 1.6			
			Allowable Tension (F ₂ Away) for Gable Brace Installed at a Slope between:		Allowable Compression (F ₂ Toward) for Gable Brace Installed at a Slope between:	
	Brace Member ⁴	Top Plates	40°– 45°	46° – 60°	40°– 45°	46° – 60°
GBC	5 – 8d x 1 ¹ / ₂	7 – 8d	390 ⁽⁵⁾	300	650 ⁽⁵⁾	825

For SI: 1 inch = 25.4 mm, 1 lbs = 4.45 N.

¹Nails used with the GBC connector and LVL products (see footnote 5) must also comply with the minimum edge and spacing limitations specified in the evaluation report for the specific LVL product.

²Allowable loads have been increased for wind or earthquake loading with no further increases allowed. Allowable loads must be reduced when other load durations govern.

³Allowable loads shown are for one pair of connectors. The GBC connectors must be installed in pairs, as shown in Figure 1.

⁴Minimum brace member size must be nominal 2x4 lumber having a minimum specific gravity of 0.50 or LVL having an equivalent minimum specific gravity of 0.50 (see footnote 5).

⁵Brace members consisting of minimum 1³/₄" x 3¹/₂" LVL, the allowable loads at 40 to 45 degrees are 515 lbs tension (F₂ Away) and 635 lbs compression (F₂ Toward).

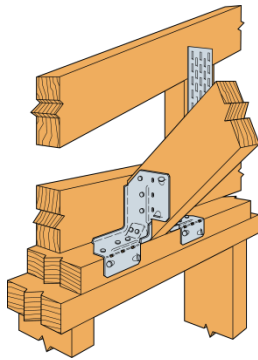

GBC Typical Installation

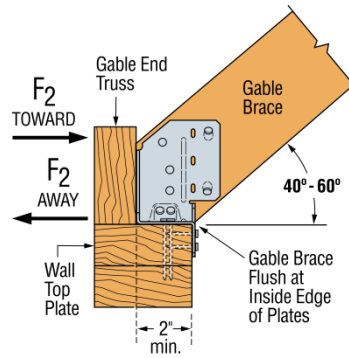

GBC Installation Detail and Allowable Load Directions
F₂ (toward) and F₂ (away)

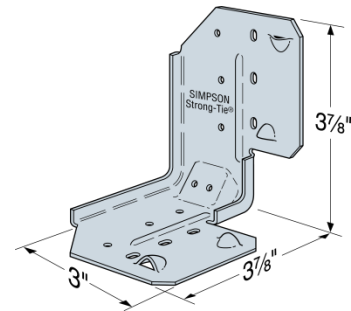

GBC Gable Brace Connector Dimensions
U.S. Patent
7,788,873;
5,603,580

FIGURE 1—GBC GABLE BRACE CONNECTOR

TABLE 2—TSBR TRUSS SPACER-RESTRAINT^{1,2}

MODEL NO.	FASTENERS (Total Quantity - Type)	DIMENSIONS (inches)			ALLOWABLE LOADS ³ (lbs) C _D = 1.6	
		Length (L)	Width (W)	Depth (D)	Compression	Tension
TSBR2-24 (Min) ⁴	2-10d	25 ¹ / ₂	1 ³ / ₄	1	500	180
TSBR2-24 (Max) ⁵	4-10dx1 ¹ / ₂				500	465

For SI: 1 inch = 25.4 mm, 1 pound = 4.45 N.

¹The TSBR connectors are used as a permanent truss lateral restraint that provides lateral support to trusses when installed at right angles to the plane of the truss member. The design of the TSBR connectors must comply with Section 2303.4.1.2 of the IBC.

²TSBR connectors must be free of deformations such as dents, bends, or other defects that will adversely affect the performance of the connector in compression.

³Allowable loads have been increased for wind or earthquake loading with no further increases allowed. Allowable loads must be reduced when other load durations govern.

⁴The suffix (Min) corresponds to a minimum nailing condition in which the nails specified in the table are installed into the round holes in the TSBR connectors.

⁵The suffix (Max) corresponds to a maximum nailing condition in which all the pre-punched nail holes (round and triangle) in the TSBR connectors are filled with the nails specified in the table.

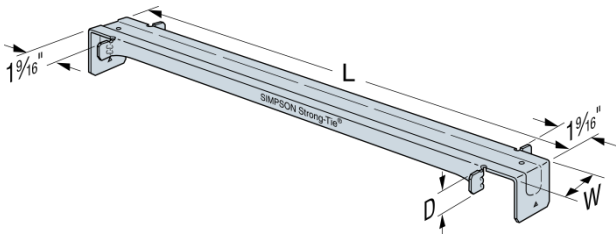

TSBR Truss Spacer-Restraint
U.S. Patent 6,993,882

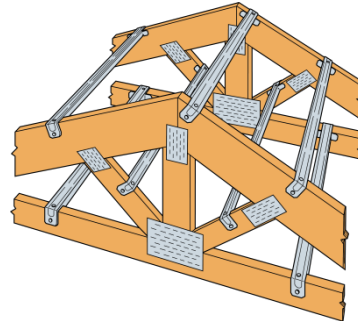

TSBR Installation on Nominally 2-inch-wide Wood Trusses

FIGURE 2—TSBR TRUSS SPACER-RESTRAINT

TABLE 3—VTCR SINGLE-SIDED VALLEY TRUSS CLIP

MODEL NO.	FASTENERS (Quantity - Type)		SUPPORTING ROOF PITCH	ALLOWABLE LOADS ¹ (lbs)	
	Supporting Framing	Valley Truss		Uplift ² (C _D = 1.6)	Download ³ C _D = 1.0 C _D = 1.15 C _D = 1.25
VTCR	4-10d	3-10dx1 ¹ / ₂ "	< 5:12	325	790
			5:12 to 12:12	325	790
	4-SD#9x2 ¹ / ₂ "	3-SD#9x1 ¹ / ₂ "	< 5:12	340	790
			5:12 to 12:12	415	790

For SI: 1 inch = 25.4 mm, 1 pound = 4.45 N.

¹Tabulated allowable loads are applicable to installation over roof sheathing having a nominal thickness of 7/16 inch or 15/32 inch.

²The uplift load capacities have been increased for wind or earthquake loading with no further increases allowed. Allowable loads must be reduced when other load durations govern.

³The download capacities may not be increased.

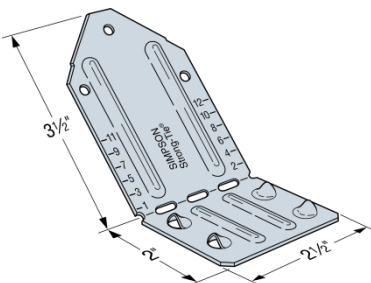

VTCR Single-Sided Valley Truss Clip
U.S. Patent
D640,916

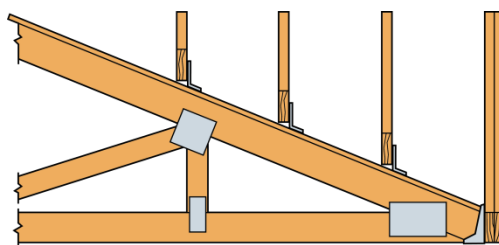

Typical VTCR Installation Side View

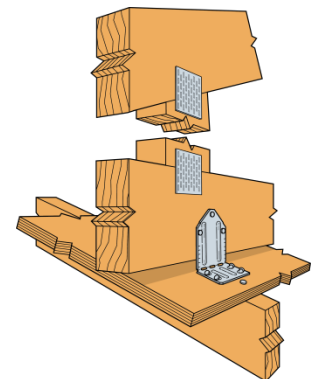

Typical VTCR Installation

FIGURE 3—VTCR SINGLE-SIDED VALLEY TRUSS CLIP

TABLE 4—TC TRUSS CLIP

MODEL NO.	FASTENERS (Quantity - Type)		ALLOWABLE UPLIFT LOADS ¹ (lbs) C _D = 1.6
	Truss ²	Plate	
TC24	4-10d	4-10d	310
TC26	5-10d	6-10d	575
TC28	5-10d	6-10d	575

For SI: 1 inch = 25.4 mm, 1 pound = 4.45 N.

¹The load capacities have been increased for wind or earthquake loading with no further increases allowed. Allowable loads must be reduced when other load durations govern.

²Truss nails must be driven into the truss at the inside end of the slotted holes (towards the center of the truss) and clinched on the opposite side of the truss.

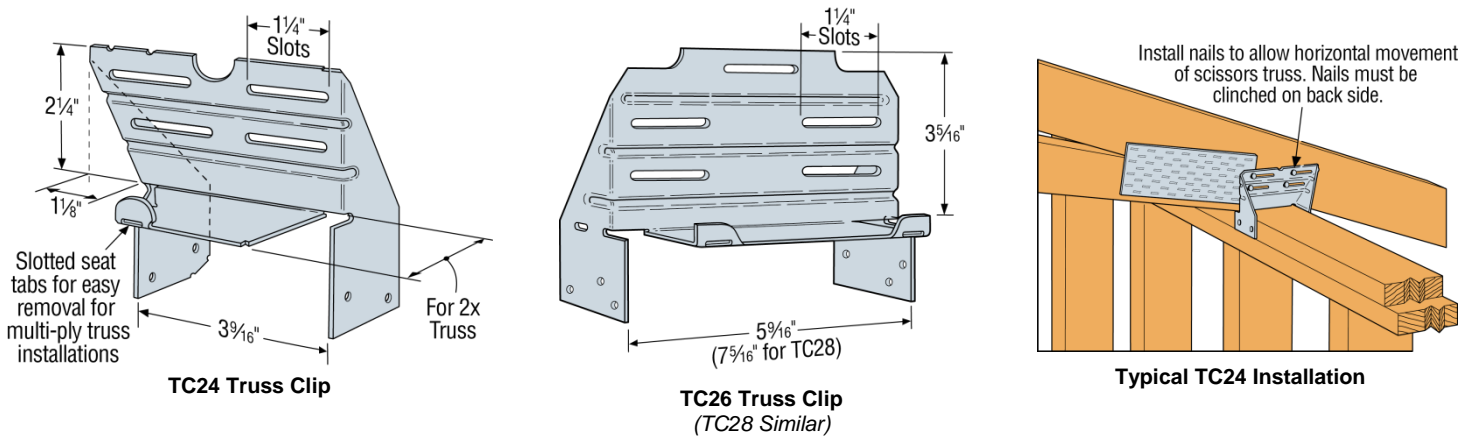

FIGURE 4—TC TRUSS CLIP

TABLE 5—TBE TRUSS BEARING ENHANCER

MODEL NO.	TRUSS PLIES ¹	FASTENERS (Quantity - Type)		ALLOWABLE LOADS ^{2,3} (lbs) C _D = 1.6		
		Rafter	Plate	Uplift	Lateral	
					Parallel-to-Plate (F1)	Perpendicular-to-Plate (F2)
TBE4	1	10 - 10d x 1 1/2	10 - 10d x 1 1/2	690	370	810
	2	10 - 10d	10 - 10d			
	3	10 - 10d	10 - 10d			
	4	10 - 10d	10 - 10d			
TBE6	1	10 - 10d x 1 1/2	10 - 10d x 1 1/2	880	255	860
	2	10 - 10d	10 - 10d			
	3	10 - 10d	10 - 10d			
	4	10 - 10d	10 - 10d			

For SI: 1 inch = 25.4 mm, 1 lbs = 4.45 N.

¹Truss plies are nominally 2 inches wide.

²The load capacities have been increased for wind or earthquake loading with no further increases allowed. Allowable loads must be reduced when other load durations govern.

³Although the required fastener quantities are for a single TBE connector, the connectors must be installed in pairs as shown in Figure 5.

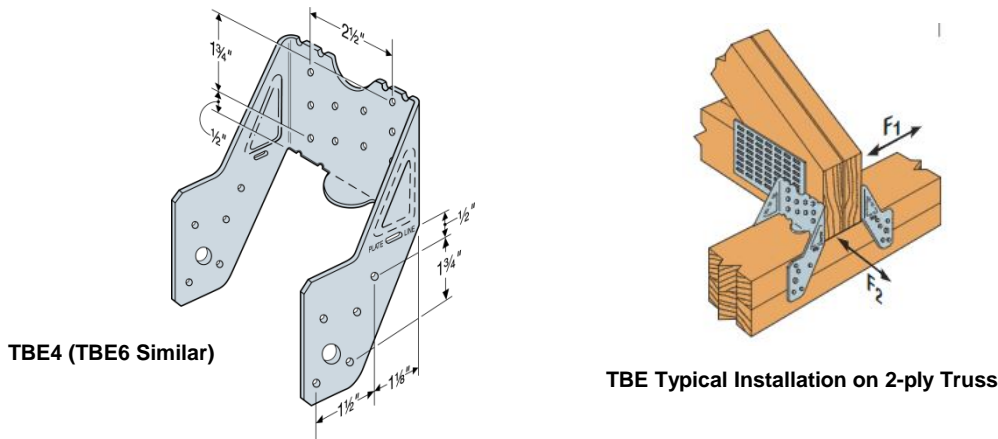

FIGURE 5—TBE TRUSS BEARING ENHANCER

TABLE 6—LTHJA26/THJA26 MULTIPLE TRUSS HANGERS

MODEL NO.	CARRIED MEMBER COMBINATION	FASTENERS (Quantity-Type)			ALLOWABLE LOADS ¹ (lbs)				
		Header	Hip (each)	Jack	Carried Member	Download			
						C _D = 1.6	C _D = 1.0	C _D = 1.15	C _D = 1.25
LTHJA26	Hip & Jack	20-10d	7-10d x 1 1/2	4-10d x 1 1/2	Hip	220	845	845	845
					Jack	75	280	280	280
					Total ³	295	1,125	1,125	1,125
	Double (Terminal) Hip	20-10d	7-10d x 1 1/2	—	Hip (each)	285	630	630	630
					Total	565	1,260	1,260	1,260
THJA26	Hip & Jack	20-16d	6-10d x 1 1/2	4-10d x 1 1/2	Hip	680	2,010	2,080	2,080
					Jack	230	670	695	695
					Total ³	910	2,530	2,845	2,875
	Double (Terminal) Hip	20-16d	6-10d x 1 1/2	—	Hip (each)	480	1,265	1,420	1,430
					Total ³	910	2,530	2,845	2,875

For S1: 1 inch = 25.4 mm, 1 lb = 4.45 N.

¹Tabulated allowable loads must be selected based on duration of load as permitted by the applicable building code.

²The uplift loads have been increased for wind or earthquake loading with no further increases allowed. Allowable loads must be reduced when other load durations govern.

³Total allowable loads (uplift and download) are the loads from all carried members combined (hip and jack, or double hip).

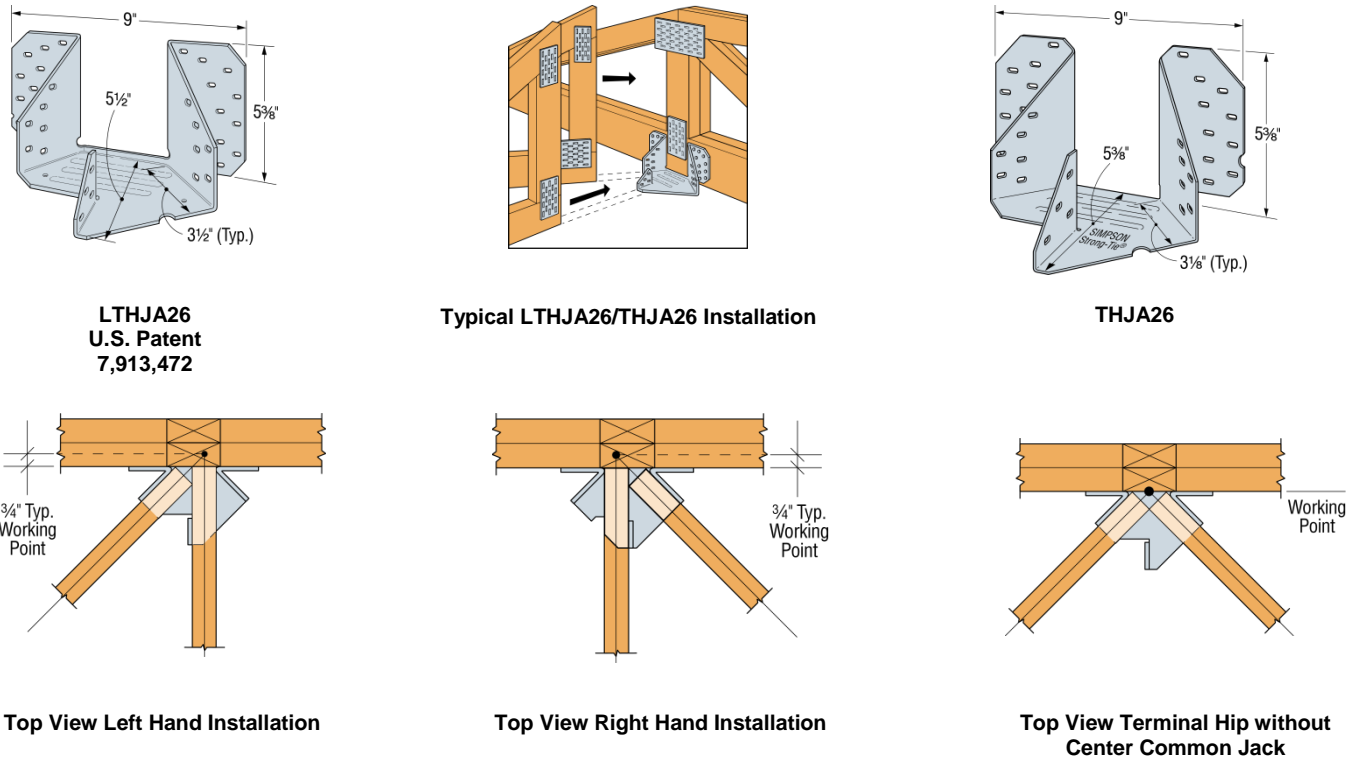

FIGURE 6—LTHJA26 AND THJA26 MULTIPLE TRUSS HANGERS

TABLE 7—LTHMA MULTIPLE-TRUSS HANGER

CARRIED MEMBER COMBINATION	HEADER NOMINAL SIZE	FASTENERS (Quantity-Type)			ALLOWABLE LOADS ^{1,2} (lbs)				
		Header	Hip (each)	Jack	Carried Member	Uplift ²			
						C _D = 1.6	C _D = 1.0	C _D = 1.15	C _D = 1.25
Left and Right Hip & Center Jack	1 ply 2x4	12-10d x 1 1/2	3-10d x 1 1/2	2-10d x 1 1/2	Hip (each)	65	655	660	660
					Jack	15	150	155	155
					Total ³	140	1,460	1,475	1,475
	2 ply 2x4	12-10d	3-10d x 1 1/2	2-10d x 1 1/2	Hip (each)	65	660	700	700
					Jack	15	140	160	160
					Total ³	140	1,460	1,560	1,560
	1 ply 2x6	18-10d x 1 1/2	3-10d x 1 1/2	2-10d x 1 1/2	Hip (each)	65	685	685	685
					Jack	15	155	155	155
					Total ³	140	1,525	1,525	1,525
	2 ply 2x6	18-10d	3-10d x 1 1/2	2-10d x 1 1/2	Hip (each)	85	985	1,085	1,085
					Jack	25	220	245	245
					Total ³	195	2,190	2,415	2,415

For **SI**: 1 inch = 25.4 mm, 1 psi = 6.89 kPa, 1 lbf = 4.45 N.

¹Tabulated allowable loads must be selected based on duration of load as permitted by the applicable building code.

²The uplift loads have been increased for wind or earthquake loading with no further increases allowed. The allowable uplift loads must be reduced when other load durations govern.

³Total allowable loads (uplift and download) are the loads from all carried members combined (left and right hip & center jack). Total load must be evenly distributed about the centerline to avoid eccentric loading.

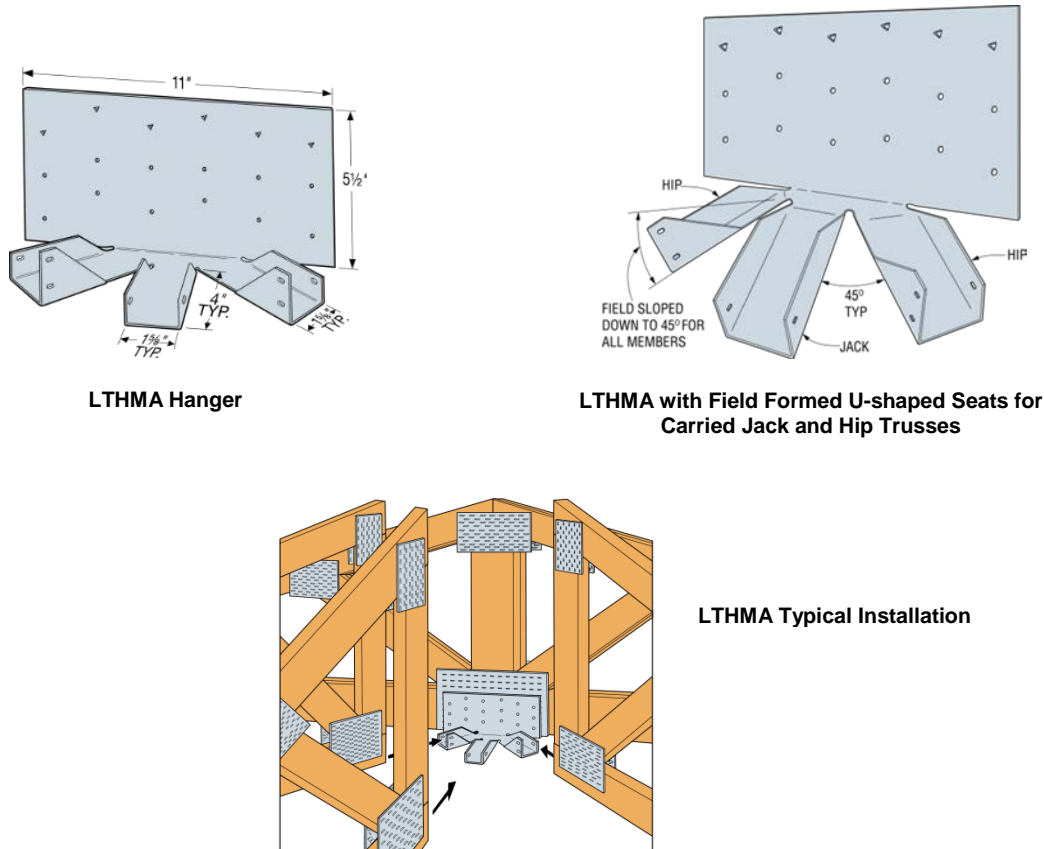

LTHMA Hanger

LTHMA with Field Formed U-shaped Seats for Carried Jack and Hip Trusses

LTHMA Typical Installation

FIGURE 7—LTHMA MULTIPLE-TRUSS HANGER DETAILS

TABLE 8—THJM2-4 AND THJM2-5 MULTIPLE TRUSS HANGERS

MODEL No.	FASTENERS (Quantity-Type)		ALLOWABLE LOADS ^{1,2} (lbs)				
			Uplift ³	Download			
	Header	Carried Truss (Each)	C _D =1.60	C _D =1.00	C _D =1.15	C _D =1.25	C _D =1.60
THJM2-4-SDS3	8-SDS ^{1/4} "x3"	1-SDS ^{1/4} "x3"	535	3270	3270	3270	3270
	8-SDS ^{1/4} "x1 ^{1/2} "	1-SDS ^{1/4} "x3"	535	2000	2300	2500	3030
THJM2-5-SDS3	8-SDS ^{1/4} "x3"	1-SDS ^{1/4} "x3"	620	3360	3765	3765	3765
	8-SDS ^{1/4} "x1 ^{1/2} "	1-SDS ^{1/4} "x3"	620	2000	2300	2500	3030

For SI: 1 inch = 25.4 mm, 1 pound = 4.45 N.

¹Tabulated allowable loads must be selected based on duration of load as permitted by the applicable building code.

²Tabulated allowable loads are the total allowable loads of all carried trusses combined; the load on any single carried truss must not exceed 25 percent of the total published load for the THJM2-4 or 20 percent for the THJM2-5.

³The uplift loads have been increased for wind or earthquake loading with no further increases allowed. The allowable uplift loads must be reduced when other load durations govern.

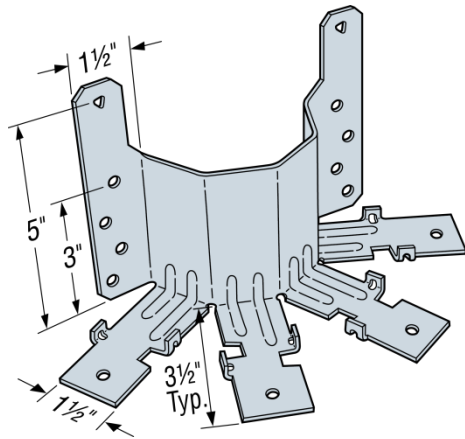

THJM2-4-SDS3

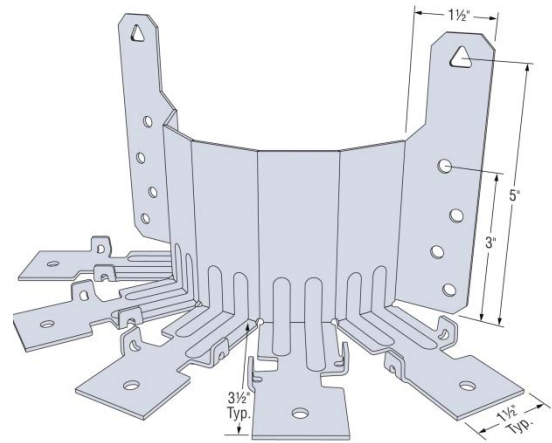

THJM2-5-SDS3

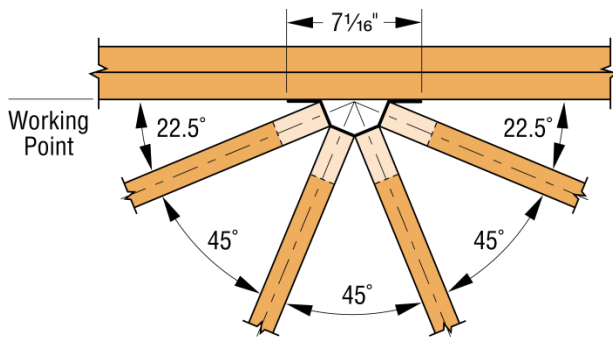

Typical THJM2-4 Installation Top View

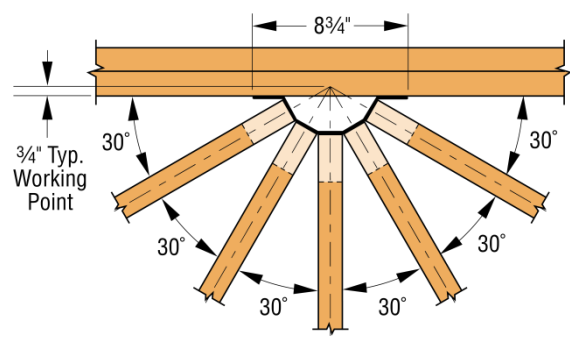

Typical THJM2-5 Installation Top View

FIGURE 8—THJM2-4 AND THJM2-5 MULTIPLE TRUSS HANGERS

TABLE 9—THJU26 AND THJU26-W MULTIPLE TRUSS HANGERS

MODEL No.	Carried Member Combination	Dimensions ¹ (inches)			FASTENERS (Quantity-Type)			ALLOWABLE LOADS ^{2,3,4} (lbs)		
		W	H	B	Header	Hip	Jack	Uplift ⁵ C _D =1.6	Download	
									C _D = 1.0	C _D = 1.15 C _D = 1.25 C _D = 1.60
THJU26	Min. 2x4 Hip & Jack	5 ¹ / ₈	5 ³ / ₈	3 ¹ / ₂	16-10d	4-10d	4-10d	780	1,915	1,915
	7-10d					7-10d	1,310	2,250	2,350	
THJU26-W	Min. 2x4 Hip & Jack	7 ⁷ / ₈	5 ³ / ₈	3 ¹ / ₂	16-10d	4-10d	4-10d	685	1,825	1,825
	7-10d					7-10d	1,240	1,965	1,965	

For SI: 1 inch = 25.4 mm, 1 pound = 4.45 N.

¹Refer to Figure 9 for definitions of hanger nomenclature.

²Tabulated allowable loads must be selected based on duration of load as permitted by the applicable building code.

³Tabulated allowable loads are applicable to nonskewed jacks and hip skews of 45-degrees for the THJU26 and 67.5-degrees for the THJU26-W.

⁴Tabulated allowable loads are the total allowable loads of the hip and jack members combined. The load on the hip must not exceed 65 percent of the total load, and the load on the jack member must not exceed 35 percent of the total load.

⁵The uplift loads have been increased for wind or earthquake loading with no further increases allowed. The allowable uplift loads must be reduced when other load durations govern.

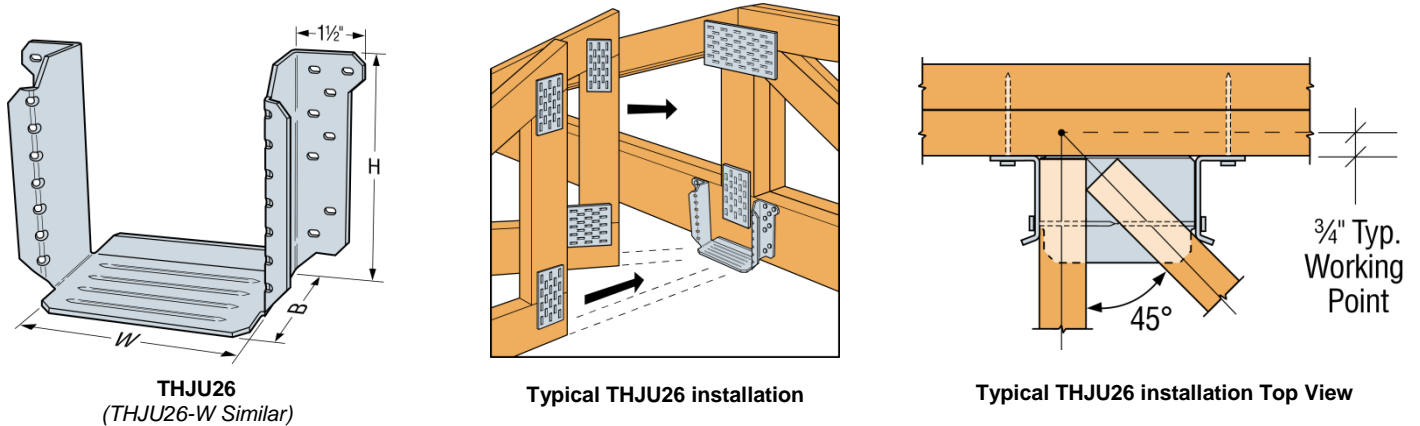

FIGURE 9—THJU26 AND THJU26-W MULTIPLE TRUSS HANGERS

TABLE 10—DSC SERIES DRAG STRUT CONNECTORS

MODEL NO.	FASTENERS (Total Quantity - Type)	LENGTH (Inches)	ALLOWABLE LOADS ¹ (lbs) C _D = 1.6	
			Compression	Tension
DSC2R/L-SDS3	20-SDS ¹ / ₄ x3"	16	2,590	3,720
DSC5R/L-SDS3	24-SDS ¹ / ₄ x3"	21	4,340	4,150

For SI: 1 inch = 25.4 mm, 1 pound = 4.45 N.

¹Allowable loads have been increased for wind or earthquake loading with no further increases allowed. Allowable loads must be reduced when other load durations govern.

²Tabulated allowable loads require the fasteners to have a minimum edge distance of ⁵/₈ inch, and minimum end distance of 2¹/₂ inches for the DSC2 and 3³/₄ inches for the DSC5.

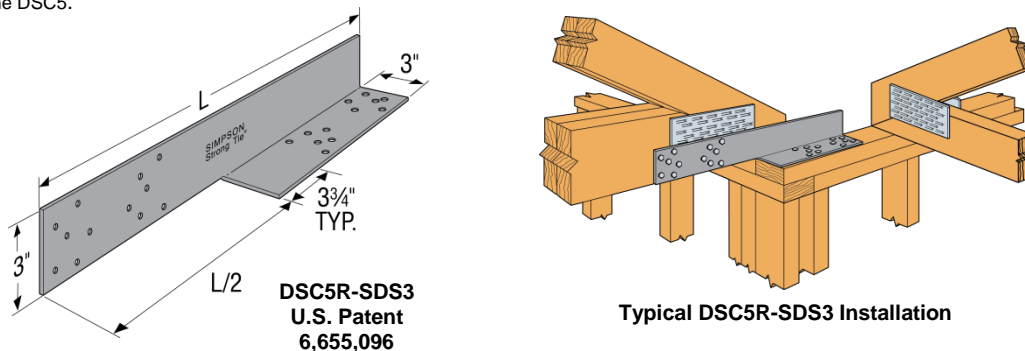

FIGURE 10—DSC DRAG STRUT CONNECTORS

TABLE 11—AHEP ADJUSTABLE HIP-END CONNECTOR¹

MODEL NO.	FASTENERS (Total Quantity-Type)			LENGTH ^{6,7} (Inches)	PITCH ⁵	ALLOWABLE DOWNLOADS FOR CONNECTOR AND SHEATHING COMBINED ^{2,3,4,9,10} (lbs) C _D = 1.0; C _D = 1.15; C _D = 1.25	
	AHEP Side Flanges ⁶	Hip Trusses ⁸	Sheathing -to-AHEP ³			L/180 Max. Deflection ³	³ / ₁₆ " Max. Deflection ³
AHEP	4-#10x ³ / ₄ "	4-10d	#8 Screws at 12"o.c.	19 ³ / ₄ to 30	3:12	250	345
					3.1:12	210	275
					6:12	185	225
					9:12	160	175

For SI: 1 inch = 25.4 mm, 1 pound = 4.45 N.

¹The AHEP connectors are used as structural purlins in hip-end systems to support the roof sheathing and transfer live and dead loads to the step-down hip trusses or framing members. The designer must insure the wood members are adequately designed to resist the applied loads.

²Tabulated allowable loads are applicable to installations on wood framing members spaced up to 24 inches on center, with roof sheathing directly attached to the AHEP using low-profile head, self-drilling No. 8 screws at 12 inches on center or less. The roof sheathing must have a minimum nominal thickness of ¹⁵/₃₂ inch with a minimum span rating of 32/16, and may be oriented with the strength axis either parallel or perpendicular to the long axis of the AHEP.

³Tabulated allowable downloads are for concentrated loads applied to the roof sheathing at any point along the length of the AHEP, and must be selected based on allowable maximum deflection (L/180 or ³/₁₆ inch) as determined by the designer.

⁴The tabulated allowable loads may not be increased.

⁵Straight line interpolation can be used to determine allowable loads for pitches between 3.1-in-12 and 9-in-12. Use of the AHEP for roof pitches less than 3:12 or greater than 9:12 are outside the scope of this report.

⁶Prior to installation, the AHEP must be set to the calculated sloping length (from leading edge to leading edge of the step-down hip trusses), and the inner and outer tubes must be fastened together with (4)-#10x³/₄" self-drilling screws through the round holes in the side flanges. The #10 self-drilling screws must have a nominal diameter of 0.190" and must comply with [ASTM C1513](#).

⁷Minimum AHEP Length is 21 inches at the 3-in-12 pitch and 19³/₄ inches at pitches of 4-in-12 and higher. Minimum lengths for pitches between 3-in-12 and 4-in-12 shall be determined using straight line interpolation. Maximum AHEP length at each pitch is the calculated sloping length between framing members spaced at 24 inches on center.

⁸The two 10d common nails at the bottom (lower end) of the AHEP must be clinched on the back side of 2x framing members.

⁹The AHEP must be free of dents or other deleterious deformations at the time of installation and in service.

¹⁰The AHEP has not been evaluated for uplift resistance.

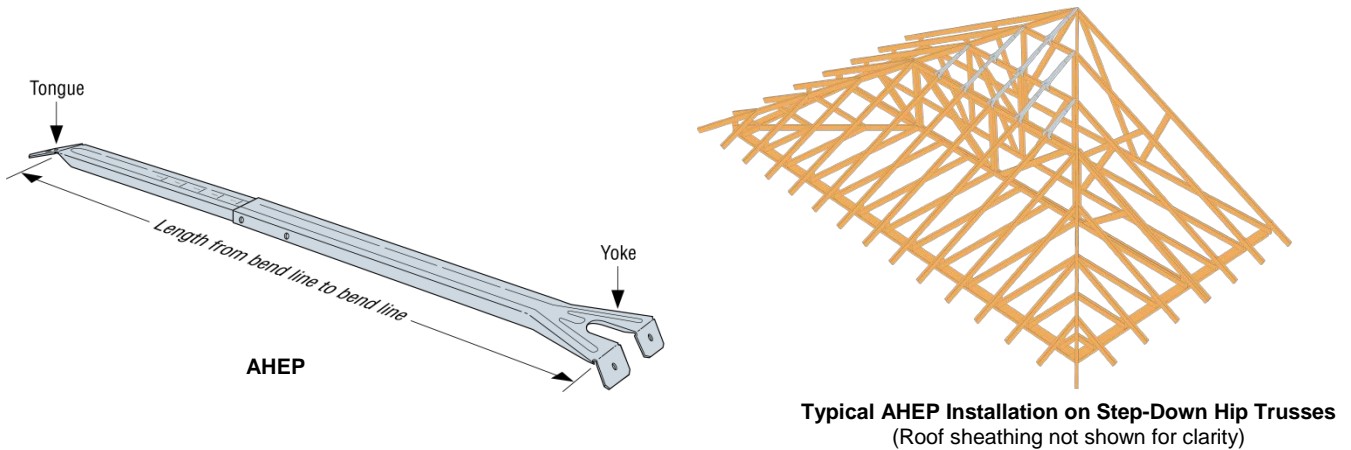

FIGURE 11—AHEP ADJUSTABLE HIP-END CONNECTOR