

# SYSTEM 1

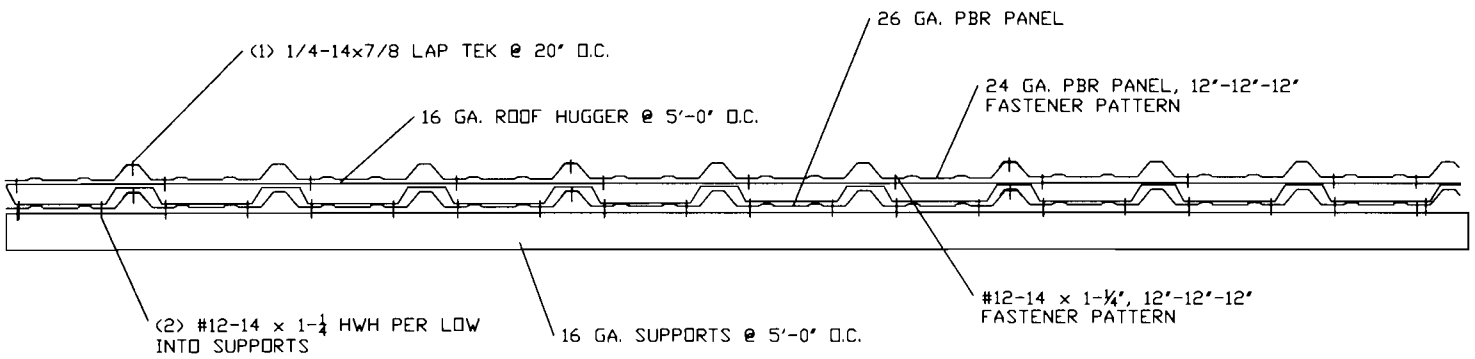

# SYSTEM 2

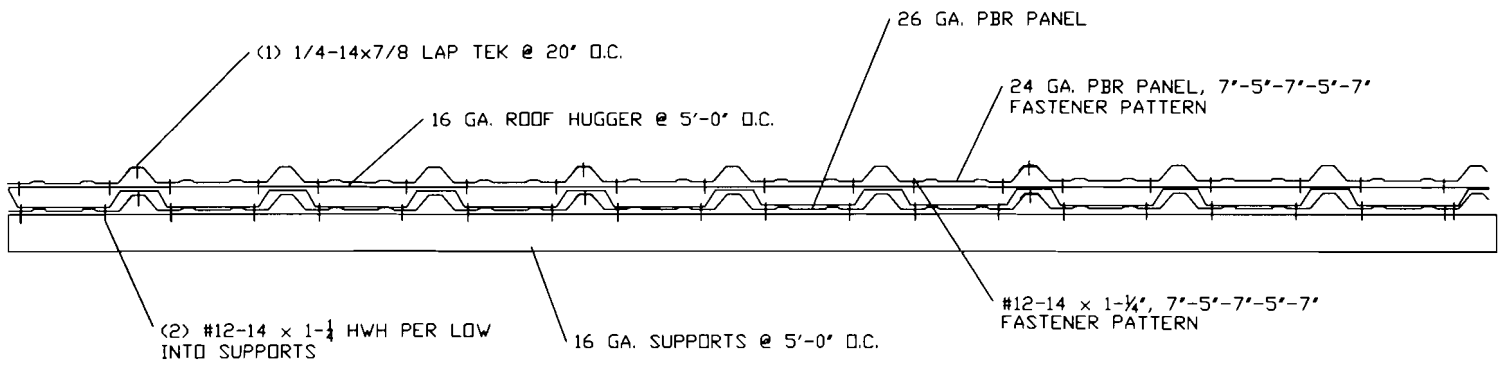

# SYSTEM 3 HATS @ 24" O.C. SECTION A-A @ SUPPORT

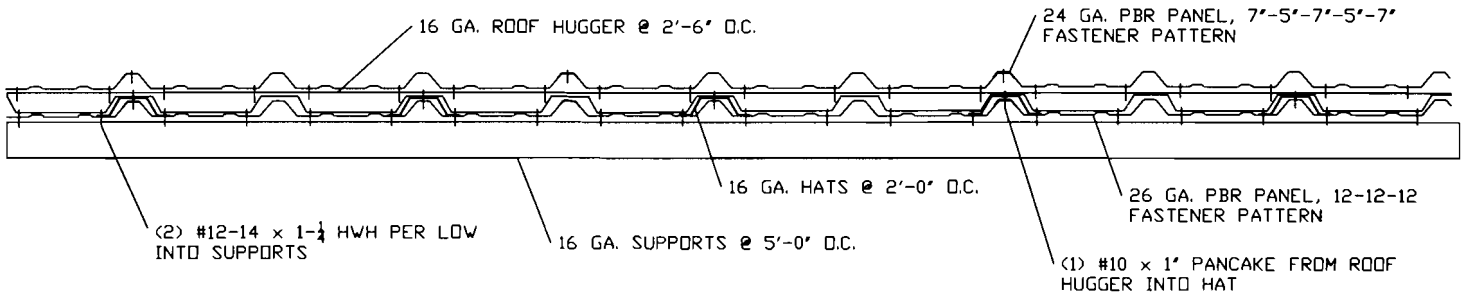

# SECTION B-B @ MIDSPAN

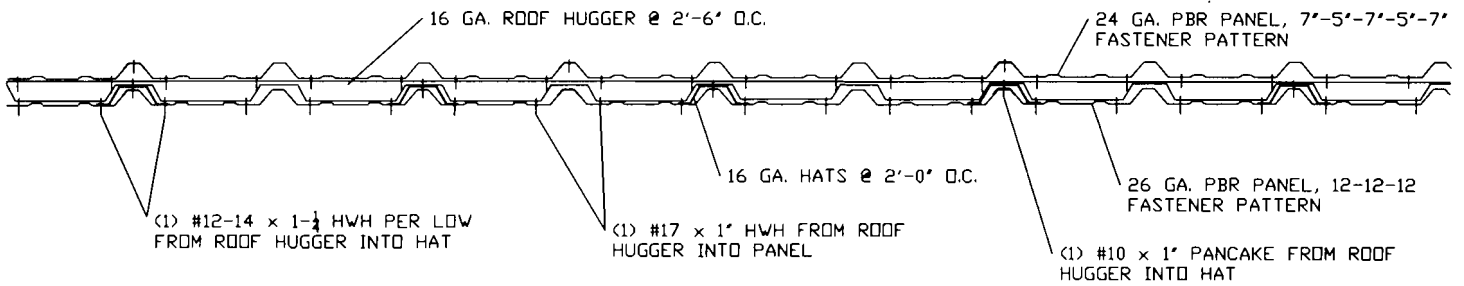

# SYSTEM 4

## HATS @ 12" O.C.

### SECTION A-A @ SUPPORT

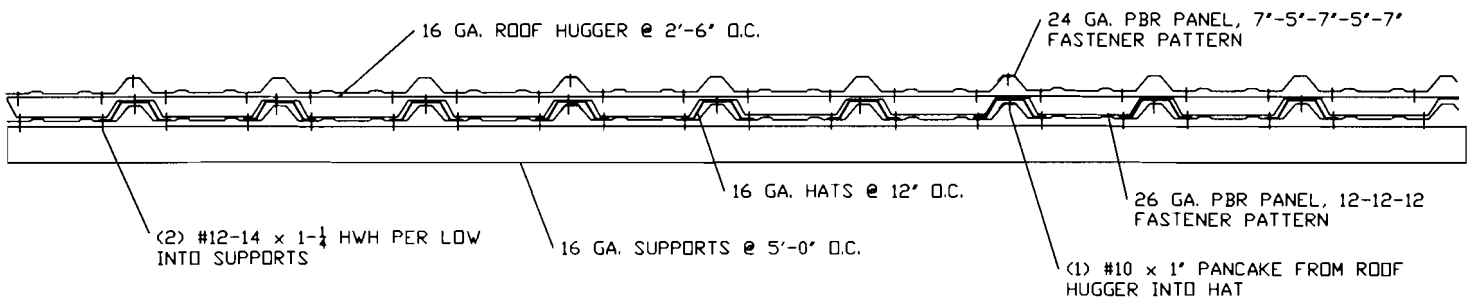

### SECTION B-B @ MIDSPAN

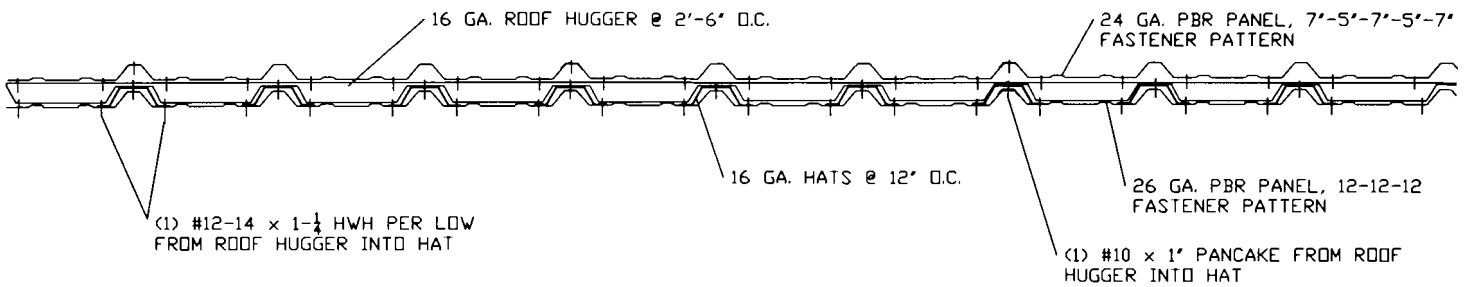

TYPICAL  
"PBR" PANEL

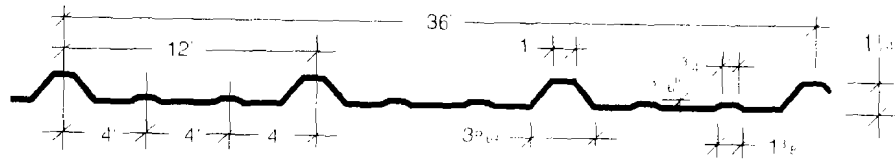

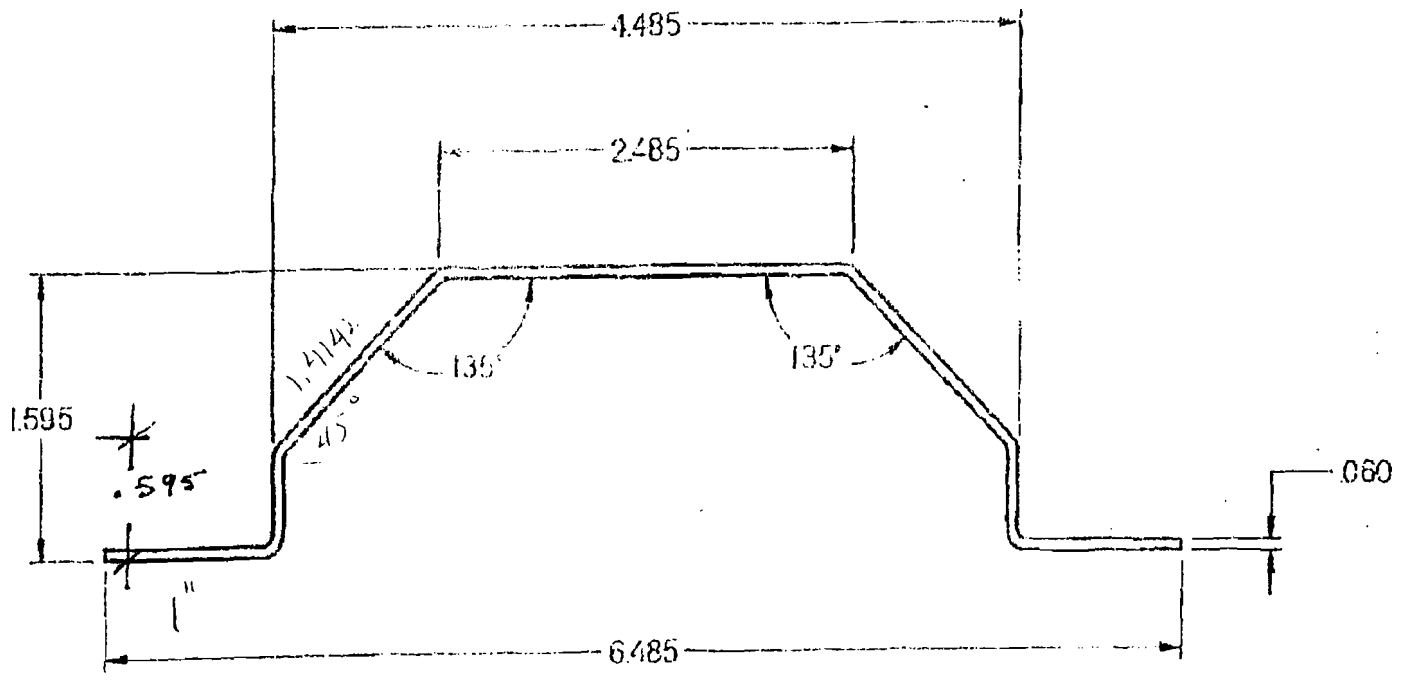

**TOLERANCES**  
 Unless otherwise specified dimensions are in inches.  
 Fractions  $\pm 1/54$  Holes  $-.001 \pm .003$  Angles  $\pm 3^\circ$   
 Decimals .X  $\pm .060$  .XX  $\pm .030$  .XXX  $\pm .015$

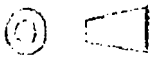

1 Chamfered Project



1407 West Kennedy, Brandon, Florida 33636  
 Phone (813) 254-8845 Fax (813) 254-7399  
 Website: <http://www.roofhangers.com>

Job No	Error: No reference
Cost	Error: No reference
Dwg No	Error: No reference
Title	Error: No reference
Author	Error: No reference

Stored	DATA\JOHN
PO No	
Date Modified	12/16/2006
Date Created	12/16/2006
Checked	

Rev: Error: No ref  
 Sheet 3 of 6

# Our Patented Design is Simple, Strong - Effective!

## TYPICAL SHOP DRAWING FOR FABRICATION ROOF HUGGER PRODUCT

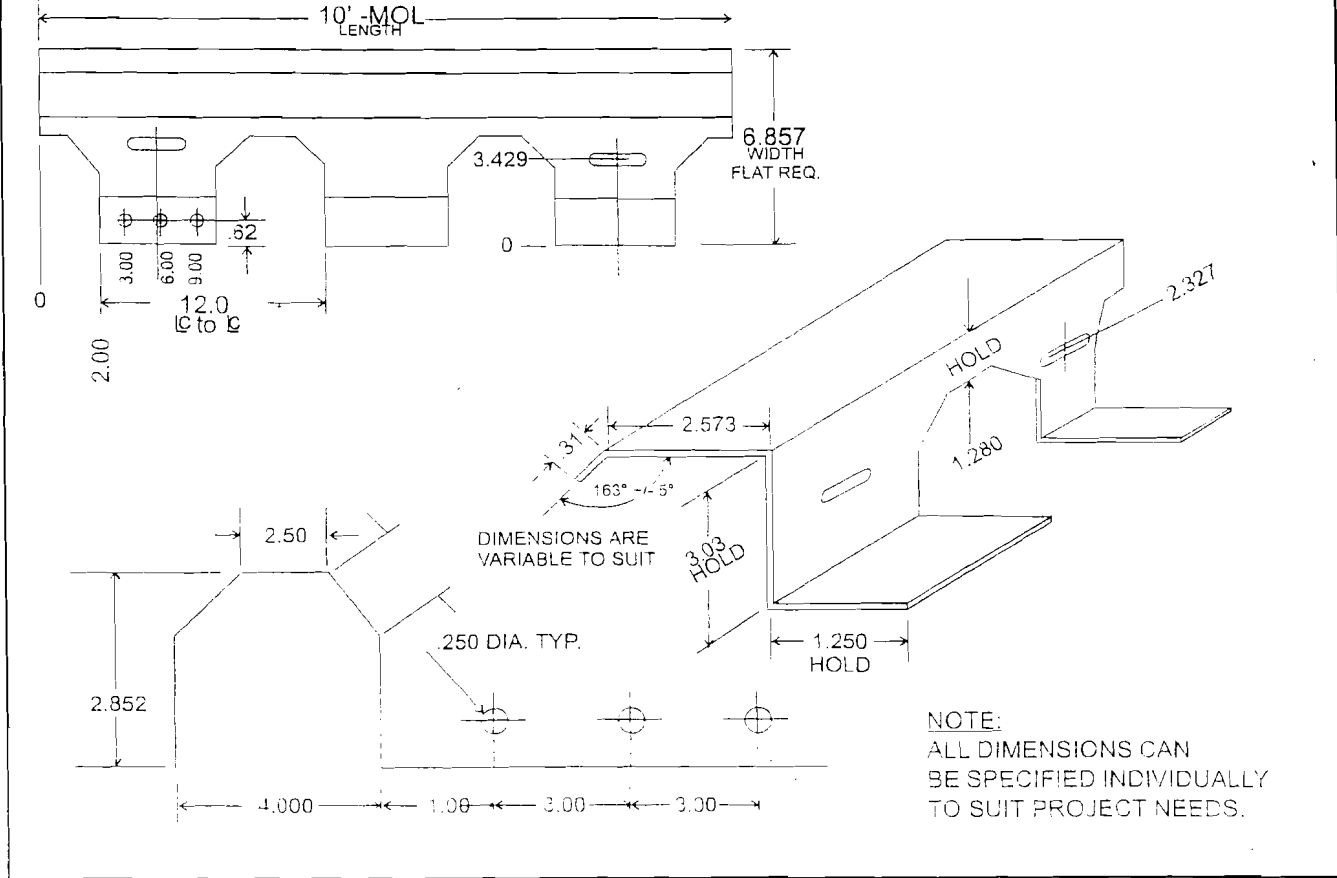

## A Partial Sampling of Available Hugger Profiles

Vertical Standing Seam 12" - 24"

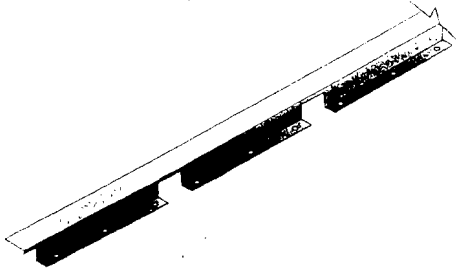

6" - 10" o.c. Special Cutout

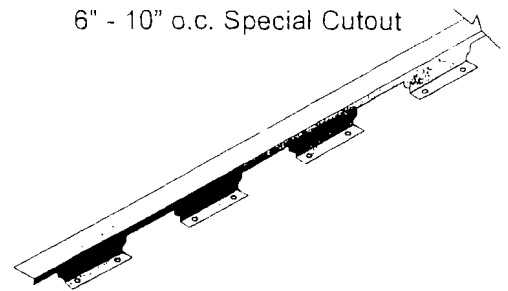

2.67" - 4.2" Corrugated

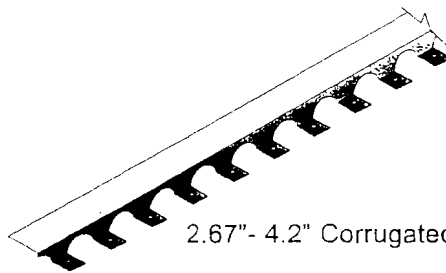

All profiles produced in +/- 10' lengths.

Hugger with Major and Minor-Rib Cutout

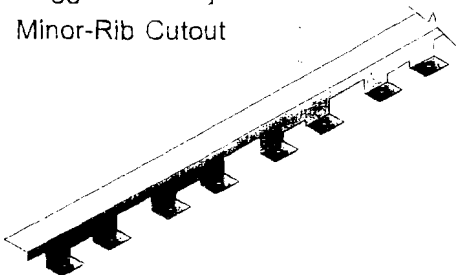

12" o.c. - 1'-1" R-Panel

