

**EVALUATION REPORT OF
METAL SALES MANUFACTURING CORPORATION
'24 GA., 7/8" CORRUGATED PANEL'**

**FLORIDA BUILDING CODE 6TH EDITION (2017)
FLORIDA PRODUCT APPROVAL
FL 9482.1-R5
PANEL WALLS
SIDING**

**Prepared For:
Metal Sales Manufacturing Corporation
545 South 3rd Street, Suite 200
Louisville, KY 40202
Telephone: (502) 855-4300
Fax: (502) 855-4200**

**Prepared By:
Bala Sockalingam, Ph.D., P.E.
Florida Professional Engineer #62240
1216 N Lansing Ave., Suite C
Tulsa, OK 74106
Telephone: (918) 492-5992
FAX: (866) 366-1543**

**This report consists of
Evaluation Report (2 Pages including cover)
Installation Details (1 Page)
Load Span Table (1 Page)**

**Report No. C2179-1
Date: 8.23.2017**



Manufacturer: Metal Sales Manufacturing Corporation

Product Name: 7/8" Corrugated

Panel Description: 34.67" wide coverage with (14) 7/8" high ribs spaced at 2.67" o.c.

Materials: Min 24 ga. 50 ksi steel. Galvanized coated steel (ASTM A653) or Galvalume coated steel (ASTM A792) or painted steel (ASTM A755)

Support Description: Min 16 ga., 50 ksi steel section (Must be designed by others)

Design Pressure: ±175 psf @ support spacing of 24" o.c.
±30 psf @ support spacing of 96" o.c.

Panel Attachment: #12-14 x 1.25" long SDS with washer @ 8" o.c. across panel width

Sidelap Attachment: ¼"-14 x 7/8" long SDS with washer @ 12" o.c.

Test Standards: Wall assembly tested in accordance with ASTM E330-02 'Standard Test Method for Structural Performance of Exterior Windows, Doors, Skylights and Curtain Walls by Uniform Static Air Pressure Difference.'

Code Compliance: The product described herein has demonstrated compliance with FBC 2017 Section 1404.5.

Product Limitations: Design wind loads shall be determined for each project in accordance with FBC 2017 Section 1609 or ASCE 7-10 using allowable stress design. The maximum support spacing listed herein shall not be exceeded. The design pressure for reduced support spacing may be computed using rational analysis prepared by a Florida Professional Engineer or based on Metal Sales' load span table. This evaluation report is not applicable in High Velocity Hurricane Zone.

Supporting Documents: ASTM E330 Test Reports
Farabaugh Engineering and Testing Inc.
Project No. T170-09, Reporting Date 4/29/09

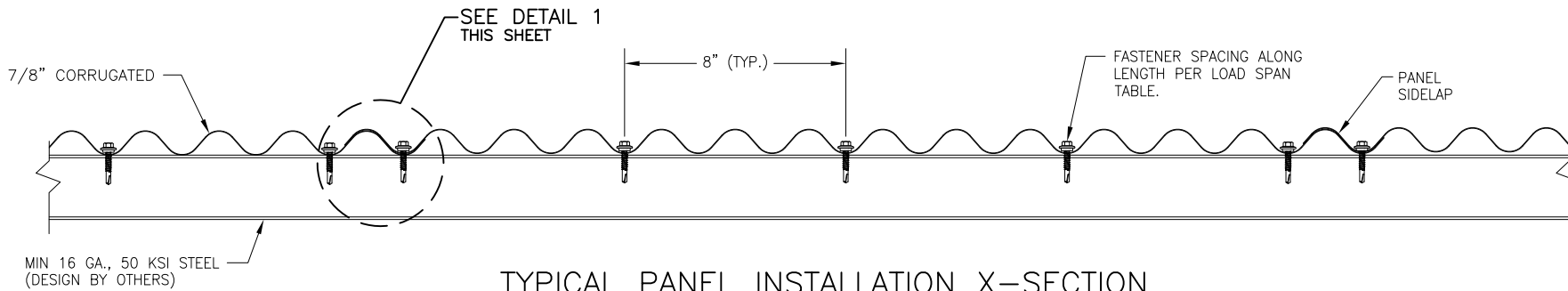

TYPICAL PANEL INSTALLATION X-SECTION

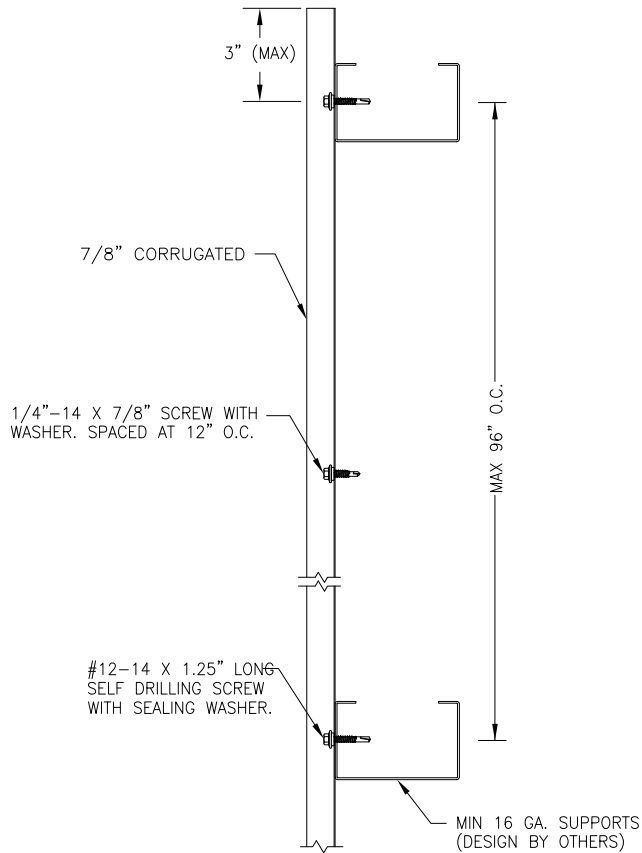

SECTION VIEW

GENERAL NOTES:

1. STRUCTURAL WALL PANEL HAS BEEN DESIGNED IN ACCORDANCE WITH THE FLORIDA BUILDING CODE (FBC).
2. WALL PANELS ARE SHALL BE 24 GA. (0.022"). EFFECTIVE COVERING WIDTH OF PANEL = 34.67".
3. WALL PANELS SHALL BE INSTALLED OVER STRUCTURE AS SPECIFIED ON THIS DRAWING.
4. REQUIRED DESIGN WIND LOADS SHALL BE DETERMINED FOR EACH PROJECT. THIS PANEL SYSTEM MAY NOT BE INSTALLED WHEN THE REQUIRED DESIGN WIND LOADS ARE GREATER THAN THE ALLOWABLE WIND LOADS SPECIFIED ON THIS DRAWING.
5. ALL FASTENERS MUST BE IN ACCORDANCE WITH THIS DRAWING & THE FLORIDA BUILDING CODE. IF A DIFFERENCE OCCURS BETWEEN THE MINIMUM REQUIREMENTS OF THIS DRAWING & THE CODE, THE CODE SHALL CONTROL.
6. SUPPORTS MUST BE DESIGNED TO WITHSTAND WIND LOADS AS REQUIRED FOR EACH APPLICATION AND ARE THE RESPONSIBILITY OF OTHERS.
7. PANELS MAY SPAN BETWEEN BOTTOM AND TOP SUPPORTS (WALL APPLICATION WITH PANELS ORIENTED VERTICALLY), SIDE TO SIDE BETWEEN CORNER WITH PANELS ORIENTED VERTICALLY), SIDE TO SIDE BETWEEN CORNER SUPPORTS (WALL APPLICATION WITH PANELS ORIENTED HORIZONTALLY) OR UNDER ROOF (SOFFIT APPLICATION WITH PAINTED SURFACE FACING DOWNWARD).

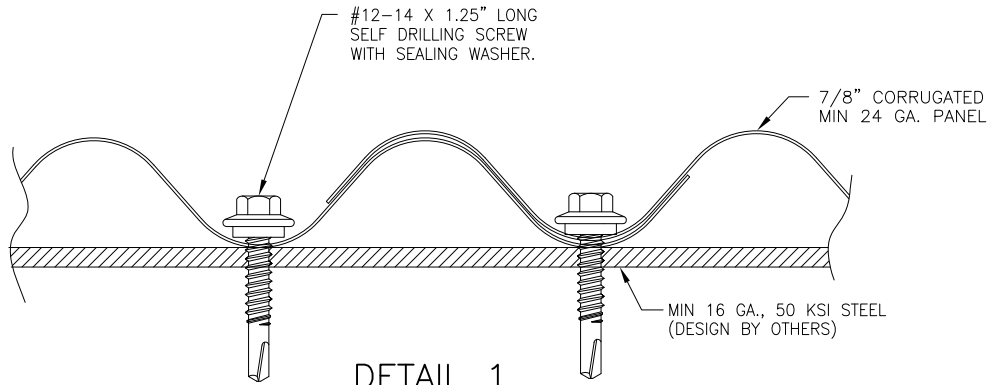

DETAIL 1

DRAWN BY: B.S.	CHECKED BY: D.S.
PLLOT:	DATE: 3/20/15
DATE	
BY	
REVISION DESCRIPTION	
NO.	
DRAWING TITLE 7/8" CORRUGATED PANEL	
CONSULTANTS BALA SOCKALINGAM, P.H.D., P.E.	MANUFACTURER METAL SALES MANUFACTURING CORP.
1216 N LANSING AVE, SUITE C TULSA, OK 74106 PHONE: 918-492-5992	545 SOUTH 3RD ST., SUITE 200 LOUISVILLE, KY 40202 502-855-4300
DRAWING NO. 2179-1	REV.
PAGE NO. 1	OF 1

METAL SALES CORPORATION
7/8" CORRUGATED PANEL
34.67" wide coverage , 24 ga. (min) Steel Panel

Span Condition	Loading Type	Allowable Load (psf)								
		Support Spacing (ft)								
		2.00	2.50	3.00	3.50	4.00	5.00	6.00	7.00	8.00
Two Span	Positive or Negative	158.5	126.8	105.7	90.6	79.2	63.4	52.8	39.2	30.0
Three Span	Positive or Negative	175.0	144.1	120.1	102.9	90.0	67.2	46.7	34.3	26.3
Four or More Spans	Positive or Negative	173.3	138.7	115.5	99.0	86.7	69.3	48.5	35.6	27.3

Notes:

1. Allowable load for each condition is the smallest load calculated based on fastener capacity, panel strength and and deflection limit of L/120. Allowable loads are calculated for minimum 24 ga. panel.
2. The wind load is taken as 0.7 times the "component and cladding" loads for the purpose of determining deflection limit.
3. The panel allowable properties are determined from full scale ASTM E330-02 test at 2' 0" & 8' 0" spans.
4. The panel fasteners are #12-14 x 1-1/4" long self drilling fastener with washer.
5. Sidelap fasteners are 1/4"-14 x 7/8" long self drilling screws with washer at 12" o.c.
6. Steel supports are minimum 16 ga.. All supports must be designed to resist all loads imposed on the panel.
7. Panels must be installed as per Evaluation Report FL 9482.1 and Metal Sales current installation procedure.



1216 N Lansing Ave., Suite C
Tulsa, Ok 74106
918 492 5992

Bala Sockalingam, Ph.D., P.E.
FL 62240