

REVISIONS			
REV	DESCRIPTION	DATE	APPROVED
A	REVISED NOTE 1	02/02/12	R.L.
B	REVISED PER HVHZ REQUIREMENTS	05/10/12	R.L.
C	REVISED HEIGHT	06/04/12	R.L.

- NOTES:
- 1) THE PRODUCT SHOWN HEREIN IS DESIGNED AND MANUFACTURED TO COMPLY WITH THE 2010 FLORIDA BUILDING CODE, INCLUDING THE HVHZ.
 - 2) WOOD FRAMING AND MASONRY OPENING TO BE DESIGNED AND ANCHORED TO PROPERLY TRANSFER ALL LOADS TO STRUCTURE. FRAMING AND MASONRY OPENING IS THE RESPONSIBILITY OF THE ARCHITECT OR ENGINEER OF RECORD.
 - 3) CONTRACTOR IS RESPONSIBLE FOR MAINTAINING STRUCTURAL INTEGRITY OF WINDOW OPENING AND ALL WOOD FRAMING AROUND WINDOW.
 - 4) ALL EXTRUSIONS ARE 6063-T5 ALUMINUM ALLOY, UNLESS OTHERWISE NOTED.
 - 5) ALL FASTENERS, NUTS AND WASHERS SHALL BE GALVANIZED OR STAINLESS STEEL WITH A MINIMUM TENSILE STRENGTH OF 60KSI.
 - 6) APPLICABLE TEST REPORT: CTLA 1606W, CTLA 1609W, HTL 0432-0804-06 AND FTL 5278
 - 7) REFER TO ANCHOR SCHEDULE CHART FOR ANCHOR TYPE, SUBSTRATE TYPE, EDGE DISTANCE AND MINIMUM EMBEDMENT.
 - 8) FOR MINIMUM REQUIRED SEPARATION BETWEEN PRODUCT AND EXISTING GLASS AND RATED DESIGN PRESSURES SEE DESIGN PRESSURE CHART ON SHEET 3.
 - 9) UNITS MAY BE MULLED TOGETHER INDEFINITELY USING APPROVED MULLIONS AS REQUIRED.
 - 10) FOR UNITS WITH STORM BARS SEE CHARTS AND INSTALLATION DETAILS ON SHEET 3.
 - 11) OPERATION OF ROLLUP MECHANISM IS NOT PART OF THIS APPROVAL. CARE SHOULD BE TAKEN WHEN SHUTTER IS IN MOTION ENSURING THAT PERSONAL INJURY OR DAMAGE TO THIS PRODUCT DOES NOT OCCUR.
 - 12) FOR DESIGN PRESSURES FOR UNITS WITHOUT STORM BARS AND WITH OR WITHOUT END RETENTION SYSTEM SEE SHEET 3.
 - 13) SLATS CAN BE INSTALLED WITH EITHER PROFILE FACING THE EXTERIOR.
 - 14) HOOD ASSEMBLY IS IMPACT RATED AND MAY BE PLACED INSIDE FRAME OPENING AS AN EXPOSED FEATURE.

ROLL-UP SHUTTER-IN-A-BOX
EXTERIOR VIEW

DESIGN PRESSURE RATING	IMPACT RATING
±23.7PSF	LARGE AND SMALL MISSILE IMPACT

MISSILE LEVEL D, WIND ZONE 4, AND HVHZ.
SEE CHART IN SHEET 3 FOR OTHER SIZES AND GLASS SEPARATION

TABLE OF CONTENTS	
SHEET NO.	DESCRIPTION
1	ELEVATION ANCHORING AND GENERAL NOTES
2	STORM BAR ELEVATION AND LOCATION
3	B.O.M. AND DESIGN PRESSURE CHARTS
4, 5	INSTALLATION DETAILS
6, 7	ANCHOR CHARTS
8, 9	INSTALLATION DETAILS
10	COMPONENTS

USA SHUTTER COMPANY LLC
1450 RAIL HEAD BLVD
NAPLES, FL 34110

ALUMINUM MAESTROSHIELD
SHUTTER-IN-A-BOX
ELEVATION, ANCHORING AND NOTES

DRAWN: R.L.	DWG NO. 08-00174	REV C
SCALE NTS	DATE 06/25/07	SHEET 1 OF 10

SIGNED: 06/04/2012



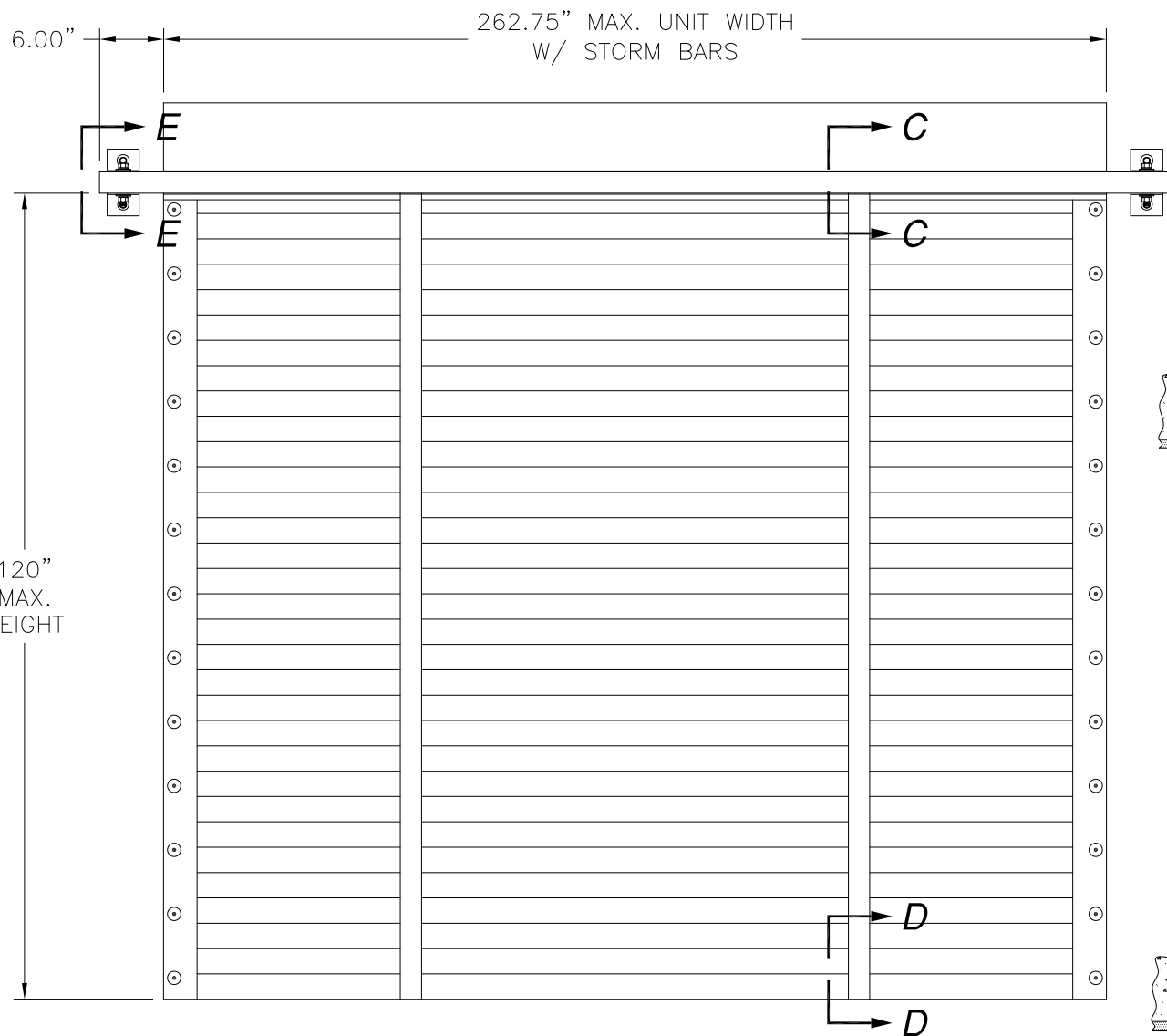

**ROLL-UP SHUTTER-IN-A-BOX WITH
STORM BARS
EXTERIOR VIEW**

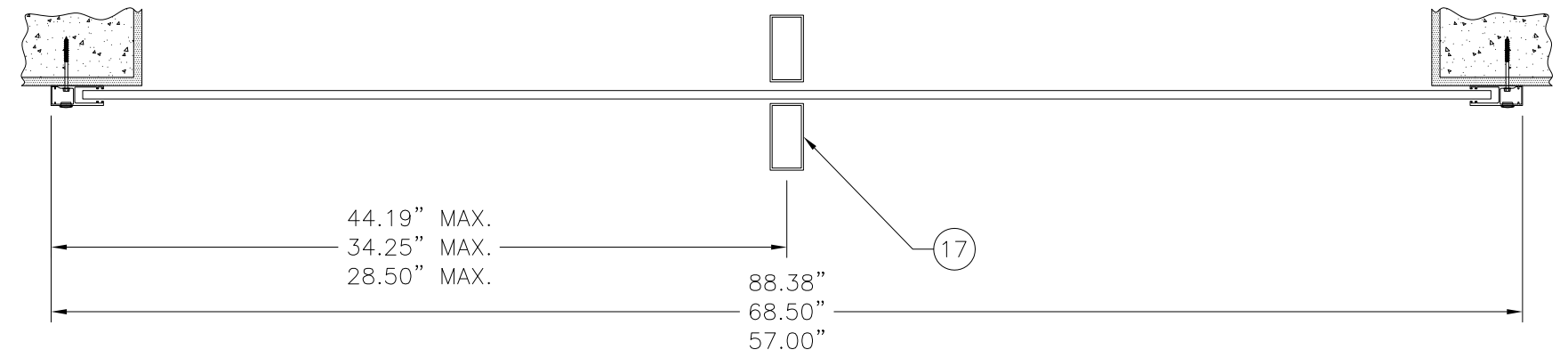

**STORM BAR LOCATION
FOR 88.38\", 68.50\" AND 50.78\"
UNITS WITH ONE STORM BAR**

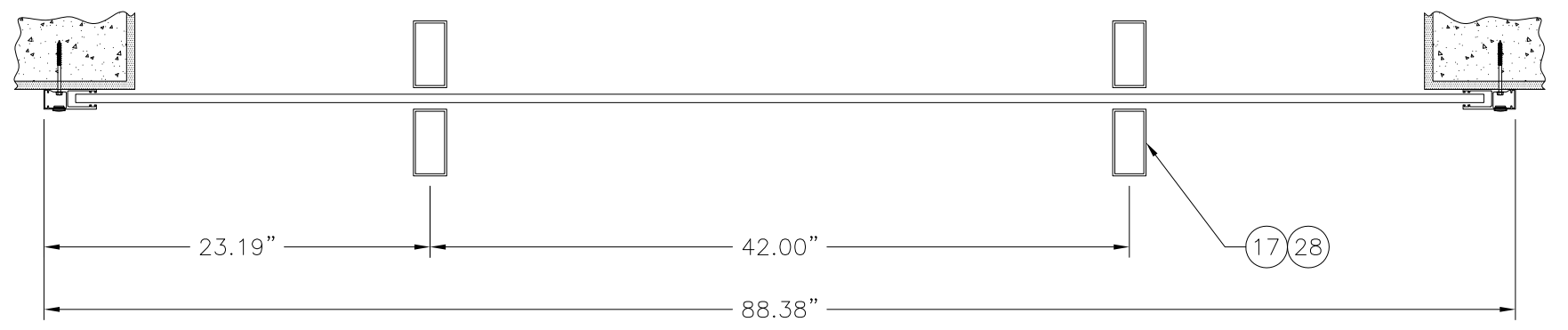

**STORM BAR LOCATION
FOR 88.38\" WIDE UNITS WITH TWO
STORM BARS**

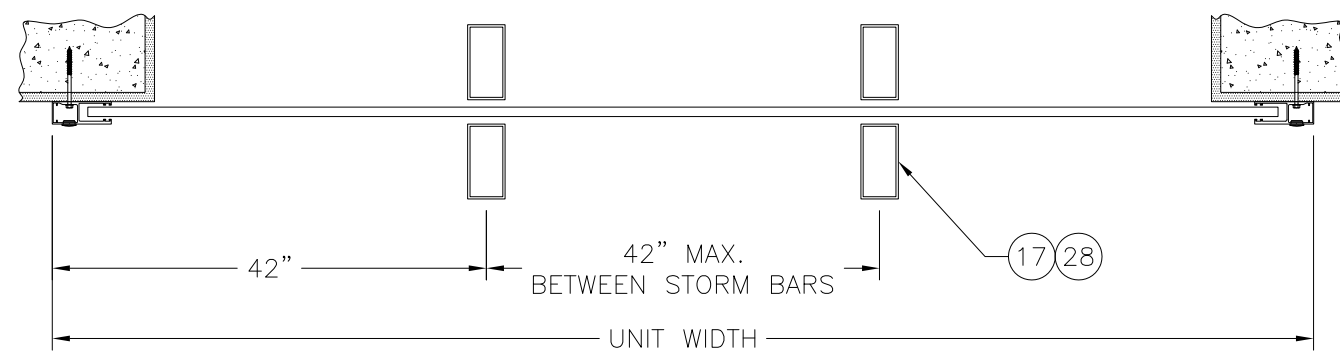

**STORM BAR LOCATION
FOR UNITS WIDER THAN 88 3/8\"**

REVISIONS			
REV	DESCRIPTION	DATE	APPROVED
A	REVISED NOTE 1	02/02/12	R.L.
B	REVISED PERGVHYZ REQUIREMENTS	06/00/12	R.L.
C	REVISED HEIGHT	06/04/12	R.L.

USA SHUTTER COMPANY LLC
1450 RAIL HEAD BLVD
NAPLES, FL 34110

ALUMINUM MAESTROSHIELD
SHUTTER -IN-A-BOX
STORM BAR ELEVATION AND LOCATION

DRAWN: R.L.	DWG NO. 08-00174	REV C
SCALE NTS	DATE 06/25/07	SHEET 2 OF 10

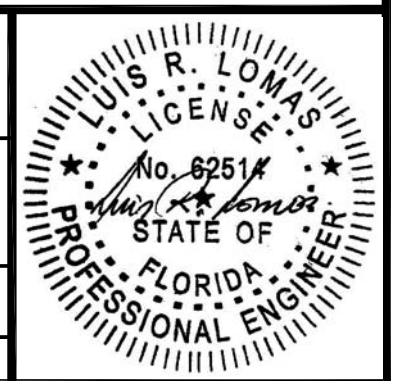

PARTS LIST	
NO.	DESCRIPTION
1	HOOD ALUMINUM
2	HOOD FRONT, ALUMINUM
3	BRACKET RIGHT, ALUMINUM
4	MOTOR TUBE, ALUMINUM
5	MOTOR
6	BRACKET LEFT, ALUMINUM
7	MOTOR MOUNT NUTS
8	SIDE RAIL, ALUMINUM
9	SLAT, ALUMINUM
10	STANDARD BUILD-OUT, ALUMINUM
11	OPTIONAL BUILD-OUT, ALUMINUM
12	#14 x 3/4" SMS
13	IDLE BEARING HOUSING, ALUMINUM
14	BOTTOM SLAT, ALUMINUM
15	HEADER 2x4x1/8" ALUMINUM 6063-T5
16	2x4 SPRING BLOCK ASSEMBLY
17	STORM BAR 2x4x1/8" ALUMINUM 6063-T5
18	#10 TEK SELF TAPPING SCREW
19	POWER BOLT 1/2"x3"
20	LAG SCREW 1/2"x3"
21	BOLT HH 1/2-13x3" WITH WASHERS AND NUTS
22	MOUNTING ANGLE 2x4x1/8" 3" LONG
23	SPACER
24	END RETENTION - RIGHT
25	END RETENTION - LEFT
26	SIDE RAIL FOR END RETENTION, ALUMINUM (OPTIONAL)
27	HEADER U-CHANNEL ALUMINUM 6063-T5
28	STORM BAR 2x6x1/8 ALUMINUM
29	MOUNTING ANGLE
30	2x3 SPRING BLOCK ASSEMBLY
31	SIDE RAIL FOR END RETENTION, ALUMINUM

Maximum design pressure capacity chart (psf)

Storm bar 2x4x 1/8"

For units with one single storm bar unless otherwise noted

Height (in)	Storm bar spacing			
	28.5	34.3	44.2	42.0
48.0	- *	120.0	120.0	120**
54.0	- *	120.0	120.0	120**
60.0	- *	120.0	107.7	120**
66.0	- *	116.5	89.0	120**
72.0	119.3	97.9	74.8	105.1**
78.0	101.6	83.4	63.7	89.6**
84.0	87.6	71.9	54.9	77.2**

* UNITS 57" WIDE UP TO 66" HEIGHT DON'T REQUIRE STORM BARS TO ACHIEVE HIGHER DESIGN PRESSURES. REFER TO CHART IN SHEET ONE.

** DESIGN PRESSURES ARE BASED ON TWO STORM BARS PER UNIT.

Design pressure and min. separation Chart
For units w/o storm bars and w/o end retention system

Slat length (in)	Design Pressure (psf)	Deflection (in)	Separation from glass (in)
53.38	120.0	1.603	2.60
64.88	68.6	2.000	3.00
76.00	36.4	2.000	3.00
84.65	23.7	2.000	3.00

REVISIONS			
REV	DESCRIPTION	DATE	APPROVED
A	REVISED NOTE 1	02/02/12	R.L.
B	REVISED PER HVHZ REQUIREMENTS	05/10/12	R.L.
C	REVISED HEIGHT	06/04/12	R.L.

DESIGN PRESSURE CHARTS
FOR UNITS WIDER THAN 88 3/8" WITH TWO OR MORE STORM BARS

Maximum design pressure capacity chart (psf)
Storm bar 2x4x1/8"

Height (in)	Storm Bar spacing (in)
	42.0
48.0	120.0
54.0	120.0
60.0	107.8
66.0	89.1
72.0	74.9
78.0	63.8
84.0	55.0
90.0	47.9
96.0	42.1
102.0	37.3
108.0	33.3
114.0	29.9
120.0	27.0

Maximum design pressure capacity chart (psf)
Storm bar 2x6x1/8"

Height (in)	Storm Bar spacing (in)
	42.0
48.0	120.0
54.0	120.0
60.0	120.0
66.0	120.0
72.0	120.0
78.0	118.1
84.0	101.9
90.0	88.7
96.0	78.0
102.0	69.1
108.0	61.6
114.0	55.3
120.0	49.9

USA SHUTTER COMPANY LLC
1450 RAIL HEAD BLVD
NAPLES, FL 34110

ALUMINUM MAESTROSHIELD
SHUTTER -IN-A-BOX
B.O.M AND DESIGN PRESSURE CHARTS

DRAWN: R.L.	DWG NO. 08-00174	REV C
SCALE NTS	DATE 06/25/07	SHEET 3 OF 10

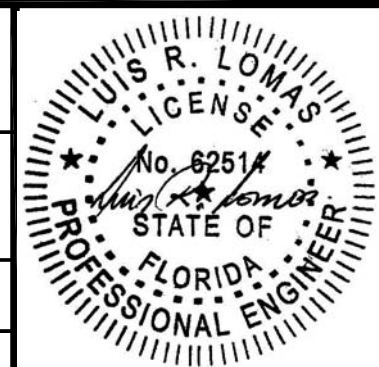

REVISIONS			
REV	DESCRIPTION	DATE	APPROVED
A	REVISED NOTE 1	02/02/12	R.L.
B	REVISED PER HVHZ REQUIREMENTS	05/10/12	R.L.
C	REVISED HEIGHT	06/04/12	R.L.

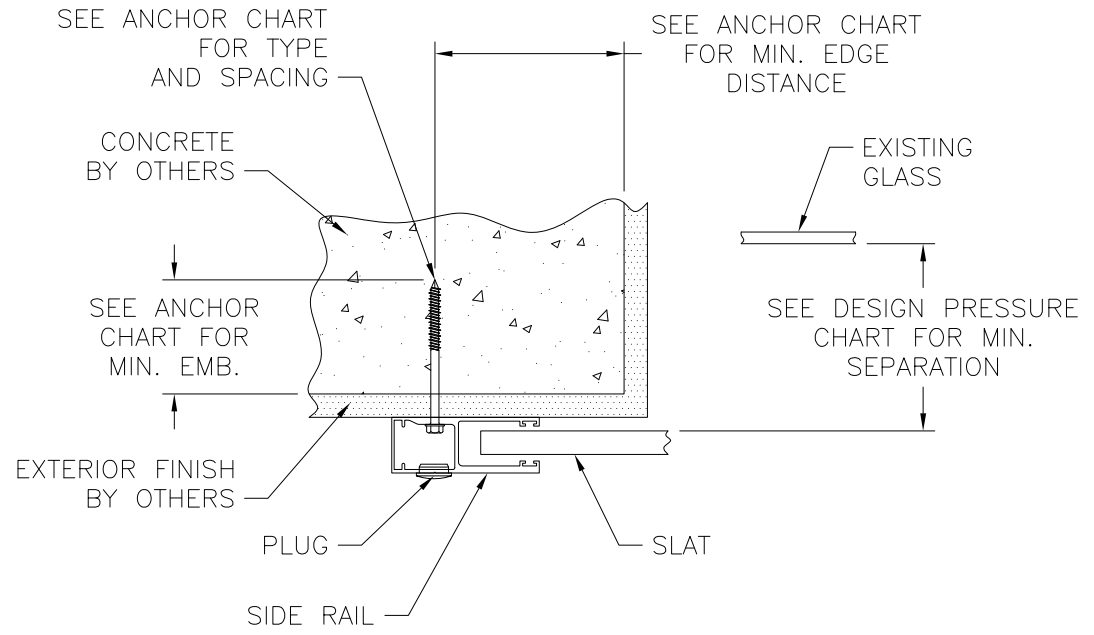

SECTION B-B
 CONCRETE INSTALLATION SHOWN
 SEE CHART SHEETS 7-9 FOR OTHER SUBSTRATES

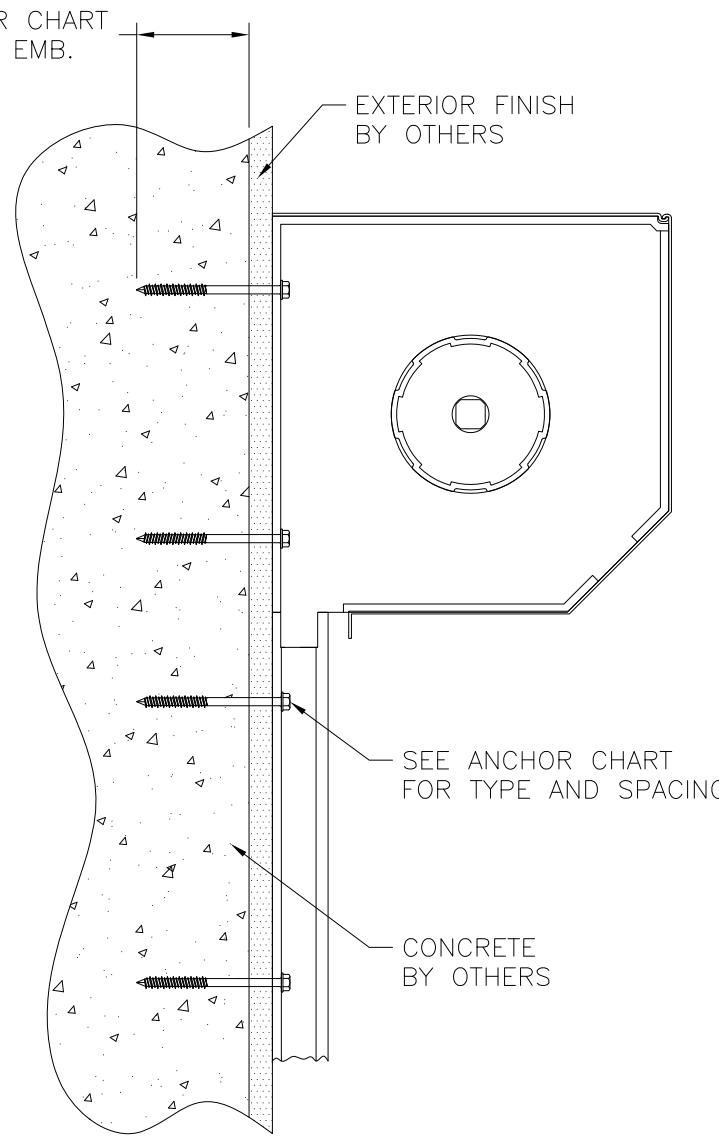

SECTION A-A
 CONCRETE INSTALLATION SHOWN
 SEE CHART SHEETS 7-9 FOR OTHER SUBSTRATES
 SLATS NOT SHOWN FOR CLARITY

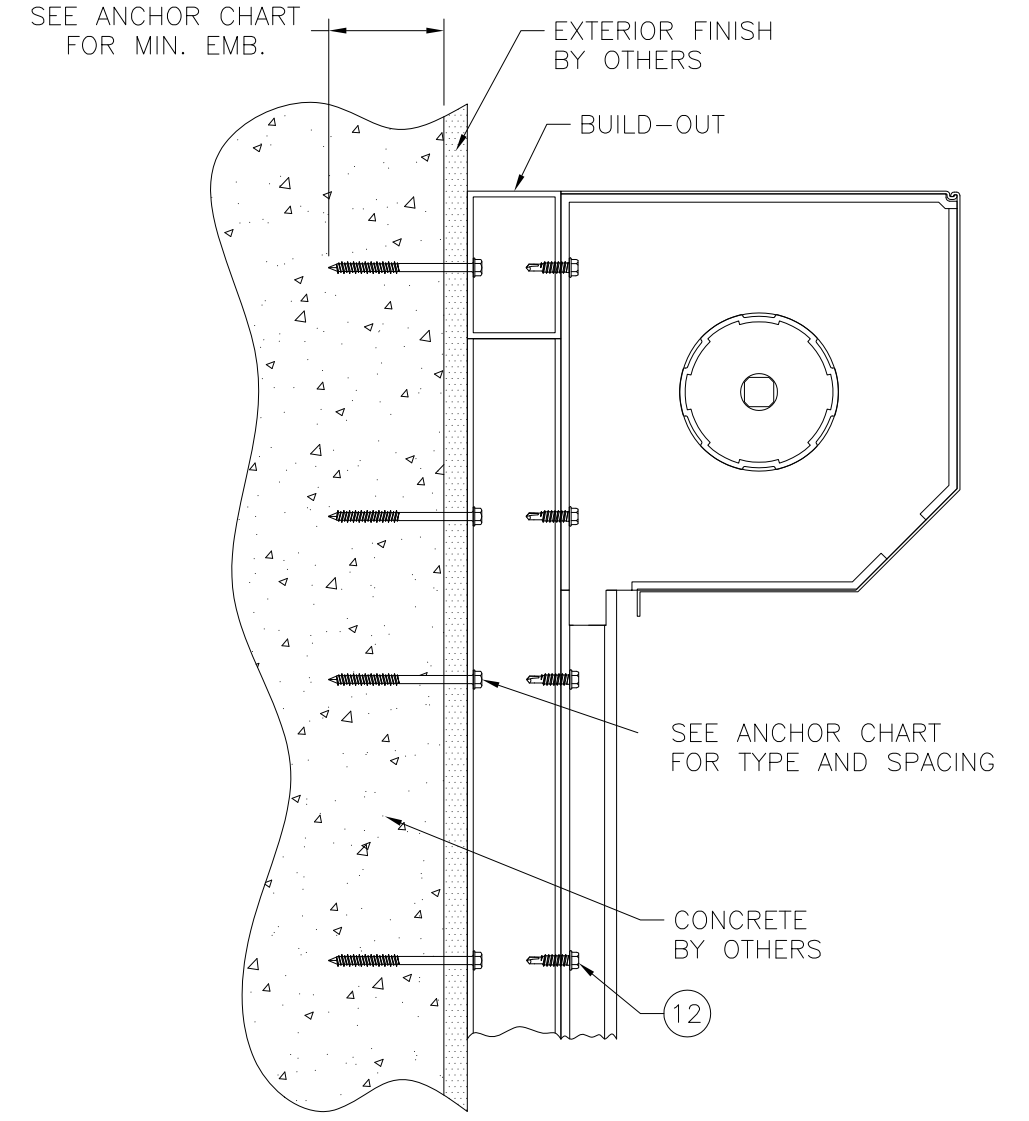

SECTION A-A
 CONCRETE INSTALLATION SHOWN
 SEE CHART SHEETS 7-9 FOR OTHER SUBSTRATES
 SLATS NOT SHOWN FOR CLARITY

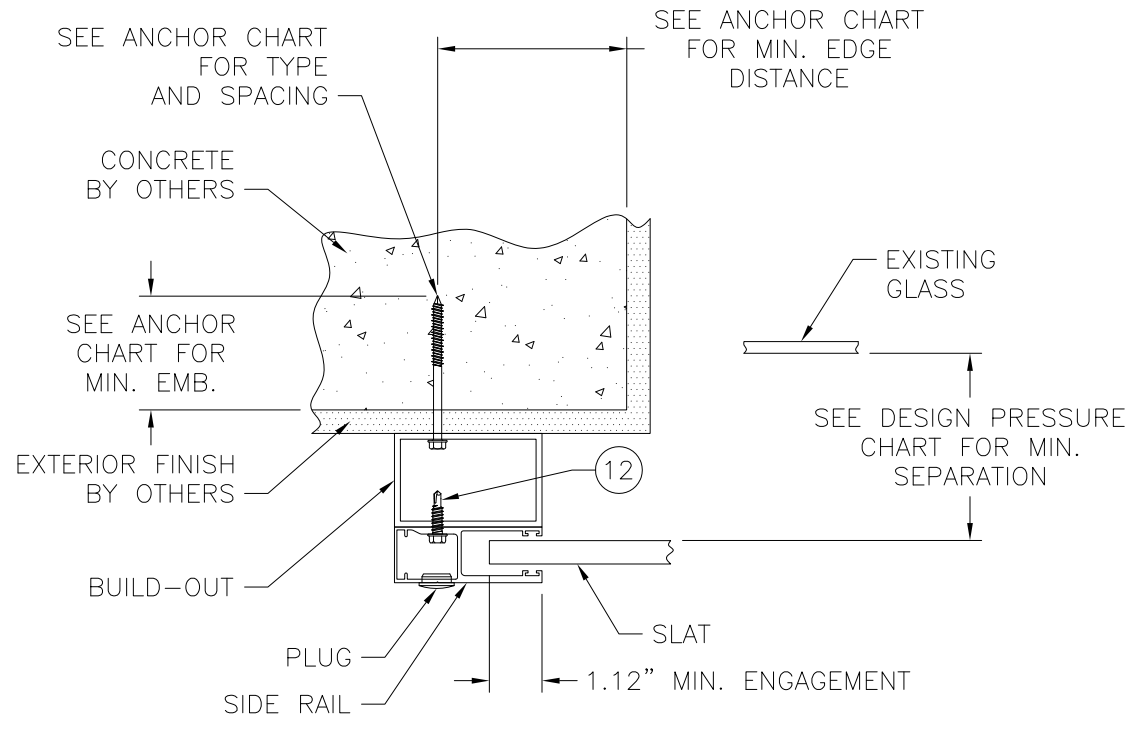

SECTION B-B
 CONCRETE INSTALLATION SHOWN
 SEE CHART SHEETS 7-9 FOR OTHER SUBSTRATES

USA SHUTTER COMPANY LLC
 1450 RAIL HEAD BLVD
 NAPLES, FL 34110

ALUMINUM MAESTROSHIELD
 SHUTTER -IN-A-BOX
 INSTALLATION DETAILS

DRAWN: R.L.	DWG NO. 08-00174	REV C
SCALE NTS	DATE 06/25/07	SHEET 4 OF 10

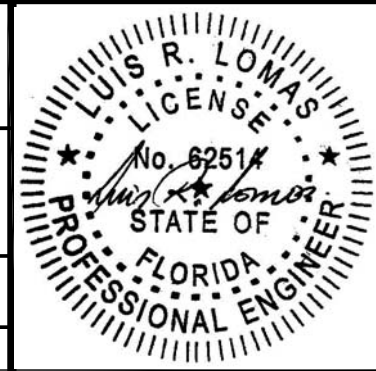

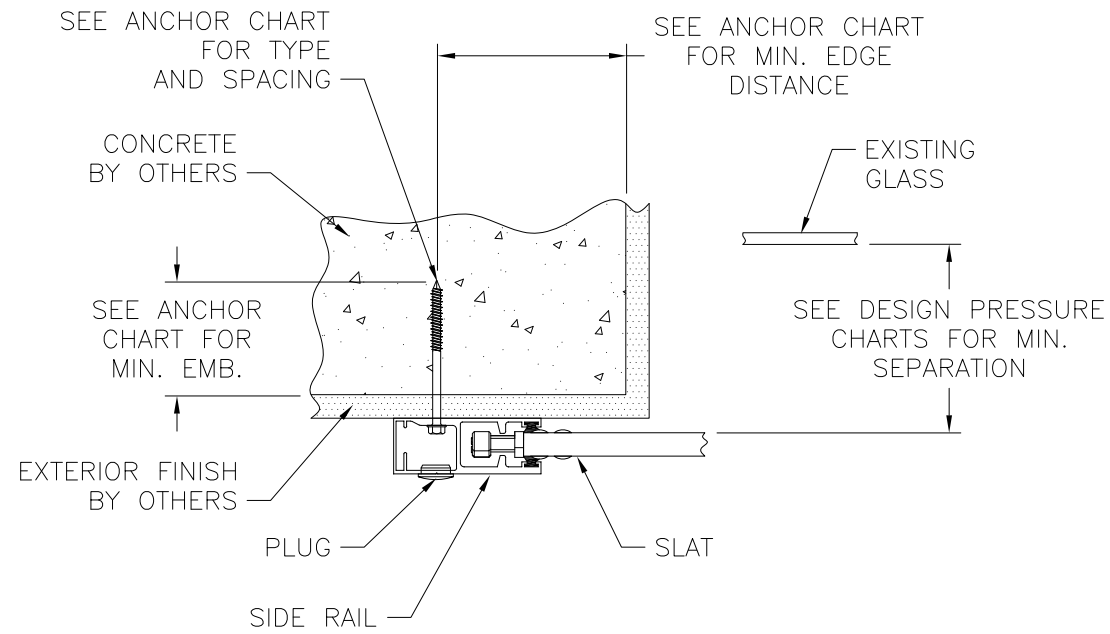

SECTION B-B
 CONCRETE INSTALLATION SHOWN
 SEE CHART SHEETS 7-9 FOR OTHER
 SUBSTRATES

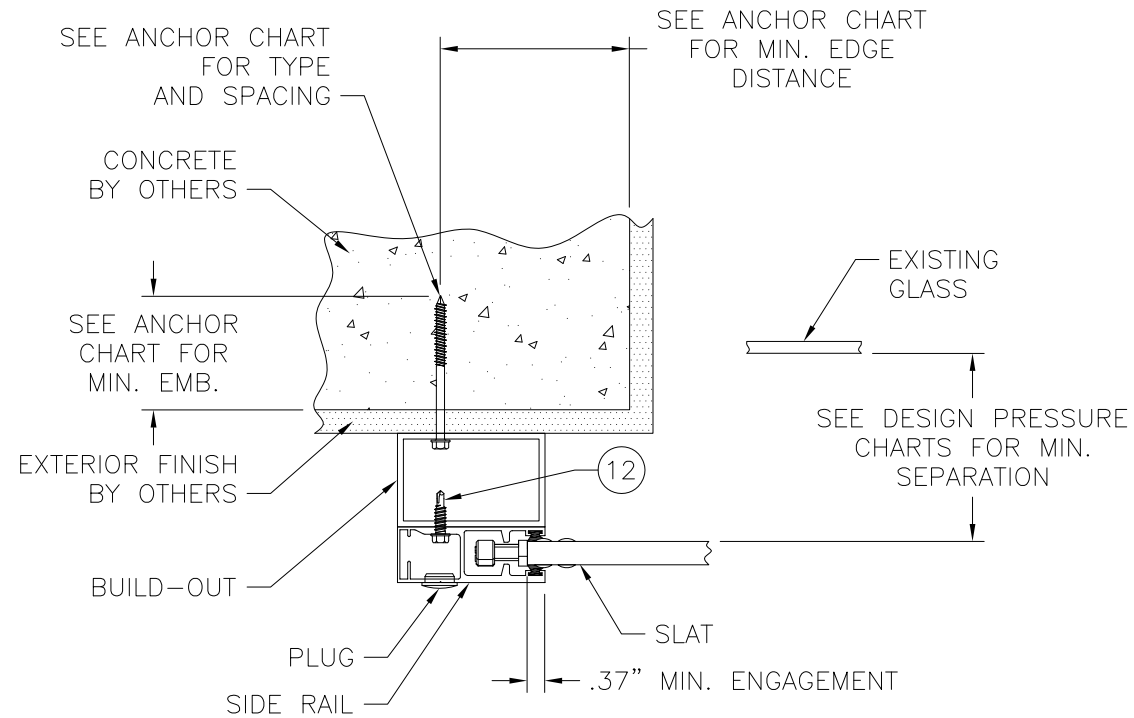

SECTION B-B
 CONCRETE INSTALLATION SHOWN
 SEE CHART SHEETS 7-9 FOR OTHER
 SUBSTRATES

REVISIONS			
REV	DESCRIPTION	DATE	APPROVED
A	REVISED NOTE 1	02/02/12	R.L.
B	REVISED PER HVHZ REQUIREMENTS	05/10/12	R.L.
C	REVISED HEIGHT	06/04/12	R.L.

NOTES:

- 1) END RETENTION IS REQUIRED IN SHUTTERS OF 88 3/16" FINISHED WIDTH WHEN A DESIGN PRESSURE HIGHER THAN 30PSF IS REQUIRED.
- 2) FOR SHUTTERS OF 88 3/16" UP TO 124" FINISHED WIDTH LOCATE END RETENTION AT SIX TOP AND BOTTOM SLATS AND EVERY OTHER SLAT IN BETWEEN.
- 3) FOR SHUTTERS WIDER THAN 124" FINISHED WIDTH LOCATE END RETENTION IN EVERY SLAT.

USA SHUTTER COMPANY LLC 1450 RAIL HEAD BLVD NAPLES, FL 34110		
ALUMINUM MAESTROSHIELD SHUTTER -IN-A-BOX INSTALLATION DETAILS		
DRAWN: R.L.	DWG NO. 08-00174	REV C
SCALE NTS	DATE 06/25/07	SHEET 5 OF 10



Anchor Chart For Slat Lengths Up to 53.375"

For units without Storm Bars

Anchor type	Substrate	Minimum embedment (in)	Minimum edge distance	Max. O.C. (in)	Max. Design pressure	
1/4" Elco Tapcon	Concrete 3,000 psi min.	1.75	2.50	6.00	120	
1/4" ITW Tapcon		1.75	2.50	6.00	120	
1/4" Elco Crete-Flex		1.75	1.75	6.00	120	
1/4" Panelmate Male		1.75	2.50	6.00	120	
1/4" Panelmate Female		1.75	2.50	6.00	120	
1/4" Sleeve anchor		1.13	1.50	6.00	120	
1/4" Powers Calk-in		0.88	3.00	6.00	120	
1/4" Drop-in bolt		1.00	3.50	6.00	120	
1/4" All points solid set		0.88	3.00	6.00	120	
1/4" Elco Tapcon		Hollow block	1.25	2.50	6.00	116
1/4" ITW Tapcon	1.25		2.50	6.00	106	
1/4" Elco Crete-Flex	1.25		2.50	6.00	120	
1/4" Panelmate Male	1.25		2.00	6.00	120	
1/4" Panelmate Female	1.25		2.00	6.00	120	
1/4" Sleeve anchor	1.13		1.50	6.00	120	
1/4" Powers Calk-in	0.88		3.00	6.00	116	
1/4" All points solid set	0.88		3.00	6.00	120	
1/4" Lag screw	Wood .53 min. specific gravity		2.25	N/A	6.00	120
#14 Wood screw			2.00	N/A	6.00	120
1/4" Panelmate Male		0.75	1.88	6.00	120	
1/4" Panelmate Female	0.75	1.88	6.00	120		
1/4-14 Tek Screw	1/8" thick AL	N/A	N/A	6.00	120	

Anchor Chart For Slat Lengths Up to 64.875"

For units without Storm Bars

Anchor type	Substrate	Minimum embedment (in)	Minimum edge distance	Max. O.C. (in)	Max. Design pressure	
1/4" Elco Tapcon	Concrete 3,000 psi min.	1.75	2.50	6.00	55	
1/4" ITW Tapcon		1.75	2.50	6.00	55	
1/4" Elco Crete-Flex		1.75	1.75	6.00	55	
1/4" Panelmate Male		1.75	2.50	6.00	55	
1/4" Panelmate Female		1.75	2.50	6.00	55	
1/4" Sleeve anchor		1.13	1.50	6.00	55	
1/4" Powers Calk-in		0.88	3.00	6.00	55	
1/4" Drop-in bolt		1.00	3.50	6.00	55	
1/4" All points solid set		0.88	3.00	6.00	55	
1/4" Elco Tapcon		Hollow block	1.25	2.50	6.00	55
1/4" ITW Tapcon	1.25		2.50	6.00	55	
1/4" Elco Crete-Flex	1.25		2.50	6.00	55	
1/4" Panelmate Male	1.25		2.00	6.00	55	
1/4" Panelmate Female	1.25		2.00	6.00	55	
1/4" Sleeve anchor	1.13		1.50	6.00	55	
1/4" Powers Calk-in	0.88		3.00	6.00	55	
1/4" All points solid set	0.88		3.00	6.00	55	
1/4" Lag screw	Wood .53 min. specific gravity		2.25	N/A	6.00	55
#14 Wood screw			2.00	N/A	6.00	55
1/4" Panelmate Male		0.75	1.88	6.00	55	
1/4" Panelmate Female	0.75	1.88	6.00	55		
1/4-14 Tek Screw	1/8" thick AL	N/A	N/A	6.00	55	

REVISIONS			
REV	DESCRIPTION	DATE	APPROVED
A	REVISED NOTE 1	02/02/12	R.L.
B	REVISED PER HVHZ REQUIREMENTS	05/10/12	R.L.
C	REVISED HEIGHT	06/04/12	R.L.

Anchor Chart For Slat Lengths Up to 84.65"

For units without Storm Bars

Anchor type	Substrate	Minimum embedment (in)	Minimum edge distance	Max. O.C. (in)	Max. Design pressure	
1/4" Elco Tapcon	Concrete 3,000 psi min.	1.75	2.50	6.00	80	
1/4" ITW Tapcon		1.75	2.50	6.00	80	
1/4" Elco Crete-Flex		1.75	1.75	6.00	80	
1/4" Panelmate Male		1.75	2.50	6.00	80	
1/4" Panelmate Female		1.75	2.50	6.00	80	
1/4" Sleeve anchor		1.13	1.50	6.00	80	
1/4" Powers Calk-in		0.88	3.00	6.00	80	
1/4" Drop-in bolt		1.00	3.50	6.00	80	
1/4" All points solid set		0.88	3.00	6.00	80	
1/4" Elco Tapcon		Hollow block	1.25	2.50	6.00	72
1/4" ITW Tapcon	1.25		2.50	6.00	66	
1/4" Elco Crete-Flex	1.25		2.50	6.00	80	
1/4" Panelmate Male	1.25		2.00	6.00	80	
1/4" Panelmate Female	1.25		2.00	6.00	80	
1/4" Sleeve anchor	1.13		1.50	6.00	80	
1/4" Powers Calk-in	0.88		3.00	6.00	72	
1/4" All points solid set	0.88		3.00	6.00	80	
1/4" Lag screw	Wood .53 min. specific gravity		2.25	N/A	6.00	80
#14 Wood screw			2.00	N/A	6.00	80
1/4" Panelmate Male		0.75	1.88	6.00	80	
1/4" Panelmate Female	0.75	1.88	6.00	80		
1/4-14 Tek Screw	1/8" thick AL	N/A	N/A	6.00	80	

NOTES:

- 1) INSTALL ANCHORS PER MANUFACTURER'S INSTALLATION INSTRUCTIONS.
- 2) MINIMUM EMBEDMENT SHALL BE PER ANCHOR CHART. ANCHORS MINIMUM EMBEDMENT IS BEYOND STUCCO, SHEATHING OR OTHER WALL FINISH.
- 3) TEK SCREWS MUST PENETRATE BEYOND THE ALUMINUM BUILD-OUT A MINIMUM OF THREE PITCH THREADS.
- 4) WOOD FRAMING TO BE .53 MINIMUM SPECIFIC GRAVITY.

USA SHUTTER COMPANY LLC

1450 RAIL HEAD BLVD
NAPLES, FL 34110

ALUMINUM MAESTROSHIELD
SHUTTER -IN-A-BOX
ANCHOR CHARTS

DRAWN: R.L.	DWG NO. 08-00174	REV C
SCALE NTS	DATE 06/25/07	SHEET 6 OF 10

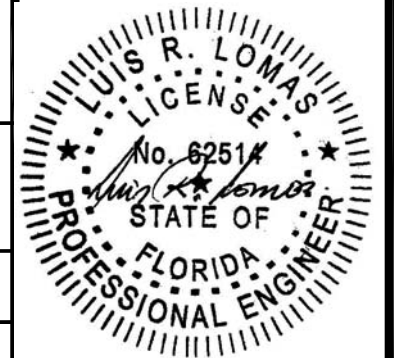

ANCHORING CHART FOR SLAT LENGTHS UP TO 84"
 UNITS WITH ONE STORM BAR AND UNITS WITH STORM BAR SPACING OF 42"

Anchor type	Substrate	Minimum embedment (in)	Minimum edge distance	Max. O.C. (in)	Max. Design pressure	
1/4" Elco Tapcon	Concrete 3,000 psi min.	1.75	2.50	6.00	120	
1/4" ITW Tapcon		1.75	2.50	6.00	120	
1/4" Elco Crete-Flex		1.75	1.75	6.00	120	
1/4" Panelmate Male		1.75	2.50	6.00	120	
1/4" Panelmate Female		1.75	2.50	6.00	120	
1/4" Sleeve anchor		1.13	1.50	6.00	120	
1/4" Powers Calk-in		0.88	3.00	6.00	120	
1/4" Drop-in bolt		1.00	3.50	6.00	101	
1/4" All points solid set		0.88	3.00	6.00	120	
1/4" Elco Tapcon		Hollow block	1.25	2.50	6.00	62
1/4" ITW Tapcon	1.25		2.50	6.00	57	
1/4" Elco Crete-Flex	1.25		2.50	6.00	108	
1/4" Panelmate Male	1.25		2.00	6.00	97	
1/4" Panelmate Female	1.25		2.00	6.00	97	
1/4" Sleeve anchor	1.13		1.50	6.00	99	
1/4" Powers Calk-in	0.88		3.00	6.00	62	
1/4" All points solid set	0.88		3.00	6.00	120	
1/4" Lag screw	Wood .53 min. specific gravity		2.25	N/A	6.00	120
#14 Wood screw			2.00	N/A	6.00	120
1/4" Panelmate Male		0.75	1.88	6.00	120	
1/4" Panelmate Female		0.75	1.88	6.00	120	
1/4-14 Tek Screw	1/8" thick AL	N/A	N/A	6.00	120	

ANCHORING CHART FOR SLAT LENGTHS UP TO 84"
 UNITS WITH TWO STORM BARS

Anchor type	Substrate	Minimum embedment (in)	Minimum edge distance	Max. O.C. (in)	Max. Design pressure	
1/4" Elco Tapcon	Concrete 3,000 psi min.	1.75	2.50	6.00	120	
1/4" ITW Tapcon		1.75	2.50	6.00	120	
1/4" Elco Crete-Flex		1.75	1.75	6.00	120	
1/4" Panelmate Male		1.75	2.50	6.00	120	
1/4" Panelmate Female		1.75	2.50	6.00	120	
1/4" Sleeve anchor		1.13	1.50	6.00	120	
1/4" Powers Calk-in		0.88	3.00	6.00	120	
1/4" Drop-in bolt		1.00	3.50	6.00	120	
1/4" All points solid set		0.88	3.00	6.00	120	
1/4" Elco Tapcon		Hollow block	1.25	2.50	6.00	120
1/4" ITW Tapcon	1.25		2.50	6.00	110	
1/4" Elco Crete-Flex	1.25		2.50	6.00	120	
1/4" Panelmate Male	1.25		2.00	6.00	120	
1/4" Panelmate Female	1.25		2.00	6.00	120	
1/4" Sleeve anchor	1.13		1.50	6.00	120	
1/4" Powers Calk-in	0.88		3.00	6.00	120	
1/4" All points solid set	0.88		3.00	6.00	120	
1/4" Lag screw	Wood .53 min. specific gravity		2.25	N/A	6.00	120
#14 Wood screw			2.00	N/A	6.00	120
1/4" Panelmate Male		0.75	1.88	6.00	120	
1/4" Panelmate Female		0.75	1.88	6.00	120	
1/4-14 Tek Screw	1/8" thick AL	N/A	N/A	6.00	120	

REVISIONS			
REV	DESCRIPTION	DATE	APPROVED
A	REVISED NOTE 1	02/02/12	R.L.
B	REVISED PER HVHZ REQUIREMENTS	05/10/12	R.L.
C	REVISED HEIGHT	06/04/12	R.L.

ANCHORING CHART FOR SLAT LENGTHS UP TO 64.88"
 UNITS WITH ONE STORM BAR

Anchor type	Substrate	Minimum embedment (in)	Minimum edge distance	Max. O.C. (in)	Max. Design pressure	
1/4" Elco Tapcon	Concrete 3,000 psi min.	1.75	2.50	6.00	120	
1/4" ITW Tapcon		1.75	2.50	6.00	120	
1/4" Elco Crete-Flex		1.75	1.75	6.00	120	
1/4" Panelmate Male		1.75	2.50	6.00	120	
1/4" Panelmate Female		1.75	2.50	6.00	120	
1/4" Sleeve anchor		1.13	1.50	6.00	120	
1/4" Powers Calk-in		0.88	3.00	6.00	120	
1/4" Drop-in bolt		1.00	3.50	6.00	120	
1/4" All points solid set		0.88	3.00	6.00	120	
1/4" Elco Tapcon		Hollow block	1.25	2.50	6.00	81
1/4" ITW Tapcon	1.25		2.50	6.00	74	
1/4" Elco Crete-Flex	1.25		2.50	6.00	120	
1/4" Panelmate Male	1.25		2.00	6.00	120	
1/4" Panelmate Female	1.25		2.00	6.00	120	
1/4" Sleeve anchor	1.13		1.50	6.00	120	
1/4" Powers Calk-in	0.88		3.00	6.00	81	
1/4" All points solid set	0.88		3.00	6.00	120	
1/4" Lag screw	Wood .53 min. specific gravity		2.25	N/A	6.00	120
#14 Wood screw			2.00	N/A	6.00	120
1/4" Panelmate Male		0.75	1.88	6.00	120	
1/4" Panelmate Female		0.75	1.88	6.00	120	
1/4-14 Tek Screw	1/8" thick AL	N/A	N/A	6.00	120	

ANCHORING CHART FOR SLAT LENGTHS UP TO 53.38"
 UNITS WITH ONE STORM BAR

Anchor type	Substrate	Minimum embedment (in)	Minimum edge distance	Max. O.C. (in)	Max. Design pressure	
1/4" Elco Tapcon	Concrete 3,000 psi min.	1.75	2.50	6.00	120	
1/4" ITW Tapcon		1.75	2.50	6.00	120	
1/4" Elco Crete-Flex		1.75	1.75	6.00	120	
1/4" Panelmate Male		1.75	2.50	6.00	120	
1/4" Panelmate Female		1.75	2.50	6.00	120	
1/4" Sleeve anchor		1.13	1.50	6.00	120	
1/4" Powers Calk-in		0.88	3.00	6.00	120	
1/4" Drop-in bolt		1.00	3.50	6.00	120	
1/4" All points solid set		0.88	3.00	6.00	120	
1/4" Elco Tapcon		Hollow block	1.25	2.50	6.00	97
1/4" ITW Tapcon	1.25		2.50	6.00	89	
1/4" Elco Crete-Flex	1.25		2.50	6.00	120	
1/4" Panelmate Male	1.25		2.00	6.00	120	
1/4" Panelmate Female	1.25		2.00	6.00	120	
1/4" Sleeve anchor	1.13		1.50	6.00	120	
1/4" Powers Calk-in	0.88		3.00	6.00	97	
1/4" All points solid set	0.88		3.00	6.00	120	
1/4" Lag screw	Wood .53 min. specific gravity		2.25	N/A	6.00	120
#14 Wood screw			2.00	N/A	6.00	120
1/4" Panelmate Male		0.75	1.88	6.00	120	
1/4" Panelmate Female		0.75	1.88	6.00	120	
1/4-14 Tek Screw	1/8" thick AL	N/A	N/A	6.00	120	

NOTES:

- 1) INSTALL ANCHORS PER MANUFACTURER'S INSTALLATION INSTRUCTIONS.
- 2) MINIMUM EMBEDMENT SHALL BE PER ANCHOR CHART. ANCHORS MINIMUM EMBEDMENT IS BEYOND STUCCO, SHEATHING OR OTHER WALL FINISH.
- 3) TEK SCREWS MUST PENETRATE BEYOND THE ALUMINUM BUILD-OUT A MINIMUM OF THREE PITCH THREADS.
- 4) WOOD FRAMING TO BE .53 MINIMUM SPECIFIC GRAVITY.

USA SHUTTER COMPANY LLC
 1450 RAIL HEAD BLVD
 NAPLES, FL 34110

ALUMINUM MAESTROSHIELD
 SHUTTER -IN-A-BOX
 ANCHOR CHARTS

DRAWN: R.L.	DWG NO. 08-00174	REV C
SCALE NTS	DATE 06/25/07	SHEET 7 OF 10

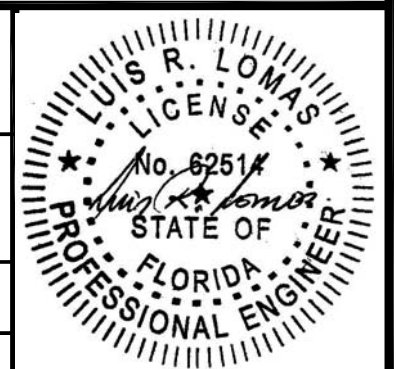

REVISIONS			
REV	DESCRIPTION	DATE	APPROVED
A	REVISED NOTE 1	02/02/12	R.L.
B	REVISED PER HVHZ REQUIREMENTS	05/10/12	R.L.
C	REVISED HEIGHT	06/04/12	R.L.

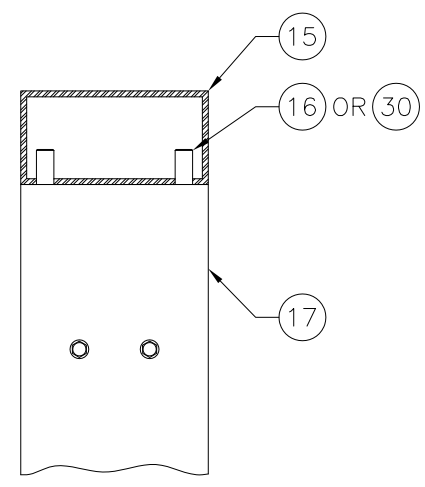

SECTION C-C
 STORM BAR INSTALLATION TOP SIDE
 FOR INSTALLING SPRING BLOCK TO STORM BAR
 SEE DETAIL F
 FOR UNITS 88 3/8" WIDE AND SMALLER

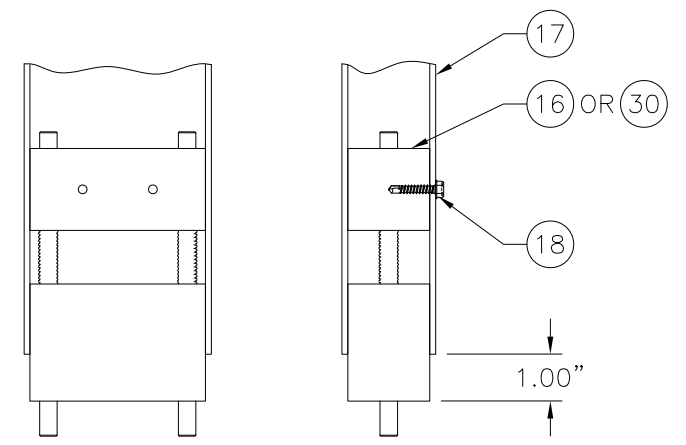

DETAIL F
 SPRING BLOCK ASSY INSTALLATION TO STORM BAR

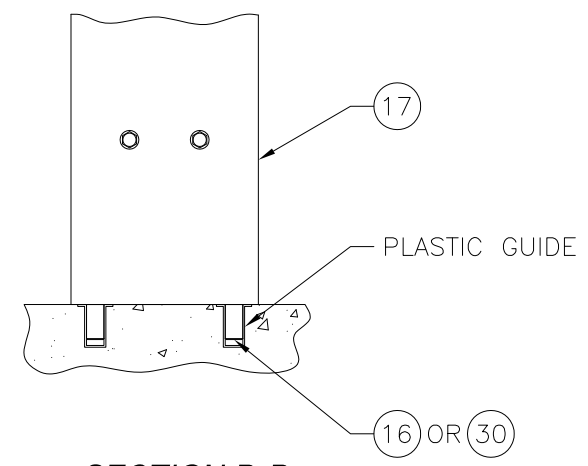

SECTION D-D
 STORM BAR INSTALLATION BOTTOM SIDE
 FOR INSTALLING SPRING BLOCK TO STORM BAR
 SEE DETAIL F

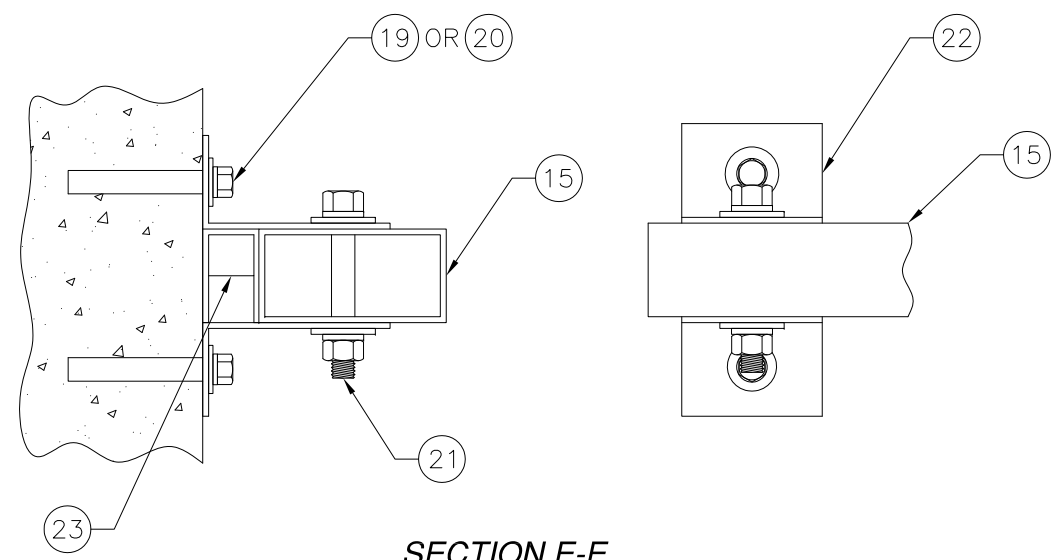

SECTION E-E
 HEADER INSTALLATION
 FOR UNITS 88 3/8" WIDE AND SMALLER

USA SHUTTER COMPANY LLC 1450 RAIL HEAD BLVD NAPLES, FL 34110		
ALUMINUM MAESTROSHIELD SHUTTER -IN-A-BOX ANCHOR CHARTS		
DRAWN: R.L.	DWG NO. 08-00174	REV C
SCALE NTS	DATE 06/25/07	SHEET 8 OF 10

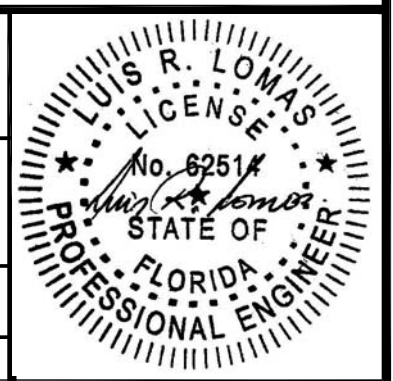

REVISIONS			
REV	DESCRIPTION	DATE	APPROVED
A	REVISED NOTE 1	02/02/12	R.L.
B	REVISED PER HVHZ REQUIREMENTS	05/10/12	R.L.
C	REVISED HEIGHT	06/04/12	R.L.

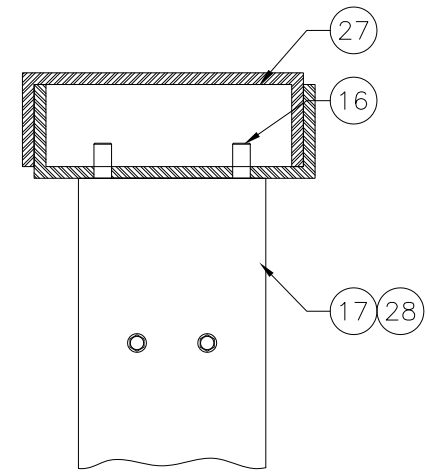

SECTION C-C
STORM BAR INSTALLATION TOP SIDE
FOR INSTALLING SPRING BLOCK TO STORM BAR
SEE DETAIL F
FOR UNITS 262 3/4" WIDE AND SMALLER

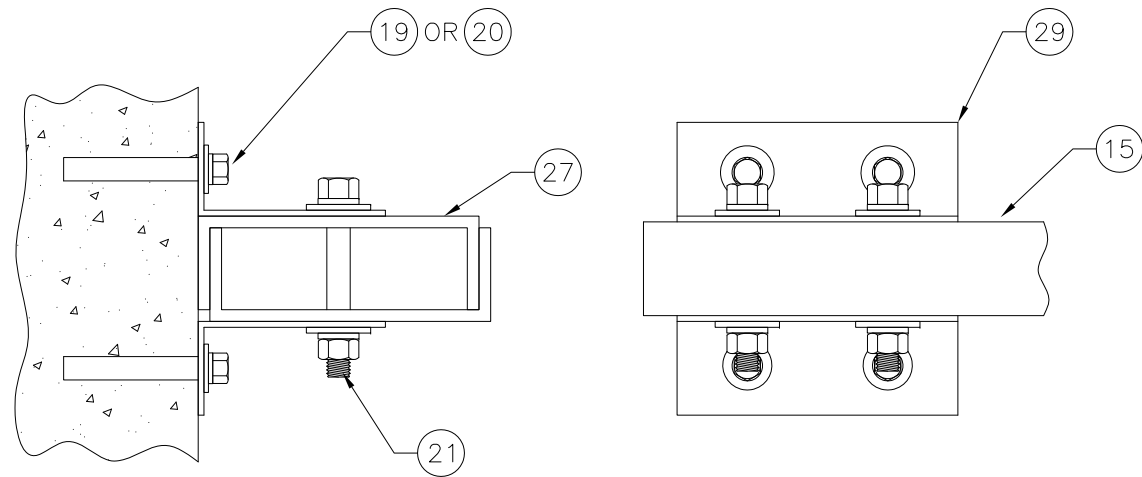

SECTION E-E
HEADER INSTALLATION
FOR UNITS 262 3/4" WIDE AND SMALLER

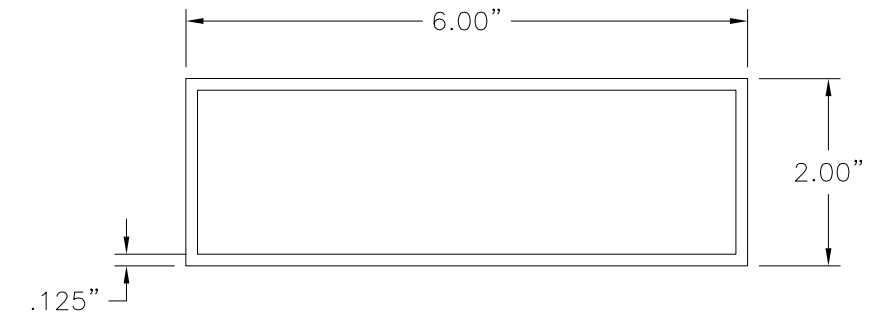

(28) **STORM BAR**
6063-T5 ALUMINUM

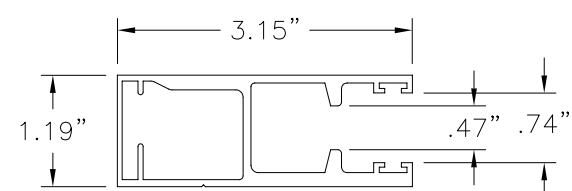

(31) **SIDE RAIL FOR END RETENTION**
6063-T5 ALUMINUM

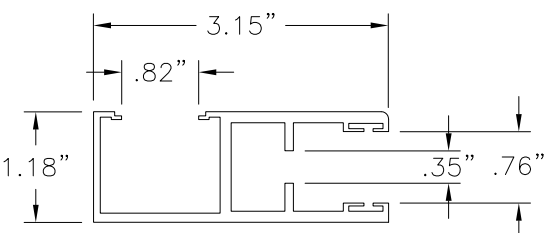

(26) **SIDE RAIL FOR END RETENTION (OPTIONAL)**
6063-T5 ALUMINUM

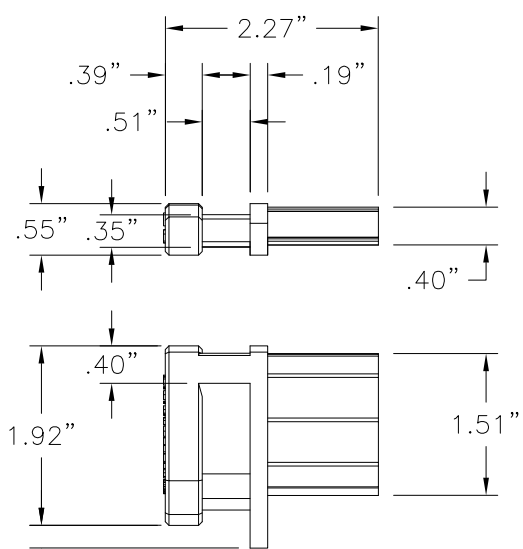

(24) **END RETENTION - RIGHT**
NYLON

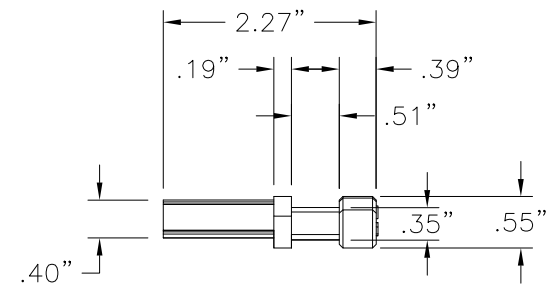

(25) **END RETENTION - LEFT**
NYLON

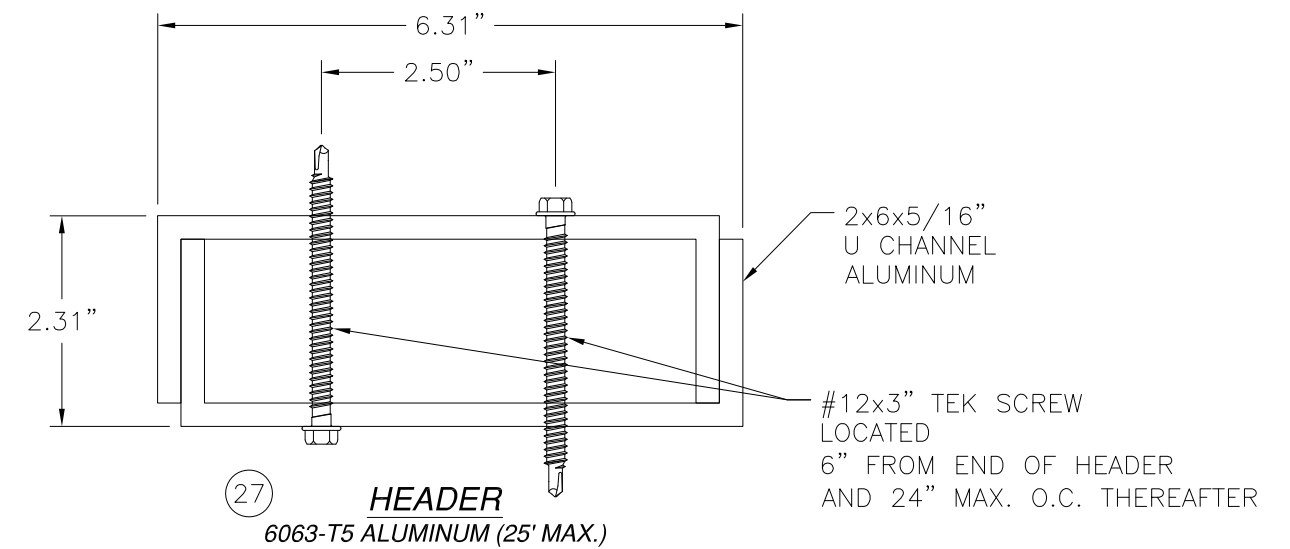

(27) **HEADER**
6063-T5 ALUMINUM (25' MAX.)

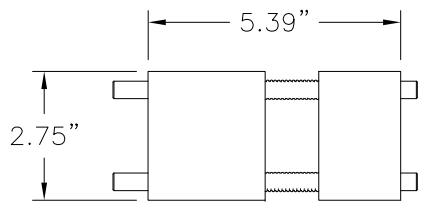

(30) **2X3 SPRING BLOCK**

USA SHUTTER COMPANY LLC
1450 RAIL HEAD BLVD
NAPLES, FL 34110

ALUMINUM MAESTROSHIELD
SHUTTER -IN-A-BOX
INSTALLATION DETAILS

DRAWN: R.L.	DWG NO. 08-00174	REV C
SCALE NTS	DATE 06/25/07	SHEET 9 OF 10

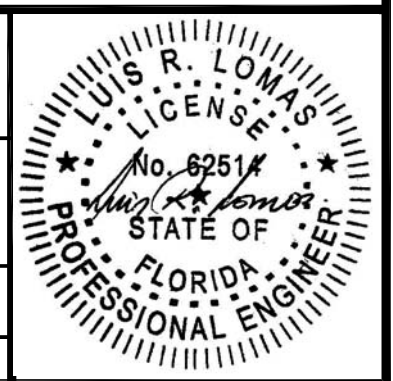

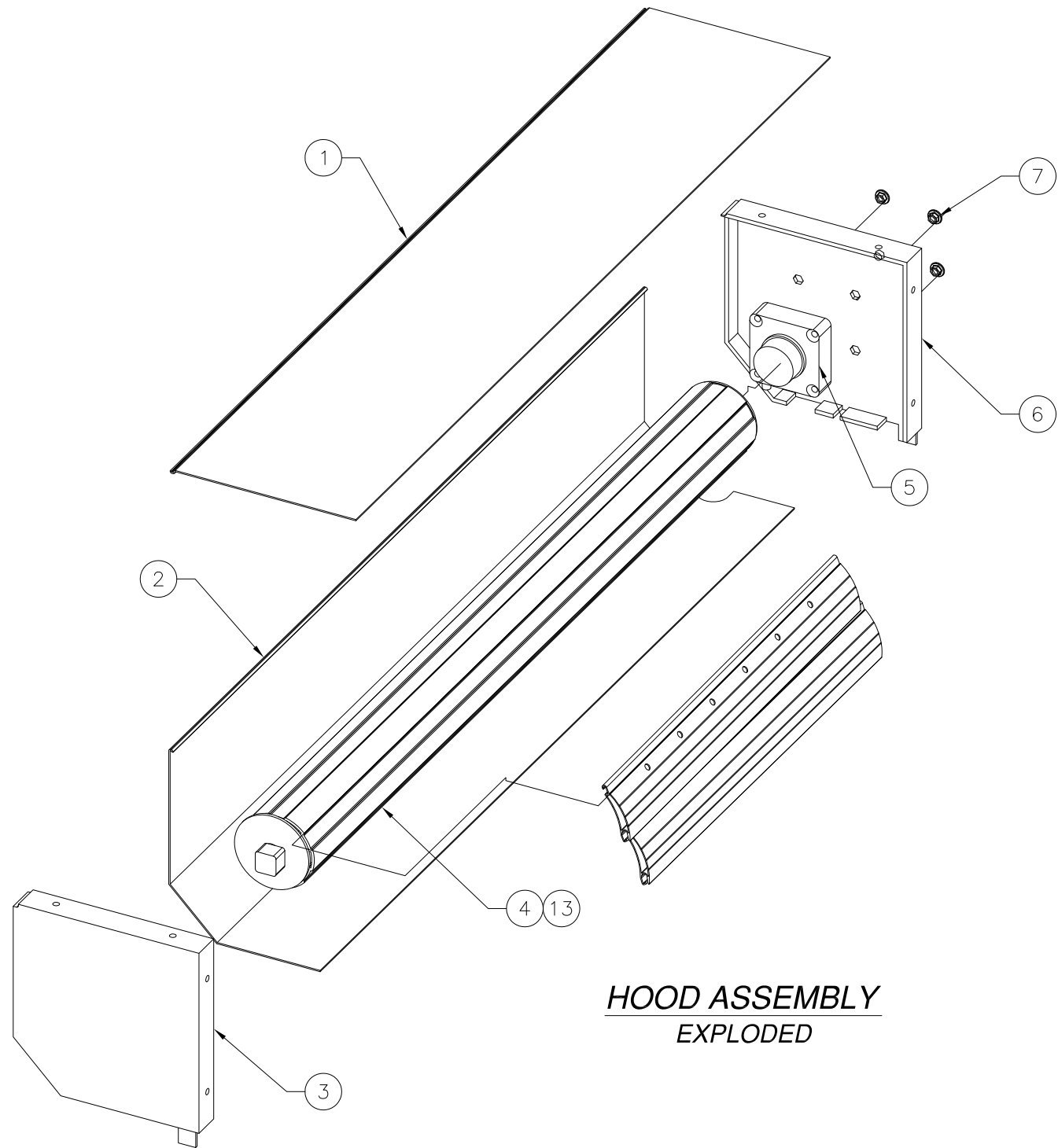

**HOOD ASSEMBLY
EXPLODED**

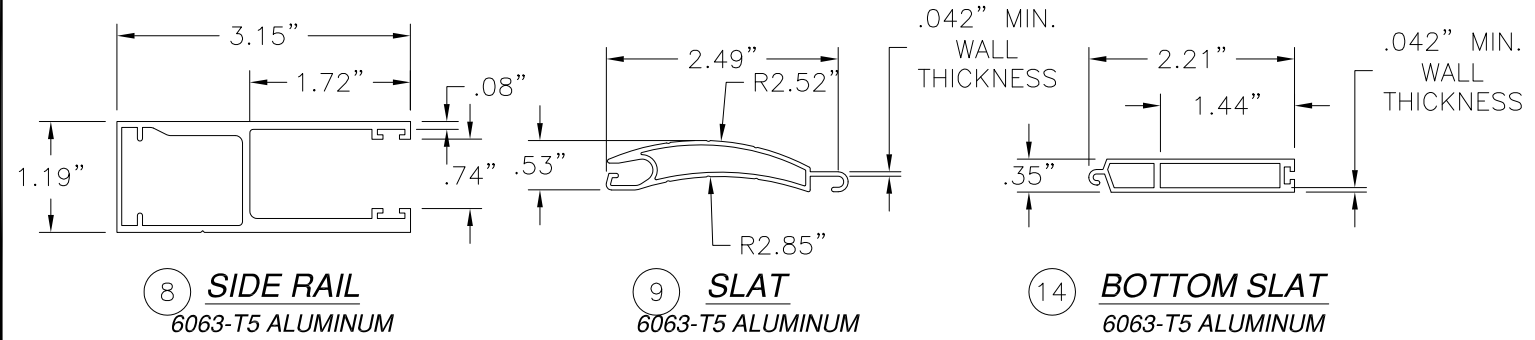

**8 SIDE RAIL
6063-T5 ALUMINUM**

**9 SLAT
6063-T5 ALUMINUM**

**14 BOTTOM SLAT
6063-T5 ALUMINUM**

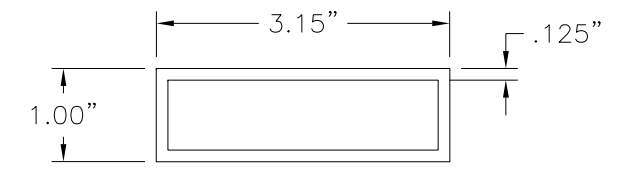

**10 STANDARD BUILD-OUT
6063-T5 ALUMINUM**

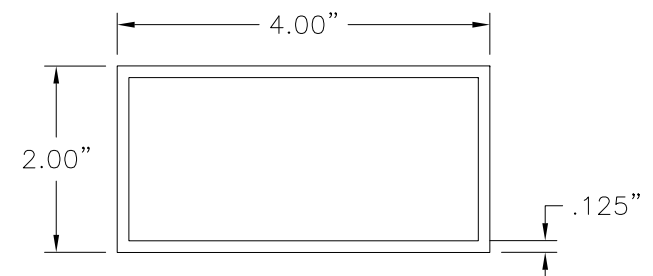

**15 HEADER
6063-T5 ALUMINUM**

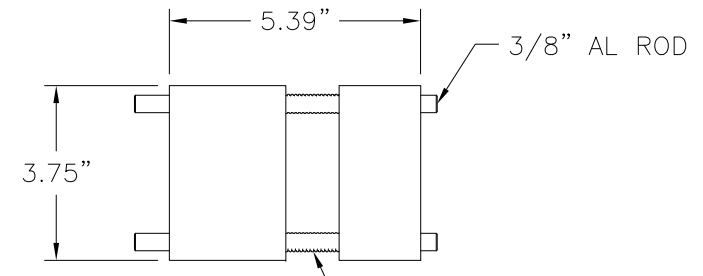

16 2x4 SPRING BLOCK ASSY

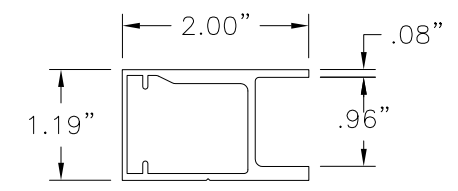

**23 SPACER
6063-T5 ALUMINUM
TRIM FROM SIDE RAIL**

REVISIONS			
REV	DESCRIPTION	DATE	APPROVED
A	REVISED NOTE 1	02/02/12	R.L.
B	REVISED PER HVHZ REQUIREMENTS	05/10/12	R.L.
C	REVISED HEIGHT	06/04/12	R.L.

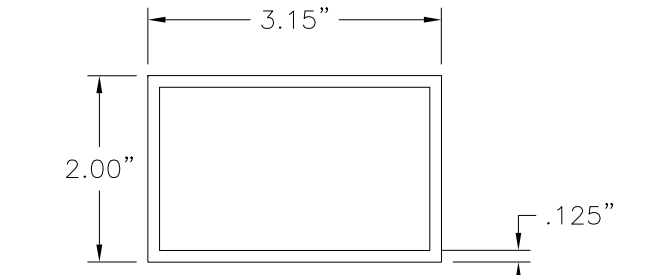

**11 OPTIONAL BUILDOUT
6063-T5 ALUMINUM**

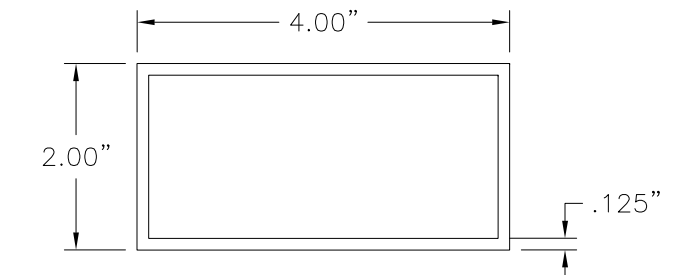

**17 STORM BAR
6063-T5 ALUMINUM**

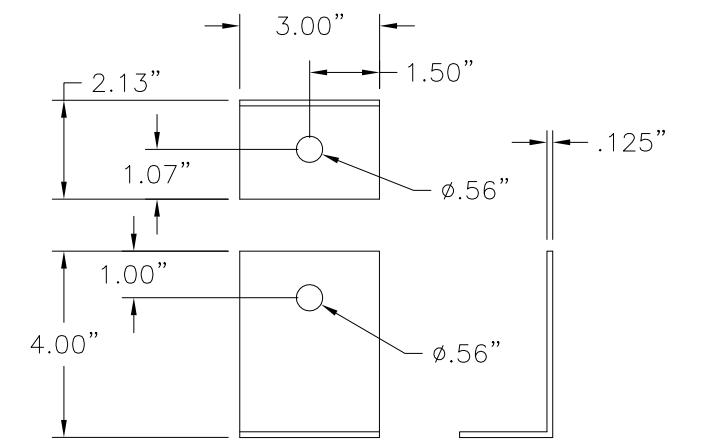

**22 MOUNTING ANGLE
6063-T5 ALUMINUM**

USA SHUTTER COMPANY LLC
1450 RAIL HEAD BLVD
NAPLES, FL 34110

ALUMINUM MAESTROSHIELD
SHUTTER -IN-A-BOX
COMPONENTS

DRAWN: R.L.	DWG. NO. 08-00174	REV C
SCALE NTS	DATE 06/25/07	SHEET 10 OF 10

