



EXTERIOR RESEARCH & DESIGN, LLC.
 Certificate of Authorization #9503
 353 CHRISTIAN STREET, UNIT #13
 OXFORD, CT 06478
 PHONE: (203) 262-9245
 FAX: (203) 262-9243

EVALUATION REPORT

Entegra Roof Tile, Inc.
 1289 NE 9th Avenue
 Okeechobee, FL 34972

Evaluation Report E39310.11.11-2
FL7804-R5
Date of Issuance: 11/02/2011

SCOPE:

This Evaluation Report is issued under Rule 9N-3 and the applicable rules and regulations governing the use of construction materials in the State of Florida. The documentation submitted has been reviewed by Robert Nieminen, P.E. for use of the product under the Florida Building Code and Florida Building Code, Residential Volume. The products described herein have been designed to comply with the 2007 and 2010 Florida Building Code (non-HVHZ) sections noted herein.

DESCRIPTION: Entegra Concrete Roof Tiles (non-HVHZ jurisdictions)

LABELING: Each unit shall bear labeling in accordance with the requirements the Accredited Quality Assurance Agency noted herein.

CONTINUED COMPLIANCE: This Evaluation Report is valid until such time as the named product(s) changes, the referenced Quality Assurance documentation changes, or provisions of the Code that relate to the product change. Acceptance of this Evaluation Report by the named client constitutes agreement to notify Robert Nieminen, P.E. if the product changes or the referenced Quality Assurance documentation changes. Trinity|ERD requires a complete review of this Evaluation Report relative to updated Code requirements with each Code Cycle.

ADVERTISEMENT: The Evaluation Report number preceded by the words "Trinity|ERD Evaluated" may be displayed in advertising literature. If any portion of the Evaluation Report is displayed, then it shall be done in its entirety.

INSPECTION: Upon request, a copy of this entire Evaluation Report shall be provided to the user by the manufacturer or its distributors and shall be available for inspection at the job site at the request of the Building Official.

This Evaluation Report consists of pages 1 through 4.

Prepared by:

Robert J.M. Nieminen, P.E.
 Florida Registration No. 59166, Florida DCA ANE1983

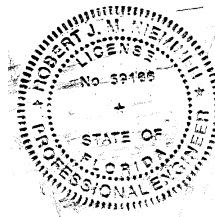

The facsimile seal appearing was authorized by Robert Nieminen, P.E. on 11/02/2011. This does not serve as an electronically signed document. Signed, sealed hardcopies have been transmitted to the Product Approval Administrator and to the named client.

CERTIFICATION OF INDEPENDENCE:

1. Trinity|ERD does not have, nor does it intend to acquire or will it acquire, a financial interest in any company manufacturing or distributing products it evaluates.
2. Trinity|ERD is not owned, operated or controlled by any company manufacturing or distributing products it evaluates.
3. Robert Nieminen, P.E. does not have nor will acquire, a financial interest in any company manufacturing or distributing products for which the evaluation reports are being issued.
4. Robert Nieminen, P.E. does not have, nor will acquire, a financial interest in any other entity involved in the approval process of the product.

ROOFING SYSTEM EVALUATION:

1. SCOPE:

Product Category: Roofing

Sub-Category: Roofing Tiles

Compliance Statement: Entegra Concrete Roof Tiles, as produced by Entegra Roof Tile, Inc., have demonstrated compliance with the following sections of the Florida Building Code through testing in accordance with the following Standards. Compliance is subject to the Installation Requirements and Limitations / Conditions of Use set forth herein.

2. STANDARDS:

<u>Code</u>	<u>Section</u>	<u>Property</u>	<u>Standard</u>	<u>Year</u>
2007 & 2010	1507.3.5	Physical Properties	ASTM C1492	2003
2007 & 2010	1507.3.7	Attachment Requirements	FRSA/TRI 07320/8	2005
2007	1715.2.1	Overtopping Moment	SSTD 11	1997
2010	1716.2.1	Overtopping Moment	SSTD 11	1997

3. REFERENCES:

<u>Entity</u>	<u>Examination</u>	<u>Reference</u>	<u>Date</u>
ATL (TST3782)	ASTM C1492	RT0615.01-11	06/28/2011
ATL (TST3782)	ASTM C1492	RT0615.02-11	06/28/2011
ATL (TST3782)	ASTM C1492	RT0615.03-11	06/28/2011
ATL (TST3782)	ASTM C1492	RT0615.04-11	06/28/2011
ATL (TST3782)	ASTM C1492	RT0615.05-11	06/28/2011
Tile Roof Institute	SSTD 11	Membership Confirmation	Current
PRI (QUA9110)	Quality Assurance	Service Confirmation	11/02/2011

4. PRODUCT DESCRIPTION:

4.1 **BERMUDA FLAT and PLANTATION FLAT** are ASTM C1492, Type III (low-profile) concrete roof tiles.

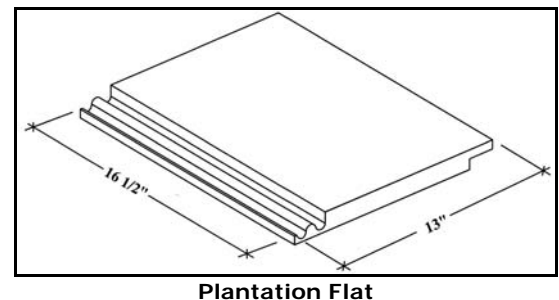
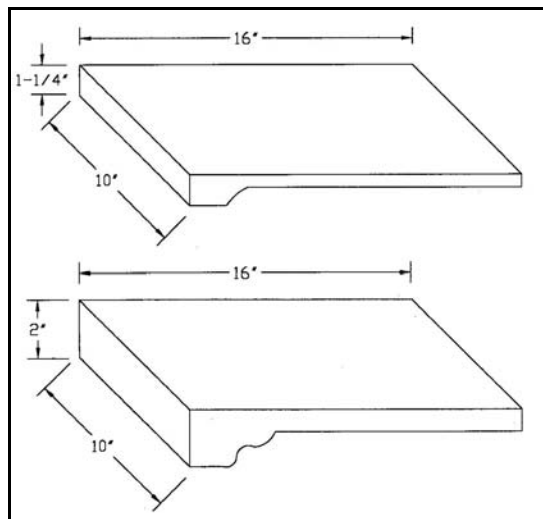

4.2 **BELLA HIGH "S"** and **ESTATE "S"** are ASTM D1492, Type II (medium-profile) concrete roof tiles.

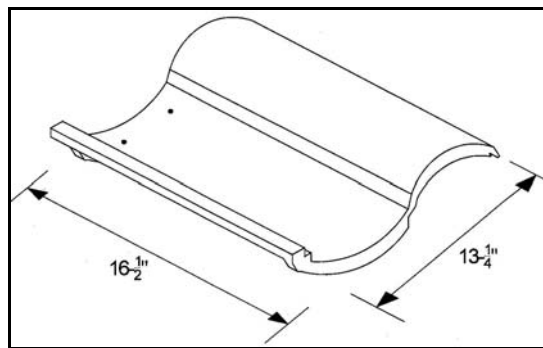

Bella High "S"

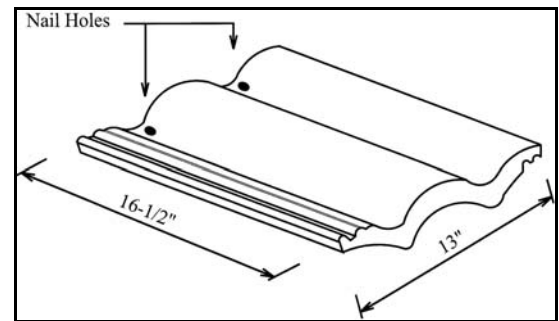

Estate "S"

4.3 **GALENA SPANISH "S"** are ASTM C1492, Type I (high-profile) concrete roof tiles.

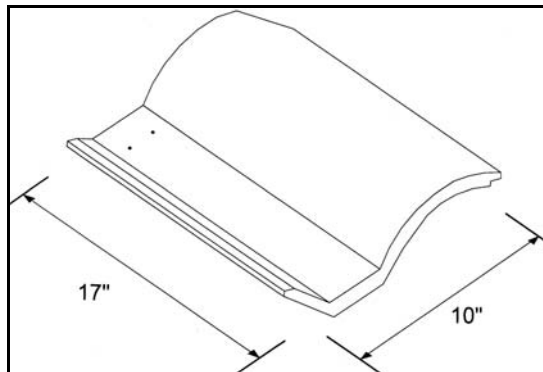

5. LIMITATIONS:

- 5.1 This Evaluation Report is not for use in the HVHZ.
- 5.2 Fire classification is not part of this evaluation; refer to FBC Section 1505 and current Approved Roofing Materials Directory for fire rating of this product.
- 5.3 Installation shall comply with manufacturer's current published instructions, but not less than the requirements of FBC Section 1507.3 and the FRSA/TRI 07320.
- 5.4 For mechanically attached tiles, attachment for wind load resistance shall be in accordance with FRSA/TRI 07320/8-05.
- 5.5 For mortar-set or adhesive-set tiles, attachment for wind load resistance shall be in accordance with FBC Section 1609.5.3 and the mortar or adhesive manufacturer's Product Approval.
- 5.6 All products in the roof assembly shall have quality assurance audit in accordance with the Florida Building Code and F.A.C. Rule 9N-3.
- 5.7 This Evaluation Report is limited to use on projects in areas subjected to weathering indices of 50 or less (negligible weathering), as outlined in Figure 1 of ASTM C1492-03¹, reproduced below for reference.

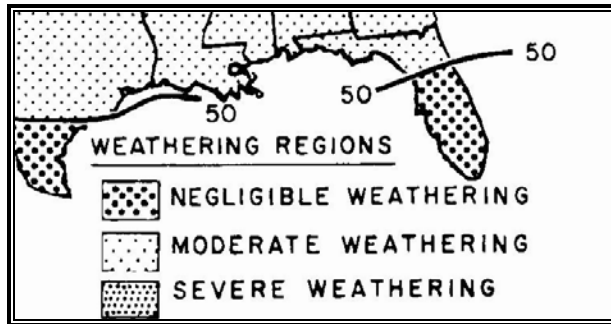

6. INSTALLATION:

6.1 Entegra Concrete Roof Tiles may be mechanically fastened, mortar-set or adhesive-set. Installation shall comply with manufacturer’s current published instructions, but not less than the requirements of FBC Section 1507.3, the FRSA/TRI 07320 and, for mortar-set or adhesive-set applications, the mortar or adhesive manufacturer’s Product Approval.

7. LABELING:

7.1 Each unit shall bear the imprint or identifiable marking of the manufacturer’s name or logo. Tile lots shall be labeled in accordance with the requirements of the Accredited Quality Assurance Agency noted herein.

7.2 Tile not tested for freeze-thaw shall state clearly that the lot has not been tested for freeze-thaw acceptance on all lot tags or certification.

8. BUILDING PERMIT REQUIREMENTS:

As required by the Building Official or Authority Having Jurisdiction in order to properly evaluate the installation of this product.

9. MANUFACTURING PLANTS:

Contact the noted QA agency for information on product locations covered for F.A.C. Rule 9N-3 QA requirements.

10. QUALITY ASSURANCE ENTITY:

PRI Construction Materials Technologies, LLC. – QUA9110; (813) 621-5777

- END OF EVALUATION REPORT -

¹ ASTM C1492-03, Standard Specification for Concrete Roof Tile, © ASTM International