

INTRODUCING THE



HURRICANE NETTING SYSTEM

INSTALLATION & USE GUIDELINES

NON-IMPACT
WIND ABATEMENT
COVERING / HOLDDOWN PROTECTION VERSION

WWW.HURRICANE-NET.COM

1-877-CAT5-INC

EMAIL: INFO@HURRICANE-NET.COM

COPYRIGHT © 2006 CAT-5 PROTECTION, INC.
PATENT PENDING

Product Uses

The CAT-5 Hurricane Netting System helps deflect and slow wind, while letting air 'breathe' in a structure before, during, and after a storm, allowing light to still pass through and provide usable areas during times of power outages. Effective use of the net will also keep covered contents in place and from becoming flying debris.

Consider the CAT-5 Hurricane Netting components as building blocks. Using sound engineering principles, the use of the product is limited only to the imagination*.

Use the CAT-5 Hurricane Netting System to cover, hold down, and secure:

- Shingled and tiled roofs, soffits, added tie down for truss systems, over existing 'blue tarps' protecting previous damage
- Signs—ground and elevated
- Manufactured homes, sheds, warehouses
- General use around houses and similar structures
- Cars
- Boats
- Construction materials
- Landscaping
- Lawn furniture and related exterior items

Use in conjunction with structures that are already fitted with impact protection systems over openings to provide enhanced protection for your entire outdoor possessions.

* This product version is not impact resistant. Other versions of this product may be available as a large missile impact protection system subsequent to the approval of this version. Check the Florida Building Code website at www.floridabuilding.org for availability of additional versions of this product.

Visit www.hurricane-net.com for more information.



Technical Specifications

Ultimate pull strength per clamp/fabric = 384LB (ref. CTC test 06-006)
Allowable pull strength per clamp on fabric (1.5FS)=256LB

%Open of fabric =47%, %Solid = 53% (ref. Twitchill, fabric T30S10470)

Total equivalent force per clamp (considering openness) = 483LB

FABRIC & CLAMP CAPACITY CALCULATION EXAMPLE

Using single row of clamps over roof or similar structure:

Span: 24ft (between clamps, or on uplift portion of net, usually 1/2 the roof or leeward side of installation)

Calculated ASCE 7 uplift or wind resistance pressure =20PSF

(MWFRS or C&C as applicable, to be performed by registered professional engineer, based on design velocity and exposure and portion of the building pressure is acting on)

On center spacing of clamps = $483\text{LB}/(24\text{ft}/2*20\text{psf}) = 24\text{in O.C.}$

Note: alter clamp spacing or use intermediate clamps to achieve various alternate results. See installation illustration suggestions on the following pages. Actual installation may vary in accordance with proper engineering principles. Use in HVHZ design areas is subject to proper engineering principles and limitations.

Note: anchorage of clamps must resist the calculated load in the proper combination of shear and tension as designed by a registered professional engineer on a site-specific basis in accordance with anchoring geometry. Information presented herein is provided as a basic guide and starting point for installation of the product. Ground anchors and fasteners shall maintain their respective installation requirements and factors of safety which shall be designed and calculated by others.

Visit www.hurricane-net.com for more information.



FABRIC PREPARATION

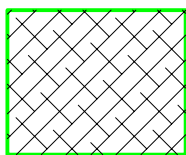
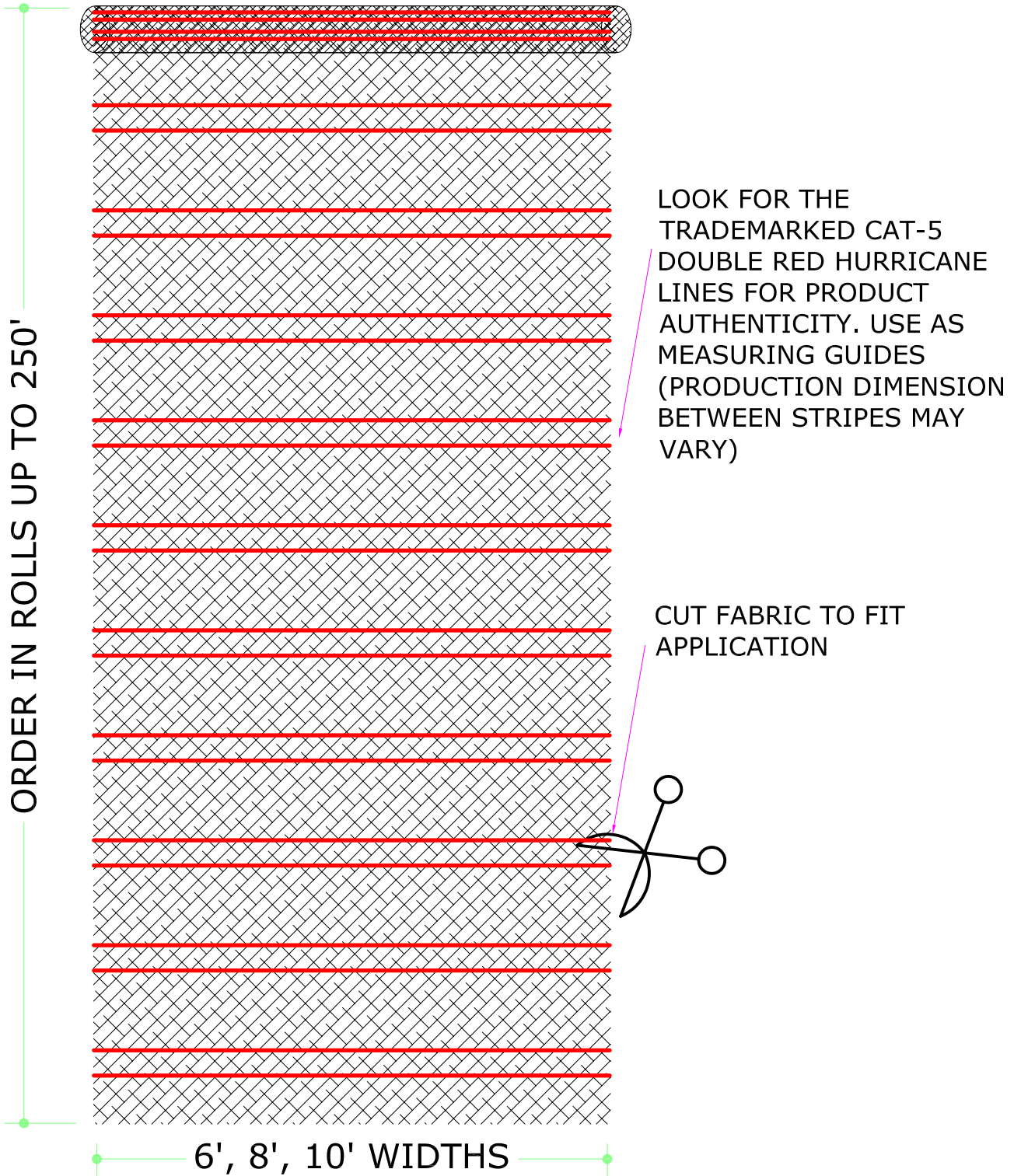

ORDER IN
PRE-PACKAGED
KITS

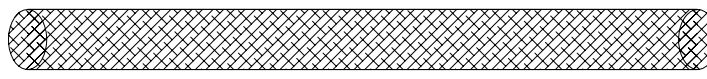

AVAILABLE IN ROLLS OR IN PRECUT KITS
WHICH INCLUDE CLAMPS

CLAMP TO FABRIC CONNECTION DETAIL

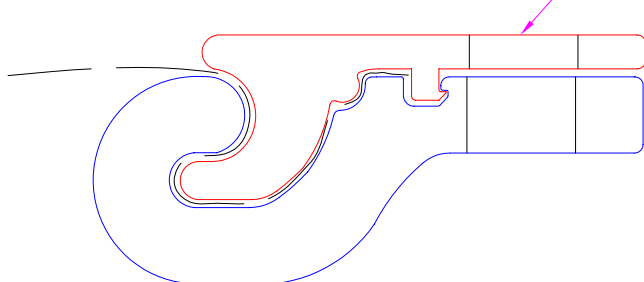
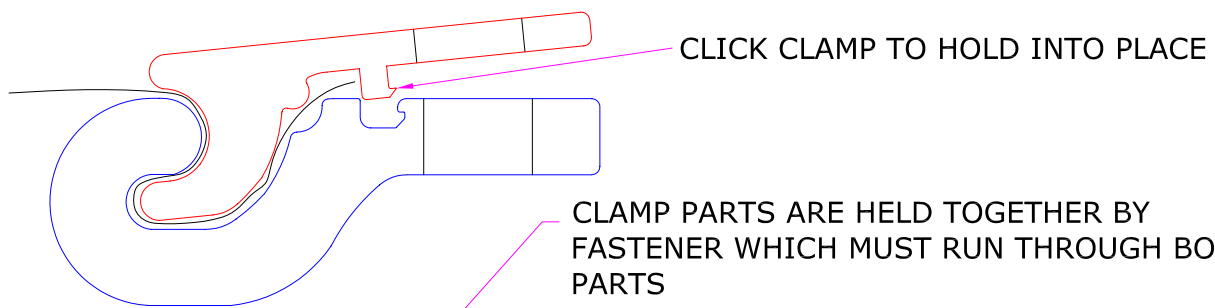
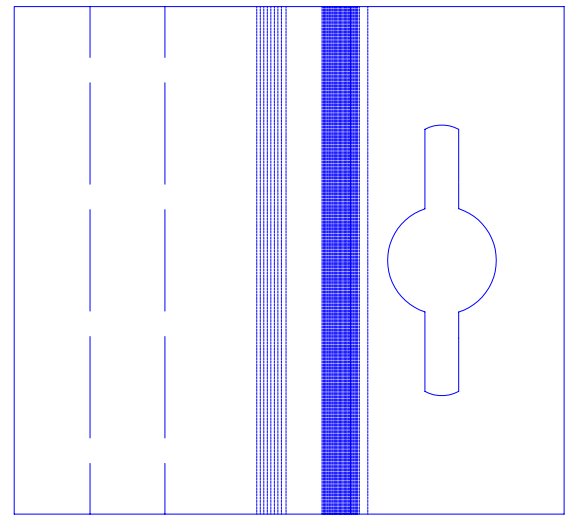
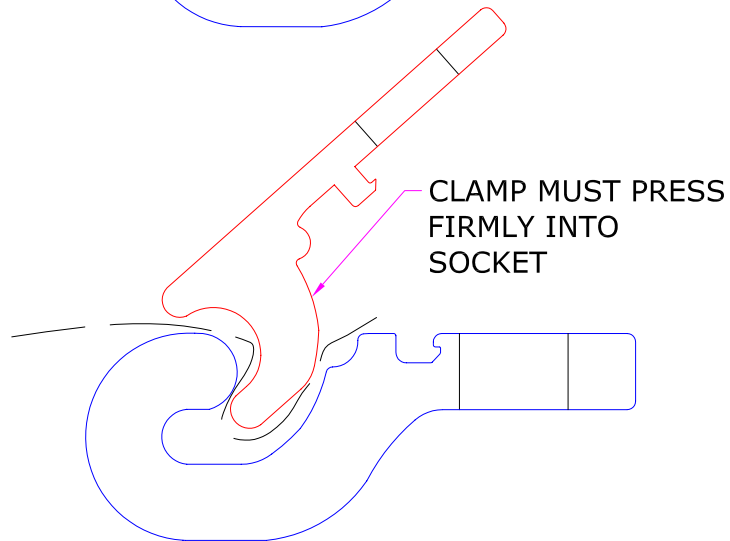
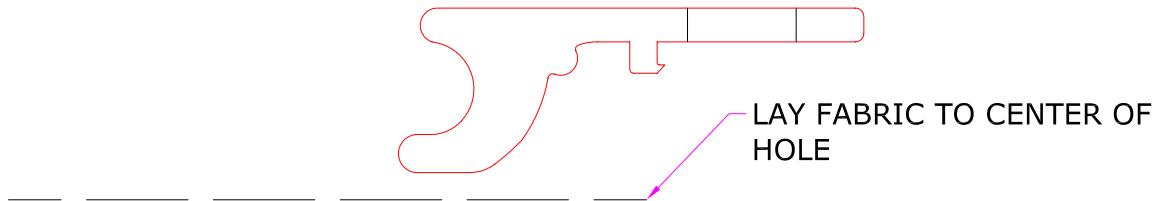

NOTE: IT IS NOT NECESSARY TO REMOVE THE CLAMPS FROM THE FABRIC AFTER USE. THEY ARE DESIGNED TO STAY IN PLACE FOR EASY FUTURE INSTALLATION. THEY MAY, HOWEVER, BE REMOVED AND REPLACED IN THE SAME OR DIFFERENT LOCATION IF DESIRED. USE A FLAT HEAD SCREWDRIVER TO PRY THE SIDE OF THE CLAMP OPEN AND PULL.

SUGGESTED MOUNTING OPTIONS

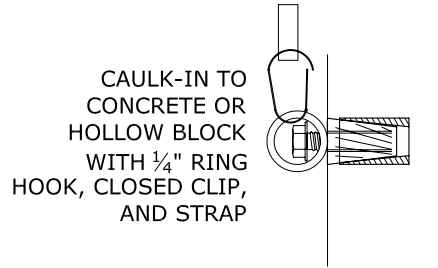
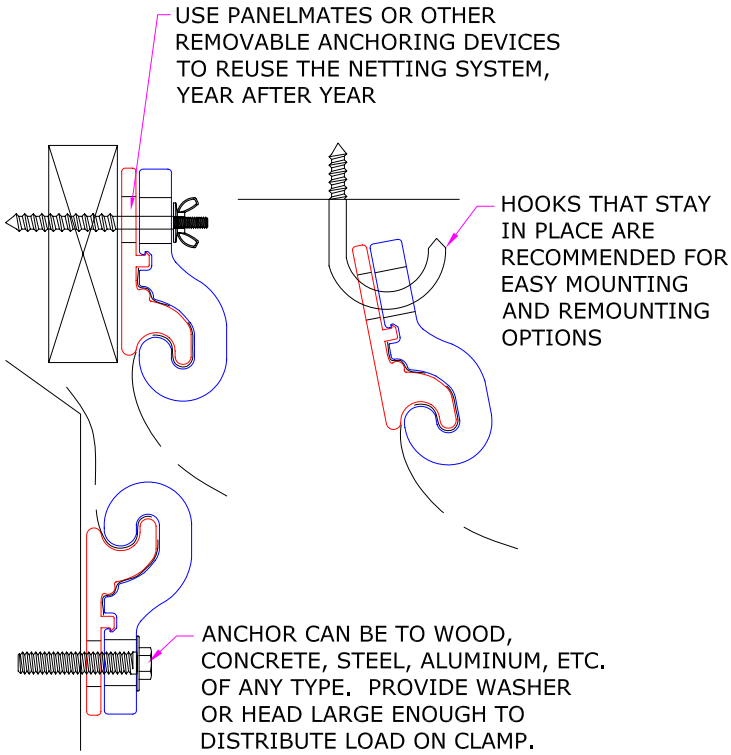

SUGGESTED GROUND ANCHORS (BY OTHERS)

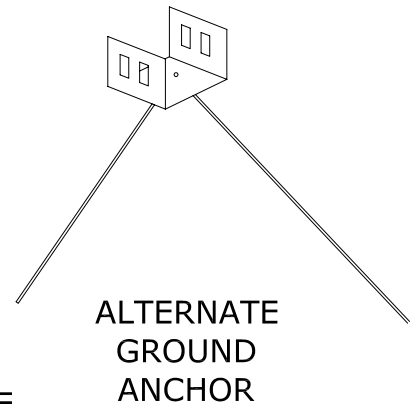
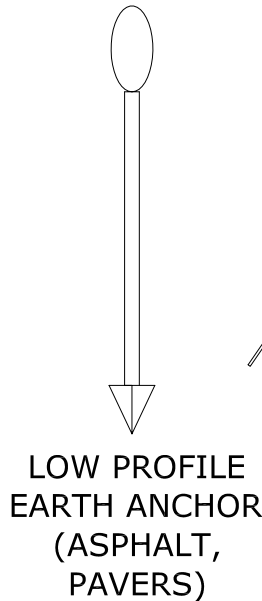
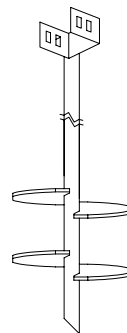
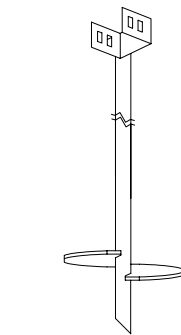

NOTE: SOIL CONDITIONS AND ANCHOR CAPACITIES MUST MATCH CALCULATED MAXIMUM PULL

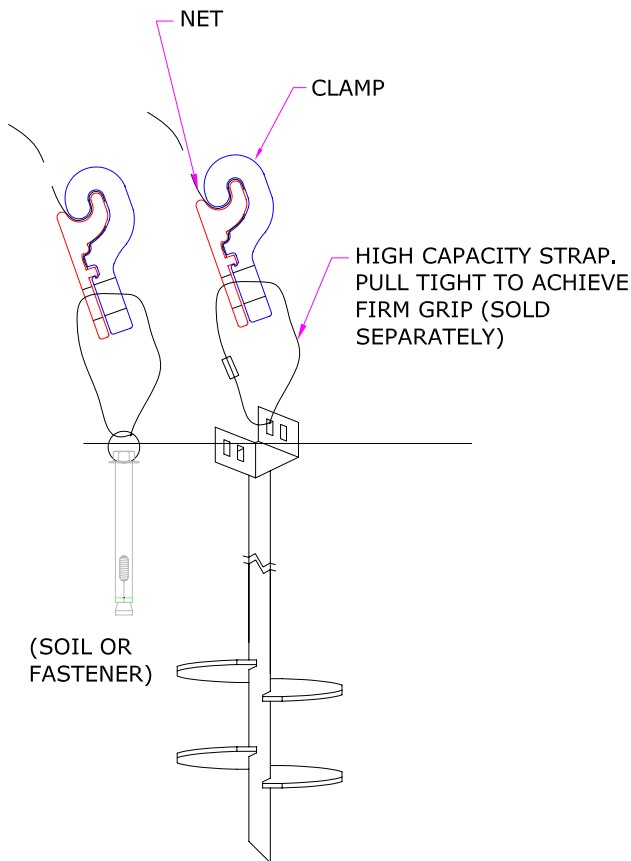

NET TO NET CONNECTION OPTIONS

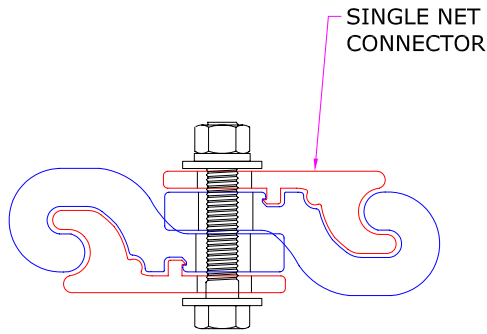

USING (2) SINGLE FABRIC CLAMPS
USEFUL FOR PROVIDING AN
ADDITIONAL MOUNTING POINT AT SEAM

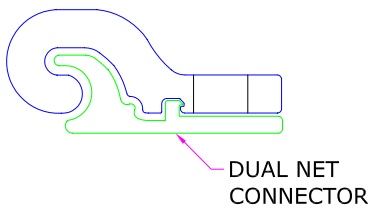
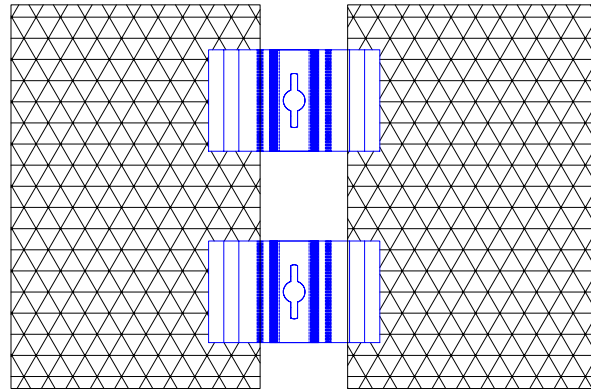

USING (1) DOUBLE FABRIC CLAMP
USEFUL FOR PROVIDING AN
INTERMEDIATE SEAM OR PROVIDE AN
ADDITIONAL TIEBACK

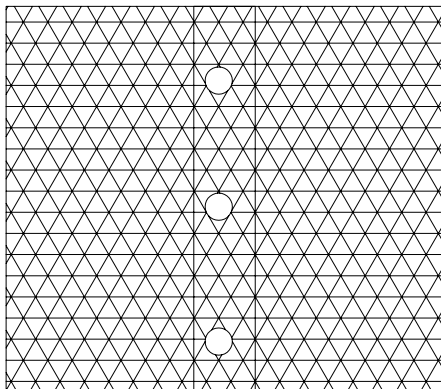
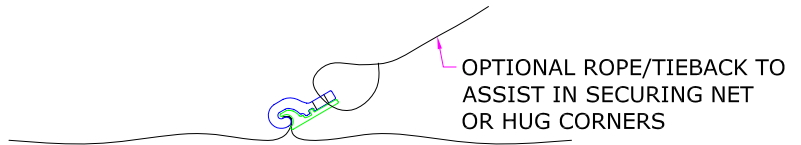

1" WASHERS & 1/4" THROUGHBOLT
STANDARD PARTS NOT SOLD WITH THE
CAT-5 NETTING SYSTEM THAT CAN
SEAM FABRIC IN A VARIETY OF
CONDITIONS

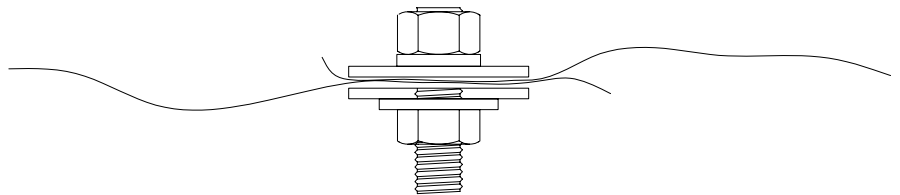

**NOTE: CLAMP SHAPE AND USE IS
PATENT PENDING**

**NOTE: THE PRIMARY LOAD PATH IS FROM
CLAMP TO CLAMP. SEAMING OF FABRIC IS
TO PROVIDE CONTINUITY ONLY.**

CREATIVE USES



GROUND MOUNTED SIGN COVERING OPTION- USE TO HELP ABATE DAMAGE OF FRAGILE SIGN FACES AND PREVENT SIGNS FROM OVERTURNING. THE CAT-5 NET CAN SECURE SIGNS OF ANY SIZE AND HEIGHT.

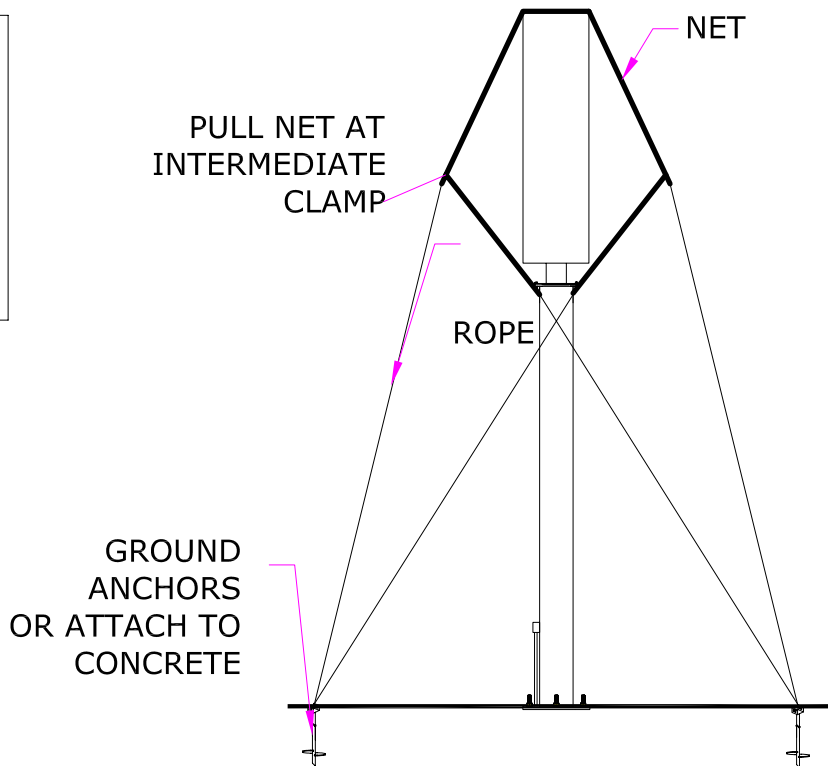
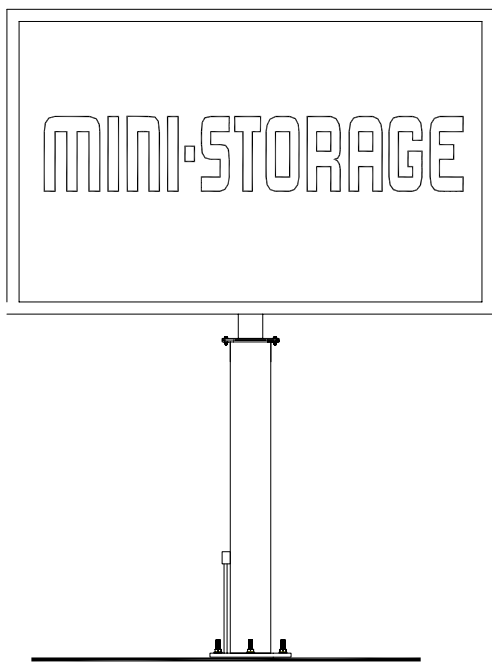
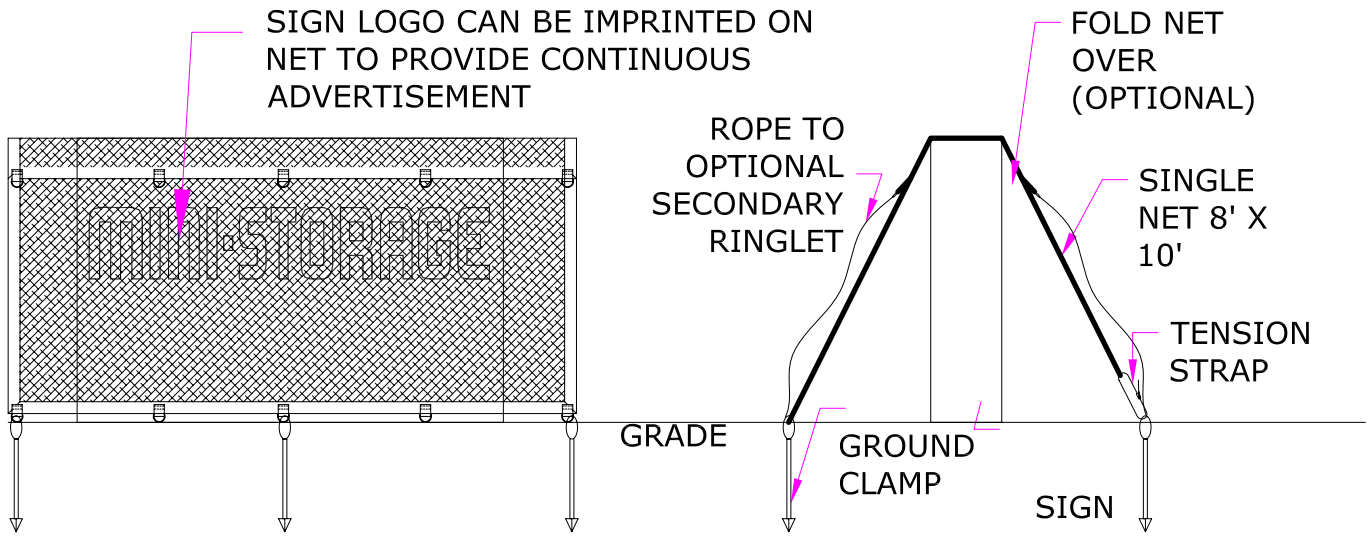

CREATIVE USES

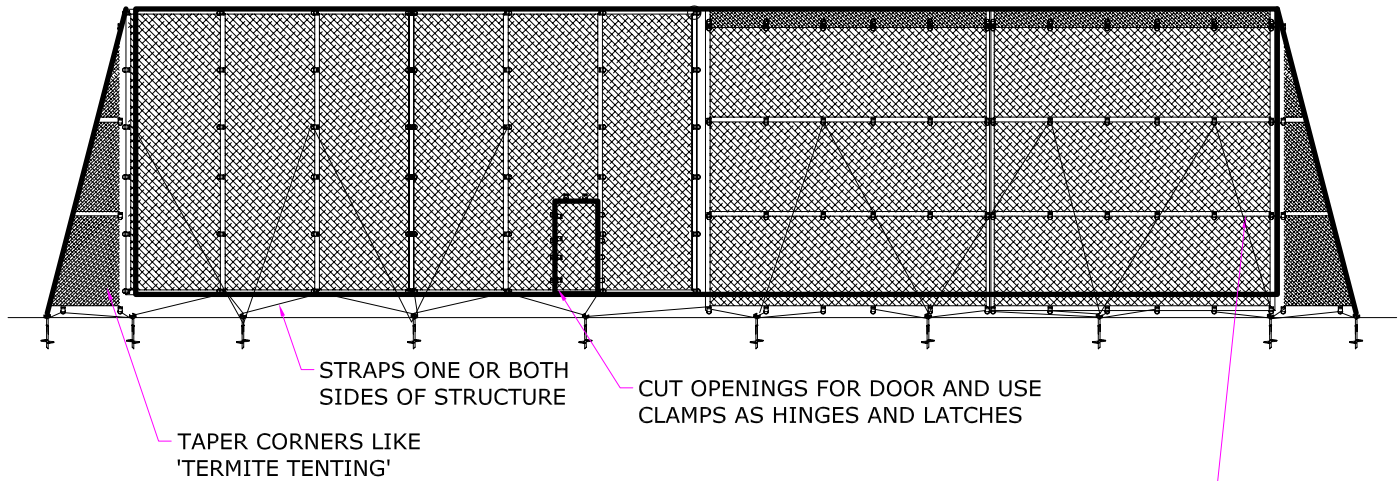

NOTE: LARGE 'WAREHOUSE LIKE' STRUCTURE SHOWN. ILLUSTRATION SHOWS VERSATILITY OF INSTALLATION AND CREATIVE SUGGESTIONS. NO ATTEMPT HAS BEEN MADE FOR ACCURATE DIMENSIONING NOR ANCHOR AND CLAMP SPACING TO PROVIDE CLARITY OF THE EXAMPLE.

MOUNT NETTING HORIZONTALLY OR VERTICALLY, TRIM AND FIT AS REQUIRED FOR TIGHT FIT WITH MINIMAL WIND RESISTANCE

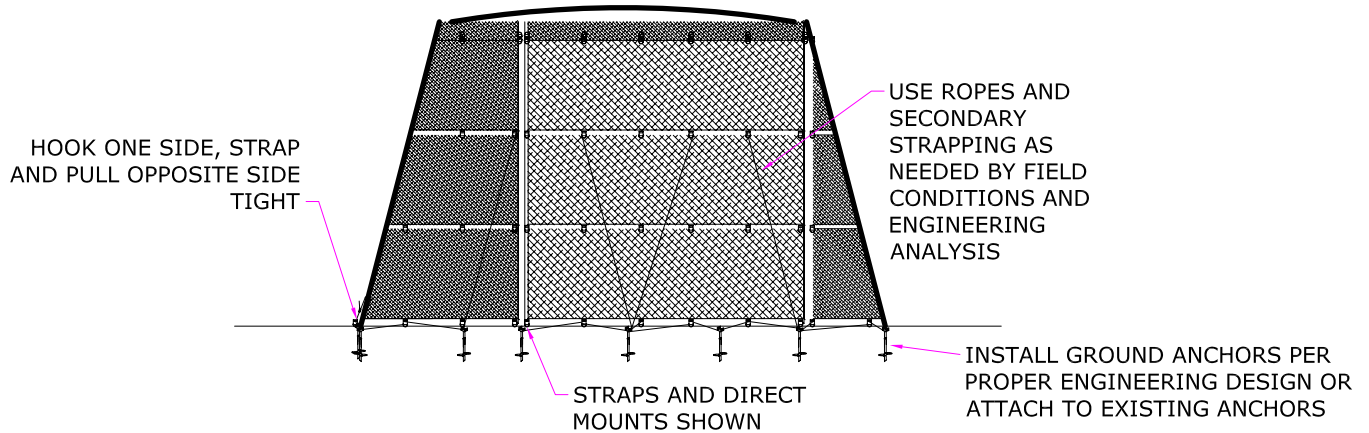

USE THE CAT-5 NETTING SYSTEM TO COVER AND PROTECT YOUR STORAGE SHED, YARD OBJECTS, MANUFACTURED HOME, OR LARGE WAREHOUSE STRUCTURE AS SHOWN HERE*

BY USING ANCHORAGE TO GROUND ANCHORS DESIGNED BY AN ENGINEER, OVERTURNING FORCES AS WELL AS UPLIFT AND DESTRUCTIVE WIND FORCES CAN EASILY BE DEFLECTED TO SAVE THE STRUCTURE AND PREVENT 'ZONE 5' CORNER ZONE VORTEXES THAT CREATE LARGE SUCTION PRESSURES AT BUILDING CORNERS.

* NOTE: FOR GLAZED OPENING COVERINGS, CONSULT THE FLORIDA PRODUCT APPROVAL SYSTEM FOR AN IMPACT VERSION OF THE CAT-5 SYSTEM NOT AVAILABLE AT THE TIME OF PRINTING OF THIS GUIDELINE, OR USE APPROVED OR EXISTING SHUTTERS OR OTHER STORM PROTECTION DEVICES. NET AND CLAMPS NOT SHOWN TO SCALE TO PROVIDE CLARITY AND INSTALLATION OPTIONS.

CREATIVE USES

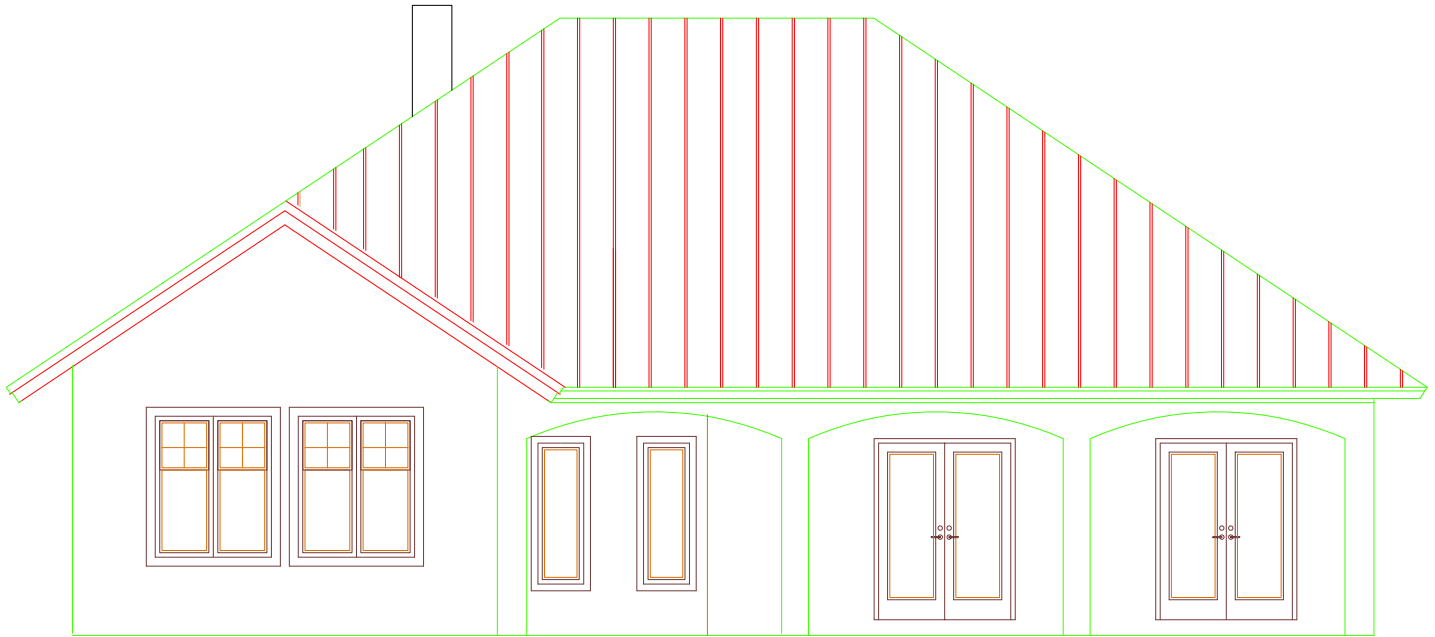

UNPROTECTED STRUCTURE

NET INSTALLED ON ROOF.
CUT AROUND ROOF
PROTRUSIONS (WILL NOT
AFFECT SURROUNDING
FIBERS)

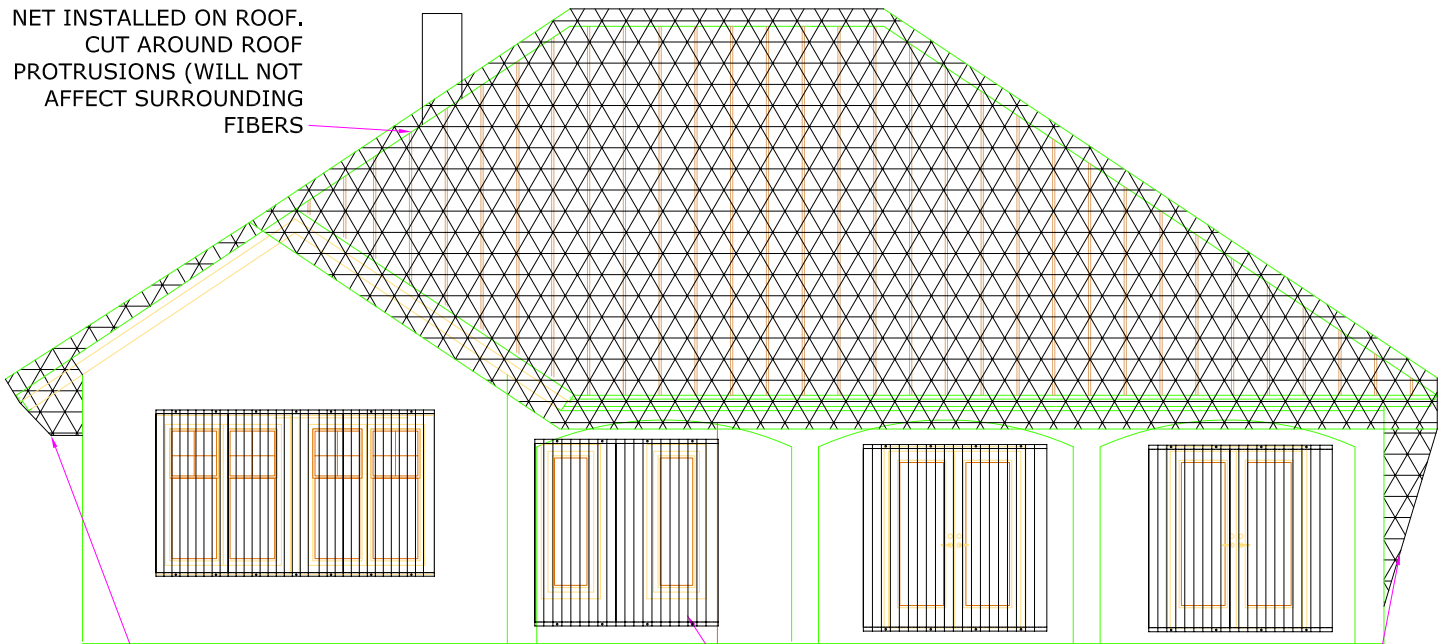

USE NET TO SECURE ROOF TO TIE BEAM FOR
ADDED UPLIFT RESISTANCE AND PROTECTION OF
SOFFITS FROM BLOWOUT FROM EXCESSIVE WINDS

NET CAN PROTECT SIDING OR GLAZING WITH
APPROVED USE PER SEPARATE APPROVAL

FULLY PROTECTED STRUCTURE

USE APPROVED STORM PROTECTION
SYSTEMS OVER GLAZED OPENINGS WHERE
THE NETTING SYSTEM CANNOT MEET
REQUIRED STANDARDS FOR INSTALLATION
OF GLAZED PROTECTION

IMPORTANT

The CAT-5 Hurricane Netting System is intended to be a wind abatement system offering varying degrees of protection to residences and other structures. With proper inspection of the product and installation by a qualified person and in accordance with these guidelines, the CAT-5 system enhances the ability of to residences and other structures to reduce the effect of high winds. However, no man-made system can totally protect any structure against the forces of nature and, in particular, the force of hurricane winds.

Upon receipt of the product, the customer should examine the contents to make certain that (1) all parts are included; (2) no part is broken, cracked, bent or not as represented in the enclosed drawings/sketches. It is highly recommended that a qualified individual inspect the system such as an engineer and or licensed general contractor. If the delivery of the system is incomplete or defective in any manner, it should not be used. Care should be taken in removing, inspecting and otherwise handling all parts.

No part should be substituted nor modified in any way. No part(s) should be added or omitted. Installation should be performed by a qualified individual such as a licensed general contractor. It is recommended that installation be reviewed by a licensed and qualified engineer. Installation should be made prior to the onset of winds or inclement weather.

Installation should not be attempted by any person not able and qualified. Installation should not be performed by children, the disabled, the elderly or any person who has an infirmity which will affect his ability to do so.

Prolonged exposure to sunlight should be avoided. Care should be taken in removal and storage of all parts. Effectiveness of reuse of the system will be determined by the care in removal of the system and integrity of components.

THERE IS NO WARRANTY WHATSOEVER, EXPRESS OR IMPLIED, AS TO MERCHANTABILITY OR FITNESS FOR A PARTICULAR USE.

THERE ARE NO ORAL WARRANTIES. THERE ARE NO WARRANTIES UNLESS SET FORTH HEREIN. NO ORAL COMMUNICATION WITH THE SELLER, BY TELEPHONE OR OTHERWISE, WILL CREATE A WARRANTY OR ANY REPRESENTATION WHATSOEVER.

Every attempt has been made to design and deliver a reasonably effective system for offering a degree of protection against damage caused by high winds. Because no system can prevent any or all damage, no warranty can be offered. The purchaser thus assumes all risk of loss if the system, however installed and used, fails to protect a structure against the effects of hurricane force winds.

