

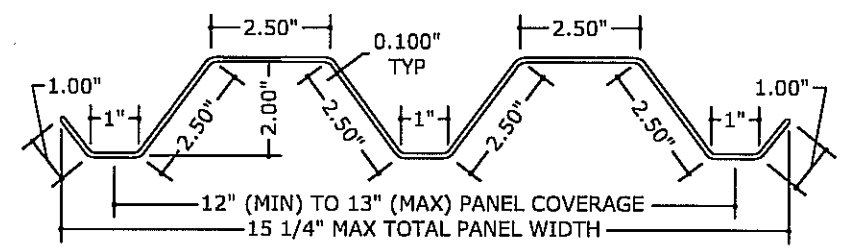

POLYCARBONATE STORM PANELS (Non-HVHZ)

FRANK L. BENNARDO, P.E.
PE0046549

09/01/2009



1 FULL PANEL PROFILE
3" = 1'-0"
(SEE GEN NOTE 7)

MOUNT WITH FASTENERS OR STUDS AT 13" O.C. MAX

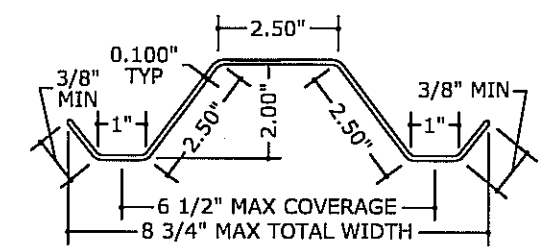

2 HALF PANEL PROFILE
3" = 1'-0"
(SEE GEN NOTE 7)

MOUNT WITH FASTENERS OR STUDS AT 6-1/2" O.C. MAX

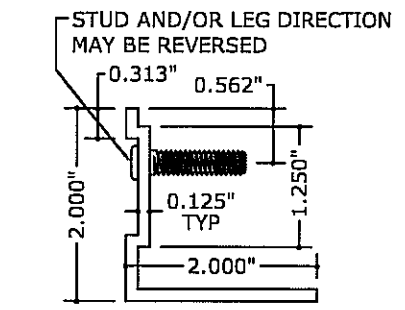

3 STUD ANGLE
6" = 1'-0"

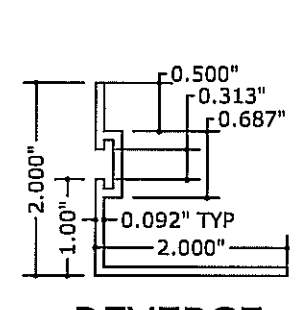

4 REVERSE 'F' ANGLE
6" = 1'-0"

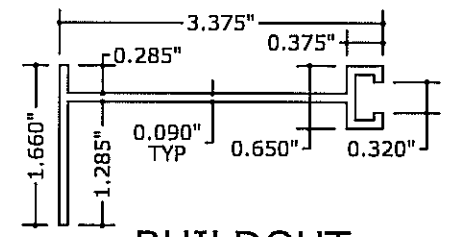

5 BUILDOUT 'F' TRACK
6" = 1'-0"

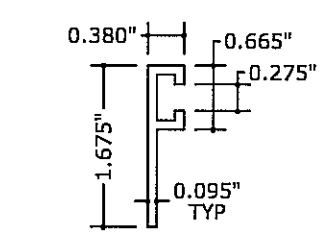

6 'F' TRACK
6" = 1'-0"

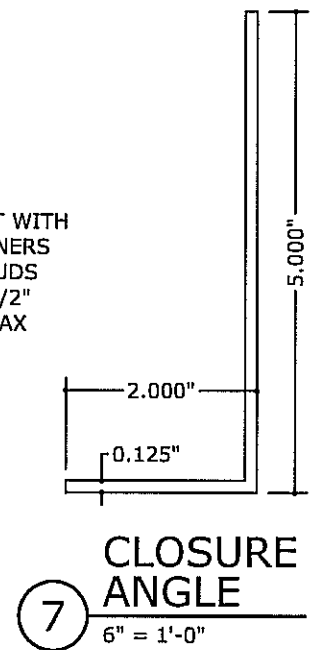

7 CLOSURE ANGLE
6" = 1'-0"

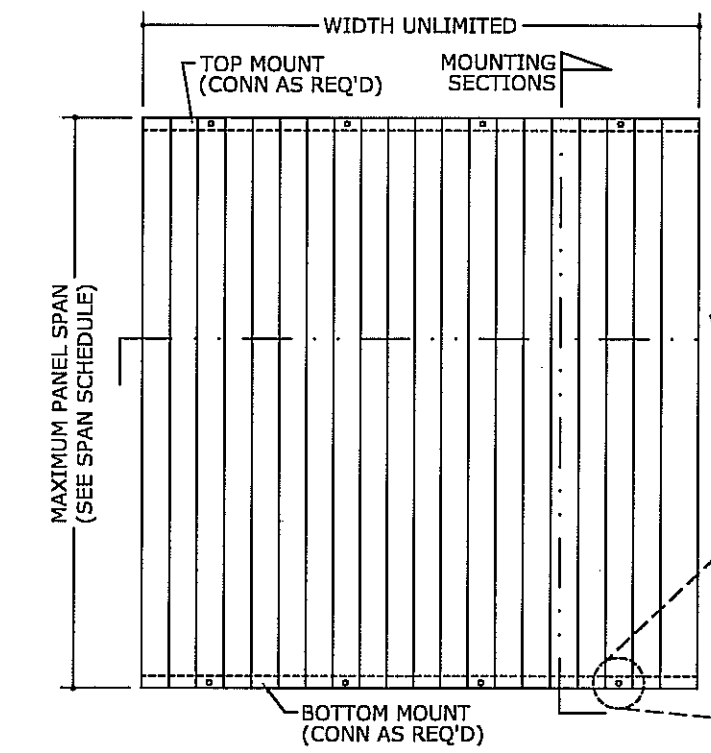

1 TYPICAL ELEVATION
1 N.T.S.

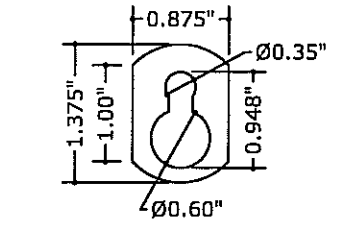

8 KEYHOLE WASHER
6" = 1'-0"

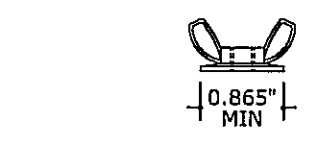

9 WASHERED WINGNUT
6" = 1'-0"

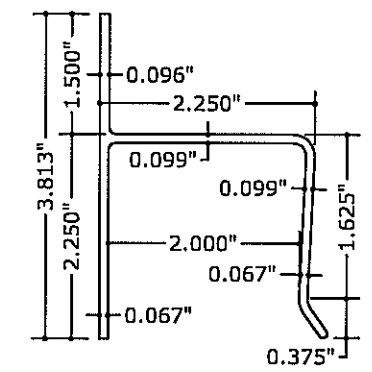

10 'H' HEADER
6" = 1'-0"

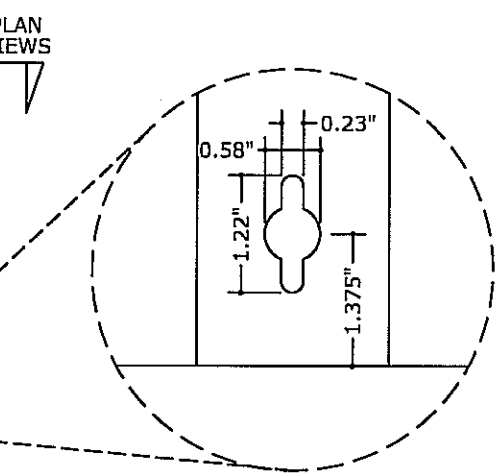

2 KEYHOLE DETAIL
1 N.T.S.
ALT: FIELD DRILL Ø3/8" HOLE (OR Ø5/8" HOLE W/ KEYHOLE WASHER)

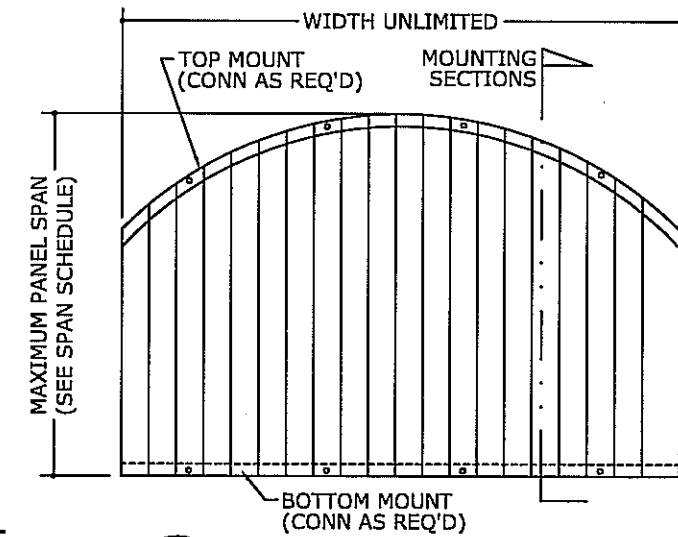

3 ALT. ARCH TOP*
1 N.T.S.

GENERAL NOTES:

- 1) THIS SYSTEM HAS BEEN TESTED AND EVALUATED AS A LARGE MISSILE IMPACT PROTECTIVE SYSTEM IN ACCORDANCE WITH THE REQUIREMENTS OF THE 2007 FLORIDA BUILDING CODE WITH 2009 SUPPLEMENTS AND THE 2006 INTERNATIONAL BUILDING/RESIDENTIAL CODE PER ASTM STANDARDS E330, E1886, & E1996. PANELS ARE APPROVED FOR USE IN FLORIDA OUTSIDE THE HIGH VELOCITY HURRICANE ZONE, OR THROUGHOUT OTHER AREAS GOVERNED BY THE 2006 IBC/IRC.
 - 2) TESTING HAS BEEN PERFORMED IN ACCORDANCE WITH THE ASTM E1996 STANDARD FOR USE IN HIGH VELOCITY WIND ZONES (WIND ZONE 4) WHERE THE BASIC WIND SPEED IS GREATER THAN 140 MPH.
 - 3) NO 33-1/3% INCREASE IN ALLOWABLE STRESS HAS BEEN USED IN THE DESIGN OF THIS PRODUCT.
 - 4) POSITIVE AND NEGATIVE DESIGN PRESSURES TO BE USED WITH THESE DRAWINGS SHALL BE DETERMINED BY OTHERS FOR SPECIFIC JOBS IN ACCORDANCE WITH THE GOVERNING CODE. WHEN CALCULATING PRESSURES PER ASCE 7-05, USE OF DIRECTIONALITY FACTOR Kd=0.85 IS ALLOWED.
 - 5) THE SYSTEM DETAILED HEREIN IS GENERIC AND DOES NOT PROVIDE INFORMATION FOR A SPECIFIC SITE. IF SITE CONDITIONS DEVIATE FROM THE CONDITIONS DETAILED HEREIN, A LICENSED ENGINEER OR REGISTERED ARCHITECT SHALL PREPARE SITE SPECIFIC DOCUMENTS TO BE USED IN CONJUNCTION WITH THIS DOCUMENT.
 - 6) CLEAR POLYCARBONATE STORM PANELS (FULL, HALF, & DOUBLE-WIDE) MAY VARY IN "COVERAGE" WIDTH UP TO THE RESPECTIVE MAXIMA SHOWN HEREIN, PROVIDED THAT THE PANEL PROFILE HEIGHT BE MAINTAINED. PANELS SHALL BE MOUNTED WITH FASTENERS OR STUDS AT MAXIMUM SPACING SHOWN FOR EACH PROFILE.
 - 7) ALL POLYCARBONATE PANELS SHALL BE MANUFACTURED BY TRANSPARENT PROTECTION SYSTEMS, Inc.
 - 8) THIS PRODUCT APPROVAL IS FOR THE USE OF CLEAR POLYCARB PANELS ONLY. ALL POLYCARB PANELS SHALL BE EXTRUDED WITH THICKNESS t=0.100" (±0.010") AND SHALL BE MANUFACTURED FROM 100% SYNTHETIC THERMOPLASTIC POLYMER RESIN (UV STABILIZED). TYPICAL SYNTHETIC THERMOPLASTIC POLYMER TENSILE STRENGTH Fy=8.908 KSI, FLEXURAL STRENGTH Fby=12.90 KSI, & FLEXURAL MODULUS IS 328.7 KSI.
 - 9) ALL EXTRUSIONS SHALL BE 6063-T6 ALUMINUM ALLOY, U.N.O.
 - 10) PANELS SHALL BE PERMANENTLY LABELED WITH A MINIMUM OF ONE LABEL PER PANEL CONTAINING THE FOLLOWING:
TRANSPARENT PROTECTION SYSTEMS, INC.
WEST PALM BEACH, FLORIDA
- NOTE: TEST STANDARDS AND PRODUCT APPROVAL NUMBERS SHALL BE INCLUDED IN PANEL LABELS.
- 11) STORM PANELS HAVE BEEN DESIGNED AND TESTED TO THE MAXIMUM SPANS AND CORRESPONDING LOADS SHOWN HEREIN. REFERENCE CONSTRUCTION TESTING CORPORATION (CTC OF MIAMI, FL) TEST REPORTS #04-009-FE-ASTM & #04-009-LE-ASTM, AS WELL AS HURRICANE TEST LAB (HTL OF RIVIERA BEACH, FL) TEST REPORTS #0239-0107-05, #0239-1013-07, #0239-0312-06, #0239-0110-07 & #0239-0813-06.
 - 12) TOP & BOTTOM MOUNTING SECTIONS MAY BE INTERCHANGED AS FIELD CONDITIONS DICTATE. PANELS MAY BE MOUNTED VERTICALLY OR HORIZONTALLY AS APPLICABLE.
 - 13) USE OF KEYHOLE WASHERS IS OPTIONAL IN CONJUNCTION WITH ANY MOUNTING CONDITION. HOLES MAY BE FIELD DRILLED AT Ø3/8" (OR Ø5/8" WITH KEYHOLE WASHER) WITH ANY FASTENER TYPE. WASHERED WINGNUTS SHALL HAVE 0.865" MINIMUM WASHER DIAMETER.
 - 14) ALL BOLTS & WASHERS SHALL BE ZINC COATED STEEL, GALVANIZED STEEL, OR STAINLESS STEEL WITH A MINIMUM TENSILE YIELD STRENGTH OF 60 KSI.
 - 15) THE HURRI-OUT EGRESS STORM PANEL DETAILS ARE INTENDED TO ALLOW THE POSSIBILITY OF REMOVING PANELS FROM INSIDE OF DWELLING. RESULTS MAY VARY ACCORDING TO INSTALLATION, END-USER, AND TRAINING, ETC. ENGINEERING EXPRESS AND TRANSPARENT PROTECTION SYSTEMS DO NOT ASSUME ANY RESPONSIBILITY OR LIABILITY ASSOCIATED WITH USE OF THIS INSTALLATION AND OR ITS APPLICATIONS.

*NOTE: FOR ALTERNATE ARCH TOP INSTALLATIONS, THE TOP TRACK OR U-HEADER SHALL BE CUT INTO 6" MINIMUM ADJACENT SEGMENTS. EACH SEGMENT SHALL HAVE ANCHORS SPACED PER THE ANCHOR SCHEDULE, WITH A MINIMUM OF (2) ANCHORS PER SEGMENT. ANCHORS SHALL BE 1-1/2" MIN FROM ENDS OF EACH SEGMENT AND SPACED 3" MINIMUM FROM ADJACENT ANCHORS. FOR STUDDED TRACKS ONLY, THERE SHALL BE A MINIMUM OF (1) STUD PER SEGMENT FASTENED TO THE STORM PANEL. STUDS SHALL BE LOCATED 2" MINIMUM FROM ENDS OF EACH SEGMENT.

ENGINEERING EXPRESS
160 SW 12th AVENUE, #106
DEERFIELD BEACH, FL 33442
PH: (954) 354-0660 FAX: (954) 354-0443
WWW.ENGEXP.COM

TPS Transparent Protection Systems, Inc.
6643 42nd Terrace North
West Palm Beach, FL 33407
CLEARGUARD POLYCARBONATE STORM PANELS
FOR USE OUTSIDE THE HVHZ
FLORIDA STATEWIDE APPROVAL

REMARKS	DRWN	CHKD	DATE
ADD'L DETAILS & SPANS	FLB	FLB	08/20/09
2ND ISSUE	CL	FLB	9/15/05
ClearMAX PROFILE ADDED	CL	FLB	8/5/05
2007 FCC REVISION	KL	CL	2/6/06
2007 FCC REVISION	KL	CL	12/29/08

THIS DOCUMENT IS THE PROPERTY OF FRANK L. BENNARDO, P.E. AND SHALL NOT BE REPRODUCED IN WHOLE OR PART WITHOUT WRITTEN CONSENT OF FRANK L. BENNARDO, P.E. TO THIS DOCUMENT ARE NOT PERMITTED AND SHALL BE PENALIZED.

COPYRIGHT FRANK L. BENNARDO P.E.
08-TPS-0008
SCALE: 1/2"
PAGE DESCRIPTION: 02
1

F:\01 Project Files\Transparent Protection (TPS)\2008108-TPS-0008 ClearGuard Polycarbonate Storm Panels, Non-HVHZ (FSA).dwg
09/01/2009 - 3:33pm
rbanfield

F:\01 Project Files\Transparent Protection (TPS)\2008\08-TPS-0008 ClearGuard Polycarbonate Storm Panels, Non-HVHZ (FSA).dwg
 09/01/2008 - 3:35pm
 rbarlett

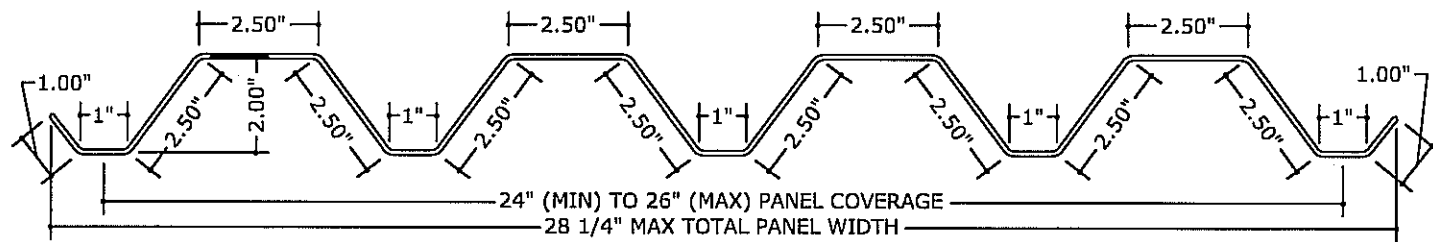

11 "CLEARMAX™" DOUBLE-WIDE PANEL PROFILE
 3" = 1'-0" (SEE GEN NOTE 6)

MOUNT WITH FASTENERS OR STUDS AT 13" O.C. MAX

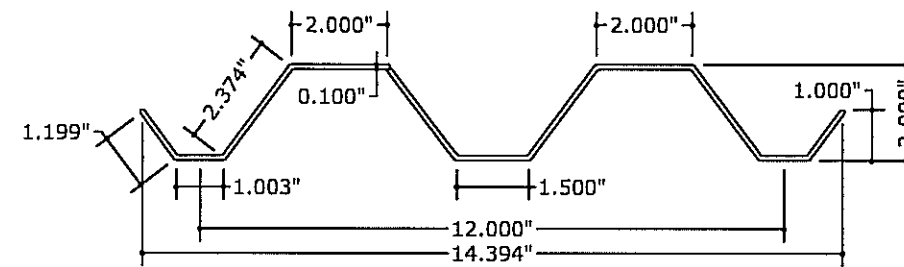

12 ALT. FULL PANEL PROFILE
 N.T.S. (SEE GEN NOTE 6)

MOUNT WITH FASTENERS OR STUDS AT 13" O.C. MAX

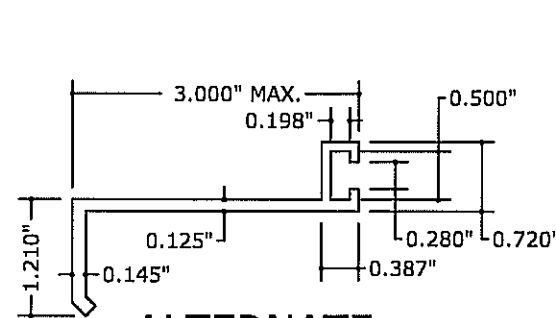

13 ALTERNATE B.O. 'F' TRACK
 6" = 1'-0"

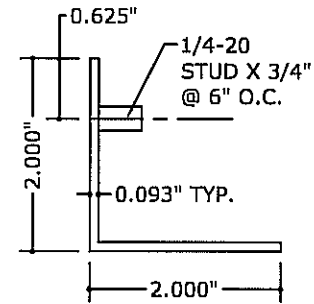

14 ALTERNATE STUD ANGLE
 6" = 1'-0"

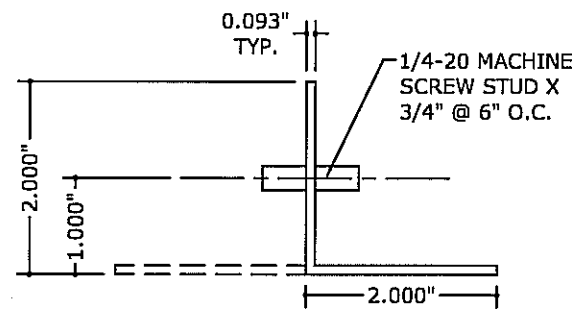

15 STUDDED ANGLE
 6" = 1'-0"

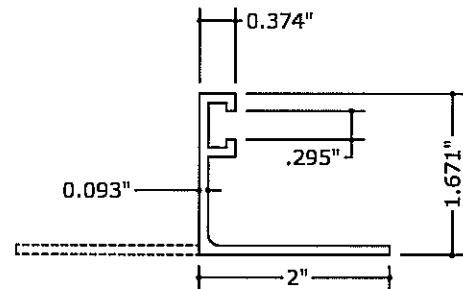

20 'F' TRACK ANGLE
 6" = 1'-0"

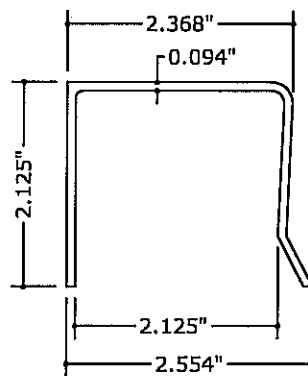

16 U-HEADER
 N.T.S. 6063-T6

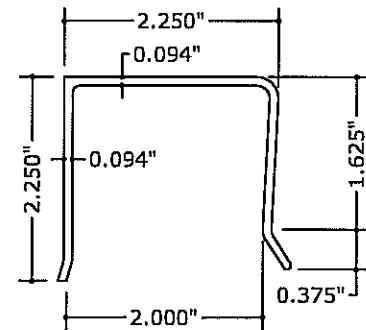

17 ALTERNATE U-HEADER
 N.T.S. 6063-T6

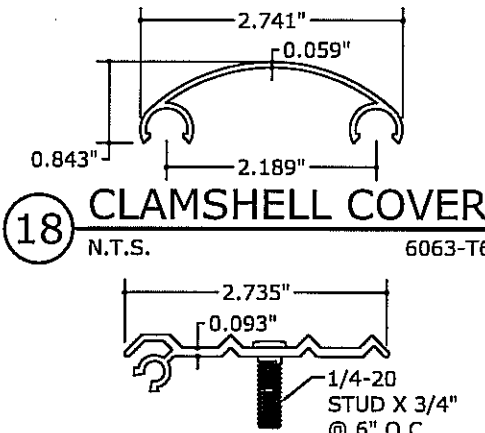

18 CLAMSHELL COVER
 N.T.S. 6063-T6

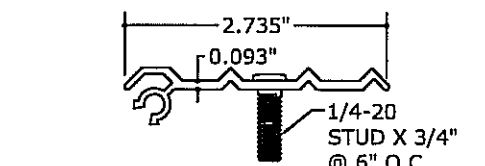

19 CLAMSHELL TRACK
 N.T.S. 6063-T6

MAXIMUM PANEL SPAN SCHEDULE (POSITIVE CONN.)

LOAD (psf)	MAX SPAN (ft)
38	12'-0"
40	11'-5"
45	10'-1"
50	9'-1"
55	8'-3"
60	7'-7"
65	7'-0"
70	6'-7"
75	6'-1"
80	5'-9"
90	5'-1"
100	4'-7"
110	4'-2"
120	3'-10"

MAXIMUM PANEL SPAN SCHEDULE (W/ "H" HEADER)

LOAD (psf)	MAX SPAN (ft)
17.3	8'-7"
24.2	7'-9"
34.6	7'-0"
41.6	6'-0"
55.4	5'-0"
104	4'-0"

MAXIMUM PANEL SPAN SCHEDULE (W/ "U" HEADER)

MAX SPAN (ft)	MAX DESIGN PRESSURES	
	POSITIVE (psf)	NEGATIVE (psf)
6'-3"	35	38
5'-3"	48	48
4'-4"	78	80

MAXIMUM SPAN SCHEDULE NOTES:

1. SPANS SHOWN IN "MAX PANEL SPAN SCHEDULES" ARE MAXIMUM ALLOWABLE SPANS AT EACH RESPECTIVE DESIGN PRESSURE.
2. THE <POSITIVE CONNECTION> SPAN SCHEDULE MAY BE USED TO DETERMINE MAXIMUM ALLOWABLE SPANS FOR PANELS INSTALLED USING ANY COMBINATION OF MOUNTING EXTRUSIONS INVOLVING A POSITIVE CONNECTION - i.e. ALL INSTALLATIONS WHICH DO NOT INCLUDE AN "H" OR "U" HEADER.
3. THE <WITH "H" HEADER> SPAN SCHEDULE SHALL BE USED FOR ALL INSTALLATIONS WHICH INCLUDE AN "H" HEADER.
4. THE <WITH "U" HEADER> SPAN SCHEDULE SHALL BE USED FOR ALL INSTALLATIONS WHICH INCLUDE A "U" HEADER.
4. TABLES ARE VALID FOR PANELS MOUNTED HORIZONTALLY OR VERTICALLY. SPAN DIRECTION IS ALWAYS PERPENDICULAR TO LINE OF ANCHORAGE.

FRANK L. BERNARDO, P.E.
PE0046549

09/01/2009

ENGINEERING EXPRESS®

160 SW 12th AVENUE, #106
DEERFIELD BEACH, FL 33442
Ph: (954) 354-0660 FAX: (954) 354-0493
WWW.ENGEXP.COM

A FRANK L. BERNARDO, P.E., INC. INNOVATION
CERT OF AUTH #8985

TPS
Transparent Protection Systems, Inc.
6643 42nd Terrace North
West Palm Beach, FL 33407

CLEARGUARD POLYCARBONATE STORM PANELS
FOR USE OUTSIDE THE HVHZ
FLORIDA STATEWIDE APPROVAL

REMARKS	DRWN	CHKD	DATE
ADD'L DETAILS & SPANS	RKB	FLB	08/20/08
2ND ISSUE	CL	FLB	07/15/05
2004 FBC	CL	FLB	05/05
CLEARMAX PROFILE ADDED	CL	FLB	2/6/05
2007 FBC REVISION	KL	CL	12/29/08

COPYRIGHT FRANK L. BERNARDO, P.E. AND SHALL NOT BE REPRODUCED IN WHOLE OR PART WITHOUT WRITTEN CONSENT OF FRANK L. BERNARDO, P.E. THIS DOCUMENT IS UNCONTROLLED AND MAY BE OUT OF DATE.

08-TPS-0008

SCALE: _____ OF 02

PAGE DESCRIPTION: _____

2

F:\01 Project Files\Transparent Protection (TPS)\2008\08-TPS-0008 ClearGuard Polycarbonate Storm Panels, Non-HVHZ (FSA).dwg
 09/01/2009 - 3:33pm
 rbartlett

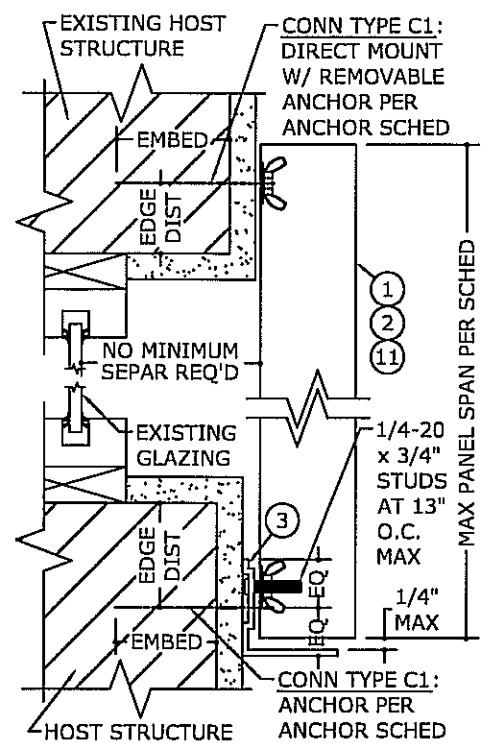

1 MOUNTING SECTION
 3" = 1'-0" VERT SECTION

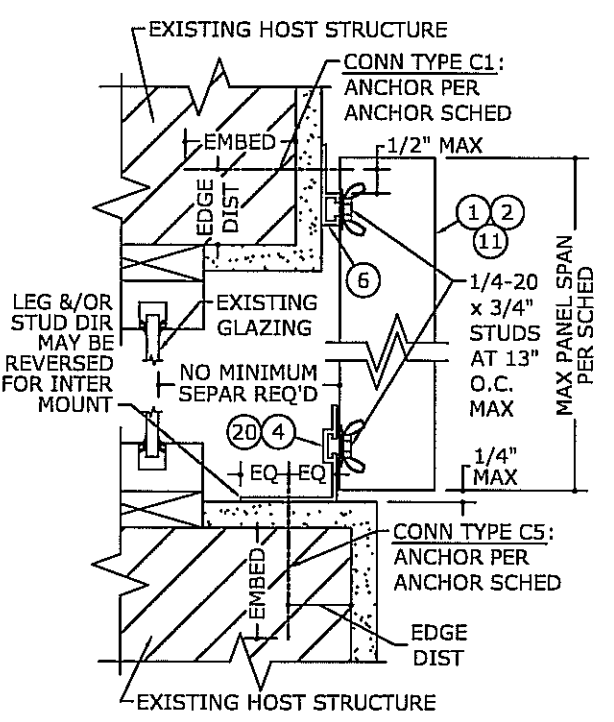

2 MOUNTING SECTION
 3" = 1'-0" VERT SECTION

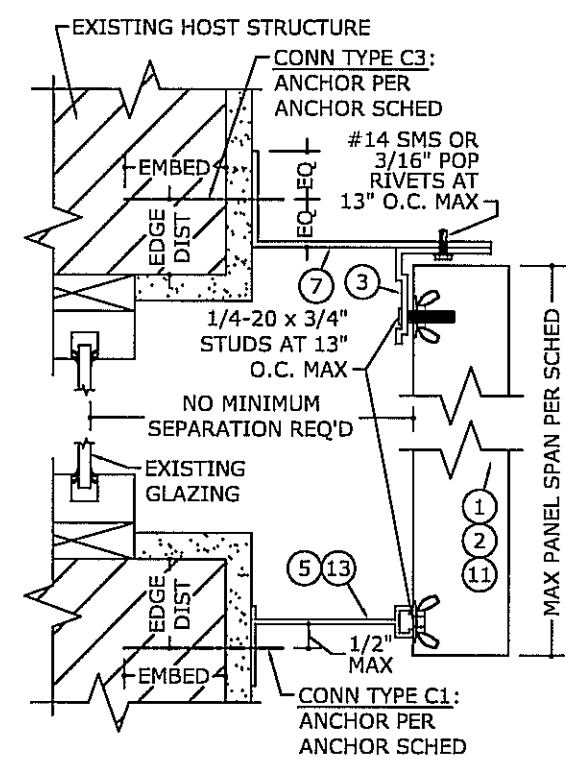

3 MOUNTING SECTION
 3" = 1'-0" VERT SECTION

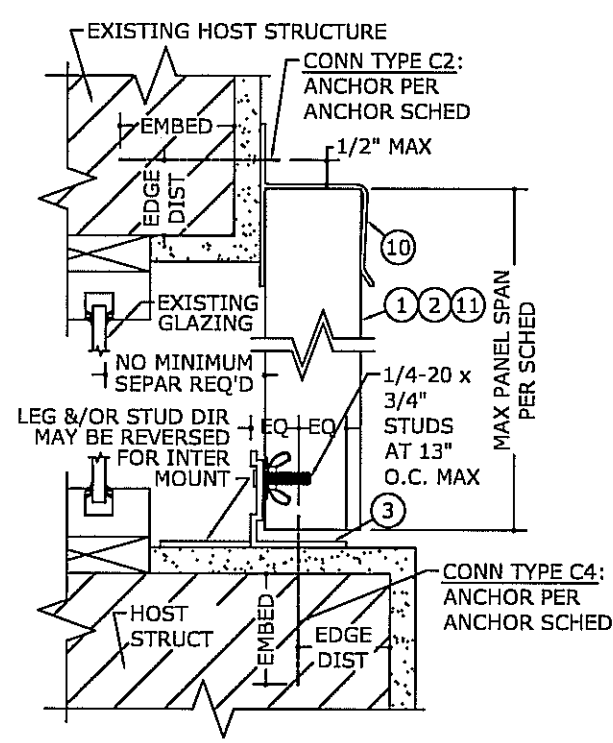

4 MOUNTING SECTION
 3" = 1'-0" VERT SECTION

HURRI-OUT™ EGRESS STORM PANEL DETAILS*

(*NOTE: SEE GENERAL NOTE #15)

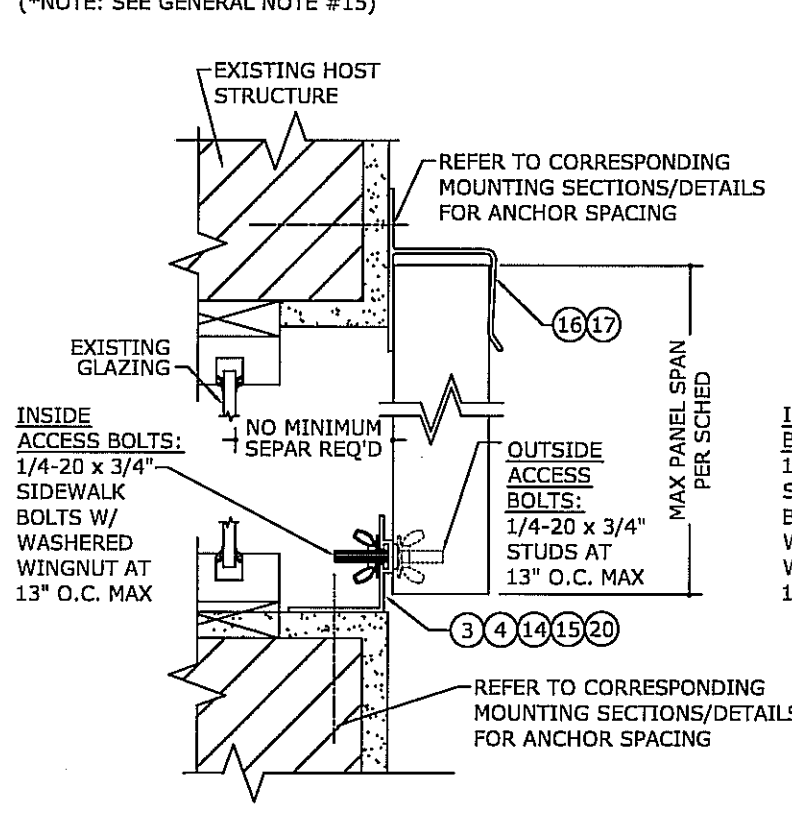

5 MOUNTING SECTION
 3" N.T.S. VERT SECTION

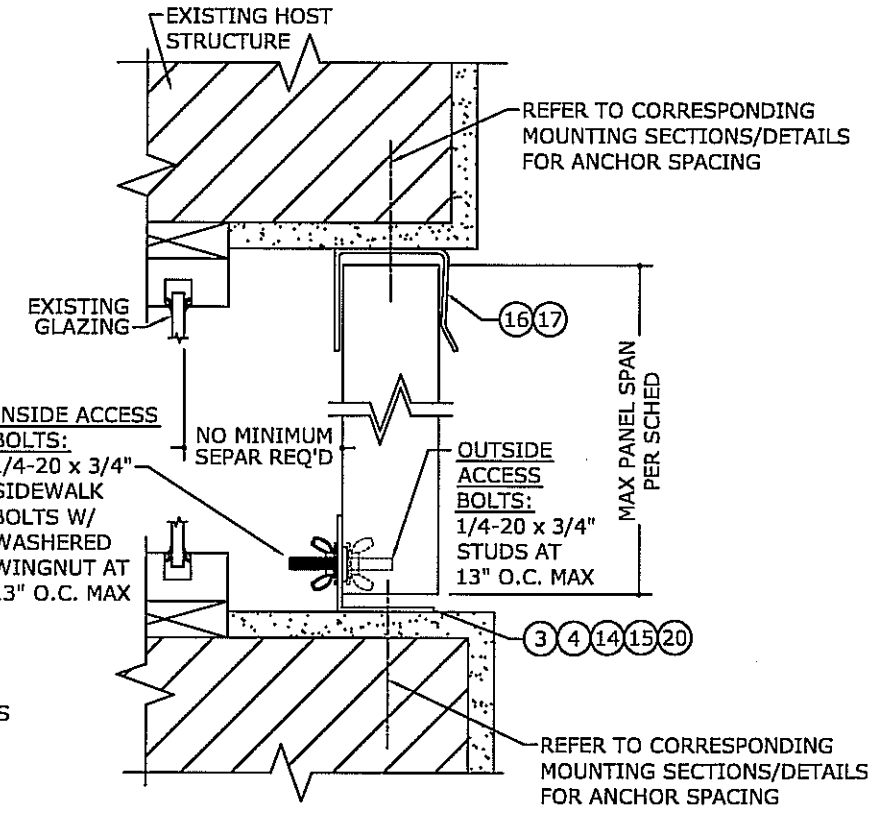

6 MOUNTING SECTION
 3" N.T.S. VERT SECTION

- ALUMINUM OR GALVANIZED STEEL SPACERS:
- REQUIRED ONLY FOR EIFS, ICF, OR OTHER MALLEABLE FINISHES.
 - OPTIONAL FOR STUCCO, BRICK, OR OTHER RIGID FINISHES.

NOTE: SHUTTER SYSTEM MAY BE ANCHORED THROUGH EXTERIOR WALL FINISH TO HOST STRUCTURE WITH ANY MOUNTING CONDITION SHOWN HEREIN.

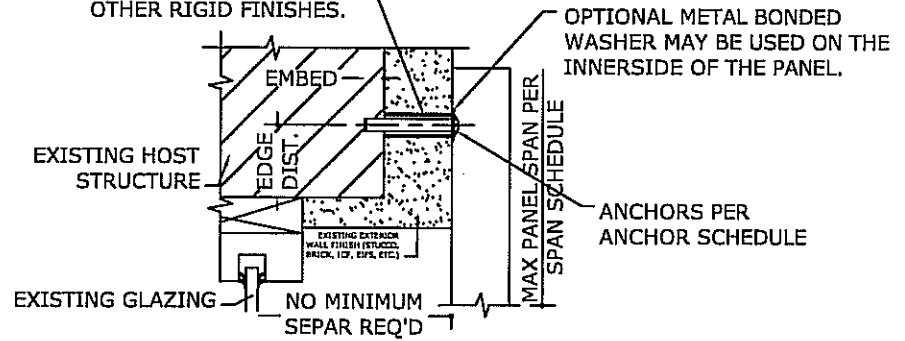

7 MOUNTING SECTION THRU EXTERIOR WALL FINISH (BRICK, ICF, EIFS, ETC.)
 3" N.T.S. VERT SECTION

FRANK L. BENNARDO, P.E.
#PE0046549

09/01/2009

ENGINEERING EXPRESS®

160 SW 12th AVENUE, #106
 DEERFIELD BEACH, FL 33442
 Ph: (954) 354-0660 Fax: (954) 354-0443
 WWW.ENGPX.COM

CERT OF AUTH #9885
 A FRANK L. BENNARDO, P.E., INC. INNOVATION

TPS

Transparent Protection Systems, Inc.
 6643 42nd Terrace North
 West Palm Beach, FL 33407

CLEARGUARD POLYCARBONATE STORM PANELS
 FOR USE OUTSIDE THE HVHZ
 FLORIDA STATEWIDE APPROVAL

REMARKS	DATE	DRWN	CHKD	DATE
ADD'L DETAILS & SPANS	08/20/09	FLB	FLB	08/20/09
2ND ISSUE		CL	FLB	07/15/05
2004 FRC		CL	FLB	06/05/05
ClearMAX PROFILE ADDED		CL	FLB	2/6/06
2007 FRC REVISION		KL	CL	12/20/08
THESE DOCUMENTS ARE THE PROPERTY OF FRANK L. BENNARDO, P.E. AND SHALL NOT BE REPRODUCED IN WHOLE OR PART WITHOUT WRITTEN CONSENT OF FRANK L. BENNARDO, P.E. ANY UNAUTHORIZED REPRODUCTION OR DISTRIBUTION OF THESE DOCUMENTS IS STRICTLY PROHIBITED AND WILL BE PROSECUTED TO THE FULL EXTENT OF THE LAW.				
COPYRIGHT FRANK L. BENNARDO P.E.				
08-TPS-0008				
SCALE: 02				
PAGE DESCRIPTION:				
3				

F:\01 Project Files\Transparent Protection (TPS)\2008\08-TPS-0008 ClearGuard Polycarbonate Storm Panels, Non-HVHZ (FSA).dwg
 09/01/2009 - 3:33pm
 rbarfield

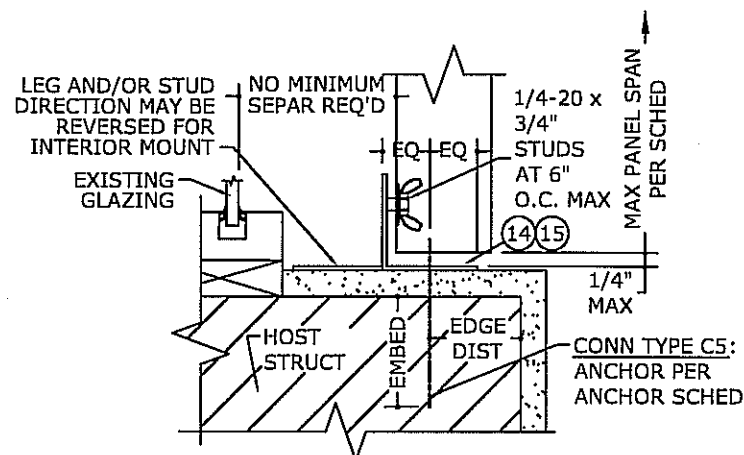

1 MOUNTING SECTION
4 3" = 1'-0" VERT SECTION

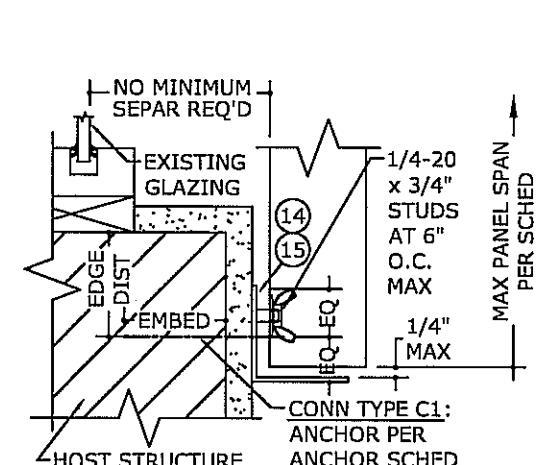

2 MOUNTING SECTION
4 3" = 1'-0" VERT SECTION

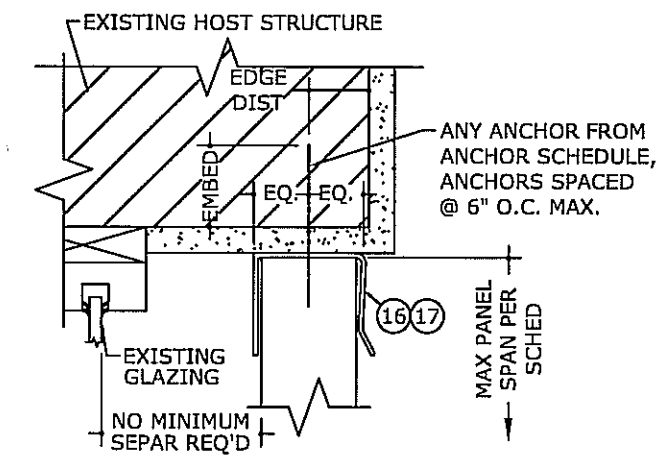

3 MOUNTING SECTION
4 N.T.S. VERT SECTION

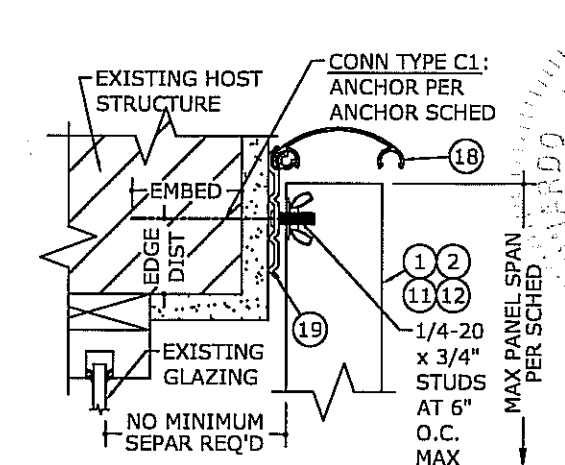

4 MOUNTING SECTION
4 N.T.S. VERT SECTION

BUILDOUT MOUNTING DETAILS

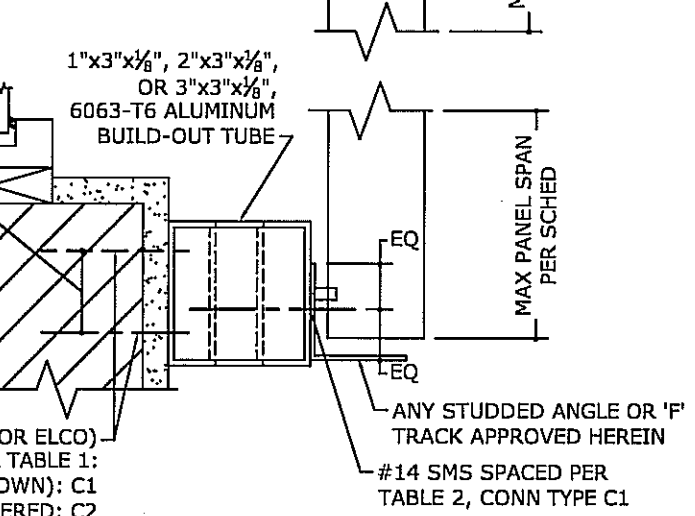
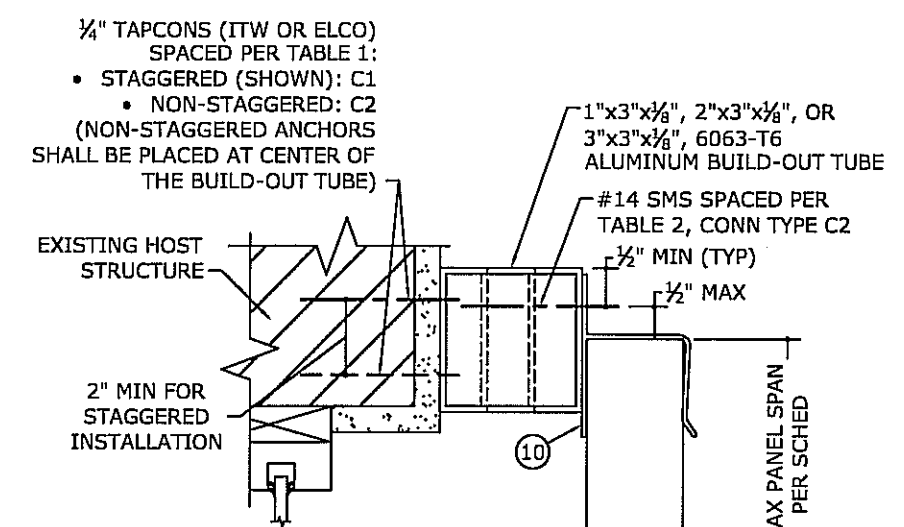

5 BUILDOUT MOUNTING DETAIL
4 N.T.S. VERT SECTION

TABLE 1*: BUILDOUT ONLY

HOST STRUCT.	LOAD (psf)	Spans Up To 6'-0"		Spans Up To 8'-6"		Spans Up To 11'-4"	
		CONN TYPE C1	CONN TYPE C2	CONN TYPE C1	CONN TYPE C2	CONN TYPE C1	CONN TYPE C2
CONCRETE	30	13.0"	13.0"	13.0"	13.0"	13.0"	11.8"
	38	13.0"	13.0"	13.0"	12.4"	13.0"	9.3"
	47	13.0"	13.0"	13.0"	10.1"	13.0"	8.5"
	54	13.0"	12.4"	13.0"	8.8"	13.0"	8.5"
HOLLOW BLOCK	120	13.0"	8.5"	13.0"	8.5"	13.0"	8.5"
	30	13.0"	8.2"	9.6"	5.8"	7.2"	4.3"
	38	10.8"	6.5"	7.6"	4.6"	5.7"	3.4"
	47	8.7"	5.2"	6.2"	3.7"	5.2"	3.1"
WOOD	54	7.6"	4.6"	5.4"	3.2"	5.2"	3.1"
	120	5.2"	3.1"	5.2"	3.1"	5.2"	3.1"
	30	13.0"	8.5"	10.0"	6.0"	7.5"	4.5"
	38	11.2"	6.7"	7.9"	4.7"	5.9"	3.6"
47	9.1"	5.4"	6.4"	3.8"	5.4"	3.3"	
54	7.9"	4.7"	5.6"	3.3"	5.4"	3.3"	
120	5.4"	3.3"	5.4"	3.3"	5.4"	3.3"	

TABLE 2*: BUILDOUT ONLY

LOAD (psf)	Spans Up To 6'-0"		Spans Up To 8'-6"		Spans Up To 11'-4"	
	CONN TYPE C1	CONN TYPE C2	CONN TYPE C1	CONN TYPE C2	CONN TYPE C1	CONN TYPE C2
30	13.0"	13.0"	13.0"	13.0"	13.0"	13.0"
38	13.0"	13.0"	13.0"	13.0"	11.3"	8.1"
47	13.0"	13.0"	12.2"	9.4"	10.3"	6.8"
54	13.0"	13.0"	10.6"	7.2"	10.3"	6.8"
120	10.3"	6.8"	10.3"	6.8"	10.3"	6.8"

NOTES:

- TABLE 1 AND 2 APPLY ONLY TO BUILDOUT MOUNTING DETAIL (7/3).
- TAPCONS SHALL BE INSTALLED WITH THE FOLLOWING MINIMUM EMBEDMENT:
 - TO CONCRETE: 1 3/4" MIN
 - TO HOLLOW BLOCK: 1 1/4" MIN
 - TO WOOD: 1 1/2" MIN
- REFER TO SHT 6 FOR ADDITIONAL ANCHOR NOTES.
- THESE MOUNTING CONDITIONS MAY BE USED INDEPENDENTLY OF ONE ANOTHER AND IN CONJUNCTION WITH OTHER MOUNTING CONDITIONS/DETAILS DEPICTED HEREIN.

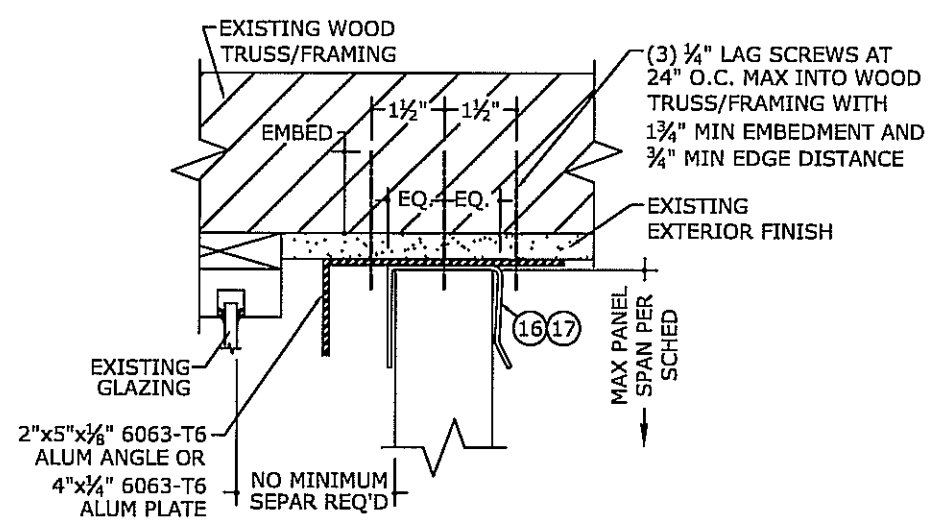

6 WOOD TRUSS MOUNT DETAIL
4 N.T.S. VERT SECTION

TABLE 3:

1/4" ITW TAPCONS WITH 1 1/4" MIN EMBED		1/4" POWERS CALK-INS WITH 7/8" MIN EMBED		#14 WOOD SCREWS WITH 1 1/2" MIN PENETRATION	
CONC	CMU	CONC	CMU	WOOD	
12" O.C.	8" O.C.	12" O.C.	11" O.C.	12" O.C.	

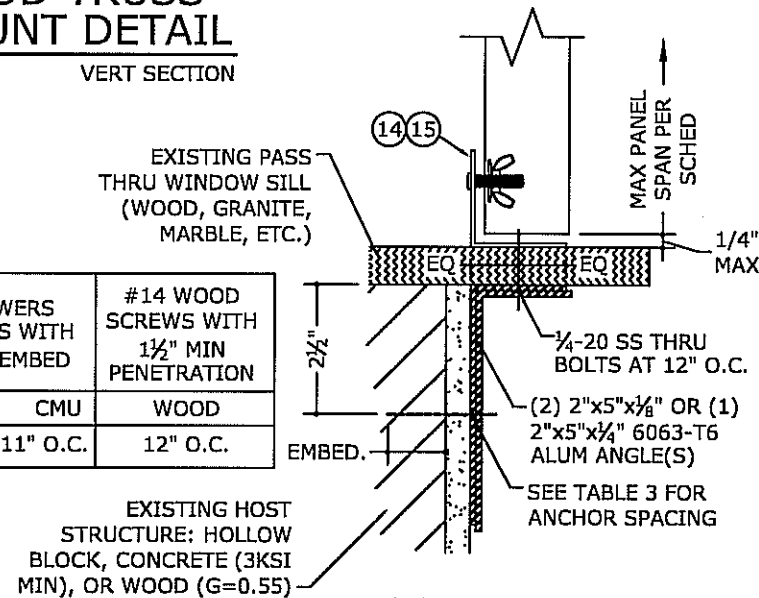

7 PASS THRU WINDOW DETAIL
4 N.T.S. VERT SECTION

FRANK L. BERNARDO, P.E.
PE0046549

09/01/2009

ENGINEERING EXPRESS

160 SW 12th AVENUE, #106
DEERFIELD BEACH, FL 33442
PH: (954) 354-0660 FAX: (954) 354-0443
WWW.ENGP.COM

CERT OF AUTH #885
A FRANK L. BERNARDO, P.E., INC. INNOVATION

Transparent Protection Systems, Inc.

TPS

6643 42nd Terrace North
West Palm Beach, FL 33407

CLEARGUARD POLYCARBONATE STORM PANELS
FOR USE OUTSIDE THE HVHZ
FLORIDA STATEWIDE APPROVAL

REVISIONS	DATE	BY	CHKD
ADD'L DETAILS & SPANS	08/20/09	RLB	FLB
2ND ISSUE	07/15/05	CL	FLB
2004 FBC	05/05	CL	FLB
ClearMAX PROFILE ADDED	2/6/05	CL	FLB
2007 FBC REVISION	12/29/08	KL	CL

THIS DOCUMENT IS THE PROPERTY OF FRANK L. BERNARDO, P.E. AND SHALL NOT BE REPRODUCED OR TRANSMITTED IN ANY FORM OR BY ANY MEANS, ELECTRONIC OR MECHANICAL, INCLUDING PHOTOCOPYING, RECORDING, OR BY ANY INFORMATION STORAGE AND RETRIEVAL SYSTEMS. THIS DOCUMENT IS NOT PERMITTED AND INVALID UNLESS OTHERWISE SPECIFIED.

COPYRIGHT FRANK L. BERNARDO P.E.

08-TPS-0008

SCALE: 02

PAGE DESCRIPTION:

4

CLOSURE DETAILS

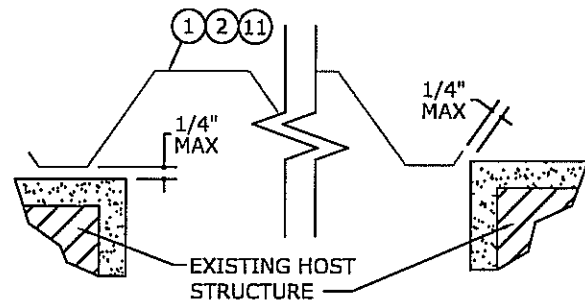

1 WALL MOUNT CLOSURE
 5 3" = 1'-0" PLAN VIEW

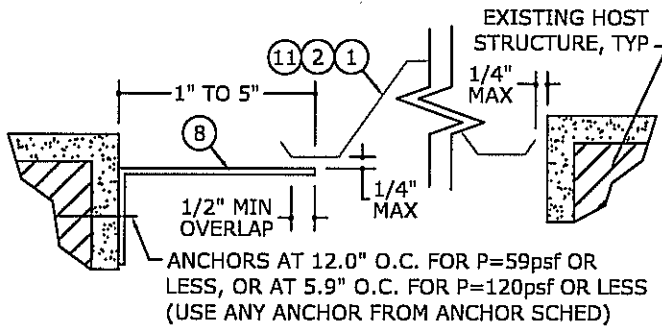

2 TRAP MOUNT CLOSURE
 5 3" = 1'-0" PLAN VIEW

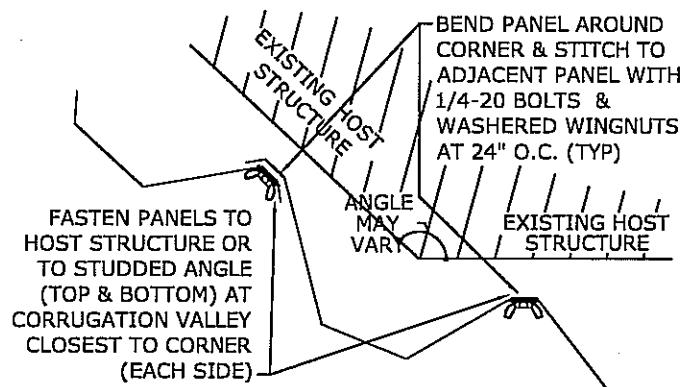

3 CORNER CLOSURE
 5 N.T.S. PLAN VIEW

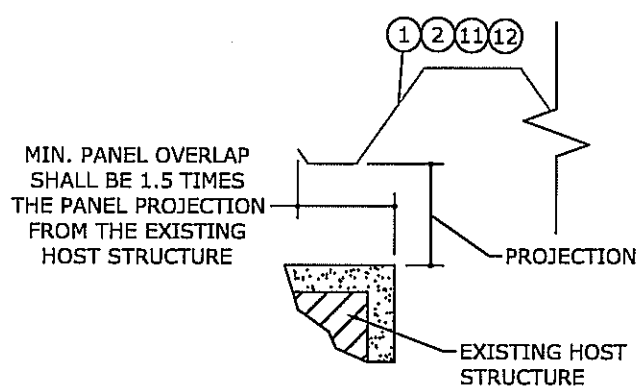

4 PANEL OVERLAP
 5 N.T.S. PLAN VIEW

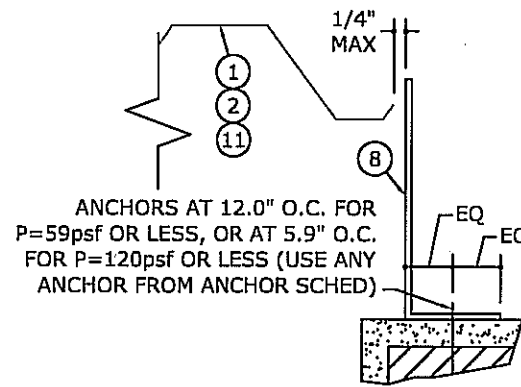

5 BUILD-OUT CLOSURE
 5 3" = 1'-0" PLAN VIEW

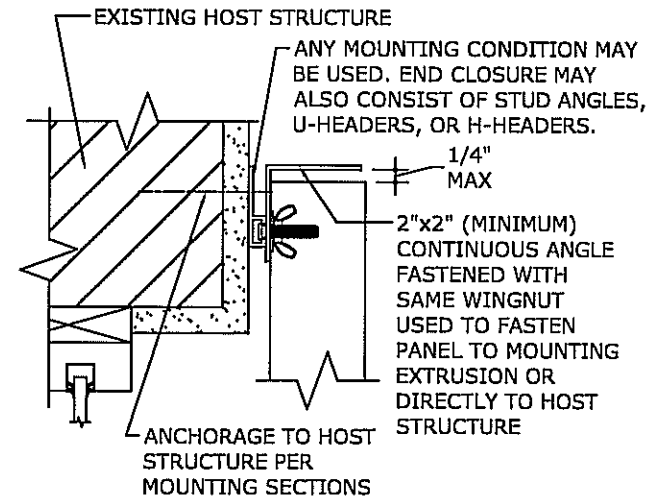

6 TOP/BOTTOM CLOSURE
 5 N.T.S. VERT SECTION

MINIMUM SPAN SCHEDULE

ONE (1) CLOSURE AT TOP OR BOTTOM

TOP OR BOTTOM WITH CLOSURE	TOP OR BOTTOM MOUNT WITHOUT CLOSURE							
	DIRECT MOUNT	STUD ANGLE (WALL MOUNT)	"F" TRACK	REVERSE "F" ANGLE	B.O. 2x5 + STUD ANGLE	B.O. "F" TRACK	"H" HEADER	STUD ANGLE (TRAP MOUNT)
DIRECT MOUNT	32"	30"	33"	30"	30"	32"	30"	30"
STUD ANGLE (WALL MOUNT)	32"	30"	33"	30"	30"	32"	30"	30"
"F" TRACK	33"	30"	35"	30"	30"	33"	30"	30"
REVERSE "F" ANGLE	32"	30"	33"	30"	30"	32"	30"	30"
B.O. 2x5 + STUD ANGLE	32"	30"	33"	30"	30"	32"	30"	30"
B.O. "F" TRACK	32"	30"	33"	30"	30"	32"	30"	30"
"H" HEADER	30"	30"	30"	30"	30"	30"	30"	30"
STUD ANGLE (TRAP MOUNT)	32"	30"	33"	30"	30"	32"	30"	30"

MINIMUM SPAN SCHEDULE

NO TOP/BOTTOM CLOSURES

TOP MOUNT	BOTTOM MOUNT							
	DIRECT MOUNT	STUD ANGLE (WALL MOUNT)	"F" TRACK	REVERSE "F" ANGLE	B.O. 2x5 + STUD ANGLE	B.O. "F" TRACK	"H" HEADER	STUD ANGLE (TRAP MOUNT)
DIRECT MOUNT	53"	32"	55"	32"	32"	53"	30"	32"
STUD ANGLE (WALL MOUNT)	32"	30"	33"	30"	30"	32"	30"	30"
"F" TRACK	55"	33"	57"	33"	33"	55"	30"	33"
REVERSE "F" ANGLE	32"	30"	33"	30"	30"	32"	30"	30"
B.O. 2x5 + STUD ANGLE	32"	30"	33"	30"	30"	32"	30"	30"
B.O. "F" TRACK	53"	32"	55"	32"	32"	53"	30"	32"
"H" HEADER	30"	30"	30"	30"	30"	30"	30"	30"
STUD ANGLE (TRAP MOUNT)	32"	30"	33"	30"	30"	32"	30"	30"

MINIMUM SPAN SCHEDULE NOTES:

- SPANS SHOWN ABOVE ARE MINIMUM ALLOWABLE SPANS BASED ON ANY COMBINATION OF MOUNTING CONDITIONS AT TOP OR BOTTOM. PANEL LENGTHS LESS THAN THOSE NOTED IN TABLES ABOVE ARE NOT ACCEPTABLE.
- NO SEPARATION FROM GLASS IS REQUIRED WHEN PANEL LENGTH IS GREATER THAN THAT NOTED FOR RESPECTIVE MOUNTING COMBINATIONS ABOVE.
- SIDE CLOSURES REQUIRED IF GAP BETWEEN PANEL AND STRUCTURE EXCEEDS DISTANCE SHOWN IN HORIZONTAL SECTION DETAILS (REF. DETAILS 6/3, 7/3 AND 9/3).
- TABLES ABOVE ARE VALID FOR PANELS MOUNTED HORIZONTALLY OR VERTICALLY.
- TOP/BOTTOM CLOSURES MAY CONSIST OF NON-STRUCTURAL 28ga (0.018" MIN) GALV STEEL OR 0.022" MIN SHEET ALUMINUM OF ALLOY 5052-H32 OR 3004-H34. REFERENCE DETAILS HEREIN FOR DEPICTION OF TOP/BOTTOM CLOSURE MOUNTING REQUIREMENTS.
- STORM PANELS MAY BE INSTALLED WITH A 12" MINIMUM SPAN WHEN INSTALLED WITH A CLOSURE ANGLE AT BOTH TOP AND BOTTOM.

FRANK L. BENNARDO, P.E.
 # PE0046549

09/01/2009

ENGINEERING EXPRESS
 160 SW 12th AVENUE, #106
 DEERFIELD BEACH, FL 33442
 PH: (954) 354-0660 FAX: (954) 354-0443
 WWW.ENGEXP.COM
 CERT OF AUTH #8885
 A FRANK L. BENNARDO, P.E., INC. INNOVATION

TPS Transparent Protection Systems, Inc.
 6643 42nd Terrace North
 West Palm Beach, FL 33407
 CLEARGUARD POLYCARBONATE STORM PANELS
 FOR USE OUTSIDE THE HVHZ
 FLORIDA STATEWIDE APPROVAL

REMARKS	DRWN	CHKD	DATE
ADD'L DETAILS & SPANS	FLB	FLB	08/20/09
2ND ISSUE	CL	FLB	8/15/05
CHANG MAX PROFILE ADDED	CL	FLB	8/5/05
2007 FBC REVISION	KL	CL	2/6/06
2007 FBC REVISION	KL	CL	12/29/08

THIS DOCUMENT IS THE PROPERTY OF FRANK L. BENNARDO, P.E. AND SHALL NOT BE REPRODUCED IN WHOLE OR PART WITHOUT WRITTEN CONSENT OF FRANK L. BENNARDO, P.E. TO THIS DOCUMENT ARE NOT PERMITTED AND SHALL BE PENALIZED.

COPYRIGHT FRANK L. BENNARDO P.E.
08-TPS-0008
 SCALE: 1/2" = 1'-0"
 PAGE DESCRIPTION:

5 OF 6

