

CLOPAY COACHMAN SERIES: CPnn, HPnn, CGnn, CXnn

HOLMES SETTLERS SERIES: SXnn

IDEAL AFFINITY SERIES: AGnn

NOTE: "nn" REPRESENTS THE ARRANGEMENT OF THE DECORATIVE OVERLAYS. THE FIRST DIGIT WILL HAVE A VALUE FROM 1 TO 3 AND THE SECOND DIGIT WILL HAVE A VALUE FROM 1 TO 5

REV	DATE	DESCRIPTION
1	12/2007	INITIAL RELEASE
2	08/2008	ADDED MPC
3	12/2008	MAX HT WAS 12'-0.

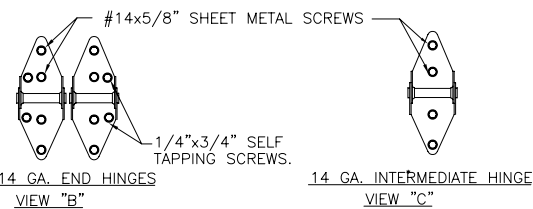
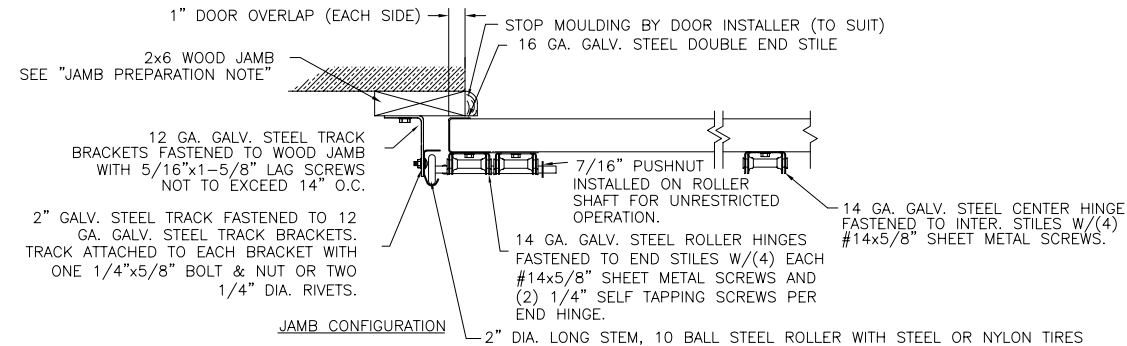
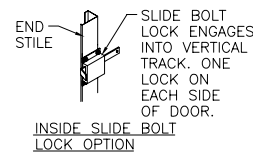
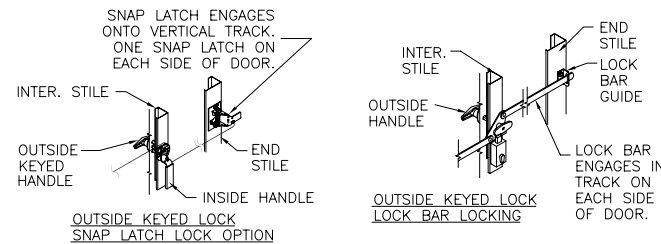
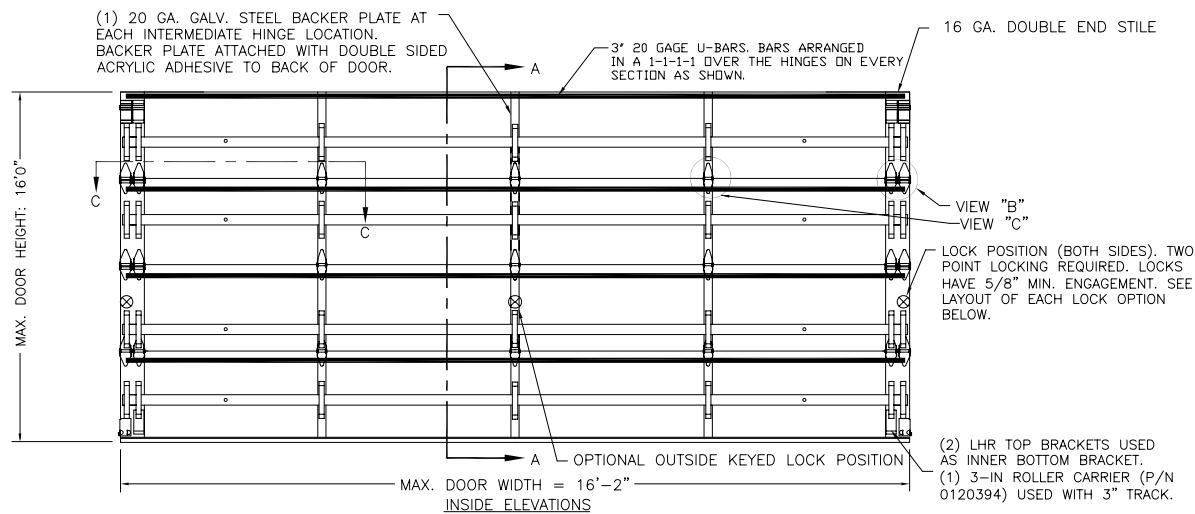

JAMB PREPARATION NOTE
THE METHOD OF ATTACHMENT TO THE SUPPORTING STRUCTURE OF THE PRESSURE TREATED 2x6 WOOD JAMBS SHALL BE APPROVED BY THE PROFESSIONAL OF RECORD FOR THE STRUCTURE AND IN ACCORDANCE WITH CURRENT BUILDING CODES FOR THE LOADS LISTED ON THIS DRAWING. PREPARATION OF JAMBS BY OTHERS.

ALL MOUNTING OF TRACK, ANGLES, HORIZONTAL TRACK SUPPORTS, AND ALL OTHER DOOR HARDWARE TO BE INSTALLED PER CLOPAY INSTALLATION INSTRUCTIONS SUPPLIED WITH DOOR SYSTEM UNLESS OTHERWISE NOTED.

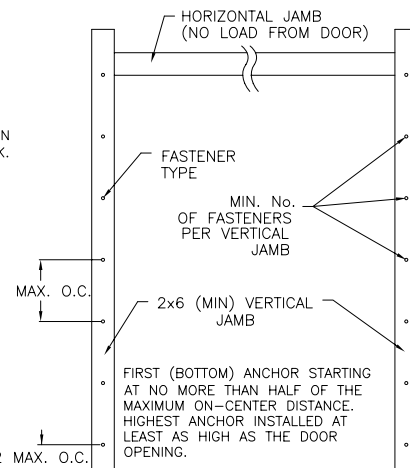

TRACK CONFIGURATION ABOVE THE DOOR OPENING DOES NOT AFFECT THE WIND LOAD RATING.

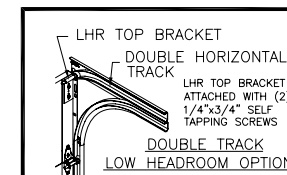

NOTE: 3" TRACK AND ROLLERS ARE REQUIRED FOR DOORS OVER 800 LBS.

SECTION A-A (SIDE VIEW)

DECORATIVE OVERLAY (PVC WITH SANVOY ASA CAPSTOCK) ATTACHED TO OUTSIDE SKIN WITH PERMANENT ADHESIVE.

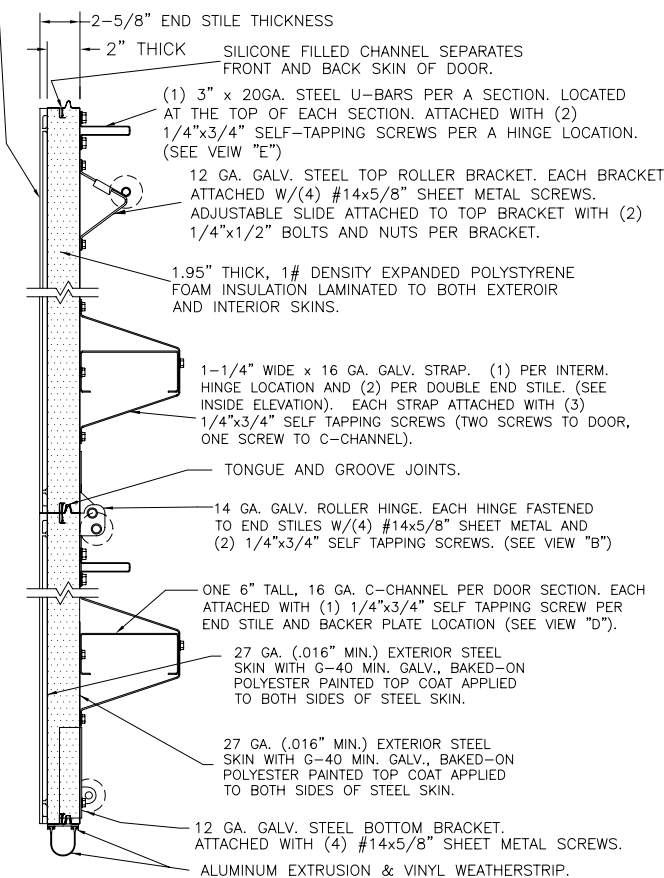

JAMB TO SUPPORTING STRUCTURE ATTACHMENT

NOTES:

1. ALL THE LOAD FROM THE DOOR IS TRANSFERRED TO THE TRACK AND THEN FROM THE TRACK TO THE 2x6 VERTICAL SYP (GRADE #2 OR BETTER) JAMBS. NO LOAD FROM THE DOOR IS TRANSFERRED TO THE HORIZONTAL (TOP) JAMB.
2. EACH VERTICAL JAMB SEES A MAXIMUM DESIGN LOAD OF +372.8 LB & -416 LB. PER LINEAR FOOT OF JAMB.
3. ALL JAMB FASTENERS MAY BE (BUT ARE NOT REQUIRED TO BE) COUNTERSUNK TO PROVIDE A FLUSH MOUNTING SURFACE.
4. A 1/3 STRESS INCREASE FOR WIND LOAD WAS NOT USED IN THE CALCULATION OF ALLOWABLE LOADS FOR ANCHORS AND FASTENERS FOR STEEL, CONCRETE AND MASONRY.
5. 2x8 JAMBS MAY BE USED WITH 3" TRACK.

WOOD FRAME BUILDINGS

STUD WALLS OF DOOR OPENING SHALL BE FRAMED SOLID BY NOT LESS THAN (3) 2x6 PRESSURE TREATED SYP (GRADE #2 OR BETTER) WOOD STUDS OF A STRESS GRADE NOT LESS THAN 1200 PSI NOMINAL EXTREME FIBER STRESS IN BENDING (F_b) FOR DOORS UP TO 8'0" HIGH OR (4) 2x6 PRESSURE TREATED SYP (GRADE #2 OR BETTER) WOOD STUDS OF A STRESS GRADE NOT LESS THAN 1200 PSI NOMINAL EXTREME FIBER STRESS IN BENDING (F_b) FOR DOORS UP TO 12'0" HIGH. STUD WALLS TO BE CONTINUOUS FROM FOOTING TO TIE BEAMS.

BLOCK WALL OR CONCRETE

2x6 SYP (GRADE #2 OR BETTER) WOOD JAMB SHALL BE ANCHORED TO GROUT REINFORCED BLOCK WALL OR CONCRETE COLUMN. BLOCK WALL CELLS SHALL BE FILLED WITH CONCRETE AND REINFORCED WITH REINFORCING BARS EXTENDING INTO THE FOOTING AND INTO TIE BEAMS. ALL BARS SHALL BE CONTINUOUS FROM THE TIE BEAMS TO FOOTING PER BLOCK WALL OR CONCRETE COLUMN. BLOCK WALLS AND CONCRETE COLUMNS TO BE DESIGNED BY THE BUILDING ENGINEER OR ARCHITECT OF RECORD AND IN ACCORDANCE WITH THE FLORIDA BUILDING CODE.

2x6 JAMB TO SUPPORTING STRUCTURE ATTACHMENT

(NOT TO BE USED FOR ATTACHMENT OF TRACK ANGLE TO 2x6 VERTICAL JAMBS OR SUPPORTING STRUCTURE)

BUILDING TYPE	FASTENER TYPE	MAXIMUM ON-CENTER DISTANCE BETWEEN FASTENERS*	STEEL WASHERS REQUIRED?
BLOCK WALL	1/4" x 1-1/4" MIN. EMBED TAPCON CONCRETE ANCHOR	6-1/4"	1" O.D.
3000 PSI MIN. CONCRETE	1/4" x 1-3/4" MIN. EMBED TAPCON CONCRETE ANCHOR	18-1/4"	1" O.D.
3000 PSI MIN. CONCRETE	1/2" x 2-1/4" MIN. EMBED SIMPSON STRONG-TIE WEDGE-ALL WEDGE ANCHOR	12"	INCLUDED
2000 PSI MIN. CONCRETE	3/8" x 1-3/4" MIN. EMBED SLEEVE ANCHOR	14"	INCLUDED
WOOD FRAME (SYP 0.55 SG)	1/2" x 3" LAG SCREW (ASTM A307, GRADE A) 1-5/8" EMBED INTO STRUCTURE	14-1/2"	1" O.D.

MINIMUM DISTANCE BETWEEN CENTER OF ANCHOR AND EDGE OF CONCRETE BLOCK: 3", EXCLUDING STUCCO THICKNESS.
* FIRST (BOTTOM) ANCHOR STARTING AT NO MORE THAN HALF OF THE MAXIMUM ON-CENTER DISTANCE. HIGHEST ANCHOR INSTALLED AT LEAST AS HIGH AS THE DOOR OPENING.
CLOPAY DOES NOT SUPPLY JAMB ATTACHMENT FASTENERS.

NOTE: SUPPORTING STRUCTURAL ELEMENTS SHALL BE DESIGNED BY A REGISTERED PROFESSIONAL ENGINEER FOR WIND LOADS SHOWN ON THIS DRAWING.

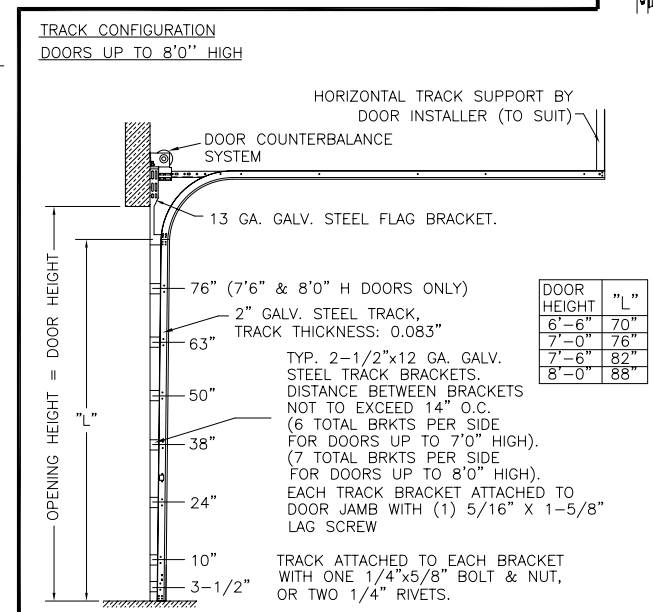

DOOR HEIGHT	"L"
6'-6"	70"
7'-0"	76"
7'-6"	82"
8'-0"	88"

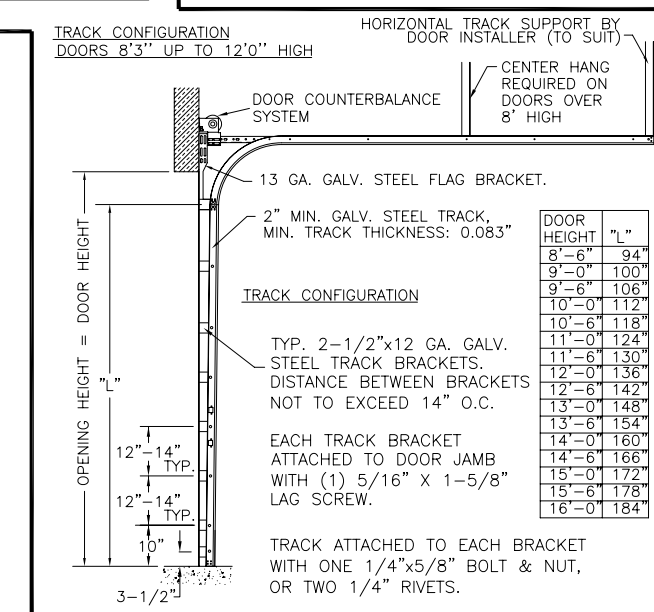

DOOR HEIGHT	"L"
8'-6"	94"
9'-0"	100"
9'-6"	106"
10'-0"	112"
10'-6"	118"
11'-0"	124"
11'-6"	130"
12'-0"	136"
12'-6"	142"
13'-0"	148"
13'-6"	154"
14'-0"	160"
14'-6"	166"
15'-0"	172"
15'-6"	178"
16'-0"	184"

THIS DOOR MEETS THE REQUIREMENTS OF THE LARGE MISSILE IMPACT AND CYCLIC TESTING.

THIS DOOR MEETS OR EXCEEDS THE DESIGN LOADS FOR THE WIND SPEEDS LISTED BELOW ACCORDING TO THE FLORIDA BLDG. CODE OR IBC (ASCE7) FOR THE FOLLOWING CONDITIONS: 1) ENCLOSED BUILDING, 2) DOOR HAS 2' OF WIDTH IN BUILDING'S END ZONE, 3) IMPORTANCE FACTOR OF 1.0, 4) ANY ROOF SLOPE, AND 5) 50% SAFETY FACTOR.

WIND SPEED (MPH)	≤ 140	150	150
EXPOSURE LEVEL	B or C	B	C
MEAN ROOF HEIGHT	30'	30'	25'

DESIGN ENGINEER: MARK WESTERFIELD, P.E.
FLORIDA P.E. #48495
NC P.E. #23832
TEXAS P.E. #91513

DESIGN LOADS: +46.6 P.S.F. & -52.0 P.S.F.
TEST LOADS: +70.0 P.S.F. & -78.0 P.S.F.

MANUFACTURING PRODUCT CODE:
MPC: DSIED-1M479



CLOPAY BUILDING PRODUCTS COMPANY
8585 DUKE BLVD.
MASON, OH 45040
(513) 770-4800

SCALE: N/A
DATE: 2/27/07
DRAWN BY: BFA
CHECKED BY:

CLOPAY WINDLOAD RATING	MAX DOOR SIZE:
W8	16'2"W x 16'0"H
DESCRIPTION: COACHMAN	
2" EPS W/OVERLAYS +46.6/-52 PSF DESIGN	
DRAWING NUMBER: B	103560
VER: IBC	