

5/8" PANEL
EXTERIOR VIEW

DESIGN PRESSURE RATING	IMPACT RATING
±60.0PSF	LARGE AND SMALL MISSILE IMPACT

REVISIONS			
REV	DESCRIPTION	DATE	APPROVED

- NOTES:
1. THE PRODUCT SHOWN HEREIN IS DESIGNED AND MANUFACTURED TO COMPLY WITH REQUIREMENTS OF THE FLORIDA BUILDING CODE.
 2. WOOD FRAMING AND MASONRY OPENING TO BE DESIGNED AND ANCHORED TO PROPERLY TRANSFER ALL LOADS TO STRUCTURE. FRAMING AND MASONRY OPENING IS THE RESPONSIBILITY OF THE ARCHITECT OR ENGINEER OF RECORD.
 3. ALLOWABLE STRESS INCREASE OF 1/3 WAS NOT USED IN THE DESIGN OF THE PRODUCT SHOWN HEREIN. WIND LOAD DURATION FACTOR Cd=1.6 WAS USED FOR WOOD ANCHOR CALCULATIONS.
 4. PANEL MATERIAL: POLYCARBONATE.
 5. APPROVED IMPACT PROTECTIVE SYSTEM IS NOT REQUIRED FOR THIS PRODUCT IN WIND BORNE DEBRIS REGIONS.
 6. FOR ANCHORING INTO WOOD FRAMING OR 2X BUCK USE 1/4" PANEL MATE OR 1/4" TAPCON SG WITH SUFFICIENT LENGTH TO ACHIEVE A 1 1/2" MINIMUM EMBEDMENT INTO SUBSTRATE. LOCATE ANCHORS AS SHOWN IN ELEVATIONS AND INSTALLATION DETAILS.
 7. FOR ANCHORING INTO MASONRY/CONCRETE USE 1/4" PANEL MATE OR 1/4" TAPCON SG WITH SUFFICIENT LENGTH TO ACHIEVE A 1 1/4" MINIMUM EMBEDMENT INTO SUBSTRATE WITH 2" MINIMUM EDGE DISTANCE. LOCATE ANCHORS AS SHOWN IN ELEVATIONS AND INSTALLATION DETAILS.
 8. ALL FASTENERS TO BE CORROSION RESISTANT.
 9. INSTALLATION ANCHORS SHALL BE INSTALLED IN ACCORDANCE WITH ANCHOR MANUFACTURER'S INSTALLATION INSTRUCTIONS AND ANCHORS SHALL NOT BE USED IN SUBSTRATES WITH STRENGTHS LESS THAN THE MINIMUM STRENGTH SPECIFIED BELOW:
 - A. WOOD – MINIMUM SPECIFIC GRAVITY OF G=0.42
 - B. CONCRETE – MINIMUM COMPRESSIVE STRENGTH OF 3,192 PSI.
 - C. MASONRY – STRENGTH CONFORMANCE TO ASTM C-90, GRADE N, TYPE 1 (OR GREATER).

SIGNED: 05/14/2013

TABLE OF CONTENTS	
SHEET NO.	DESCRIPTION
1	ELEVATION AND NOTES
2	INSTALLATION DETAILS
3	B.O.M. AND COMPONENTS

GALLINA USA, LLC 4335 CAPITAL CIRCLE JANESVILLE, WI 53545		
5/8" HURRICANE STORM PANEL RDC WITH TRACK 60 x 72 ELEVATION AND NOTES		
DRAWN: V.L.	DWG NO. 08-02017	REV -
SCALE NTS	DATE 05/14/13	SHEET 1 OF 3

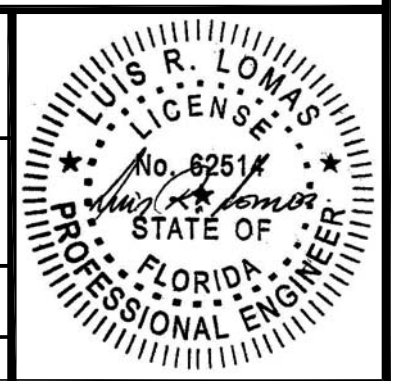

REVISIONS			
REV	DESCRIPTION	DATE	APPROVED

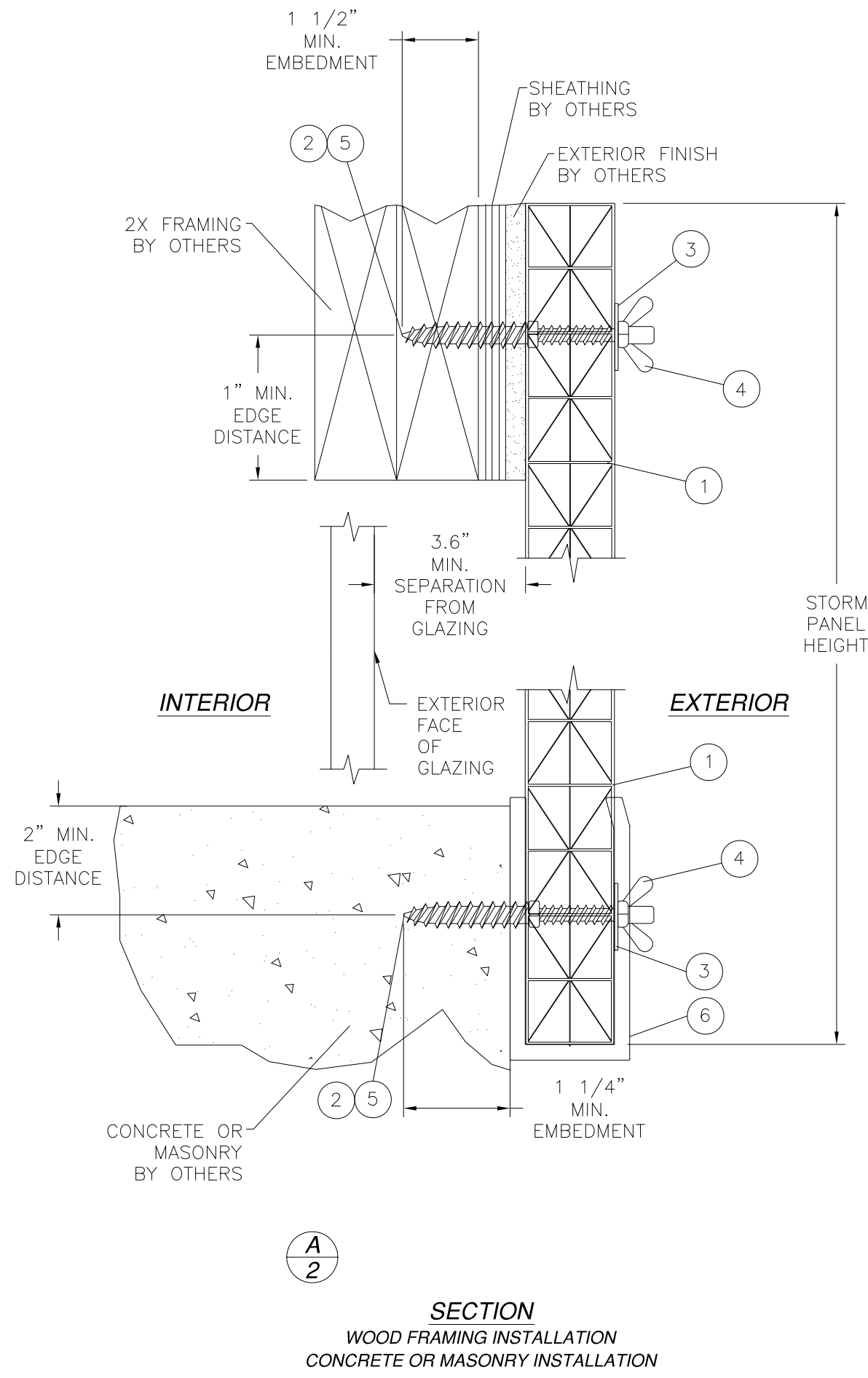

A
2

SECTION
WOOD FRAMING INSTALLATION
CONCRETE OR MASONRY INSTALLATION

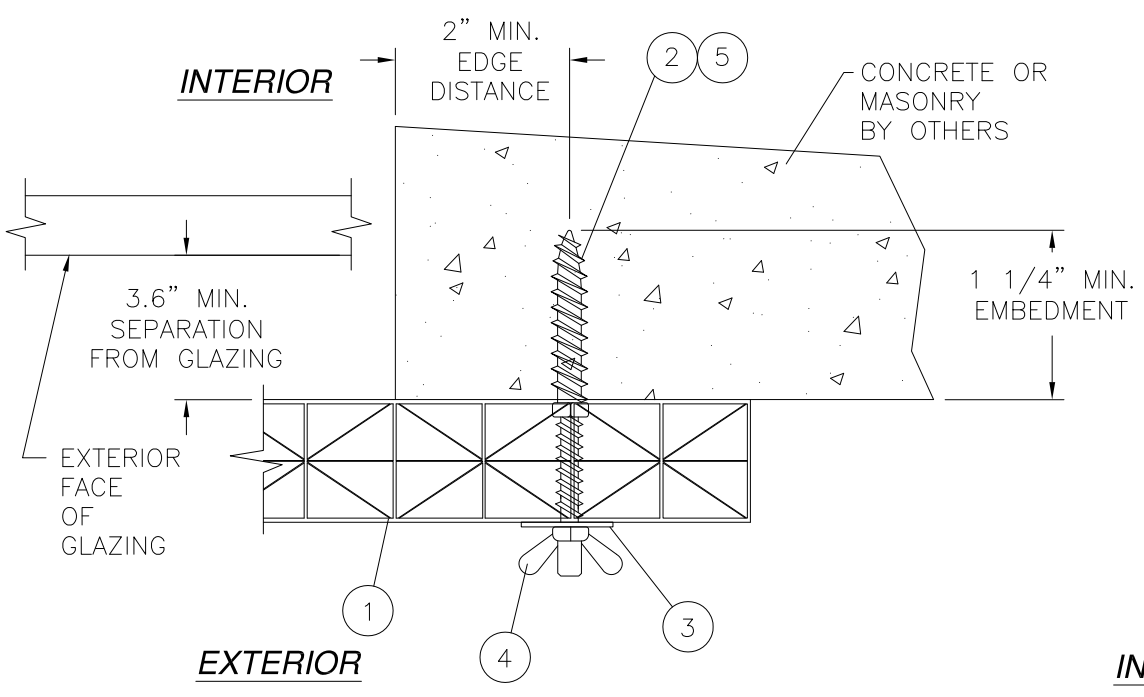

B
2

SECTION
CONCRETE OR MASONRY INSTALLATION

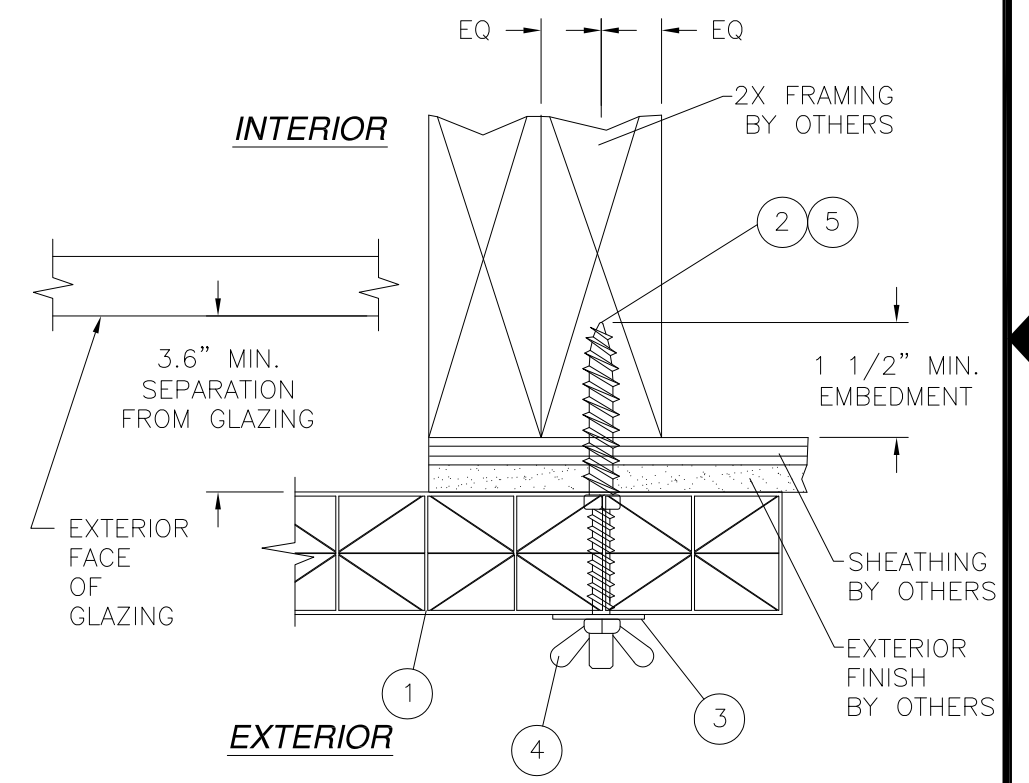

B
2

SECTION
WOOD FRAMING INSTALLATION

SIGNED: 05/14/2013

GALLINA USA, LLC
4335 CAPITAL CIRCLE
JANESVILLE, WI 53545

5/8" HURRICANE STORM PANEL RDC WITH TRACK
60 x 72
INSTALLATION DETAILS

DRAWN: V.L.	DWG NO. 08-02017	REV -
SCALE NTS	DATE 05/14/13	SHEET 2 OF 3

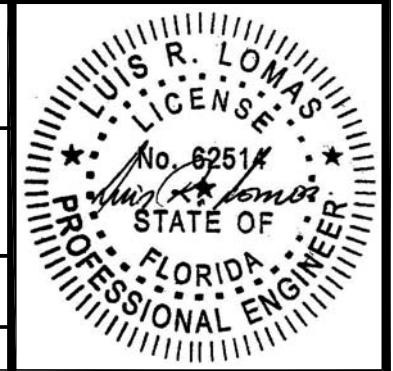

BILL OF MATERIALS				
ITEM NO.:	PART NUMBER	DESCRIPTION	MANUFACTURER	MATERIAL
1	2161	5/8" STORM PANEL		POLYCARBONATE
2	PURCHASE	1/4" PANEL MATE MALE FASTENER	TEXTRON	
3	PURCHASE	1/4" WASHER		STEEL
4	PURCHASE	1/4-20 WINGNUT		STEEL
5	PURCHASE	1/4" TAPCON SG	ITW BUILDEX	
6		U-CHANNEL	GALLINA	ALUMINUM 6063-T5

REVISIONS			
REV	DESCRIPTION	DATE	APPROVED

5/8" PRODUCT PROPERTIES			
TEST DESCRIPTION	TEST METHOD	TEST RESULTS	
SELF IGNITION TEMP.	ASTM D1929	896°F	
AVERAGE TIME OF BURNING	ASTM D635	CC-1	
STANDARD FLAME SPREAD	ASTM E84	15	
SMOKE DENSITY DEVELOPED	ASTM E84	350	
TENSILE STRENGTH (MEAN)	ASTM D638	6890 PSI	7197 PSI
		BEFORE	AFTER

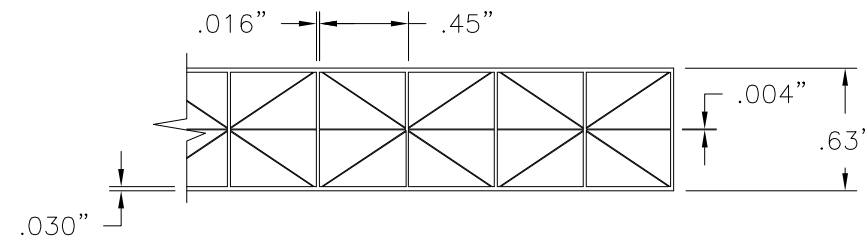

① **5/8" PANEL**
EXTERIOR WALLS 0.030"
INTERIOR FLUTED WALLS THICKNESS 0.016"



② **1/4" PANEL MATE (TEXTRON)**

⑤ **1/4" TAPCON SG (ITW BUILDEX)**



④ **1/4"-20 WING NUT**
STEEL

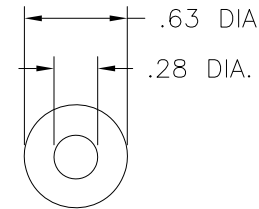

③ **1/4" WASHER**
STEEL 1/16" THICK

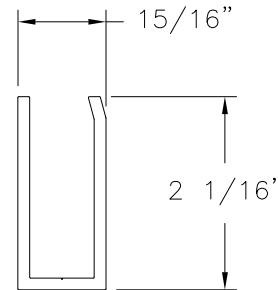

⑥ **U-CHANNEL**
ALUMINUM 6063-T5 1/8" THICK

SIGNED: 05/14/2013

GALLINA USA, LLC 4335 CAPITAL CIRCLE JANESVILLE, WI 53545		
5/8" HURRICANE STORM PANEL RDC WITH TRACK 60 x 72 B.O.M. AND COMPONENTS		
DRAWN: V.L.	DWG NO. 08-02017	REV -
SCALE NTS	DATE 05/14/13	SHEET 3 OF 3

