

| REVISIONS |                              |            |          |
|-----------|------------------------------|------------|----------|
| REV       | DESCRIPTION                  | DATE       | APPROVED |
| A         | REVISED INSTALLATION DETAILS | 05/13/2015 | R.L.     |

NOTES:

1. THE PRODUCT SHOWN HEREIN IS DESIGNED AND MANUFACTURED TO COMPLY WITH REQUIREMENTS OF THE FLORIDA BUILDING CODE.
2. WOOD FRAMING AND MASONRY OPENING TO BE DESIGNED AND ANCHORED TO PROPERLY TRANSFER ALL LOADS TO STRUCTURE. FRAMING AND MASONRY OPENING IS THE RESPONSIBILITY OF THE ARCHITECT OR ENGINEER OF RECORD.
3. 1X BUCK OVER MASONRY/CONCRETE IS OPTIONAL. WHERE 1X BUCK IS NOT USED DISSIMILAR MATERIALS MUST BE SEPARATED WITH APPROVED COATING OR MEMBRANE. SELECTION OF COATING OR MEMBRANE IS THE RESPONSIBILITY OF THE ARCHITECT OR ENGINEER OF RECORD.
4. ALLOWABLE STRESS INCREASE OF 1/3 WAS NOT USED IN THE DESIGN OF THE PRODUCT SHOWN HEREIN. WIND LOAD DURATION FACTOR Cd=1.6 WAS USED FOR WOOD ANCHOR CALCULATIONS.
5. FRAME MATERIAL: EXTRUDED ALUMINUM 6063-T5.
6. UNITS MUST BE GLAZED PER ASTM E1300-04, WITH TEMPERED GLASS
7. APPROVED IMPACT PROTECTIVE SYSTEM IS REQUIRED FOR THIS PRODUCT IN WIND BORNE DEBRIS REGIONS.
8. SHIM AS REQUIRED AT EACH INSTALLATION ANCHOR WITH LOAD BEARING SHIM. SHIM WHERE SPACE OF 1/16" OR GREATER OCCURS. MAXIMUM ALLOWABLE SHIM STACK TO BE 1/2".
9. FOR ANCHORING INTO WOOD FRAMING OR 2X BUCK USE #12 WOOD SCREWS WITH SUFFICIENT LENGTH TO ACHIEVE A 1 5/8" MINIMUM EMBEDMENT INTO SUBSTRATE. LOCATE ANCHORS AS SHOWN IN ELEVATIONS AND INSTALLATION DETAILS.
10. FOR ANCHORING INTO MASONRY/CONCRETE USE 1/4" TAPCONS WITH SUFFICIENT LENGTH TO ACHIEVE A 1 1/4" MINIMUM EMBEDMENT INTO SUBSTRATE WITH 2 1/2" MINIMUM EDGE DISTANCE. LOCATE ANCHORS AS SHOWN IN ELEVATIONS AND INSTALLATION DETAILS.
11. FOR ANCHORING INTO METAL STRUCTURE USE #12 SMS OR SELF DRILLING SCREWS WITH SUFFICIENT LENGTH TO ACHIEVE 3 THREADS MINIMUM BEYOND STRUCTURE INTERIOR WALL. LOCATE ANCHORS AS SHOWN IN ELEVATIONS AND INSTALLATION DETAILS.
12. ALL FASTENERS TO BE CORROSION RESISTANT.
13. INSTALLATION ANCHORS SHALL BE INSTALLED IN ACCORDANCE WITH ANCHOR MANUFACTURER'S INSTALLATION INSTRUCTIONS AND ANCHORS SHALL NOT BE USED IN SUBSTRATES WITH STRENGTHS LESS THAN THE MINIMUM STRENGTH SPECIFIED BELOW:
  - A. WOOD - MINIMUM SPECIFIC GRAVITY OF G=0.42
  - B. CONCRETE - MINIMUM COMPRESSIVE STRENGTH OF 3,192 PSI.
  - C. MASONRY - STRENGTH CONFORMANCE TO ASTM C-90, GRADE N, TYPE 1 (OR GREATER).
  - D. METAL STRUCTURE: STEEL 18GA, 33KSI OR ALUMINUM 6063-T5 1/8" THICK MINIMUM

SIGNED: 05/14/2015

| TABLE OF CONTENTS |                      |
|-------------------|----------------------|
| SHEET NO.         | DESCRIPTION          |
| 1                 | NOTES                |
| 2                 | ELEVATION, AND CHART |
| 3 - 4             | INSTALLATION DETAILS |

|   |                     |              |
|---|---------------------|--------------|
| <b>US ALUMINUM</b><br>DIVISION OF C.R. LAURENCE CO., INC.<br>720 CEL-RIVER RD., ROCK HILL, SC 29730 |                     |              |
| SERIES 850 SLUMINUM SINGLE DOOR<br>48" X 98" PANEL<br>NOTES   |                     |              |
| DRAWN:<br>AP  | DWG NO.<br>08-01841 | REV<br>A     |
| SCALE NTS   | DATE 10/01/12       | SHEET 1 OF 4 |

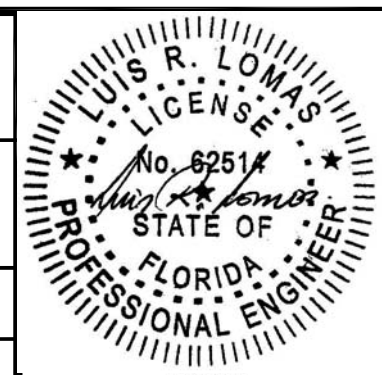

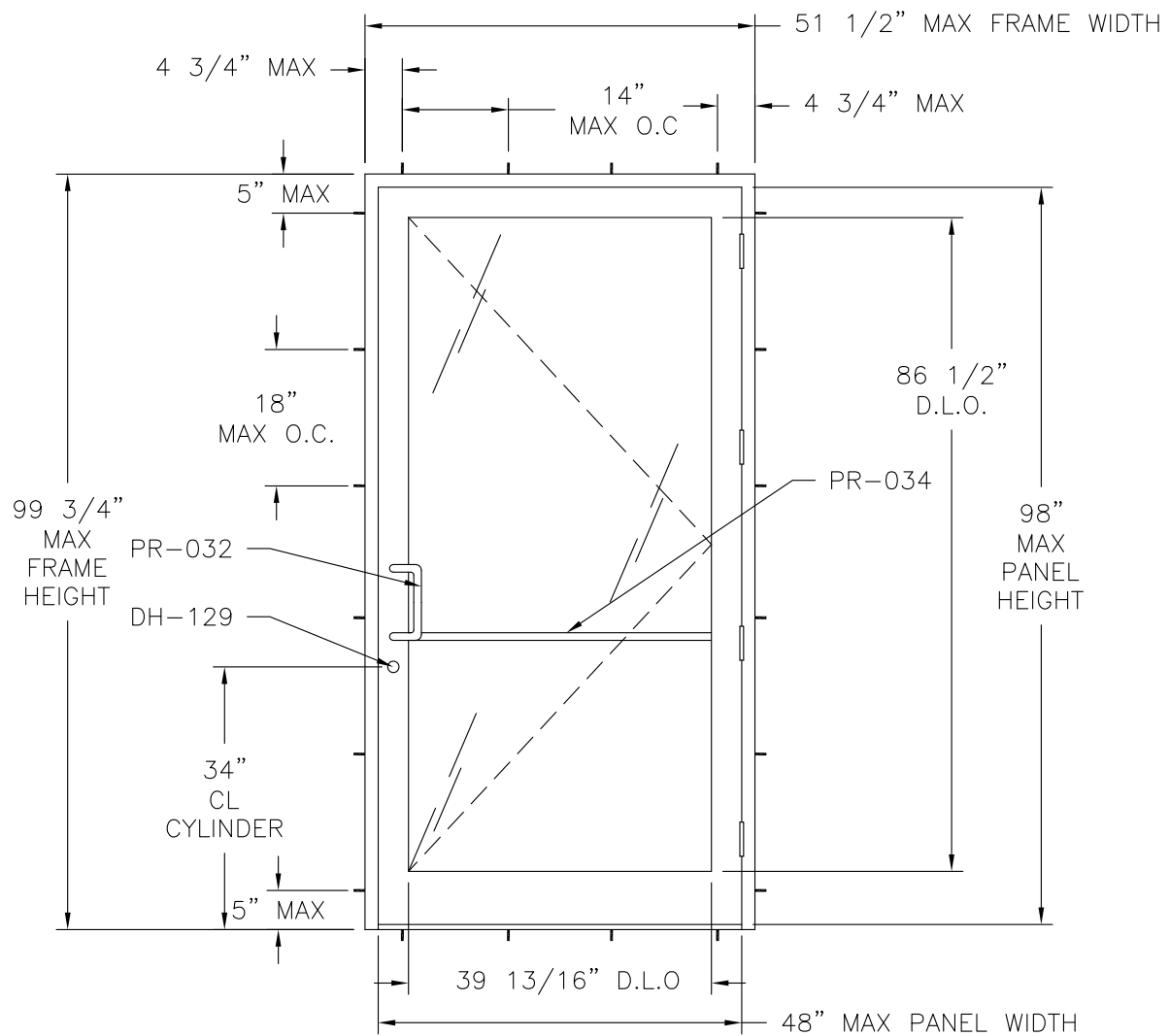

**SERIES 850 SLUMINUM SINGLE DOOR**  
**EXTERIOR VIEW FRAME FLUSH INSTALLATION**

|   |               |
|---|---------------|
| DESIGN PRESSURE RATING  | IMPACT RATING |
| ±31.0PSF  | NONE          |
| THIS SYSTEM WAS NOT TESTED FOR WATER INFILTRATION AND IS TO BE INSTALLED ONLY WHERE THE WATER REQUIREMENT IS NOT NEEDED |               |

| REVISIONS |                              |            |          |
|-----------|------------------------------|------------|----------|
| REV       | DESCRIPTION                  | DATE       | APPROVED |
| A         | REVISED INSTALLATION DETAILS | 05/13/2015 | R.L.     |

**Maximum design pressure capacity chart (psf)**

| Panel Height (in) | Panel width (in) |      |      |      |      |      |      |      |      |      |      |      |
|-------------------|------------------|------|------|------|------|------|------|------|------|------|------|------|
|                   | 28.0             |      | 32.0 |      | 36.0 |      | 40.0 |      | 44.0 |      | 48.0 |      |
|                   | Pos              | Neg  | Pos  | Neg  | Pos  | Neg  | Pos  | Neg  | Pos  | Neg  | Pos  | Neg  |
| 78.0              | 48.9             | 48.9 | 44.2 | 44.2 | 40.6 | 40.6 | 37.8 | 37.8 | 35.6 | 35.6 | 33.8 | 33.8 |
| 80.0              | 48.6             | 48.6 | 43.9 | 43.9 | 40.3 | 40.3 | 37.5 | 37.5 | 35.2 | 35.2 | 33.4 | 33.4 |
| 82.0              | 48.4             | 48.4 | 43.6 | 43.6 | 40.0 | 40.0 | 37.2 | 37.2 | 34.9 | 34.9 | 33.1 | 33.1 |
| 84.0              | 48.2             | 48.2 | 43.4 | 43.4 | 39.7 | 39.7 | 36.9 | 36.9 | 34.6 | 34.6 | 32.8 | 32.8 |
| 86.0              | 47.9             | 47.9 | 43.1 | 43.1 | 39.5 | 39.5 | 36.6 | 36.6 | 34.3 | 34.3 | 32.5 | 32.5 |
| 88.0              | 47.7             | 47.7 | 42.9 | 42.9 | 39.2 | 39.2 | 36.4 | 36.4 | 34.0 | 34.0 | 32.2 | 32.2 |
| 90.0              | 47.5             | 47.5 | 42.7 | 42.7 | 39.0 | 39.0 | 36.1 | 36.1 | 33.8 | 33.8 | 31.9 | 31.9 |
| 92.0              | 47.3             | 47.3 | 42.5 | 42.5 | 38.8 | 38.8 | 35.9 | 35.9 | 33.6 | 33.6 | 31.7 | 31.7 |
| 94.0              | 47.2             | 47.2 | 42.3 | 42.3 | 38.6 | 38.6 | 35.7 | 35.7 | 33.3 | 33.3 | 31.4 | 31.4 |
| 96.0              | 47.0             | 47.0 | 42.1 | 42.1 | 38.4 | 38.4 | 35.5 | 35.5 | 33.1 | 33.1 | 31.2 | 31.2 |
| 98.0              | 46.8             | 46.8 | 42.0 | 42.0 | 38.2 | 38.2 | 35.3 | 35.3 | 32.9 | 32.9 | 31.0 | 31.0 |

**HARDWARE SCHEDULE**

|  |
|--|
| A. PR-032 PULL HANDLE                          |
| B. PR-034 PUSH BAR                             |
| C. DH-129 HOOK BOLT LOCK                       |
| D. (4) DH-009 FIVE BARREL STAINLES STEEL HINGE |

SIGNED: 05/14/2015

**US ALUMINUM**  
 DIVISION OF C.R. LAURENCE CO., INC.  
 720 CEL-RIVER RD., ROCK HILL, SC 29730

SERIES 850 SLUMINUM SINGLE DOOR  
 48" X 98" PANEL  
 NOTES

|              |                     |              |
|--------------|---------------------|--------------|
| DRAWN:<br>AP | DWG NO.<br>08-01841 | REV<br>A     |
| SCALE NTS    | DATE 10/01/12       | SHEET 2 OF 4 |

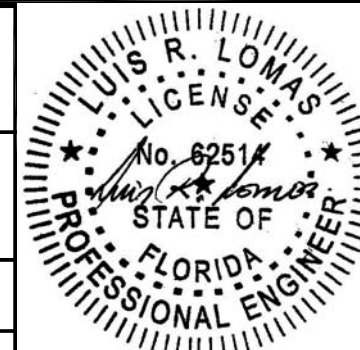

| REVISIONS |                              |            |          |
|-----------|------------------------------|------------|----------|
| REV       | DESCRIPTION                  | DATE       | APPROVED |
| A         | REVISED INSTALLATION DETAILS | 05/13/2015 | R.L.     |

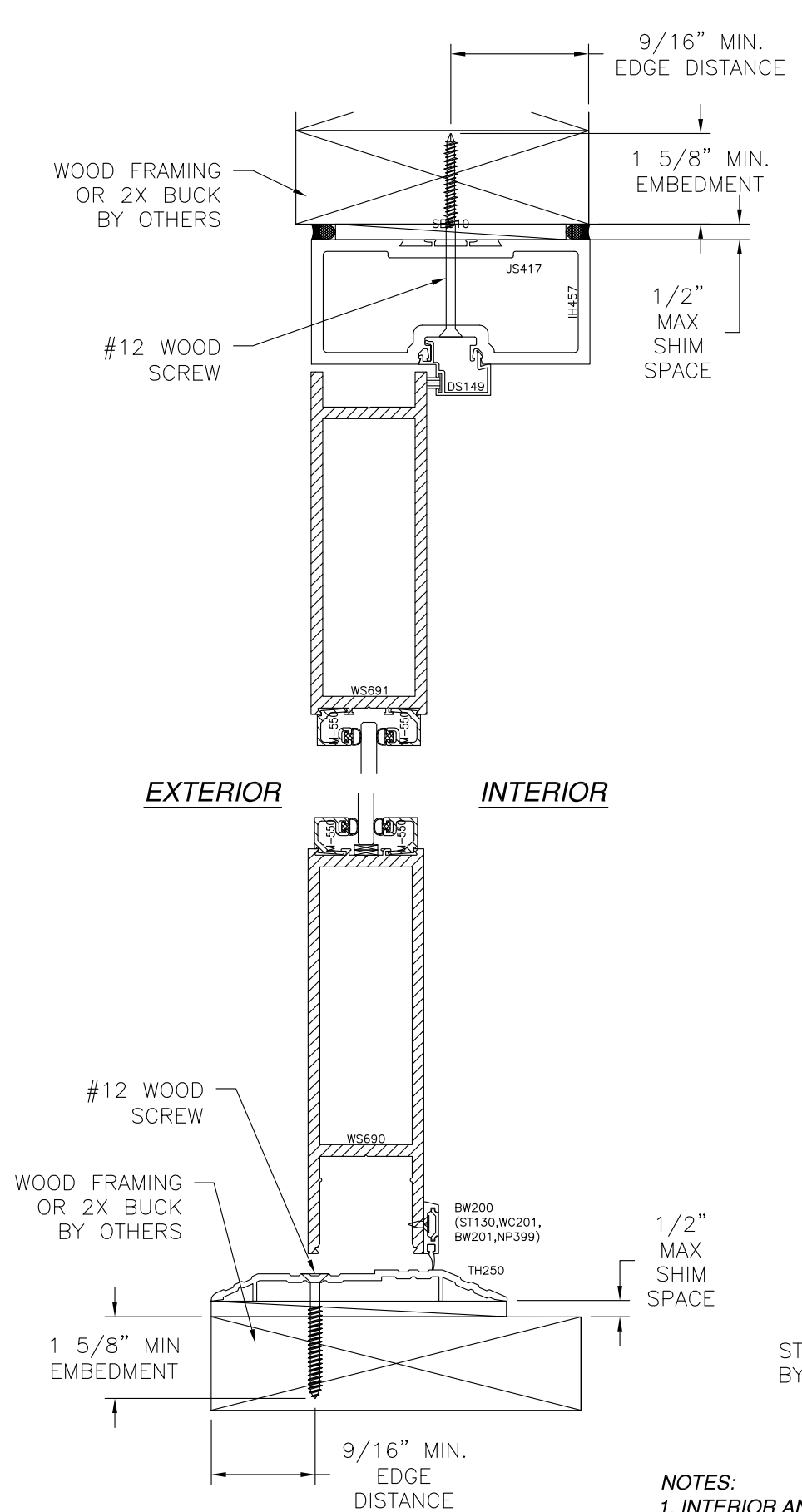

**VERTICAL CROSS SECTION**  
WOOD FRAMING OR 2X BUCK INSTALLATION

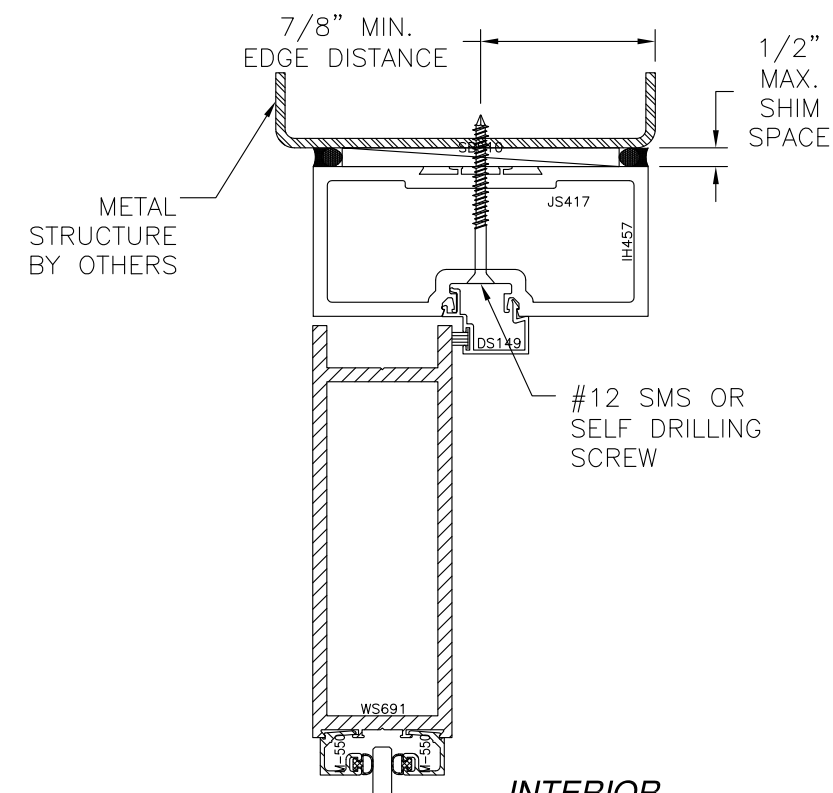

**VERTICAL CROSS SECTION**  
METAL STRUCTURE INSTALLATION

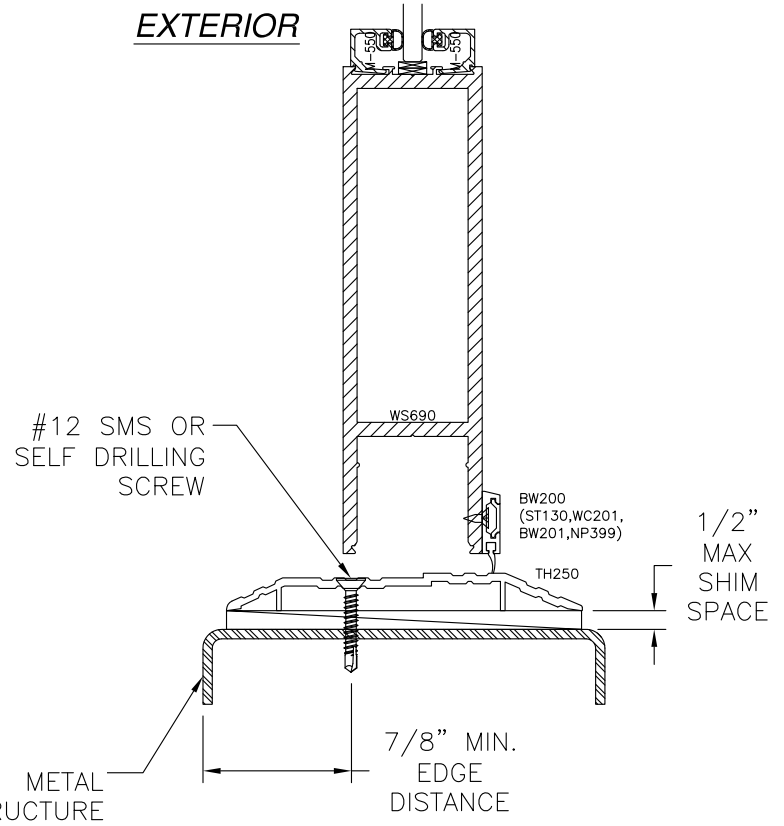

**VERTICAL CROSS SECTION**  
WOOD FRAMING OR 2X BUCK INSTALLATION

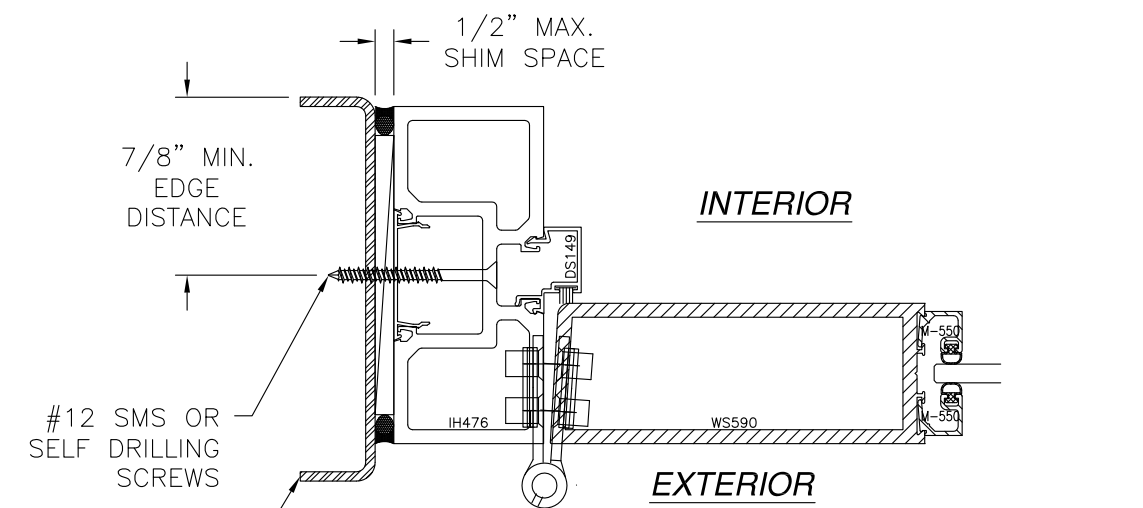

**JAMB INSTALLATION DETAIL**  
METAL STRUCTURE INSTALLATION

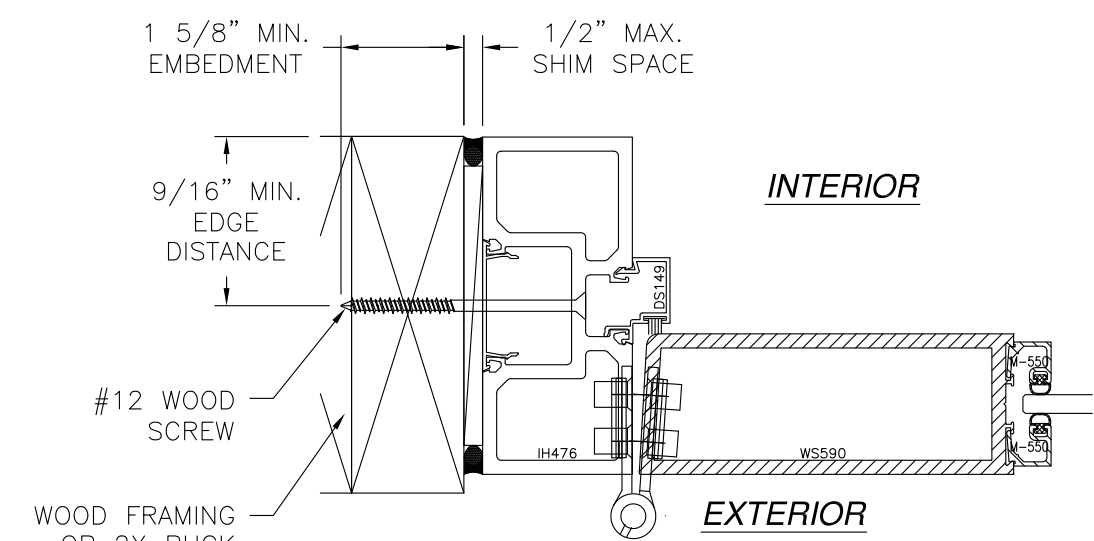

**JAMB INSTALLATION DETAIL**  
WOOD FRAMING OR 2X BUCK INSTALLATION

- NOTES:**
1. INTERIOR AND EXTERIOR FINISHES, BY OTHERS, NOT SHOWN FOR CLARITY.
  2. PERIMETER AND JOINT SEALANT BY OTHERS TO BE DESIGNED IN ACCORDANCE WITH ASTM E2112

SIGNED: 05/14/2015

|   |                     |                 |
|---|---------------------|-----------------|
| <b>US ALUMINUM</b><br>DIVISION OF C.R. LAURENCE CO., INC.<br>720 CEL-RIVER RD., ROCK HILL, SC 29730 |                     |                 |
| SERIES 850 ALUMINUM SINGLE DOOR<br>48" X 98" PANEL<br>INSTALLATION DETAILS                          |                     |                 |
| DRAWN:<br>AP  | DWG NO.<br>08-01841 | REV<br>A        |
| SCALE<br>NTS  | DATE<br>10/01/12    | SHEET<br>3 OF 4 |

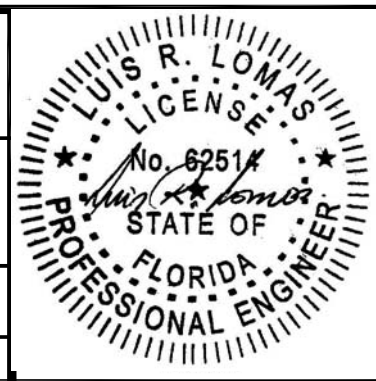

| REVISIONS |                              |            |          |
|-----------|------------------------------|------------|----------|
| REV       | DESCRIPTION                  | DATE       | APPROVED |
| A         | REVISED INSTALLATION DETAILS | 05/13/2015 | R.L.     |

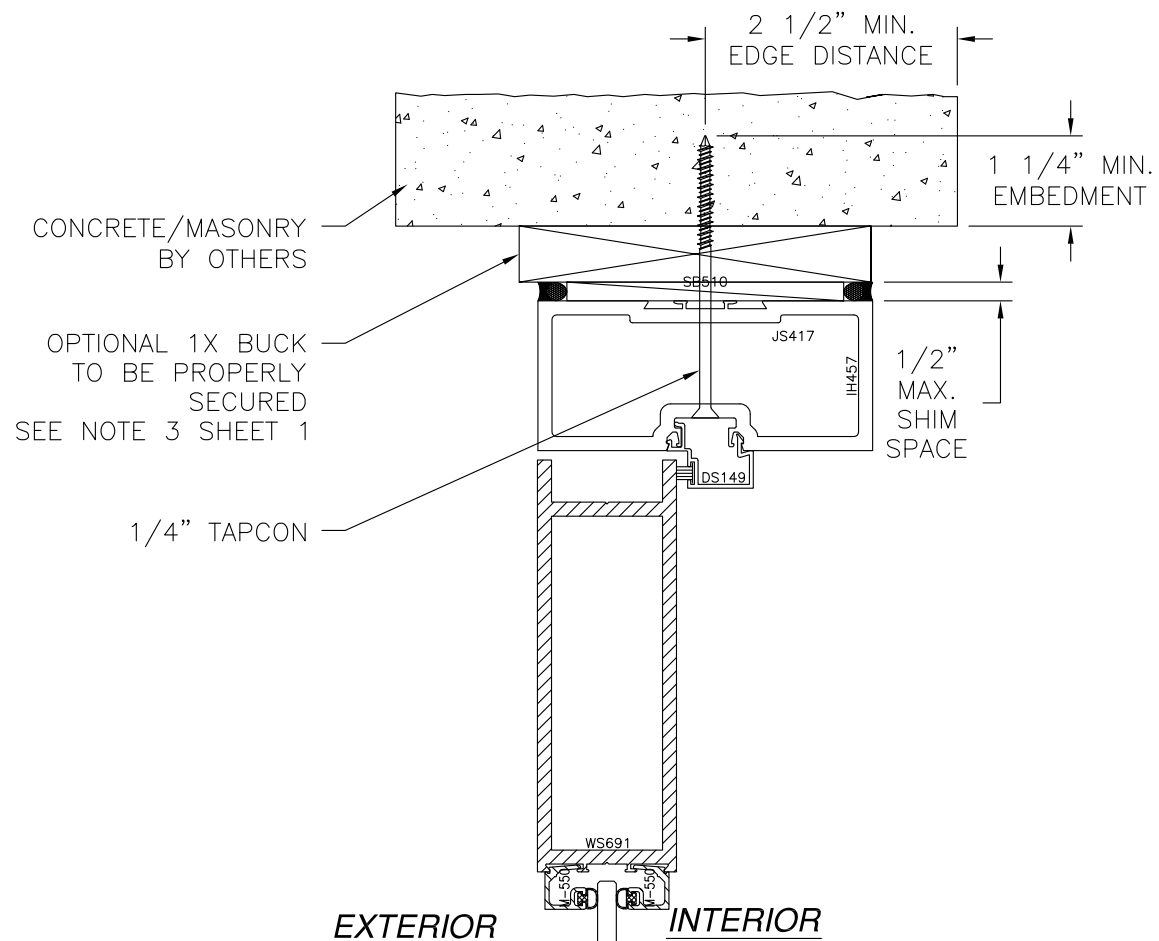

EXTERIOR INTERIOR

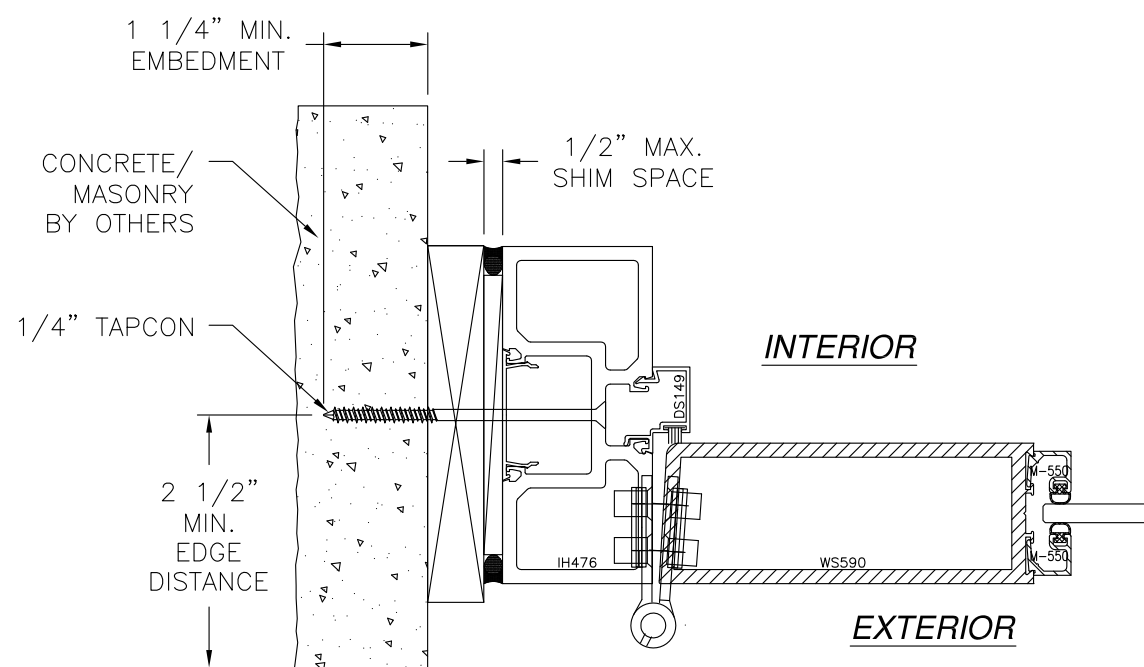

**JAMB INSTALLATION DETAIL**  
CONCRETE/MASONRY INSTALLATION

- NOTES:**
1. INTERIOR AND EXTERIOR FINISHES, BY OTHERS, NOT SHOWN FOR CLARITY.
  2. PERIMETER AND JOINT SEALANT BY OTHERS TO BE DESIGNED IN ACCORDANCE WITH ASTM E2112

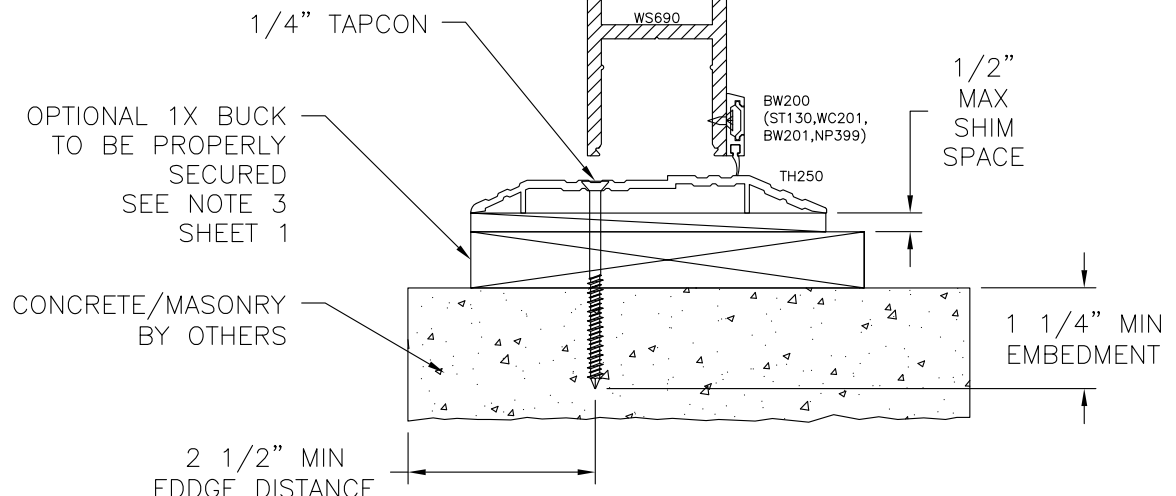

**VERTICAL CROSS SECTION**  
CONCRETE/MASONRY INSTALLATION

SIGNED: 05/14/2015

|   |                     |              |
|---|---------------------|--------------|
| <b>US ALUMINUM</b><br>DIVISION OF C.R. LAURENCE CO., INC.<br>720 CEL-RIVER RD., ROCK HILL, SC 29730 |                     |              |
| SERIES 850 SLUMINUM SINGLE DOOR<br>48" X 98" PANEL<br>INSTALLATION DETAILS                          |                     |              |
| DRAWN:<br>AP  | DWG NO.<br>08-01841 | REV<br>A     |
| SCALE NTS   | DATE 10/01/12       | SHEET 4 OF 4 |

