

REVISIONS			
REV	DESCRIPTION	DATE	APPROVED
A	REVISED INSTALLATION DETAILS	05/11/15	R.L.

NOTES:

1. THE PRODUCT SHOWN HEREIN IS DESIGNED AND MANUFACTURED TO COMPLY WITH REQUIREMENTS OF THE FLORIDA BUILDING CODE.
2. WOOD FRAMING AND MASONRY OPENING TO BE DESIGNED AND ANCHORED TO PROPERLY TRANSFER ALL LOADS TO STRUCTURE. FRAMING AND MASONRY OPENING IS THE RESPONSIBILITY OF THE ARCHITECT OR ENGINEER OF RECORD.
3. 1X BUCK OVER MASONRY/CONCRETE IS OPTIONAL. WHERE 1X BUCK IS NOT USED DISSIMILAR MATERIALS MUST BE SEPARATED WITH APPROVED COATING OR MEMBRANE. SELECTION OF COATING OR MEMBRANE IS THE RESPONSIBILITY OF THE ARCHITECT OR ENGINEER OF RECORD.
4. ALLOWABLE STRESS INCREASE OF 1/3 WAS NOT USED IN THE DESIGN OF THE PRODUCT SHOWN HEREIN. WIND LOAD DURATION FACTOR Cd=1.6 WAS USED FOR WOOD ANCHOR CALCULATIONS.
5. FRAME MATERIAL: EXTRUDED ALUMINUM 6063-T5.
6. UNITS MUST BE GLAZED PER ASTM E1300-04, WITH TEMPERED GLASS
7. APPROVED IMPACT PROTECTIVE SYSTEM IS REQUIRED FOR THIS PRODUCT IN WIND BORNE DEBRIS REGIONS.
8. SHIM AS REQUIRED AT EACH INSTALLATION ANCHOR WITH LOAD BEARING SHIM. SHIM WHERE SPACE OF 1/16" OR GREATER OCCURS. MAXIMUM ALLOWABLE SHIM STACK TO BE 1/2".
9. FOR ANCHORING INTO WOOD FRAMING OR 2X BUCK USE #12 WOOD SCREWS WITH SUFFICIENT LENGTH TO ACHIEVE A 1 5/8" MINIMUM EMBEDMENT INTO SUBSTRATE. LOCATE ANCHORS AS SHOWN IN ELEVATIONS AND INSTALLATION DETAILS.
10. FOR ANCHORING INTO MASONRY/CONCRETE USE 1/4" TAPCONS WITH SUFFICIENT LENGTH TO ACHIEVE A 1 1/4" MINIMUM EMBEDMENT INTO SUBSTRATE WITH 2 1/2" MINIMUM EDGE DISTANCE. LOCATE ANCHORS AS SHOWN IN ELEVATIONS AND INSTALLATION DETAILS.
11. FOR ANCHORING INTO METAL STRUCTURE USE #12 SMS OR SELF DRILLING SCREWS WITH SUFFICIENT LENGTH TO ACHIEVE 3 THREADS MINIMUM BEYOND STRUCTURE INTERIOR WALL. LOCATE ANCHORS AS SHOWN IN ELEVATIONS AND INSTALLATION DETAILS.
12. ALL FASTENERS TO BE CORROSION RESISTANT.
13. INSTALLATION ANCHORS SHALL BE INSTALLED IN ACCORDANCE WITH ANCHOR MANUFACTURER'S INSTALLATION INSTRUCTIONS AND ANCHORS SHALL NOT BE USED IN SUBSTRATES WITH STRENGTHS LESS THAN THE MINIMUM STRENGTH SPECIFIED BELOW:
  - A. WOOD - MINIMUM SPECIFIC GRAVITY OF G=0.42
  - B. CONCRETE - MINIMUM COMPRESSIVE STRENGTH OF 3,192 PSI.
  - C. MASONRY - STRENGTH CONFORMANCE TO ASTM C-90, GRADE N, TYPE 1 (OR GREATER).
  - D. METAL STRUCTURE: STEEL 18GA, 33KSI OR ALUMINUM 6063-T5 1/8" THICK MINIMUM

SIGNED: 05/11/2015

TABLE OF CONTENTS	
SHEET NO.	DESCRIPTION
1	NOTES
2	ELEVATION, AND CHART
3 - 4	INSTALLATION DETAILS

<b>US ALUMINUM</b> DIVISION OF C.R. LAURENCE CO., INC. 720 CEL-RIVER RD., ROCK HILL, SC 29730		
SERIES 400 ALUMINUM MEDIUM STILE DOOR 48" X 98" PANEL NOTES		
DRAWN: AP	DWG NO. 08-01801	REV A
SCALE NTS	DATE 10/01/12	SHEET 1 OF 4

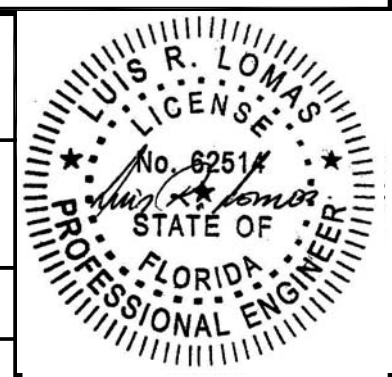

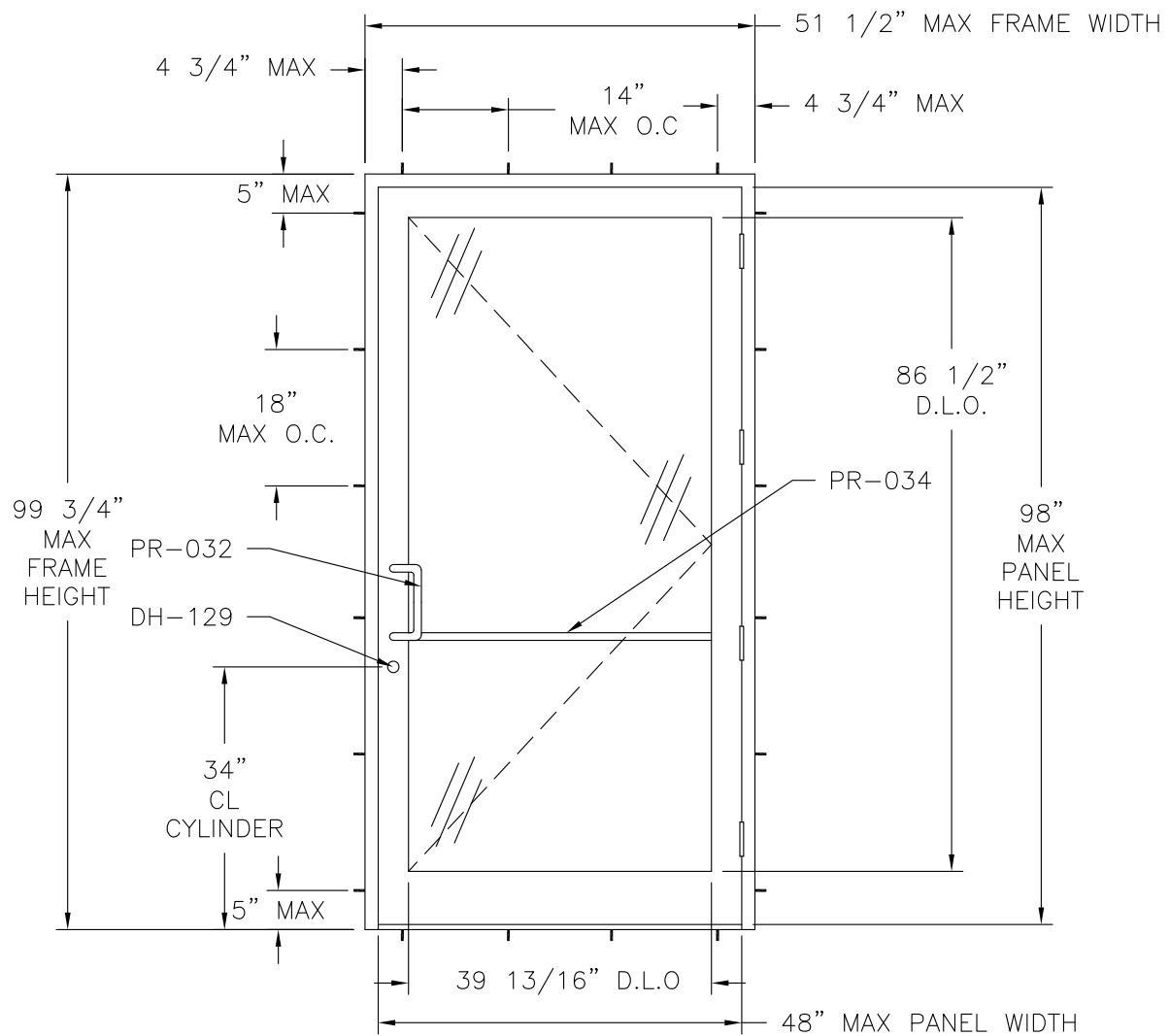

**SERIES 400 ALUMINUM MEDIUM STILE DOOR**  
EXTERIOR VIEW FRAME FLUSH INSTALLATION

DESIGN PRESSURE RATING	IMPACT RATING
±31.0PSF	NONE
THIS SYSTEM WAS NOT TESTED FOR WATER INFILTRATION AND IS TO BE INSTALLED ONLY WHERE THE WATER REQUIREMENT IS NOT NEEDED	

REVISIONS			
REV	DESCRIPTION	DATE	APPROVED
A	REVISED INSTALLATION DETAILS	05/11/15	R.L.

**Maximum design pressure capacity chart (psf)**

Panel Height (in)	Panel width (in)											
	28.0		32.0		36.0		40.0		44.0		48.0	
	Pos	Neg	Pos	Neg	Pos	Neg	Pos	Neg	Pos	Neg	Pos	Neg
78.0	48.9	48.9	44.2	44.2	40.6	40.6	37.8	37.8	35.6	35.6	33.8	33.8
80.0	48.6	48.6	43.9	43.9	40.3	40.3	37.5	37.5	35.2	35.2	33.4	33.4
82.0	48.4	48.4	43.6	43.6	40.0	40.0	37.2	37.2	34.9	34.9	33.1	33.1
84.0	48.2	48.2	43.4	43.4	39.7	39.7	36.9	36.9	34.6	34.6	32.8	32.8
86.0	47.9	47.9	43.1	43.1	39.5	39.5	36.6	36.6	34.3	34.3	32.5	32.5
88.0	47.7	47.7	42.9	42.9	39.2	39.2	36.4	36.4	34.0	34.0	32.2	32.2
90.0	47.5	47.5	42.7	42.7	39.0	39.0	36.1	36.1	33.8	33.8	31.9	31.9
92.0	47.3	47.3	42.5	42.5	38.8	38.8	35.9	35.9	33.6	33.6	31.7	31.7
94.0	47.2	47.2	42.3	42.3	38.6	38.6	35.7	35.7	33.3	33.3	31.4	31.4
96.0	47.0	47.0	42.1	42.1	38.4	38.4	35.5	35.5	33.1	33.1	31.2	31.2
98.0	46.8	46.8	42.0	42.0	38.2	38.2	35.3	35.3	32.9	32.9	31.0	31.0

**HARDWARE SCHEDULE**

A. PR-032 PULL HANDLE
B. PR-034 PUSH BAR
C. DH-129 HOOK BOLT LOCK
D. (4) DH-009 FIVE BARREL STAINLES STEEL HINGE

SIGNED: 05/11/2015

**US ALUMINUM**  
DIVISION OF C.R. LAURENCE CO., INC.  
720 CEL-RIVER RD., ROCK HILL, SC 29730

SERIES 400 ALUMINUM MEDIUM STILE DOOR  
48" X 98" PANEL  
NOTES

DRAWN: AP	DWG NO. 08-01801	REV A
SCALE NTS	DATE 10/01/12	SHEET 2 OF 4

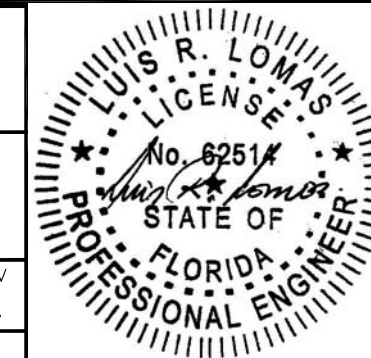

REVISIONS			
REV	DESCRIPTION	DATE	APPROVED
A	REVISED INSTALLATION DETAILS	05/11/15	R.L.

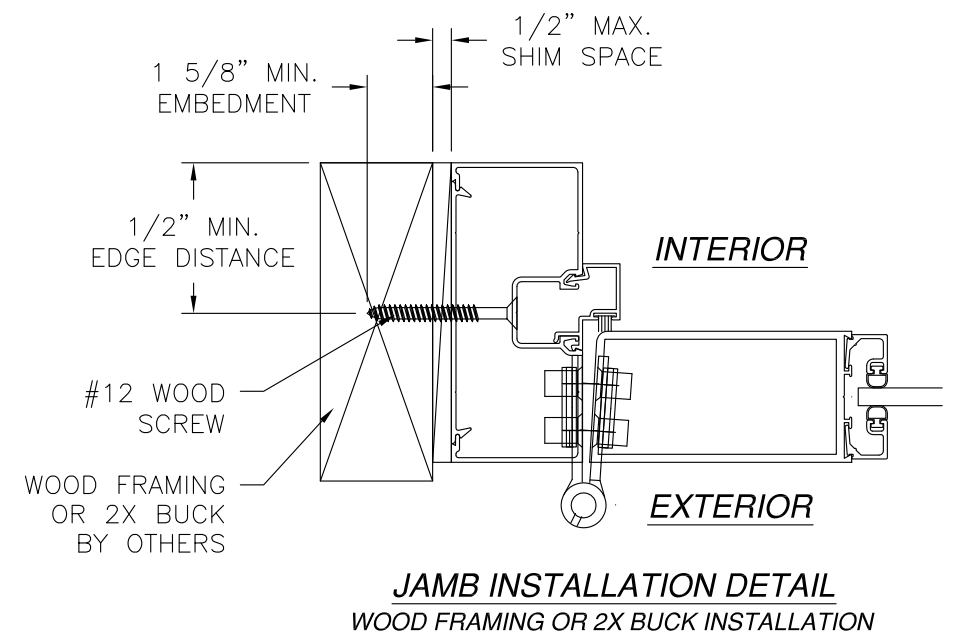
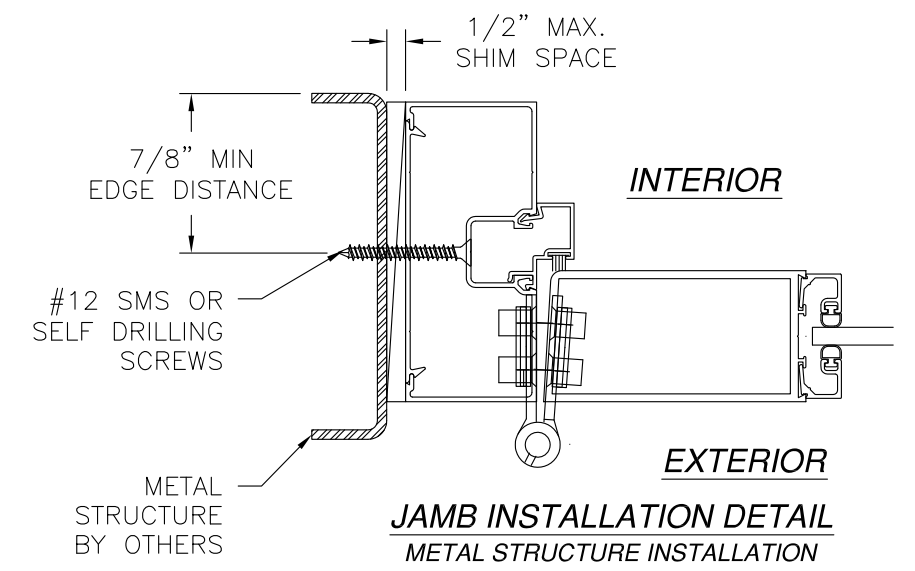
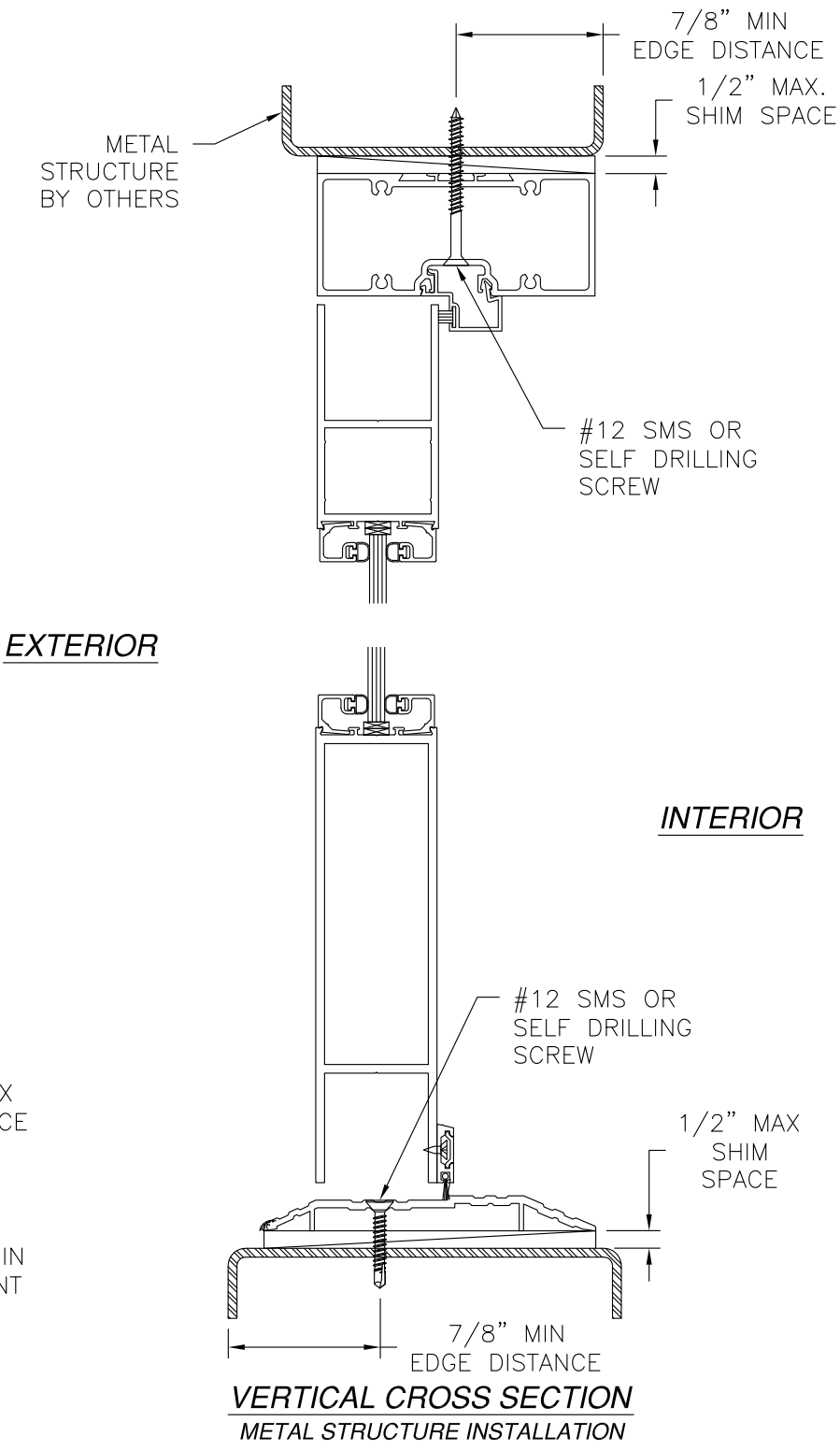
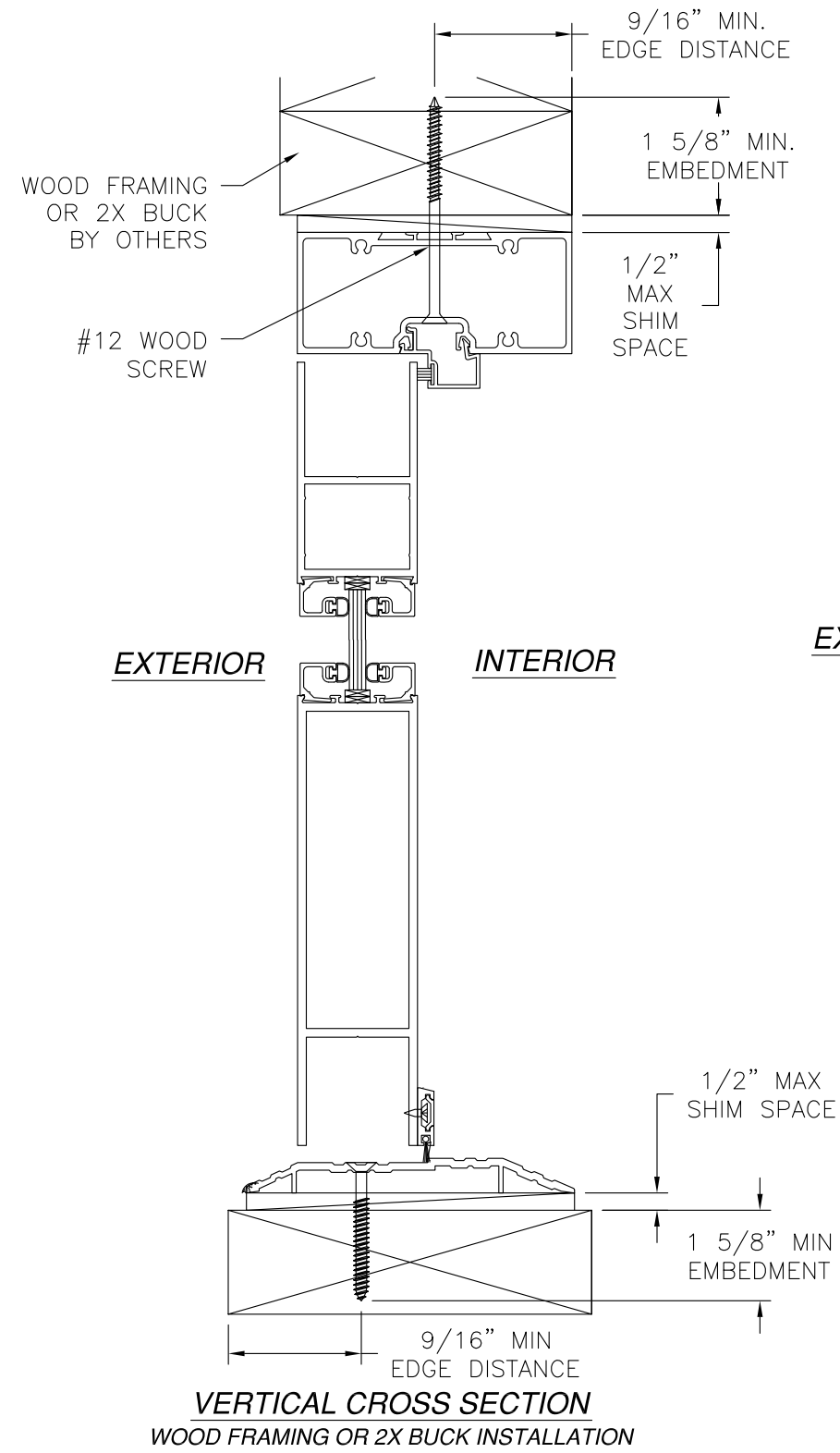

NOTES:  
 1. INTERIOR AND EXTERIOR FINISHES, BY OTHERS, NOT SHOWN FOR CLARITY.  
 2. PERIMETER AND JOINT SEALANT BY OTHERS TO BE DESIGNED IN ACCORDANCE WITH ASTM E2112

SIGNED: 05/11/2015

**US ALUMINUM**  
 DIVISION OF C.R. LAURENCE CO., INC.  
 720 CEL-RIVER RD., ROCK HILL, SC 29730

SERIES 400 ALUMINUM MEDIUM STILE DOOR  
 48" X 98" PANEL  
 INSTALLATION DETAILS

DRAWN: AP	DWG NO. 08-01801	REV A
SCALE NTS	DATE 10/01/12	SHEET 3 OF 4

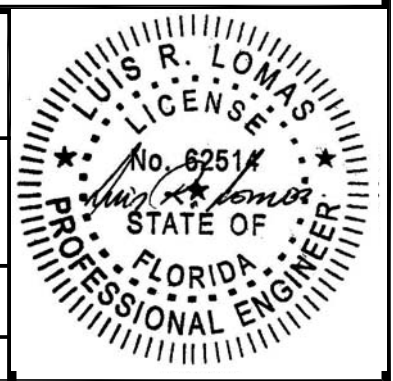

REVISIONS			
REV	DESCRIPTION	DATE	APPROVED
A	REVISED INSTALLATION DETAILS	05/11/15	R.L.

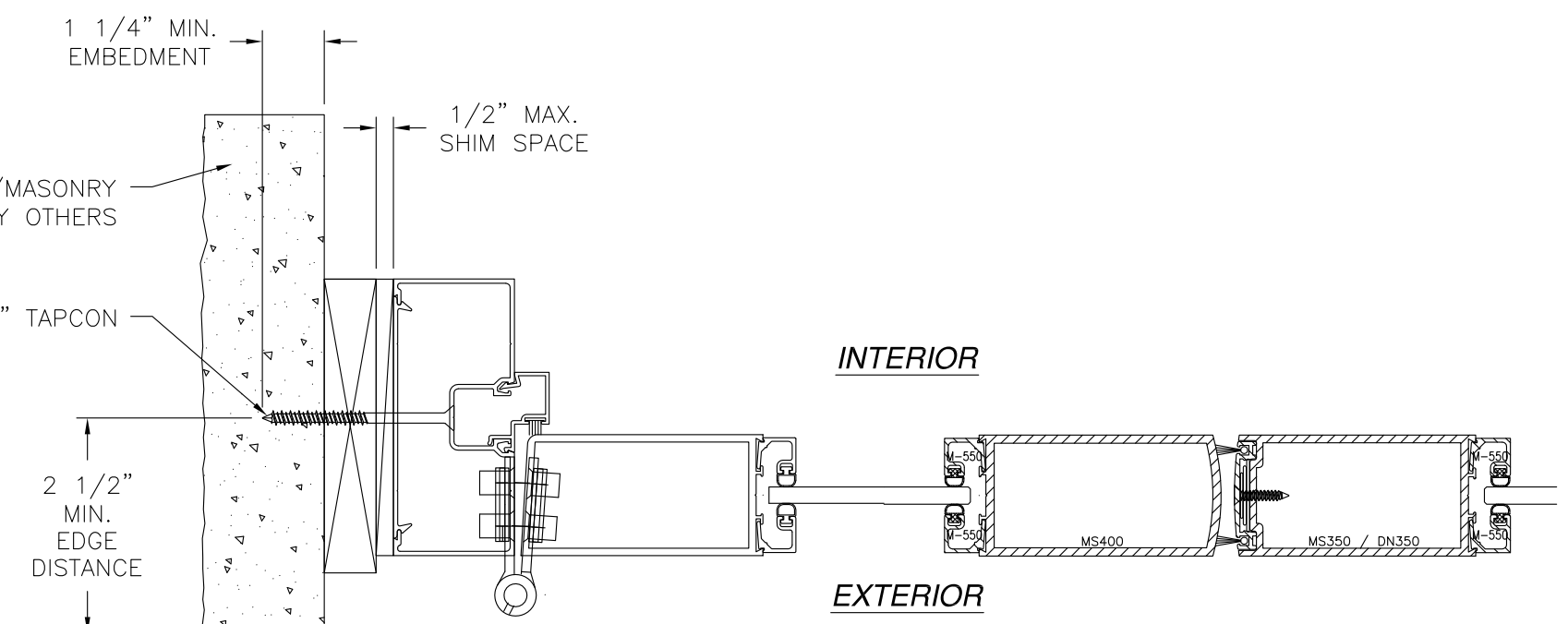
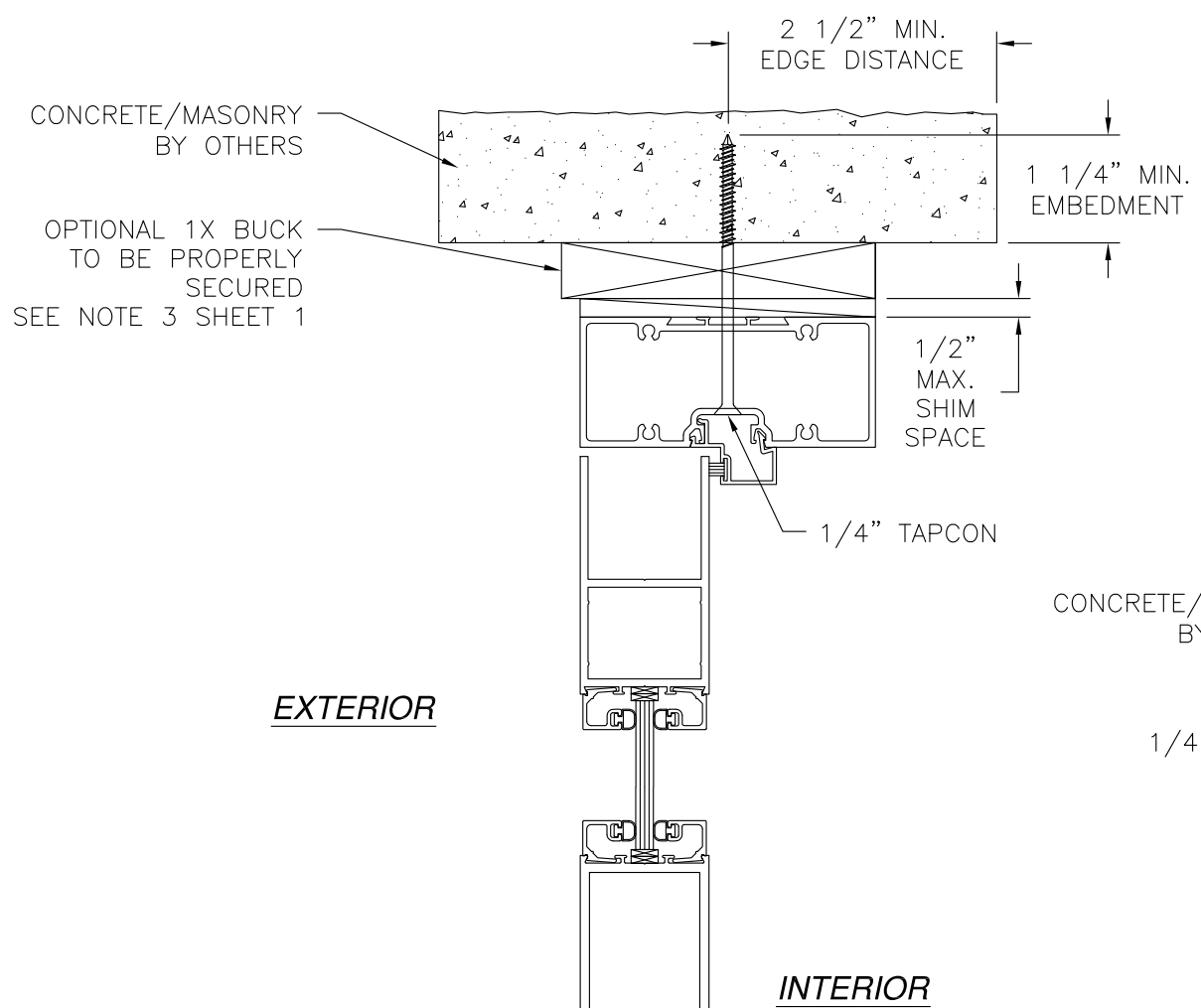

**JAMB INSTALLATION DETAIL**  
CONCRETE/MASONRY INSTALLATION

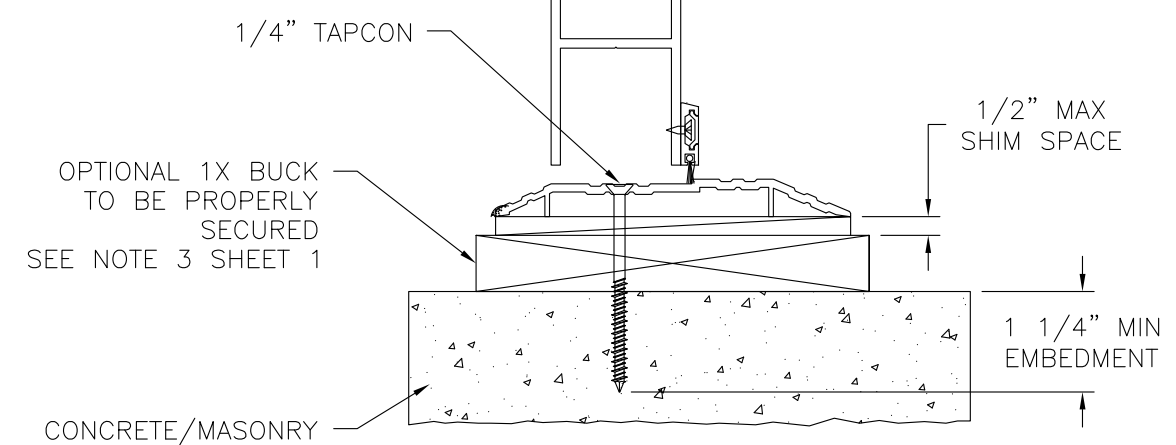

**VERTICAL CROSS SECTION**  
CONCRETE/MASONRY INSTALLATION

**NOTES:**  
 1. INTERIOR AND EXTERIOR FINISHES, BY OTHERS, NOT SHOWN FOR CLARITY.  
 2. PERIMETER AND JOINT SEALANT BY OTHERS TO BE DESIGNED IN ACCORDANCE WITH ASTM E2112

**US ALUMINUM**  
 DIVISION OF C.R. LAURENCE CO., INC.  
 720 CEL-RIVER RD., ROCK HILL, SC 29730

SERIES 400 ALUMINUM MEDIUM STILE DOOR  
 48" X 98" PANEL  
 INSTALLATION DETAILS

DRAWN: AP	DWG NO. 08-01801	REV A
SCALE NTS	DATE 10/01/12	SHEET 4 OF 4

SIGNED: 05/11/2015

