

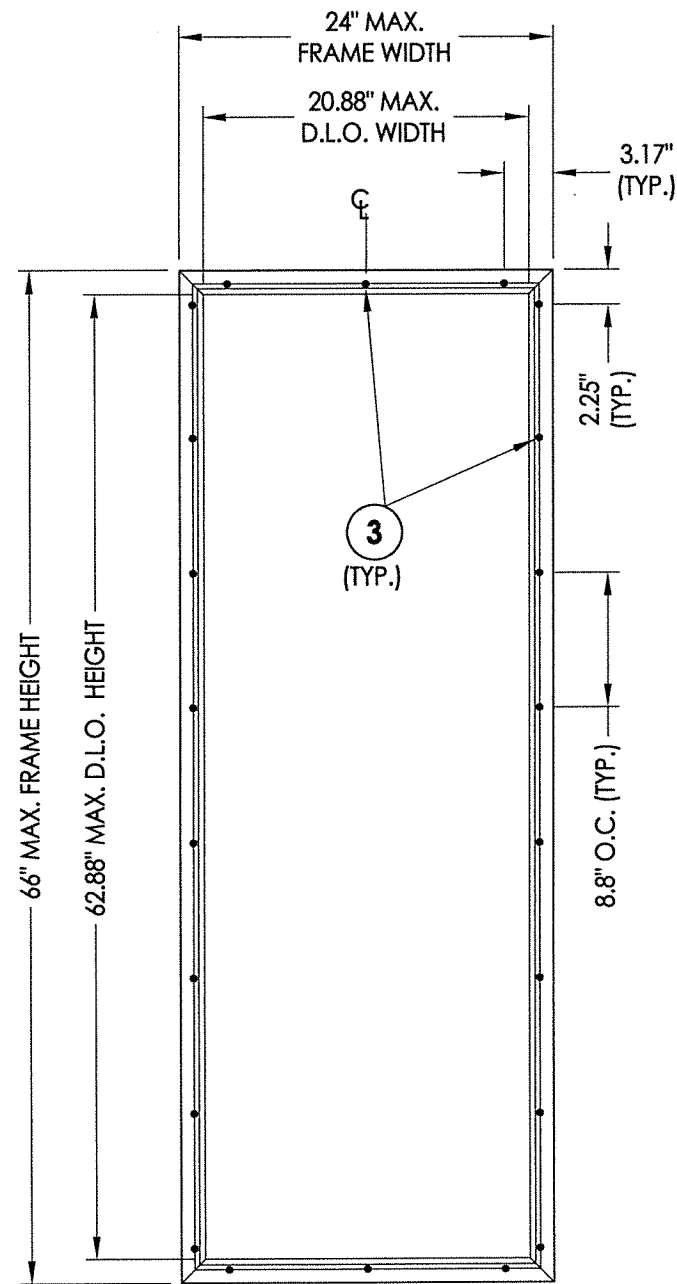

| BILL OF MATERIALS |                                    |            |
|-------------------|------------------------------------|------------|
| ITEM #            | DESCRIPTION                        | MATERIAL   |
| 1                 | INTERIOR FRAME (EVOLVE)            | HP-POLYPRO |
| 2                 | EXTERIOR FRAME (EVOLVE)            | HP-POLYPRO |
| 3                 | #8 X 1-1/2" PPH SMS (HI-LO THREAD) | STEEL      |

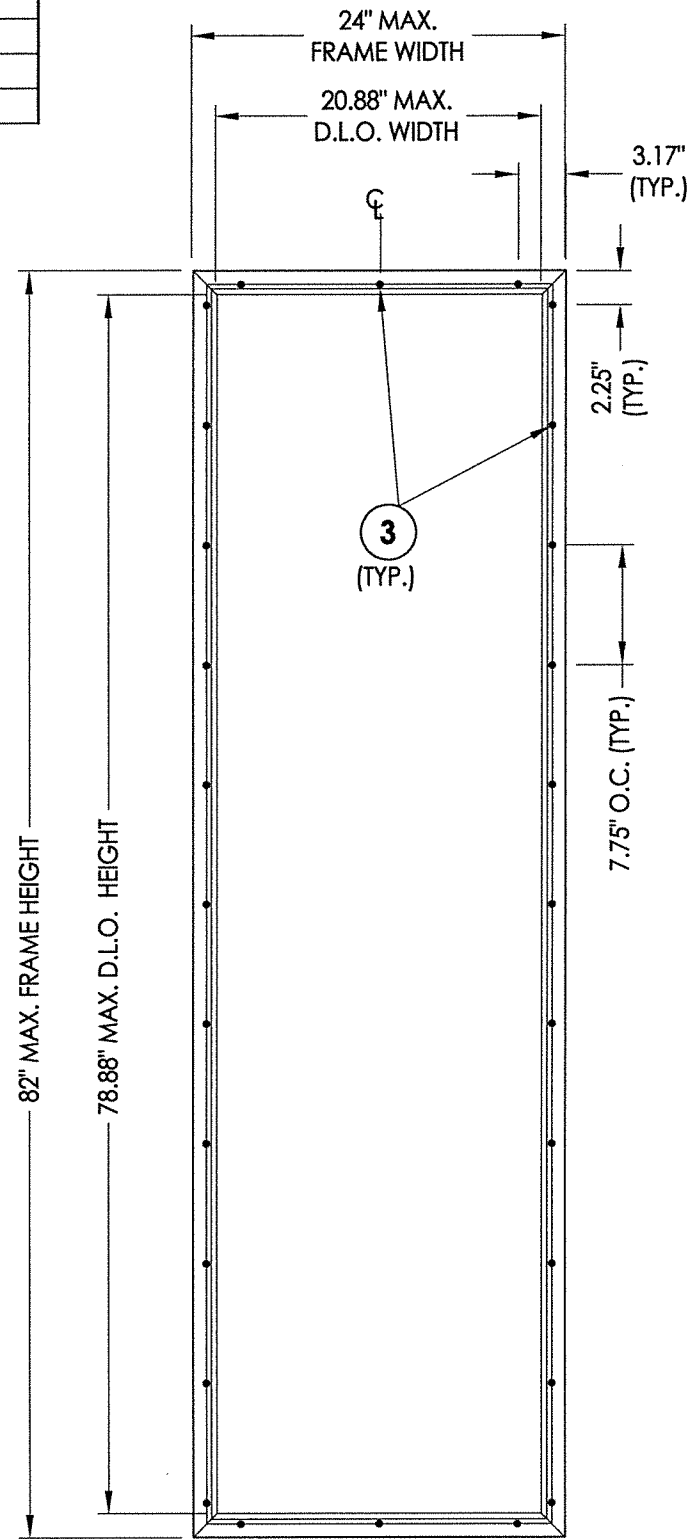

EVOLVE FRAME SYSTEM  
HP Polypropylene  
6'-8" DOOR



EVOLVE FRAME SYSTEM  
HP Polypropylene  
8'-0" DOOR

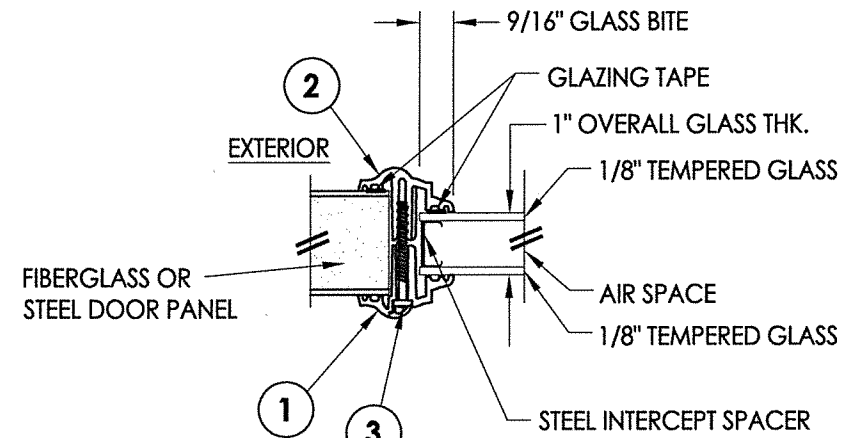
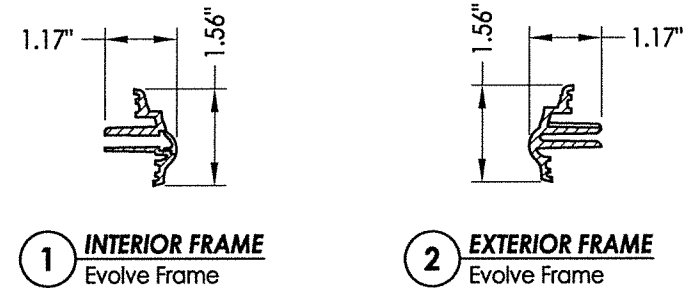

**G1 GLAZING DETAIL**  
EVOLVE FRAME (1" INSULATED GLASS)  
TAPE GLAZING

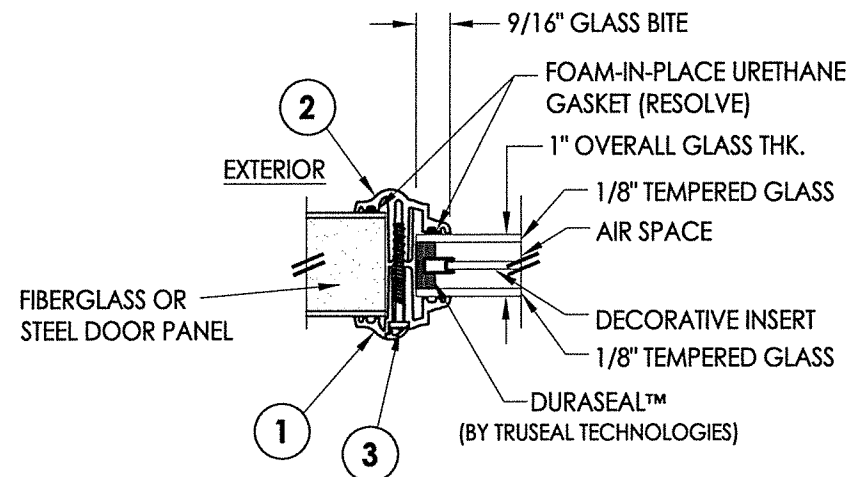

**G2 GLAZING DETAIL**  
EVOLVE FRAME (1" DECOSEAL INSULATED GLASS)  
RESOLVE GASKET

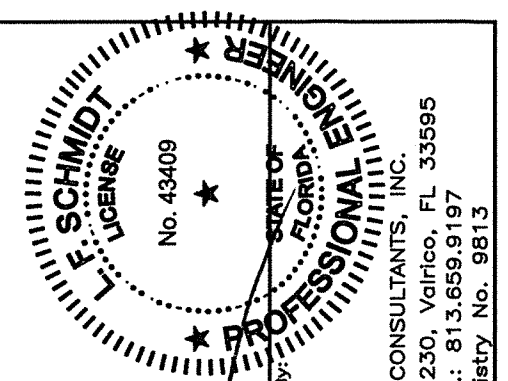

August 07, 2020  
Documents Prepared By:  
Lyndon F. Schmidt  
P.E. No. 43409  
R.W. BUILDING CONSULTANTS, INC.  
P.O. Box 230, Valrico, FL 33595  
Phone No.: 813.659.9197  
FBPE Registry No. 9813

|                   |   |
|-------------------|---|
| PRODUCT:          | EVOLVE LITE FRAME SYSTEM                    |
| PART OR ASSEMBLY: | FRAME & GLAZING DETAILS & BILL OF MATERIALS |
| DATE:             | 4/15/13                                     |
| SCALE:            | N.T.S.                                      |
| DWG. BY:          | JK  |
| CHK. BY:          | LFS   |
| DRAWING NO.:      | FL-15260.8                                  |
| SHEET             | 2 OF 4                                      |

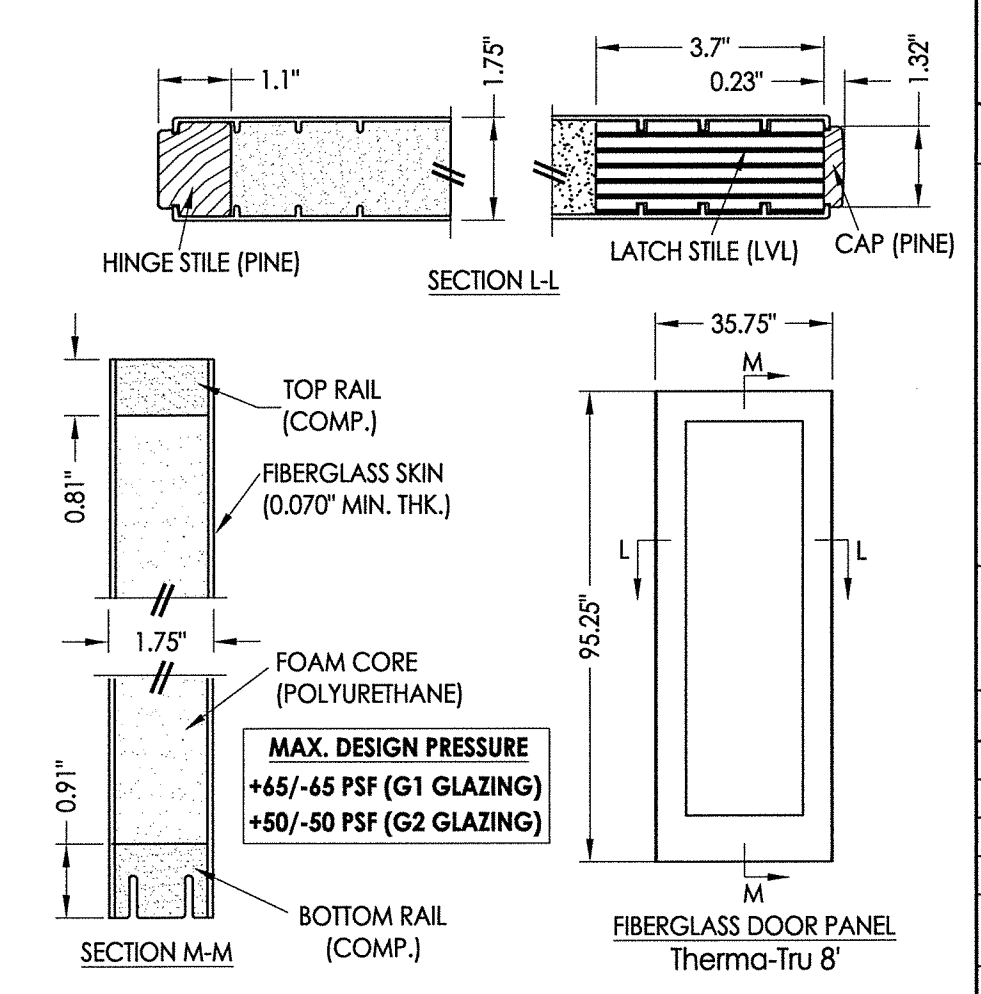
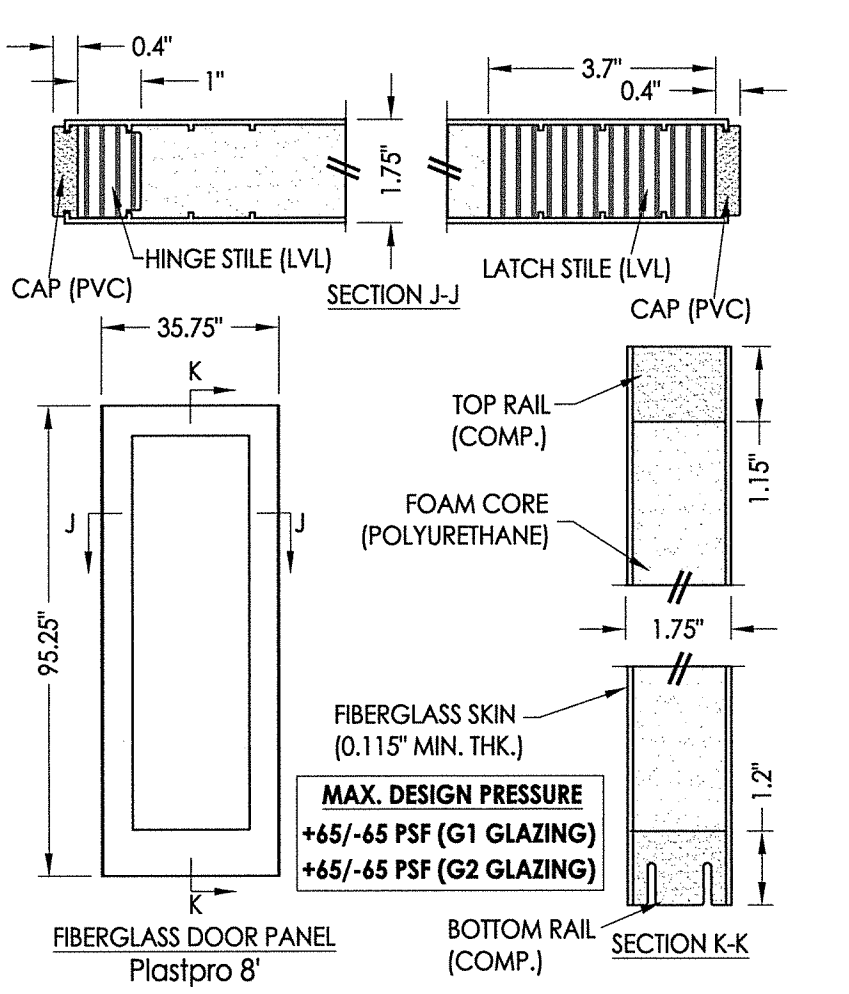
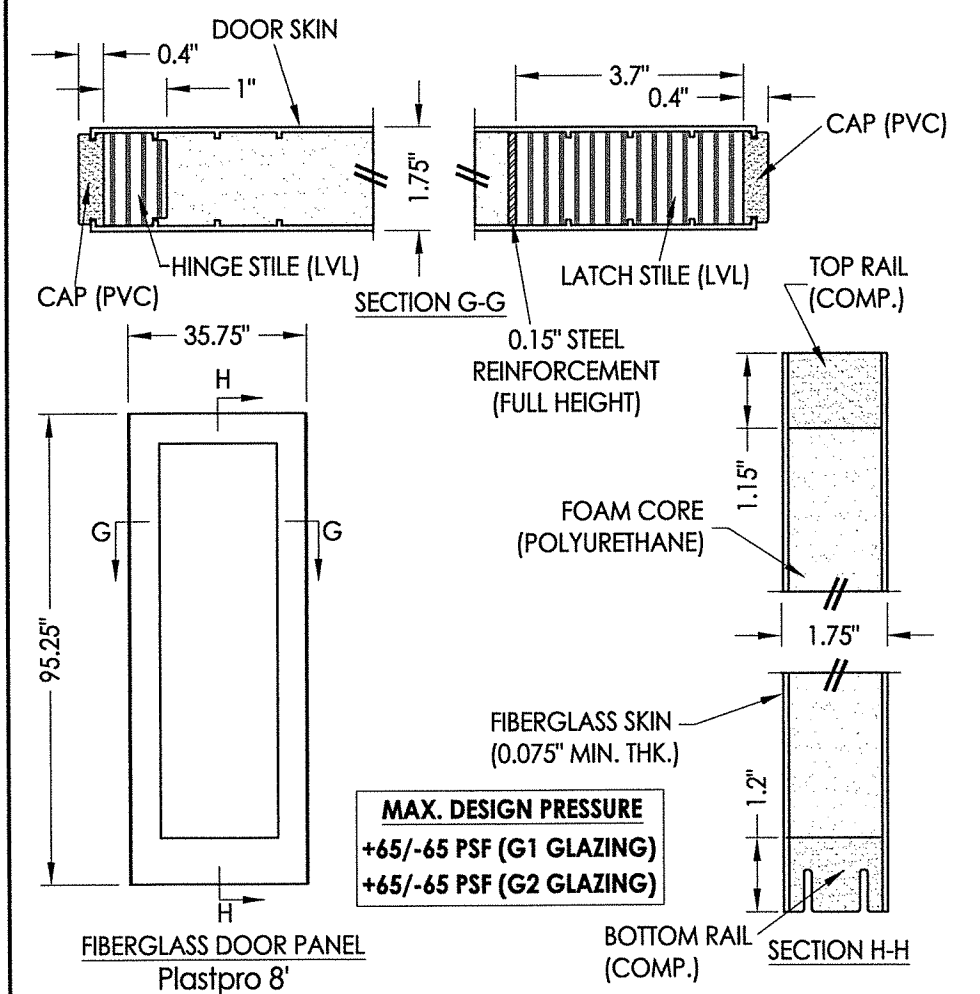
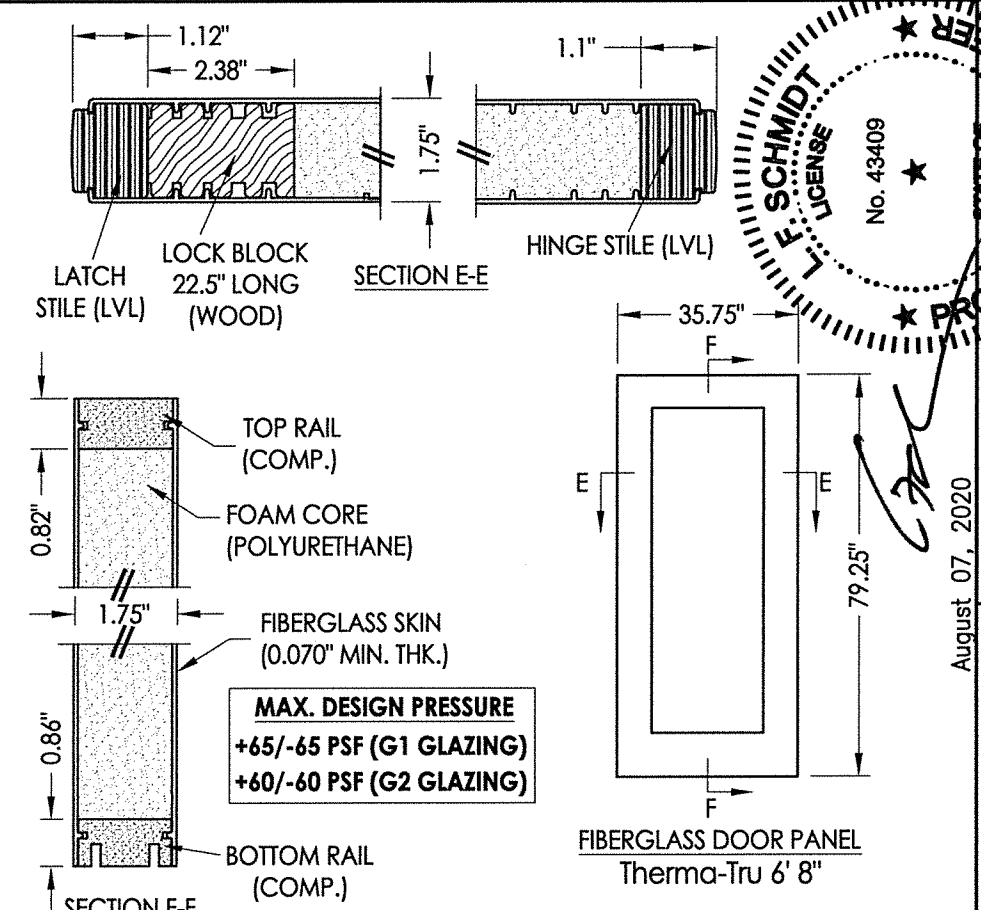
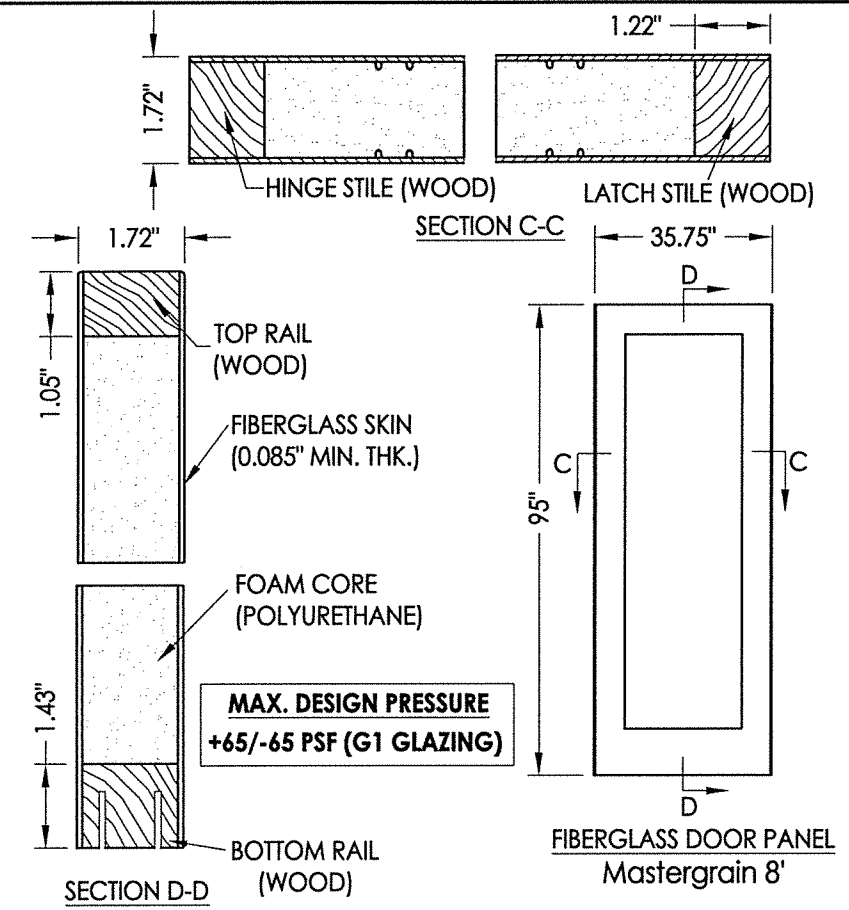
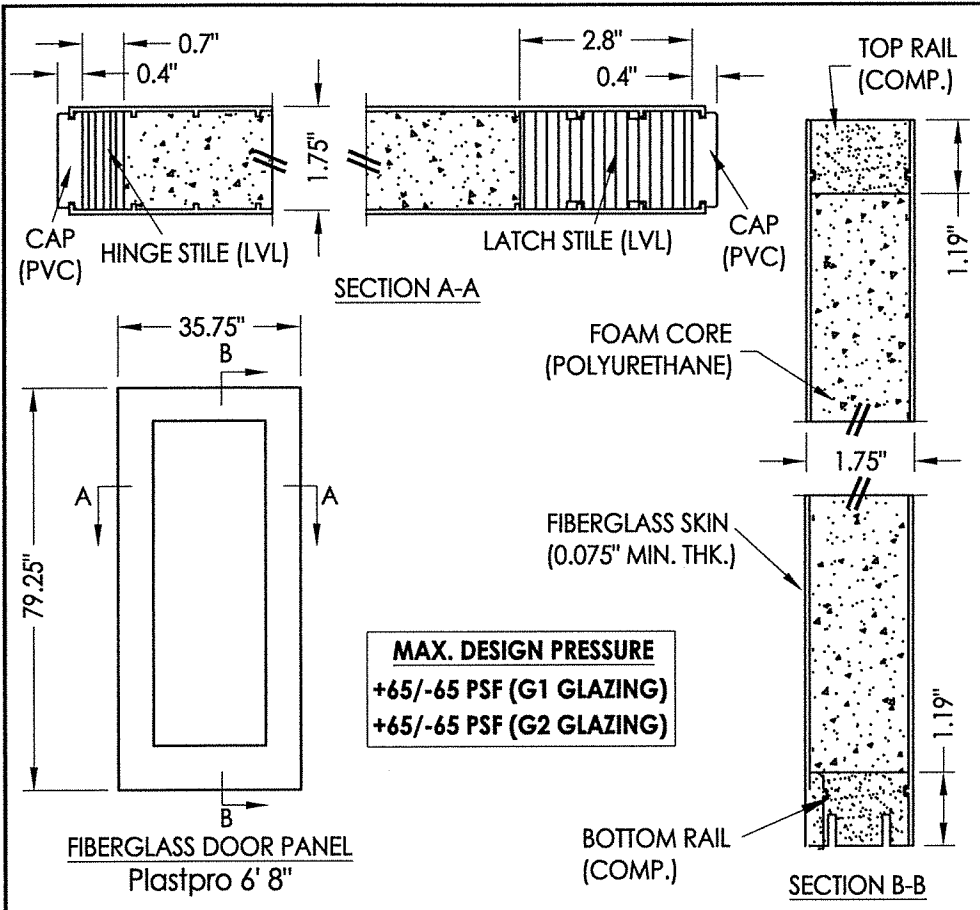

STATE OF FLORIDA  
REGISTERED PROFESSIONAL ENGINEER  
F. SCHMIDT  
LICENSE No. 43409

August 07, 2020  
Documents Prepared By:  
Lyndon F. Schmidt  
P.E. No. 43409

R.W. BUILDING CONSULTANTS, INC.  
P.O. Box 230, Valrico, FL 33595  
Phone No.: 813.659.9197  
FBPE Registry No. 9813

|                         |          |                                |     |
|-------------------------|----------|--------------------------------|-----|
| PRODUCT:                |          | EVOLVE LITE FRAME SYSTEM       |     |
| PART OR ASSEMBLY:       |          | FIBERGLASS DOOR PANELS         |     |
| NO.                     | DATE     | REVISIONS                      | BY  |
| 5                       | 8/05/20  | UPDATE TO 7TH ED. (2020) FBC   | DAC |
| 4                       | 4/04/19  | UPDATE D.P. FOR NEW TESTING    | LFS |
| 3                       | 10/03/18 | ADD DOOR PANELS & GLAZING DET. | JFK |
| 2                       | 9/26/17  | UPDATE TO 6TH ED. (2017) FBC   | JK  |
| 1                       | 3/28/15  | UPDATE TO 5TH ED. (2014) FBC   | JK  |
| DATE: 4/15/13           |          | SCALE: N.T.S.                  |     |
| DWG. BY: JK             |          | CHK. BY: LFS                   |     |
| DRAWING NO.: FL-15260.8 |          | SHEET 3 OF 4                   |     |

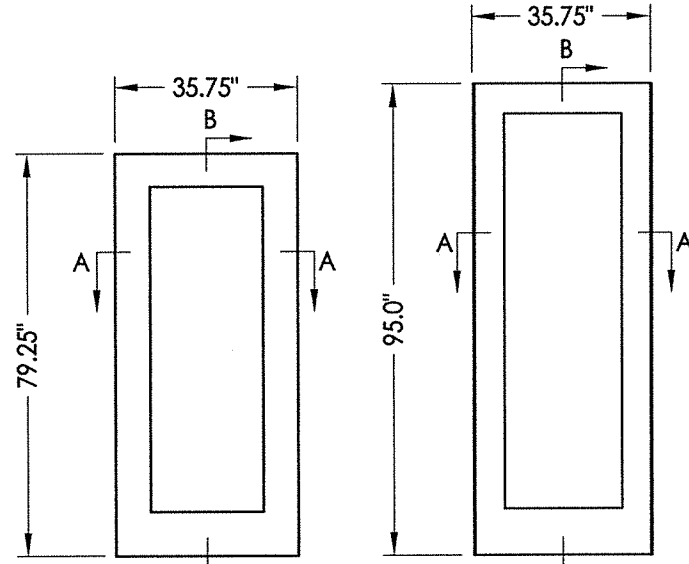
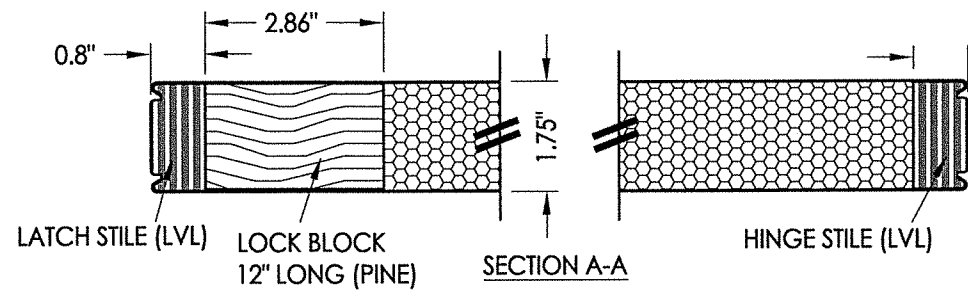

**MAX. DESIGN PRESSURE**  
 +60/-60 PSF (G1 GLAZING)  
 +60/-60 PSF (G2 GLAZING)

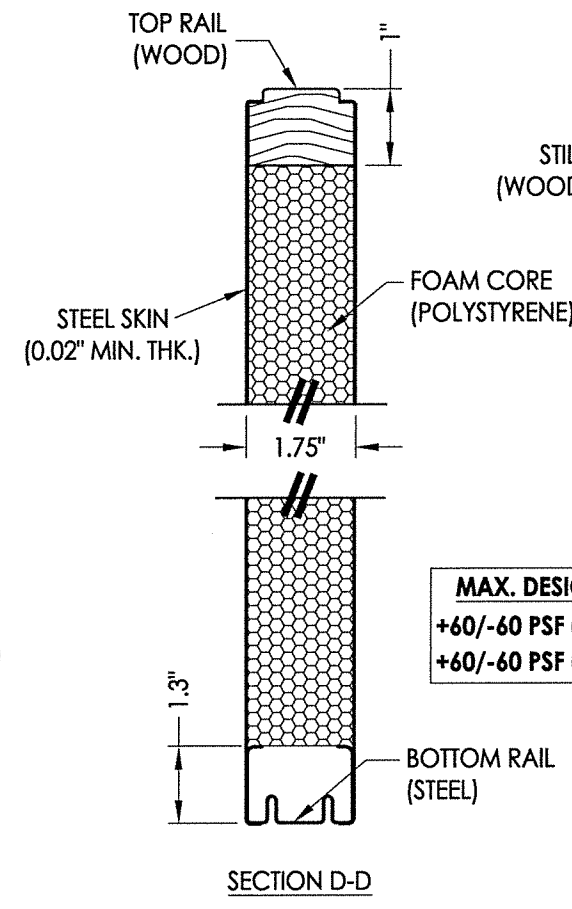
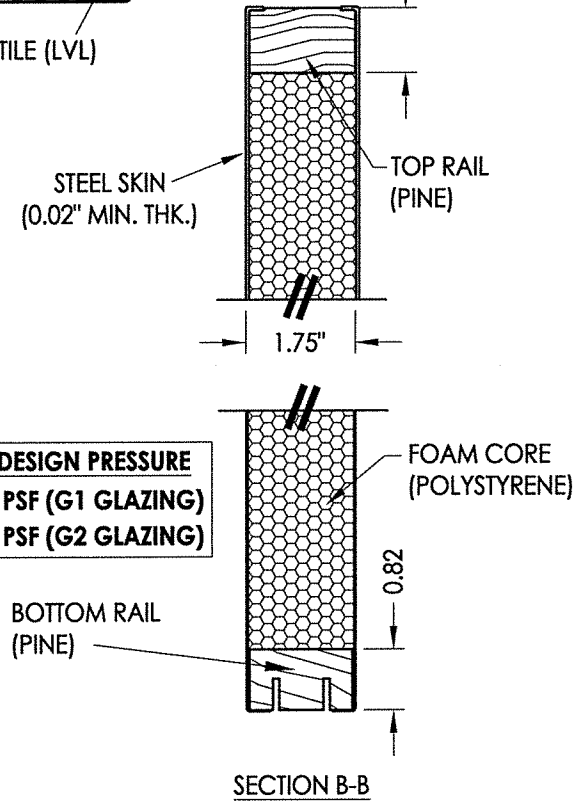

**MAX. DESIGN PRESSURE**  
 +60/-60 PSF (G1 GLAZING)  
 +60/-60 PSF (G2 GLAZING)

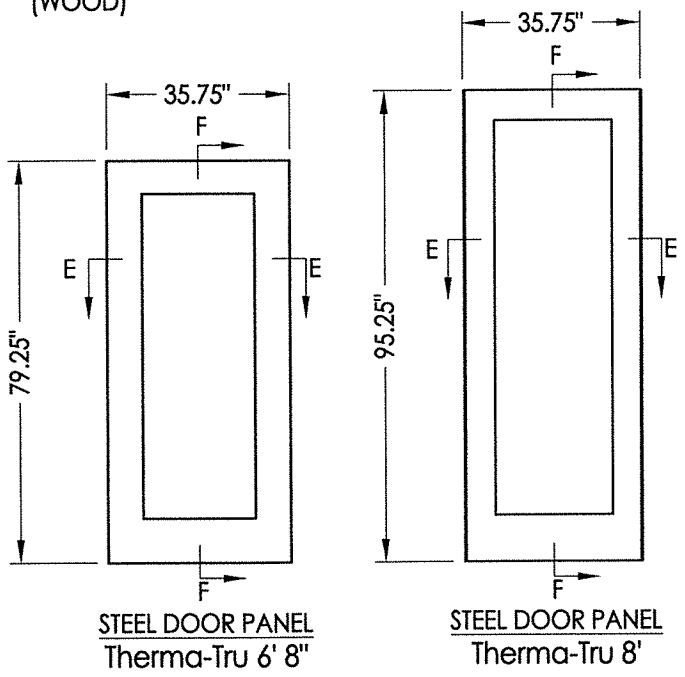
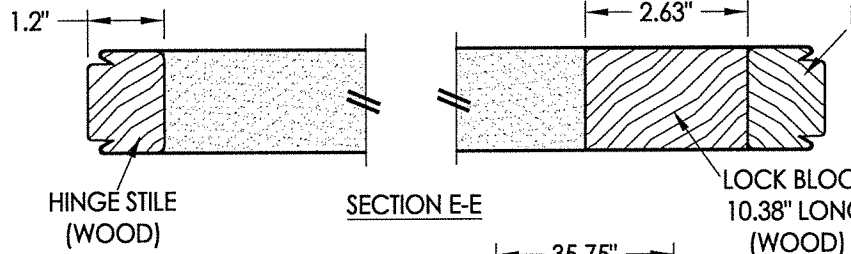
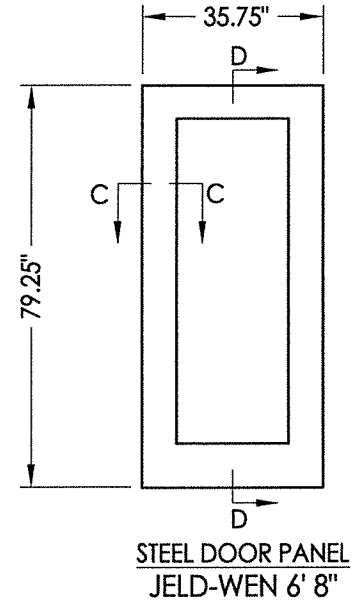
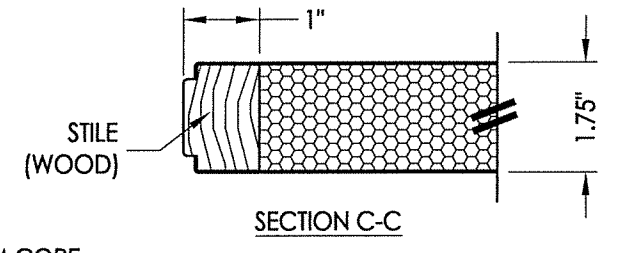

**MAX. DESIGN PRESSURE**  
 +60/-60 PSF (G1 GLAZING)  
 +60/-60 PSF (G2 GLAZING)

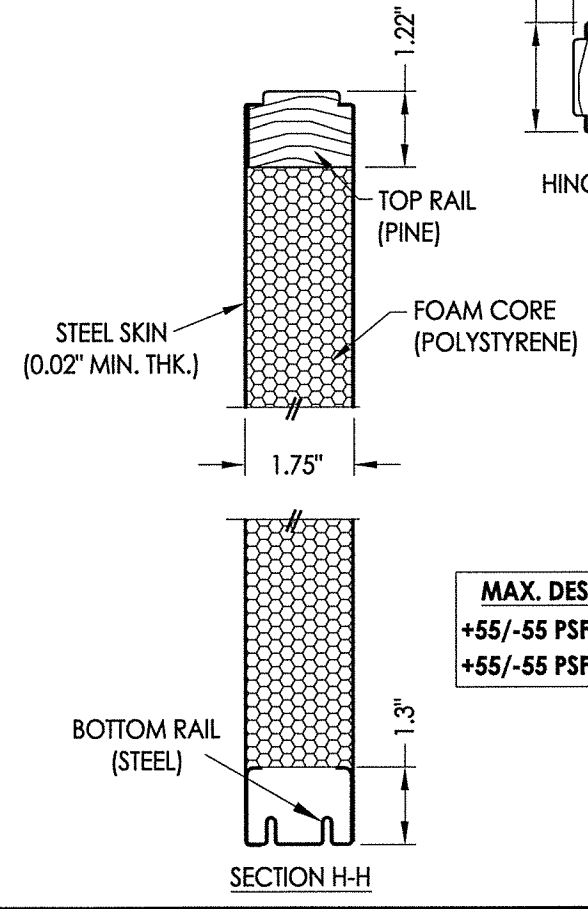
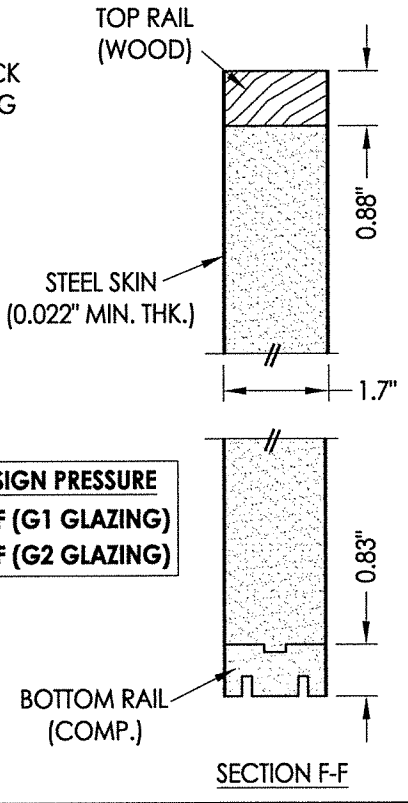

**MAX. DESIGN PRESSURE**  
 +55/-55 PSF (G1 GLAZING)  
 +55/-55 PSF (G2 GLAZING)

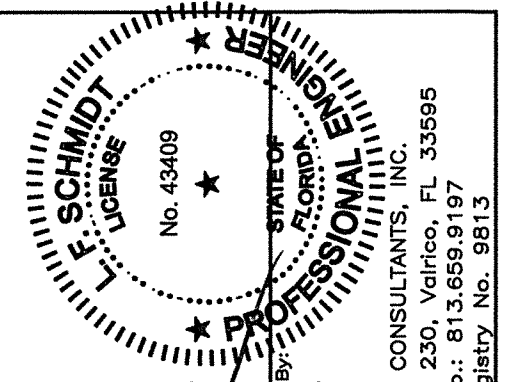
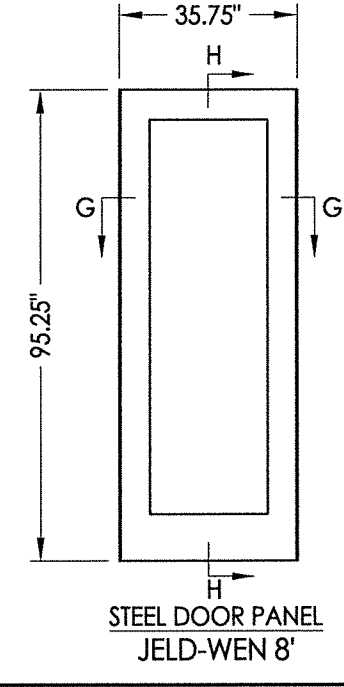
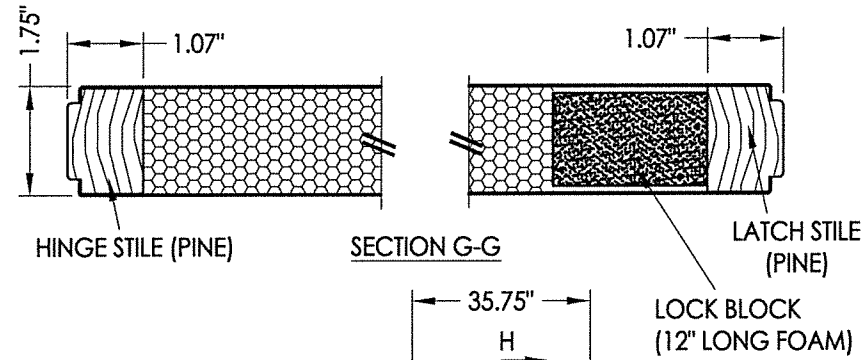

August 07, 2020  
 Documents Prepared By:  
 Lyndon F. Schmidt  
 P.E. No. 43409

PRODUCT:  
 EVOLVE  
 LITE FRAME SYSTEM

PART OR ASSEMBLY:  
 STEEL DOOR PANELS

| NO. | DATE     | REVISIONS                      |
|-----|----------|--------------------------------|
| 5   | 8/05/20  | UPDATE TO 7TH ED. (2020) FBC   |
| 4   | 4/04/19  | UPDATE D.P. FOR NEW TESTING    |
| 3   | 10/03/18 | ADD DOOR PANELS & GLAZING DET. |
| 2   | 9/26/17  | UPDATE TO 6TH ED. (2017) FBC   |
| 1   | 3/28/15  | UPDATE TO 5TH ED. (2014) FBC   |

DATE: 4/15/13  
 SCALE: N.T.S.  
 DWG. BY: JK  
 CHK. BY: LFS  
 DRAWING NO.: FL-15260.8  
 SHEET 4 OF 4