

2
2 HORIZONTAL CROSS SECTION

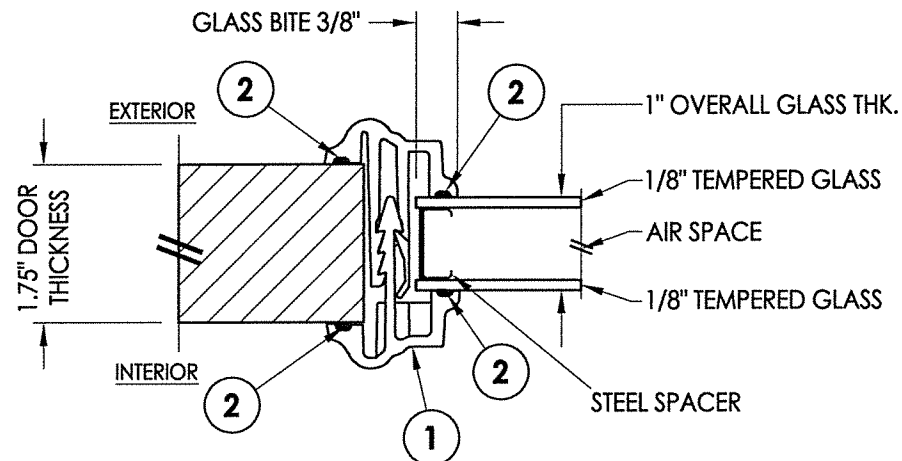

G1 GLAZING DETAIL

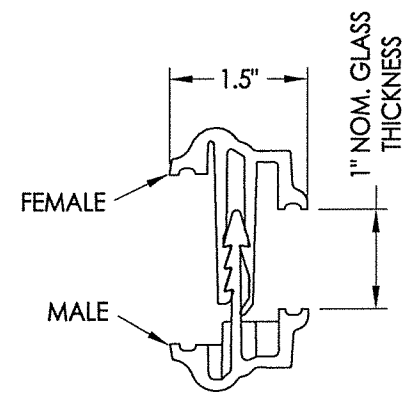

ODLSMART FRAME
HP POLYPROPYLENE

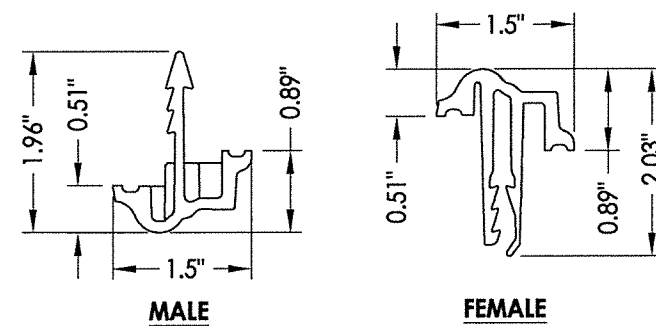

1 SMART FRAME

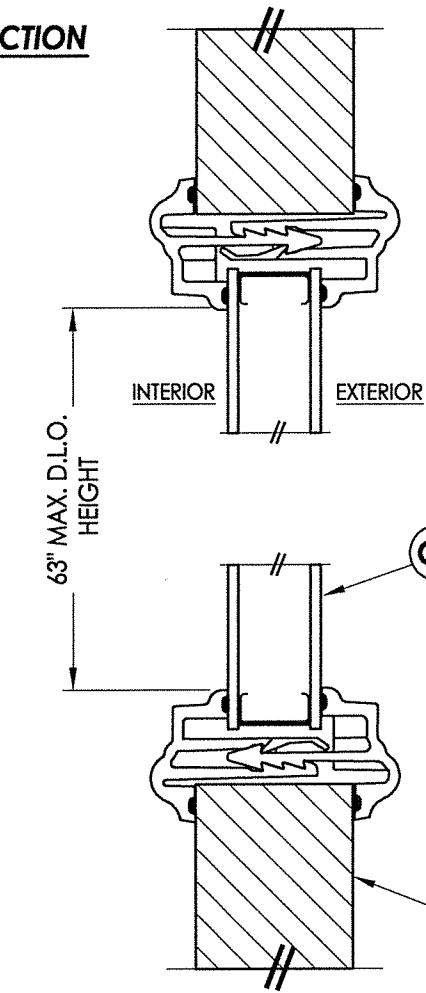
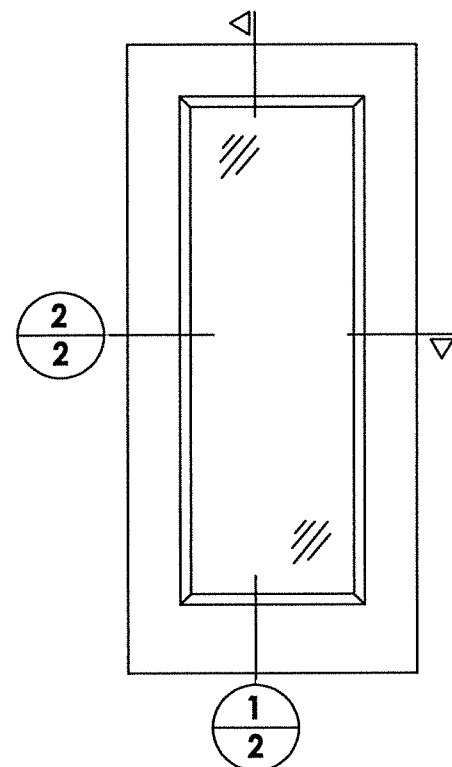

1
2 VERTICAL CROSS SECTION

DOOR PANEL UNDER SEPARATE APPROVAL (TYP.)

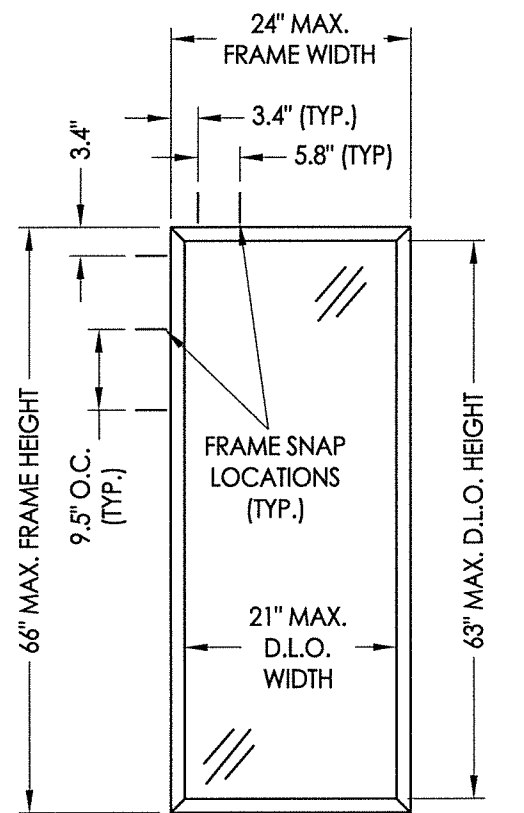

24" x 66" SMART FRAME DOORGLASS

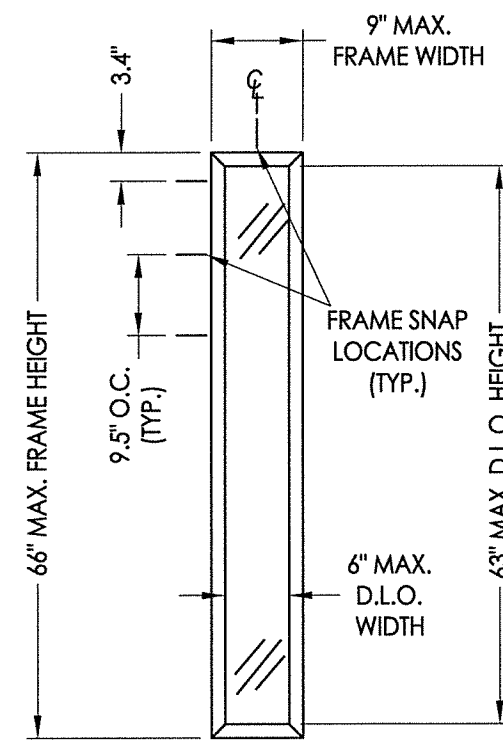

9" x 66" SMART FRAME DOORGLASS

BILL OF MATERIALS		
ITEM #	DESCRIPTION	MATERIAL
1	ODL SMART FRAME	HP POLYPRO
2	FOAM-IN-PLACE GASKET	URETHANE

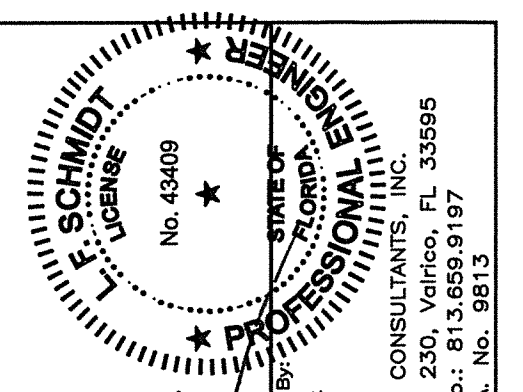

August 07, 2020
 Documents Prepared By:
 Lyndon F. Schmidt
 P.E. No. 43409

RW BUILDING CONSULTANTS, INC.
 P.O. Box 230, Valrico, FL 33595
 Phone No.: 813.659.9197
 FBPE C.A. No. 9813

PRODUCT: SMART FRAME	
PART OR ASSEMBLY: CROSS SECTIONS & GLAZING DETAILS	
NO.	DATE
4	8/05/20
3	9/27/18
2	9/26/17
1	3/28/15
REVISIONS	
DATE:	2/29/12
SCALE:	N.T.S.
DWG. BY:	JK
CHK. BY:	LFS
DRAWING NO.:	FL-15260.4
SHEET	2 OF 3

\\dc01\wbc\Clients\ODL, Inc. PERMANENTA - Florida Product Approvals\FL-15260 Exterior Door Components - Lite Frame Inserts\C - Drawings\FL 15260 (2020) R9\FL-15260.4.dwg

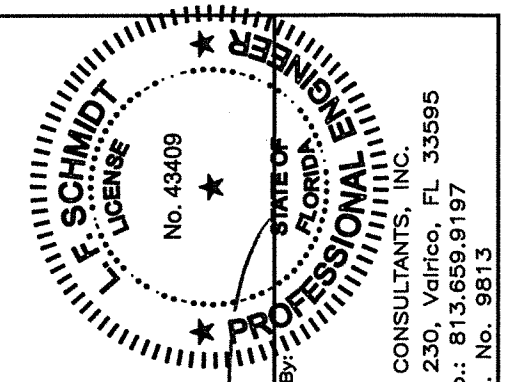
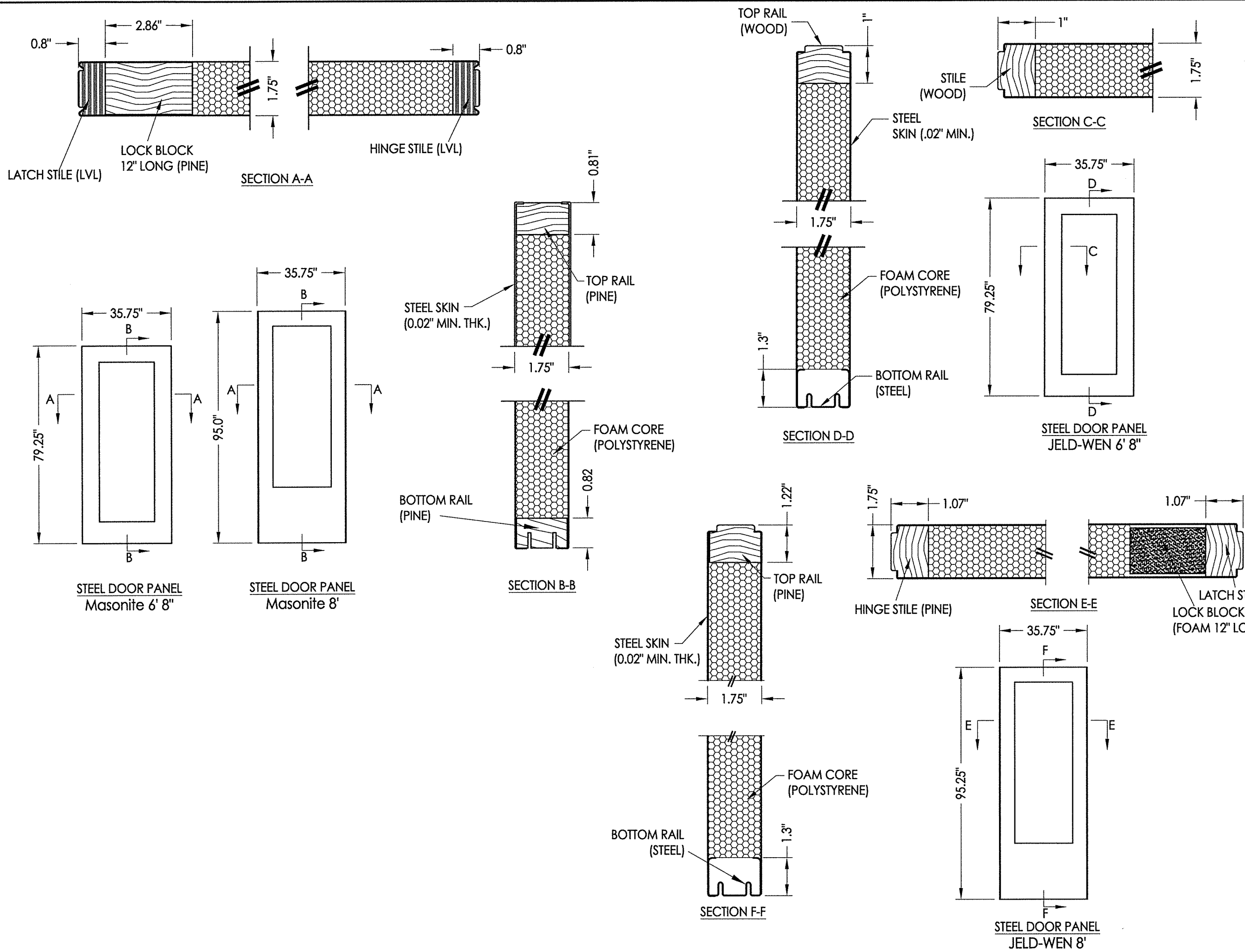

Documents Prepared By:
 Lyndon F. Schmidt
 P.E. No. 43409
 August 07, 2020
 R.W. BUILDING CONSULTANTS, INC.
 P.O. Box 230, Valrico, FL 33595
 Phone No.: 813.659.9197
 FBPE C.A. No. 9813

PRODUCT:		SMART FRAME	
PART OR ASSEMBLY:		STEEL DOOR PANELS	
NO.	DATE	BY	REVISIONS
4	8/05/20	JAC	UPDATE TO 7TH ED. (2020) FBC
3	9/27/18	LFS	REMOVED TRADITIONAL FRAME
2	9/26/17	JK	UPDATE TO 6TH ED. (2017) FBC
1	3/28/15	JK	UPDATE TO 5TH ED. (2014) FBC
DATE: 2/29/12			
SCALE: N.T.S.			
DWG. BY: JK			
CHK. BY: LFS			
DRAWING NO.: FL-15260.4			
SHEET 3 OF 3			