

**"ZEEL" CLIP ASSEMBLED LITE FRAME SYSTEM**  
PC/ABS

LOCKING CLIP IN (32) PLACES  
(SPACED @ 6.75"-7.25" O.C.)

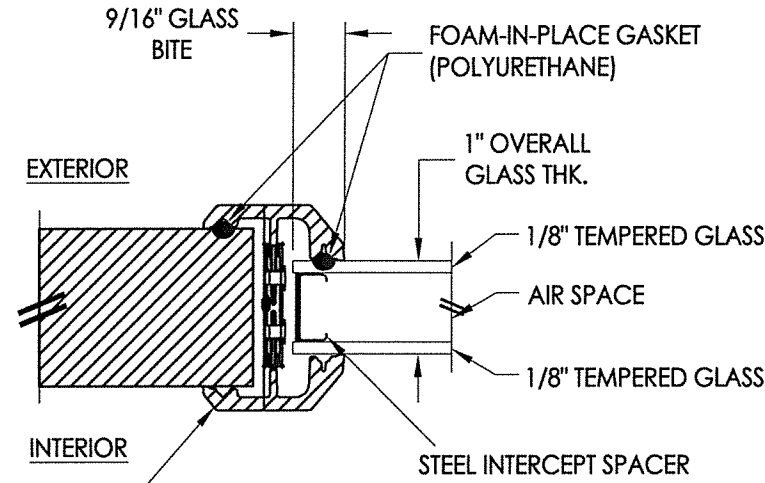

**G1 GLAZING DETAIL**

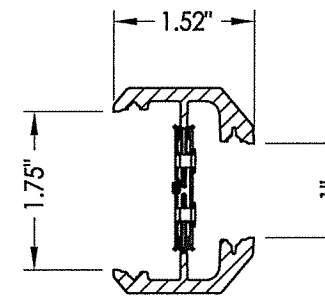

**2A ZEEL LITE FRAME**  
CLIP ASSEMBLED FRAME  
PC/ABS

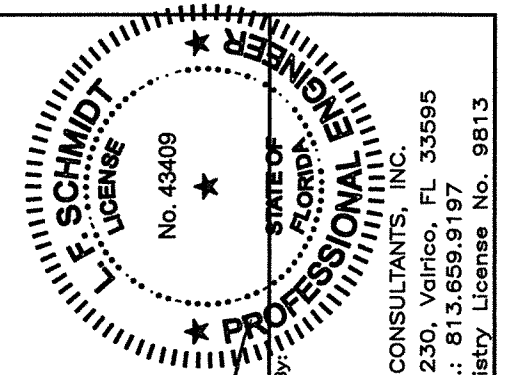

*LF*

August 07, 2020

Documents Prepared By:  
Lyndon F. Schmidt  
P.E. No. 43409

**RW** BUILDING CONSULTANTS, INC.  
P.O. Box 230, Valrico, FL 33595  
Phone No.: 813.659.9197  
FBPE Registry License No. 9813

PRODUCT:		ZEEL LITE FRAME SYSTEM	
PART OR ASSEMBLY:		LITE FRAME & GLAZING DETAILS	
NO.	DATE	BY	REVISIONS
1	8/05/20	FBC	UPDATE TO 7th ED. (2020)
		DAC	
DATE: 10/02/19			
SCALE: N.T.S.			
DWG. BY: LFS			
CHK. BY: RW			
DRAWING NO.: FL-15260.19			
SHEET 2 of 4			

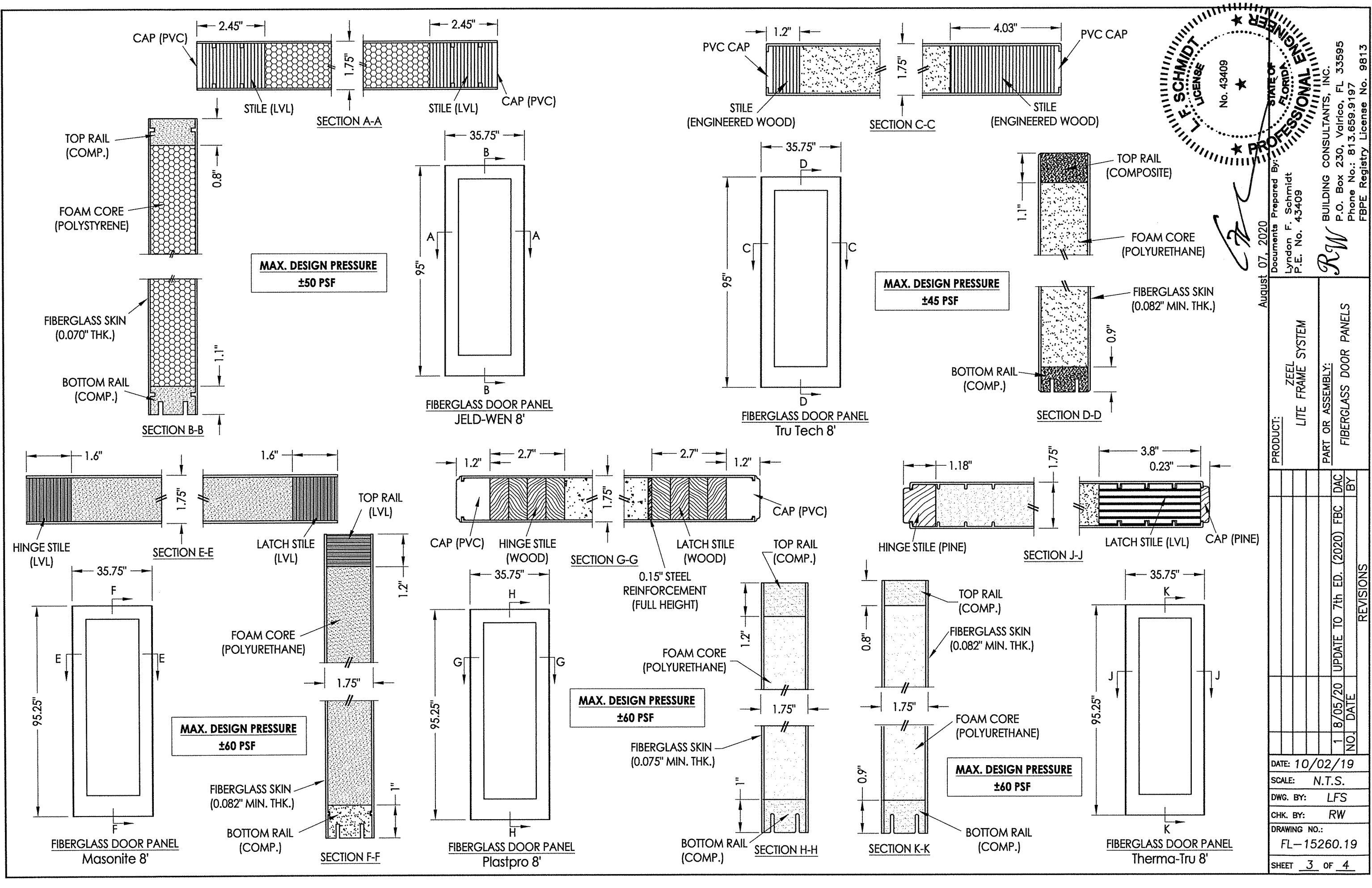

**FLORIDA PROFESSIONAL ENGINEER**  
No. 43409  
STATE OF FLORIDA

August 07, 2020  
Documents Prepared By:  
Lyndon F. Schmidt  
P.E. No. 43409

**R.W.**  
BUILDING CONSULTANTS, INC.  
P.O. Box 230, Valrico, FL 33595  
Phone No.: 813.659.9197  
FBPE Registry License No. 9813

PRODUCT:		ZEEEL LITE FRAME SYSTEM	
PART OR ASSEMBLY:		FIBERGLASS DOOR PANELS	
NO.	DATE	BY	DATE
1	8/05/20	FBC	8/05/20
REVISIONS			
DATE: 10/02/19			
SCALE: N.T.S.			
DWG. BY: LFS			
CHK. BY: RW			
DRAWING NO.: FL-15260.19			
SHEET 3 OF 4			

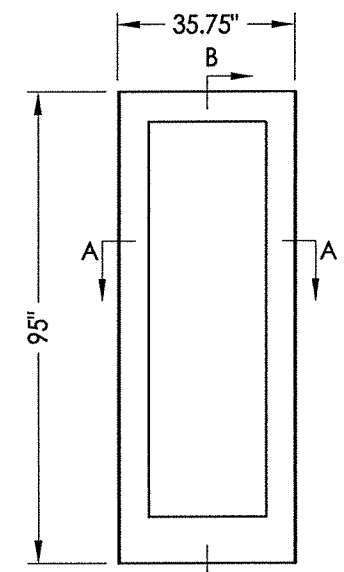
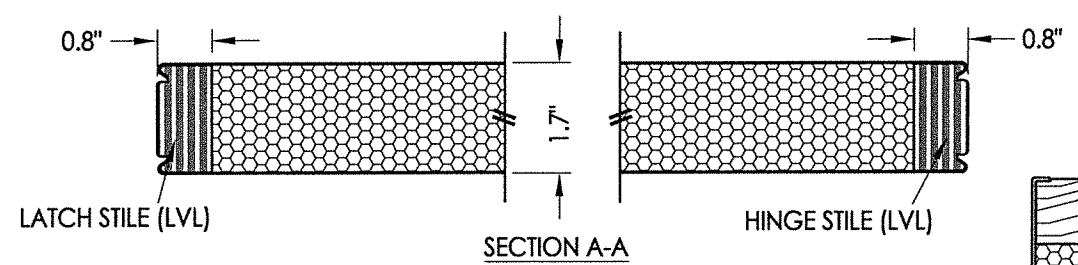

**MAX. DESIGN PRESSURE**  
**±50 PSF**

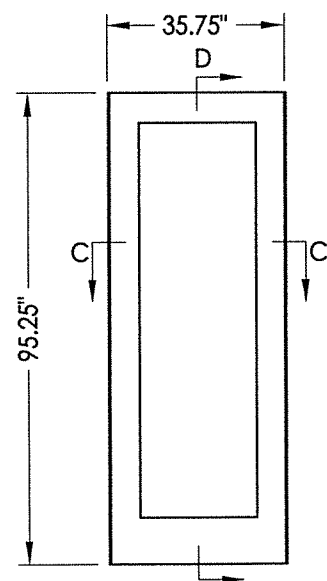
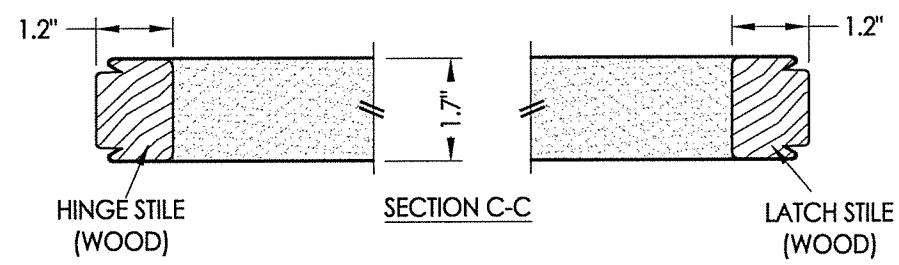
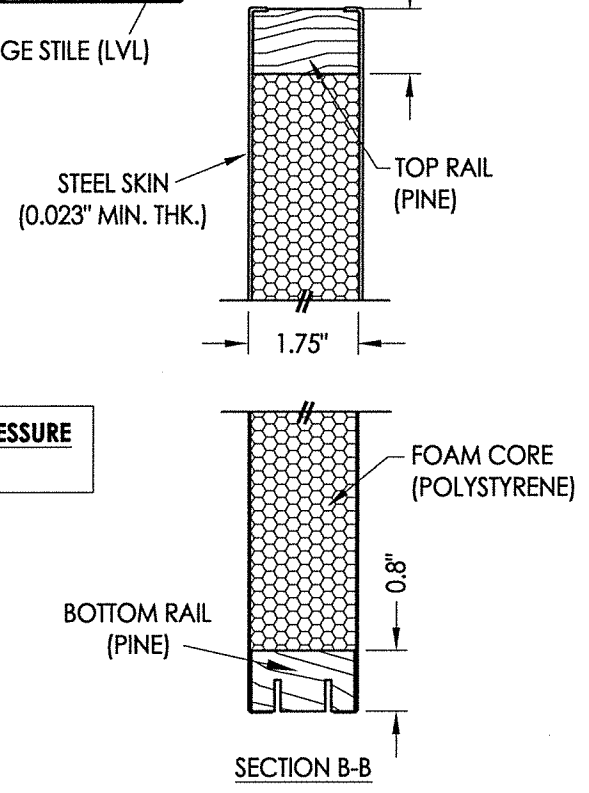

**MAX. DESIGN PRESSURE**  
**±50 PSF**

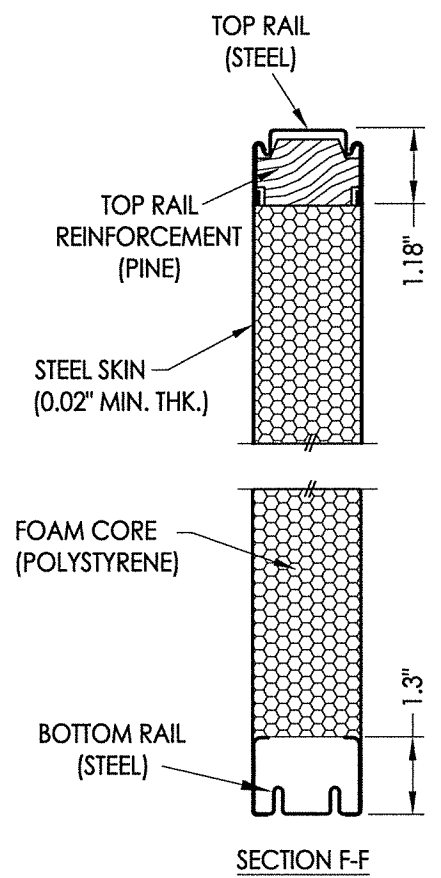
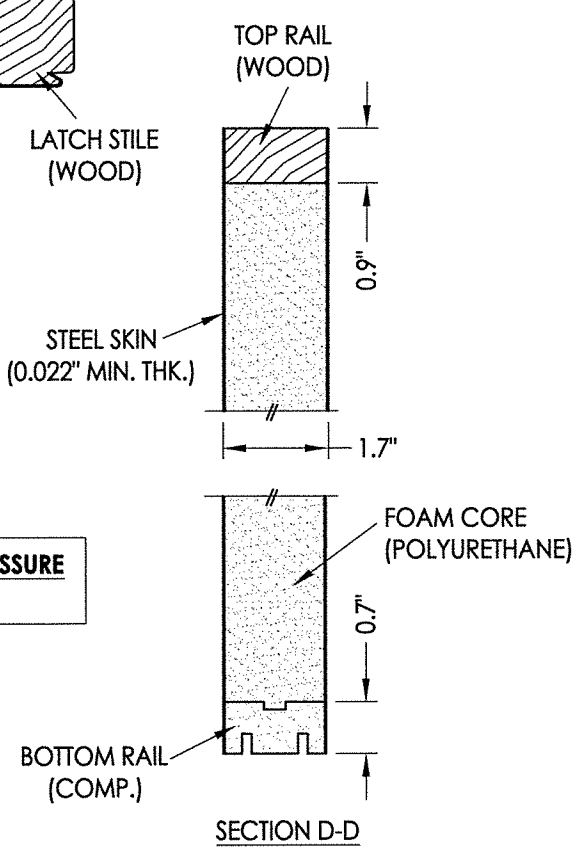

**MAX. DESIGN PRESSURE**  
**±50 PSF**

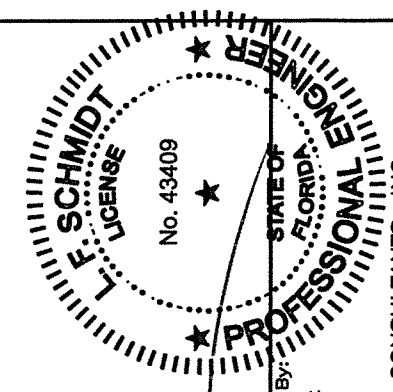
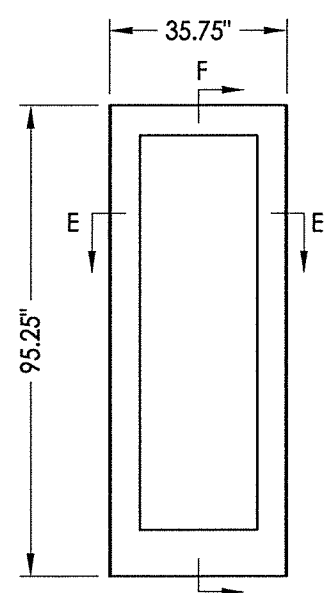
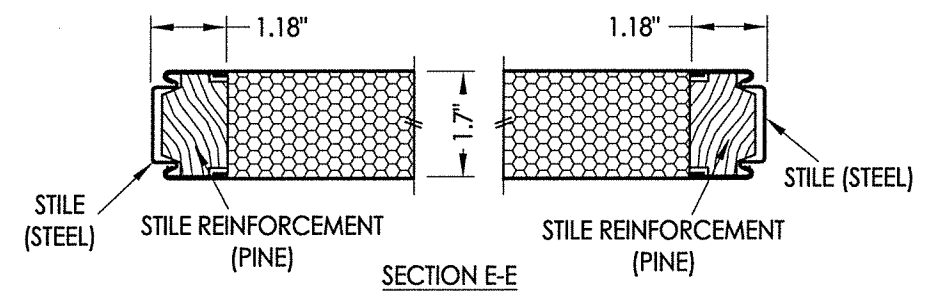

*LFS*

August 07, 2020  
Documents Prepared By:  
Lyndon F. Schmidt  
P.E. No. 43409  
R.W. BUILDING CONSULTANTS, INC.  
P.O. Box 230, Vairico, FL 33595  
Phone No.: 813.659.9197  
FBPE Registry License No. 9813

PRODUCT:		ZEEL LITE FRAME SYSTEM	
PART OR ASSEMBLY:		STEEL DOOR PANELS	
NO.	DATE	BY	REVISIONS
1	8/05/20	FBC	UPDATE TO 7th ED. (2020)
		DAC	
DATE: 10/02/19		SCALE: N.T.S.	
DWG. BY: LFS		CHK. BY: RW	
DRAWING NO.: FL-15260.19		SHEET 4 OF 4	