

\\dc01\rbwbc\Clients\ODL, Inc. PERMANENT\A - Florida Product Approvals\FL-15260 Exterior Door Components - Lite Frame Inserts\C - Drawings\FL-15260 (2020) R9\FL-15260.1-2.dwg

BILL OF MATERIALS		
ITEM #	DESCRIPTION	MATERIAL
1	TriSys FRAME SYSTEM	-
2	INT. FRAME (HP POLYPROPYLENE)	-
3	EXT. FRAME ("FIBERMATE" PC ABS)	-
4	#7-19 X 1-3/4" PPH SELF DRILLING SMS	STEEL
5	FRAME COVER (ABS)	-
7	FRAME CLIP	STEEL
8	FIPG (Foam-In-Place-Gasket)	POLYURETHANE

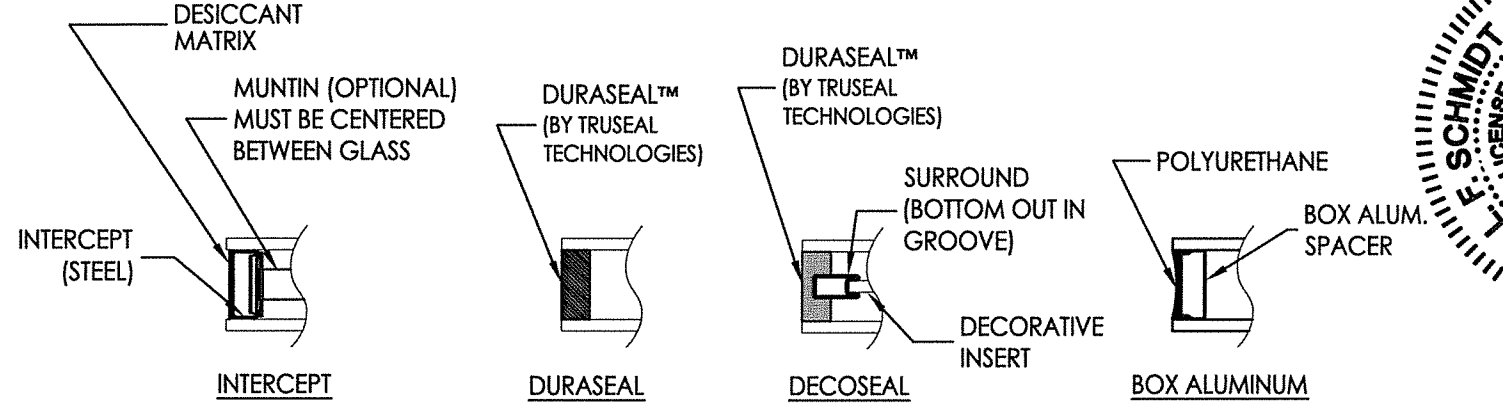

OPTIONAL GLAZING SPACER DETAILS

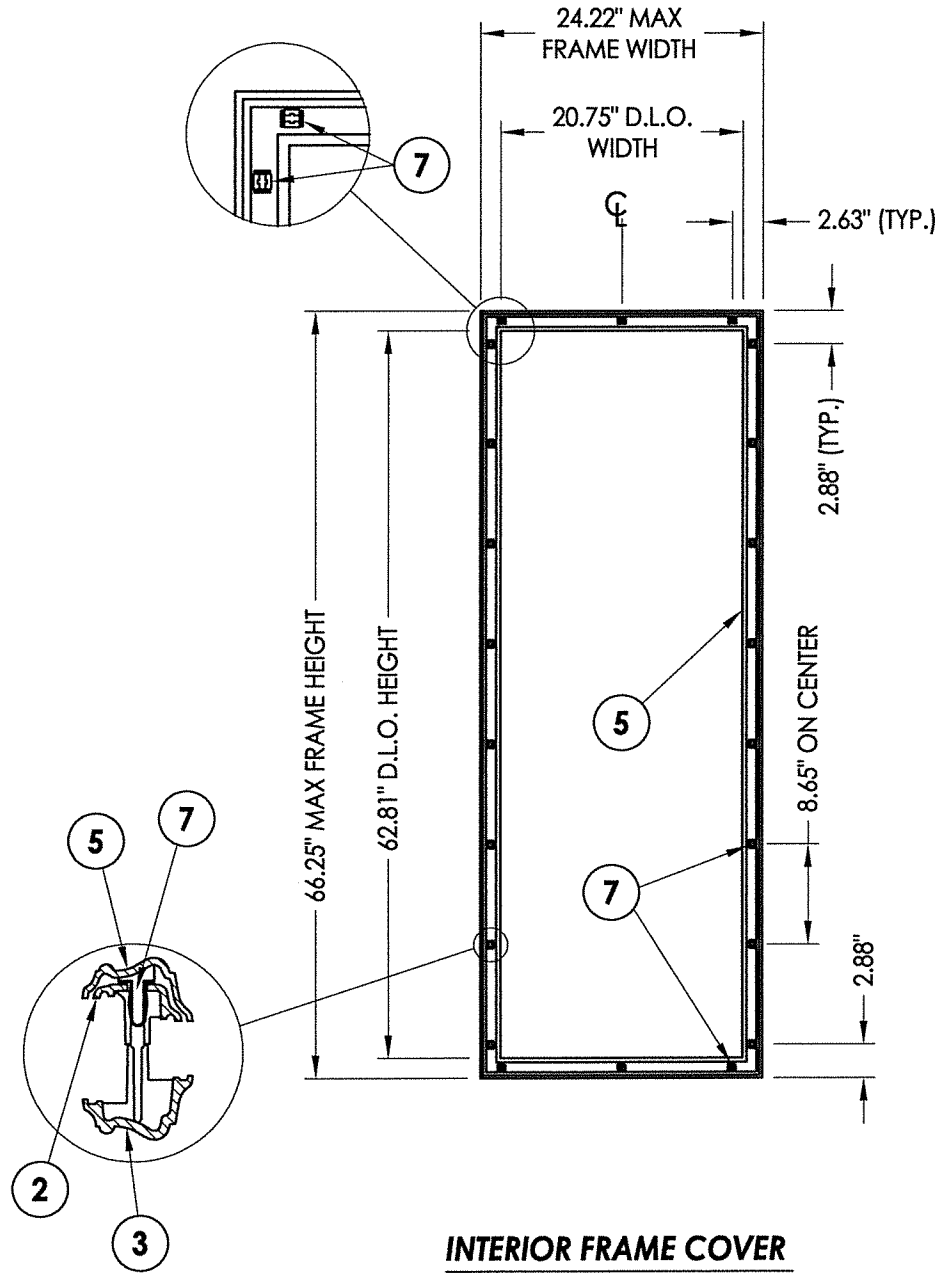
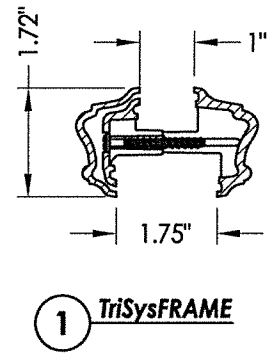

INTERIOR FRAME COVER

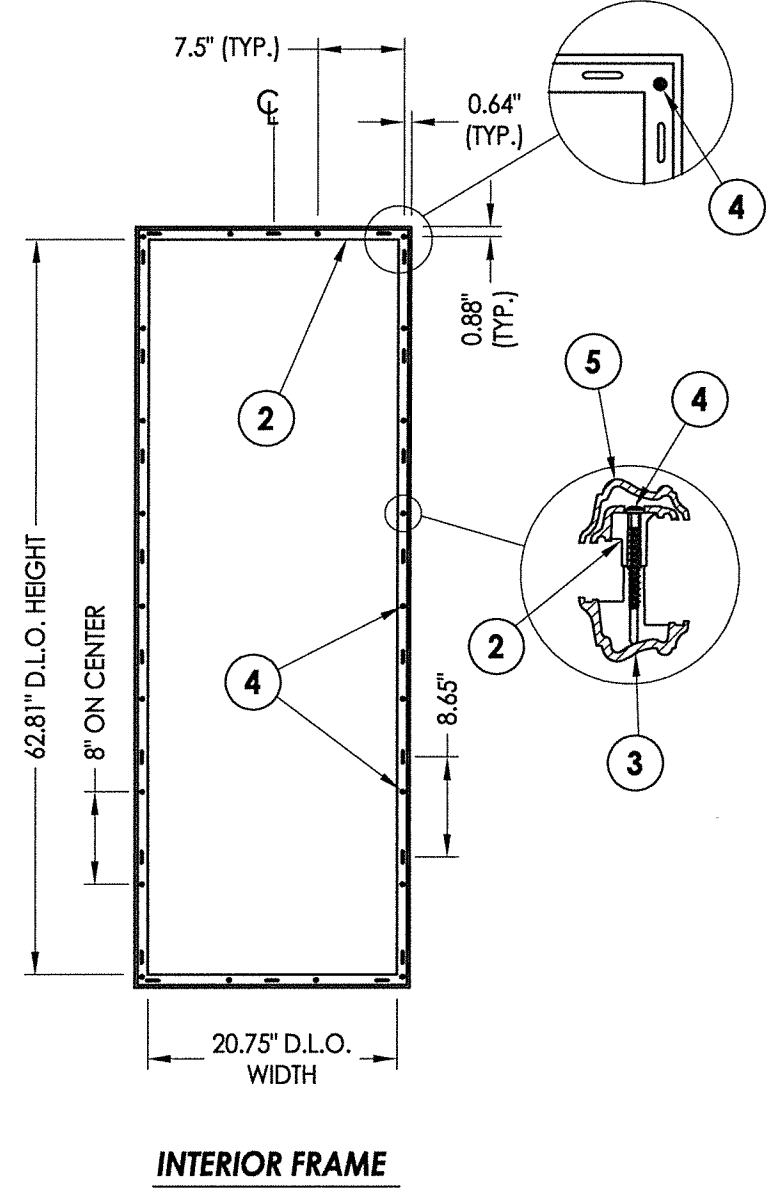

INTERIOR FRAME

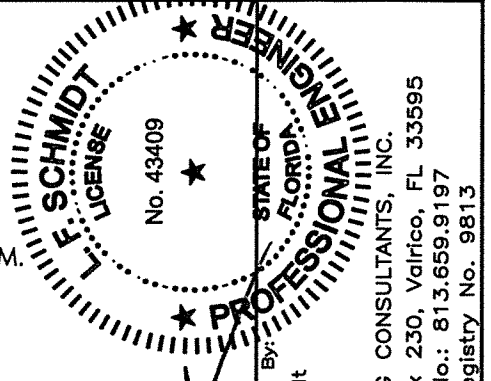
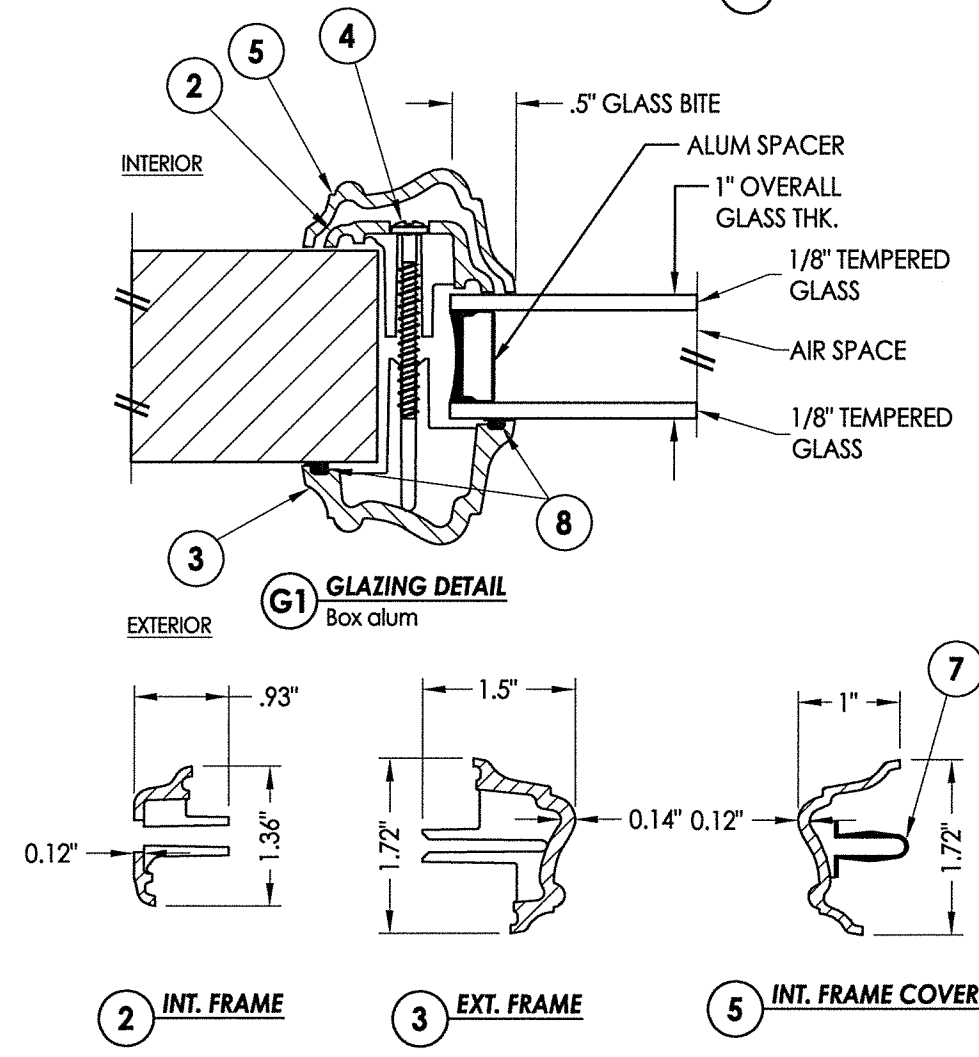

August 07, 2020

Documents Prepared By:
Lyndon F. Schmidt
P.E. No. 43409
R.W. BUILDING CONSULTANTS, INC.
P.O. Box 230, Valrico, FL 33595
Phone No.: 813.659.9197
FBPE Registry No. 9813

PRODUCT:		TriSys FRAME SYSTEM	
PART OR ASSEMBLY:		CROSS SECTIONS, GLAZING DETAILS & BILL OF MATERIALS	
NO.	DATE	BY	REVISIONS
3	8/50/20	DAC	UPDATE TO 7TH ED. (2020) FBC
2	9/26/17	JK	UPDATE TO 6TH ED. (2017) FBC
1	3/28/15	JK	UPDATE TO 5TH ED. (2014) FBC
DATE: 2/29/12			
SCALE: N.T.S.			
DWG. BY: JK			
CHK. BY: LFS			
DRAWING NO.: FL-15260.1			
SHEET 2 OF 4			

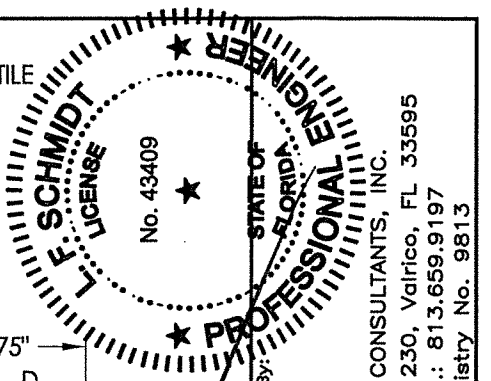
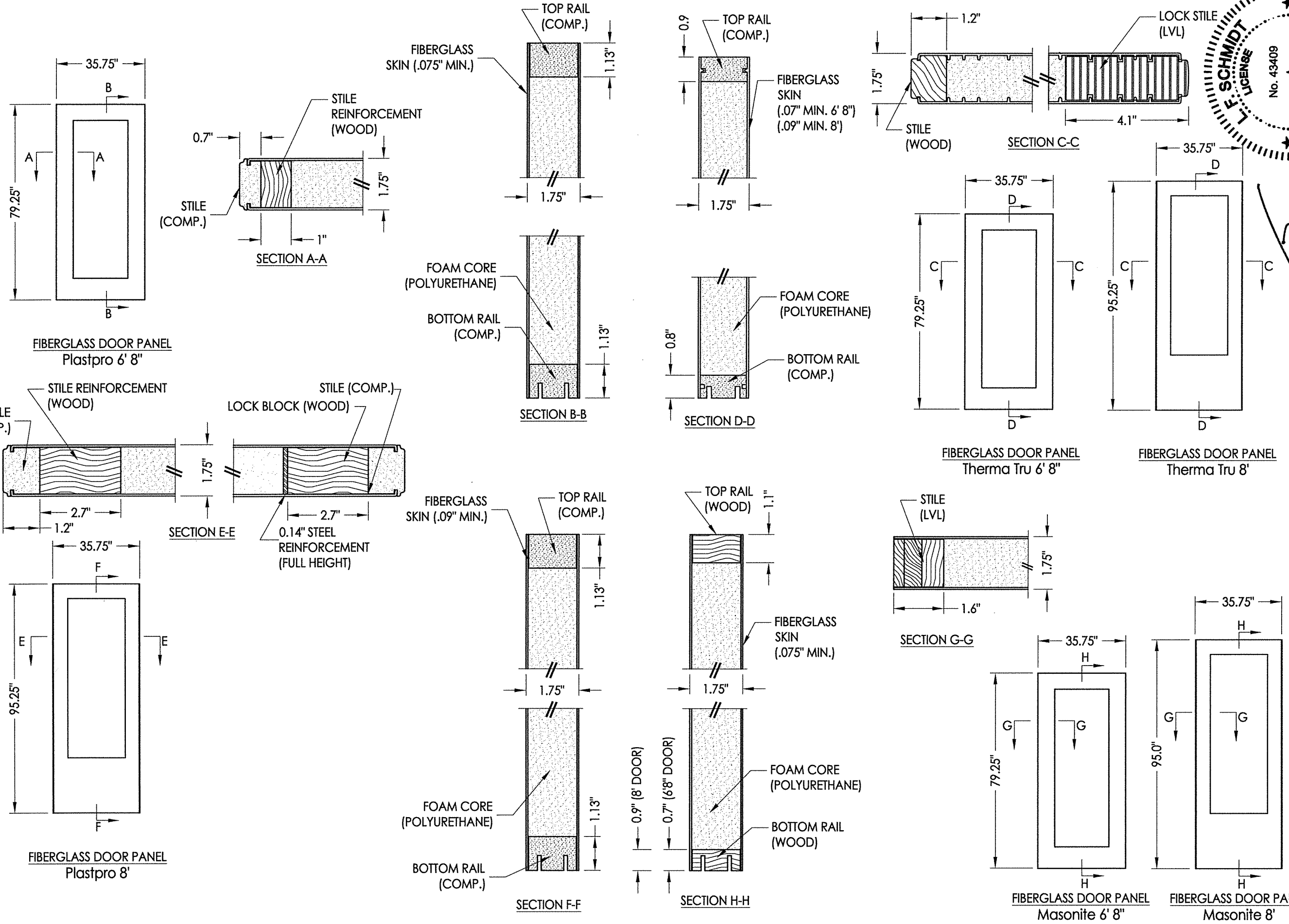

August 07, 2020
 Documents Prepared By:
 Lyndon F. Schmidt
 P.E. No. 43409

RW
 BUILDING CONSULTANTS, INC.
 P.O. Box 230, Valrico, FL 33595
 Phone No.: 813.659.9197
 FBPE Registry No. 9813

PRODUCT:		TriSys FRAME SYSTEM	
PART OR ASSEMBLY:		FIBERGLASS DOOR PANELS	
NO.	DATE	BY	REVISIONS
3	8/50/20	DAC	UPDATE TO 7TH ED. (2020) FBC
2	9/26/17	JK	UPDATE TO 6TH ED. (2017) FBC
1	3/28/15	JK	UPDATE TO 5TH ED. (2014) FBC
DATE: 2/29/12			
SCALE: N.T.S.			
DWG. BY: JK			
CHK. BY: LFS			
DRAWING NO.: FL-15260.1			
SHEET 3 OF 4			

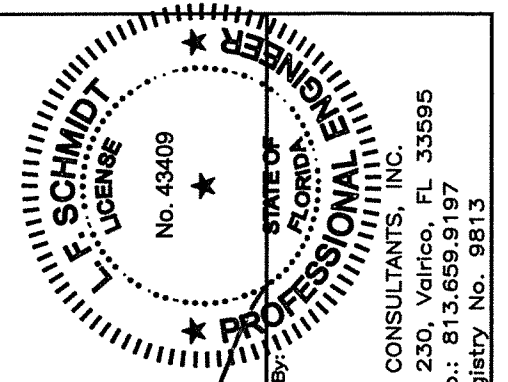
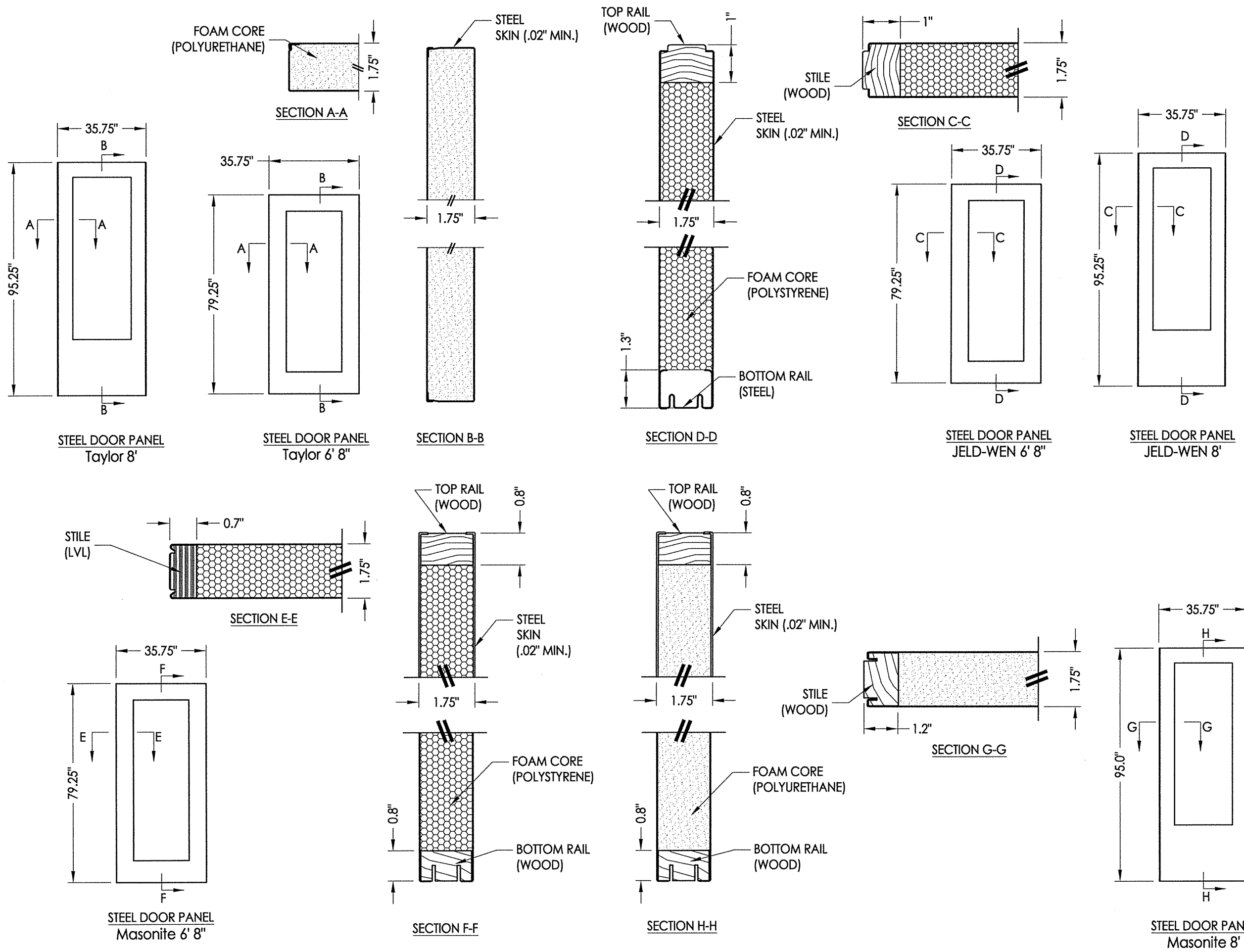

August 07, 2020
 Documents Prepared By:
 Lyndon F. Schmidt
 P.E. No. 43409

R.W. BUILDING CONSULTANTS, INC.
 P.O. Box 230, Valrico, FL 33595
 Phone No.: 813.659.9197
 FBPE Registry No. 9813

PRODUCT:		TriSys FRAME SYSTEM	
PART OR ASSEMBLY:		STEEL DOOR PANELS	
NO.	DATE	BY	REVISIONS
3	8/50/20	DAC	UPDATE TO 7TH ED. (2020) FBC
2	9/26/17	JK	UPDATE TO 6TH ED. (2017) FBC
1	3/28/15	JK	UPDATE TO 5TH ED. (2014) FBC
DATE: 2/29/12			
SCALE: N.T.S.			
DWG. BY: JK			
CHK. BY: LFS			
DRAWING NO.: FL-15260.1			
SHEET 4 OF 4			