



## EVALUATION SUBJECT: SIMPSON STRONG-TIE CONNECTORS FOR COLD-FORMED STEEL CONSTRUCTION

### REPORT HOLDER:

**Simpson Strong-Tie Company Inc.**  
5956 West Las Positas Boulevard  
Pleasanton, California 94588  
(800) 999-5099  
[www.strongtie.com](http://www.strongtie.com)

CSI Division: 05—METALS  
CSI Section: 05 05 23—Metal Fastenings

### 1.0 SCOPE OF EVALUATION

#### 1.1 Compliance to the following codes & regulations:

- 2015 International Building Code® (IBC)
- 2015 International Residential Code® (IRC)
- 2012 International Building Code® (IBC)
- 2012 International Residential Code® (IRC)
- 2009 International Building Code® (IBC)
- 2009 International Residential Code® (IRC)
- 2006 International Building Code® (IBC)
- 2006 International Residential Code® (IRC)

#### 1.2 Evaluated in accordance with:

- ICC-ES AC208.1, Acceptance Criteria for Connectors Used With Cold-Formed Steel Structural Members, approved October 2011, editorially revised May 2015.

#### 1.3 Properties assessed:

- Structural

#### 1.4 Reference Standards

The term *AISI Specification* used throughout this report refers to the reference standard for the applicable building code as follows:

- 2006 IBC – *North American Specification for the Design of Cold-Formed Steel Structural Members*, including 2004 Supplement (NAS-01)
- 2009 IBC – *North American Specification for the Design of Cold-Formed Steel Structural Members* (S100-07)
- 2012 IBC – *North American Specification for the Design of Cold-Formed Steel Structural Members*, with Supplement 2 (S100-07/S2-10)
- 2015 IBC – *North American Specification for the Design of Cold-Formed Steel Structural Members* (S100-12)

### 2.0 PRODUCT USE

Simpson Strong-Tie Connectors for Cold-Formed Steel (CFS) Construction may be used as CFS framing connectors in accordance with IBC Section [104.11](#), Section [2211.1](#) of the 2015 and 2012 IBC, and Section [2210.1](#) of the 2009 and 2006 IBC. Hold-down, hurricane tie, and bracing products in this report may also be used in structures regulated under the IRC when their tabulated capacity exceeds that prescribed by the IRC or when an engineered design is submitted in accordance with Section R301.1.3 of the IRC.

### 3.0 PRODUCT DESCRIPTION

#### 3.1 Product information

**3.1.1 S/HDS and S/HDB Hold-downs:** S/HD series hold-downs are used to anchor CFS or structural steel member(s) to foundations or to connect upper story to lower story CFS or structural steel member(s) (floor-to-floor ties). They are also used for anchoring concrete and masonry walls to CFS or structural steel member(s) to provide lateral support for the walls in accordance with IBC Sections 1604.8.1 and 1604.8.2.

When regulated under the IRC, the hold-down connectors may also be used when their tabulated ASD load exceeds that required by 2012 and 2009 IRC Section [R603.9.4.2](#) (2006 IRC Section [R603.7.2](#)) or when an engineered design is submitted in accordance with Section R301.1.3 of the IRC.

S/HDS series hold-downs use self-tapping screws to attach to the CFS or structural steel member(s). S/HDB series hold-downs use bolts to attach to the CFS or structural steel member(s). A round steel standard plate (W) washer conforming to [ASME B18.22.1](#), Type A, shall be installed between the bolt nut and the framing member.

Hold-down bodies for S/HD8S, S/HD10S, S/HD8B and S/HD10B are cold-formed from No. 10 gage steel. S/HD15S and S/HD15B bodies are cold-formed from No. 7 gage steel. Base plates for all models are fabricated from 1/2 inch (12.7 mm) thick steel. [Figure 1](#), [Table 1A](#) and [Table 1B](#) of this report provide dimensions, required fasteners, and ASD and LRFD loads.

**3.1.2 S/HDU Hold-downs:** S/HDU series hold-downs are used to anchor CFS or structural steel member(s) to foundations or to connect upper story to lower story CFS or structural steel member(s) (floor-to-floor ties). The connectors also are used for anchoring concrete and masonry walls to CFS or structural steel member(s) to provide lateral support for the walls in accordance with IBC Sections 1604.8.1 and 1604.8.2.





When regulated under the IRC, the hold-down connectors may also be used when their tabulated ASD load exceeds that required by 2012 and 2009 IRC Section R603.9.4.2 (2006 IRC Section R603.7.2) or when an engineered design is submitted in accordance with Section R301.1.3 of the IRC.

S/HDU hold-downs consist of pre-deflected bodies formed from No. 10 gage galvanized steel, and a base washer fabricated from No. 3 gage steel. S/HDU series hold-downs use self-tapping screws to attach to the CFS or structural steel member(s). [Figure 2](#) and [Table 2](#) of this report provide dimensions, required fasteners, and ASD and LRFD loads.

**3.1.3 S/LTT Light Tension Ties:** S/LTT series light tension ties are used to anchor CFS member(s) to foundations or to connect upper story to lower story CFS member(s) (floor-to-floor ties). The connectors are also used for anchoring concrete and masonry walls to CFS member(s) to provide lateral support for the walls in accordance with IBC Section 1604.8.

S/LTT light tension ties consist of a steel strap component with a 90 degree angle bend at the end and a base plate component installed in the bend. The body of the S/LTT20 is formed from No.12 gage galvanized steel. Base plate component for S/LTT's is No. 3 gage galvanized steel. [Figure 3](#) and [Table 3](#) of this report provide product dimensions, required fasteners, and ASD and LRFD loads.

**3.1.4 S/DTT2Z Deck Tension Ties:** S/DTT2Z deck tension ties are used to anchor CFS member(s) to foundations or to connect upper story to lower story CFS member(s) (floor-to-floor ties). The connectors are also used for anchoring concrete and masonry walls to CFS member(s) to provide lateral support for the walls in accordance with IBC Section 1604.8.

The S/DTT2Z tension tie is formed from a single-piece of structural steel with pre-punched holes for installation of self-tapping screws used to connect the S/DTT2Z to CFS member(s). The embossed seat element reduces seat deformation. The S/DTT2Z is die-formed from No. 14 gage galvanized steel. A 1/2 inch (12.7 mm) diameter (1-3/8 inch (34.9 mm) OD) standard cut washer is included with the S/DTT2Z and is required between the nut and the seat. [Figure 3](#) and [Table 3](#) of this report provide product dimensions, required fasteners, and ASD and LRFD loads.

**3.1.5 S/HTT and HTT Heavy Tension Ties:** S/HTT and HTT series heavy tension ties are used to anchor CFS member(s) to foundations or to connect upper story to lower story CFS member(s) (floor-to-floor ties). The connectors are also used as anchorage of concrete and masonry walls to CFS member(s) to provide lateral support for the walls in accordance with IBC Section 1604.8.

S/HTT and HTT heavy tension ties are formed from a single piece of steel and consist of a steel strap with a four-ply

formed seat element as an anchor bolt attachment. The straight strap portion has pre-punched holes for installation of self-tapping screws used to connect the S/HTT and HTT to CFS member(s). S/HTT and HTT are die-formed from No. 11 gage galvanized steel. [Figure 3](#) and [Table 3](#) of this report provide product dimensions, required fasteners and ASD and LRFD loads.

**3.1.6 S/BA Joist Hangers:** S/BA series hangers are used to support a CFS joist. The hangers are die-formed from No. 14 gage galvanized steel. The hanger shall be attached onto CFS header sections using self-tapping screws. Alternatively, the hanger shall be attached by welding each top flange to the supporting member. [Figure 4](#) and [Table 4](#) of this report provide dimensions, required fasteners, and allowable loads.

**3.1.7 S/B & S/LBV Joist Hangers:** S/B and S/LBV series hangers may be used to support CFS joists. The hangers are formed from No. 12 gage and No. 14 gage galvanized steel for S/B and S/LBV, respectively. The hanger shall be attached onto a CFS supporting member using self-tapping screws or may have each top flange welded to the supporting member. [Figure 5](#) and [Table 5](#) of this report provide dimensions, required fasteners, and allowable loads.

**3.1.8 S/JCT & S/HJCT Joist Hangers:** S/JCT and S/HJCT hangers are used to support CFS joists. The S/JCT and S/HJCT hangers are formed from No. 14 gage and No. 12 gage galvanized steel, respectively. The hanger shall be attached onto CFS supporting member either by using self-tapping screws or by welding each top flange to the supporting member. The vertical flange of the hanger shall be fastened to the web of the joist using self-tapping screws. Alternatively, the hangers may be installed onto a supporting wood member with nails for S/JCT model series and with Simpson Strong-Tie SDS screws (for use under designs in accordance with the 2006 and 2009 IBC and IRC) for the S/HJCT model series. [Figure 6](#) and [Table 6](#) of this report provide dimensions, required fasteners, and allowable loads.

**3.1.9 TJC37 Truss Jack Connector:** TJC37 truss jack connector are used for skewed members or to connect jack trusses to girder trusses. TJC37 is formed from No. 16 gage galvanized steel and may be skewed from 0 degrees (perpendicular to the supporting member) to 67.5 degrees from the line perpendicular to the supporting member. When installing, the jack truss shall be positioned on the inside bend line with the end of the jack truss flush with the bend line. Then bend the TJC37 to the desired position. [Figure 7](#) and [Table 7](#) of this report provide dimensions, required fasteners, and allowable loads.

**3.1.10 TBD Truss Brace Diagonal:** TBD22 truss brace diagonal may be used to comply with the temporary truss bracing recommendations in SBCA Cold-Formed Steel Building Component Safety Information book. The brace is a flat strap that is formed into an A-shape as it is pulled



from the carton to provide rigidity and to prevent it sagging between the CFS trusses it braces during construction. The TBD is formed from No. 22 gage galvanized steel. [Figure 8](#) and [Table 8](#) of this report provide dimensions, required fasteners, and allowable loads.

**3.1.11 S/H1A Hurricane Tie:** S/H1A hurricane tie is used to tie a CFS rafter or truss chord to a CFS top track and wall stud. The hurricane tie is formed from No. 18 gage galvanized steel. [Figure 9](#) and [Table 9](#) of this report provide dimensions, required fasteners, and allowable loads.

**3.1.12 LSTA & MSTA Strap Ties:** LSTA and MSTA strap ties are used to provide a tension connection between two CFS members. The ties are from 9 to 36 inches (228.6 to 914.4 mm) long and are 1-¼ inches (31.2 mm) wide. Each strap has one row of staggered pre-punched holes. The straps are manufactured from various gages of galvanized steel. Allowable loads, fastener requirements, and steel thicknesses are shown in [Table 10](#) of this report. [Figure 10](#) of this report provides further information.

**3.1.13 MSTC Strap Ties:** MSTC strap ties are used to provide a tension connection between two CFS members. The ties are from 28-¼ to 77-¾ (717.6 to 1974.6 mm) inches long and are 3 inches (76.2 mm) wide. The straps have two rows of staggered pre-punched holes. They have countersunk fastener slots for a lower fastening profile, and coined edges for safer handling. The straps are manufactured from No. 16 gage and No. 14 gage of galvanized steel. Allowable loads, fastener requirements, and steel thicknesses are shown in [Table 10](#) of this report. [Figure 10](#) of this report provide further information.

**3.1.14 S/MST Strap Ties:** S/MST strap ties are used to provide a tension connection between two CFS members. They are from 27 to 72 inches (685.8 mm to 1829 mm) long and are 2-1/16 inches (52.4 mm) wide. Each strap has two rows pre-punched holes. The straps are manufactured from No. 12 gage and No. 10 gage of galvanized steel. Allowable loads, fastener requirements, and steel thicknesses are shown in [Table 10](#) of this report. [Figure 10](#) of this report provides further information.

**3.1.15 LSTI & MSTI Strap Ties:** LSTI and MSTI strap ties are used to provide a tension connection between two CFS members. The LSTI strap ties are either 49 or 73 inches (1245 or 1854 mm) long and MSTI strap ties are from 26 to 72 inches (660.4 to 1829 mm) long. The LSTI models are 3-¾ inches (95.3 mm) wide and the MSTI models are 2-1/16 inches (52.4 mm) wide. The LSTI and MSTI straps are manufactured from No. 18 gage and No. 12 gage galvanized steel, respectively. Allowable loads, fastener requirements, and steel thicknesses are shown in [Table 10](#) of this report. [Figure 10](#) of this report provides further information.

**3.1.16 ST Strap Ties:** ST strap ties are used to provide a tension connection between two CFS members. The ties are

manufactured in various widths and lengths. The straps are manufactured from various gages of galvanized steel. Allowable loads, fastener requirements, and steel thicknesses are shown in [Table 10](#) of this report. [Figure 10](#) of this report provides further information.

**3.1.17 FHA Strap Ties:** FHA strap ties are used to provide a tension connection between two CFS members. The ties have a corrugated shape with a total width of 1-7/16 inches (36.5 mm). The straps are manufactured from No. 12 gage galvanized steel. Allowable loads, fastener requirements, and steel thicknesses are shown in [Table 10](#) of this report. [Figure 10](#) of this report provides further information.

**3.1.18 HRS Heavy Strap Ties:** HRS strap ties are used to provide a tension connection between two CFS members. They are 1-3/8 inches (34.9 mm) wide. The straps are manufactured from No. 12 gage galvanized steel. Allowable loads, fastener requirements, and steel thicknesses are shown in [Table 10](#) of this report. [Figure 10](#) of this report provides further information.

**3.1.19 CS, CMST, & CMSTC Coiled Strap Ties:** CS, CMST and CMSTC Coil strap ties are used to provide a tension connection between two CFS members. The ties are packaged in a coil so that the length of strap needed can be cut from the coil. The CS straps are 1-¼ inches (31.8 mm) wide. The CMST and CMSTC straps are 3 inches (76.2 mm) wide. The CMSTC has coined edges for safer handling. The straps are manufactured from various gages of galvanized steel. Allowable loads, fastener requirements, and steel thicknesses are shown in [Table 11](#) of this report. [Figure 11](#) of this report provides further information.

**3.1.20 LTS, MTS, MTSC, HTS, & HTSC Twist Straps:** LTS, MTS, MTSC, HTS, & HTSC Twist Straps ties may be used to provide a tension connection between two CFS members. LTS light twist Strap, MTS medium twist strap, and HTS heavy twist straps have a formed bend so that the ends are oriented 90 degrees from each other. The straps are 1-¼ inches (31.8 mm) wide and the twist is located in the center of the strap, with the exception of the 30 inch (762 mm) long models. The twist straps are manufactured from various gages of galvanized steel. Allowable loads, fastener requirements, and steel thicknesses are shown in [Table 12](#) of this report. [Figure 12](#) of this report provides further information.

**3.1.21 SP4 & SP6 Stud to Track Ties:** The SP stud to track ties may be used to connect wall tracks to studs. The ties are formed from No. 20 gage galvanized steel. [Figure 13](#) and [Table 13](#) of this report provide dimensions, required fasteners, and allowable loads.

**3.1.22 SSP & DSP Stud to Track Ties:** SSP and DSP stud to track ties may be used to connect wall tracks to studs. The SSP is 1-¾ inches (34.9 mm) wide for fastening to a single stud, while the DSP is 2-¾ inches (69.9 mm) wide for fastening to double studs. The SSP and DSP are formed





from No. 18 gage galvanized steel. [Figure 14](#) and [Table 14](#) of this report provide dimensions, required fasteners, and allowable loads.

**3.1.23 TSP Stud to Track Tie:** TSP stud to track ties are used to connect wall tracks and studs. The tie has a twist so that it fastens to the side of the stud. TSP is formed from No. 16 gage galvanized steel. [Figure 14](#) and [Table 14](#) of this report provide dimensions, required fasteners, and allowable loads.

**3.1.24 LTP5 Lateral Tie Plate:** The LTP5 lateral tie plate are used to transfer shear between the top or bottom tracks to the rim joist or blocking, or between other parallel members. The LTP5 may be installed over either structural wood panel sheathing or sheet steel sheathing to connect the bottom track of a wall to the rim joist or blocking. The LTP5 lateral tie plate is manufactured from No. 20 gage galvanized steel with embossments along the length. [Figure 15](#) and [Table 15](#) of this report provide dimensions, required fasteners and allowable loads.

**3.1.25 DTC & STC Truss Clips:** DTC and STC truss clips may be used as alignment control between a roof truss and non-load-bearing walls. The 1-½ inch (38.1 mm) long slot permits vertical truss chord movement. DTC and STC connectors are formed from No. 18 gage galvanized steel. [Figure 16](#) and [Table 16](#) of this report provide dimensions, required fasteners, and allowable loads.

**3.1.26 LSUBH, SUBH and MSUBH Structural Bridging Connectors:** LSUBH, SUBH and MSUBH structural bridging connectors are used to connect cold-formed steel C-studs to bridging U-channel installed through the web punch-out of the studs. Connectors are used as bracing to restrain twisting of studs loaded in the plane of the web and to restrain lateral translation of studs loaded in compression. Typical applications include attachments between cold-formed steel studs and bridging of exterior curtain-wall systems, exterior and interior bearing wall systems, interior non-bearing wall systems, and soffit or ceiling framing systems. Connectors are used with stud depths from 3-5/8 to 8 inches (92 to 203.2 mm) utilizing cold-formed steel 1½ inch x ½ inch (38.1 mm x 12.7 mm) U-channel bridging members.

LSUBH connectors are formed from No. 20 gage steel, and the SUBH connectors are formed from No. 18 gage steel, each with a slot width that accommodates a stud web thickness of 33 mils (0.83 mm)(No. 20 gage) to 54 mils (1.37 mm) (No. 16 gage). MSUBH connectors are formed from No. 14 gage steel with a slot width that accommodates a stud web thickness of 54 mils (1.37 mm) (No. 16 gage) to 97 mils (2.46 mm) (No. 12 gage). [Figure 17](#) and [Table 17](#) of this report provide dimensions, required fasteners, allowable loads, allowable torsional moment, and brace stiffness.

## 3.2 Material information

**3.2.1 Steel:** Galvanized steel connectors described in this report are manufactured from steel complying with [ASTM A653](#) SS. Non-galvanized steel connectors comply with [ASTM A36](#) or [ASTM A1011](#). Steel used to fabricate the CFS connectors shown in this report comply with Connector Material Properties in [Table 18](#) of this report.

Connectors fabricated from steel complying with ASTM A653 have a minimum G90 zinc coating specification. Some models may also be available with either a G185 zinc coating (designated with a model number ending in the letter Z) or with a batch hot-dipped galvanized coating (designated with a model number ending with the letters HDG) with a minimum specified coating weight of 2.0 ounces of zinc per square foot of surface area (610 g/m<sup>2</sup>), total for both sides, in accordance with [ASTM A123](#). Model numbers in this report do not list the Z or HDG ending, but the information shown applies. The lumber treater and the holder of this report (Simpson Strong-Tie Company) shall be contacted for recommendations on the connectors when in contact with preservative-treated or fire-retardant treated lumber.

**3.2.2 Cold-Formed Steel Members and Structural Members:** Structural cold-formed steel framing members that are attached to the connectors shown in this report shall comply with IBC Sections 2210 and 2211 as documented in an evaluation report by IAPMO UES or another accredited evaluation service agency. Structural steel members that are attached to the connectors shown in this report shall comply with IBC Section 2205 or an evaluation report stating IBC compliance by IAPMO UES or another approved and accredited evaluation service agency.

At a minimum, the material specification for structural cold-formed steel framing members that are attached to the connectors shown in this report shall comply with [ASTM A1003](#). Loads in this report are based on CFS members with a minimum yield strength,  $F_y$ , of 33 ksi (228 MPa) and a minimum tensile strength,  $F_u$ , of 45 ksi (310 MPa) for 43 mil (1.09 mm) (No. 18 gage) and thinner and a minimum yield strength,  $F_y$ , of 50 ksi (345 MPa) and a minimum tensile strength,  $F_u$ , of 60 ksi (414 MPa) for 54 mil (1.37 mm) (No. 16 gage) and thicker.

Cold-formed steel 1½ inch x ½ inch U-channel (38.1 mm x 12.7 mm) bridging member used with SUBH and MSUBH bridging connectors shall have a minimum base metal thickness of 0.0566 in. (1.43 mm) with a minimum of yield strength of 33 ksi (228 MPa) and a minimum tensile strength of 45 ksi (310 MPa)

Use of the connectors in this report with materials not meeting the requirements of this section is outside the scope of this report.



**3.2.3 Wood:** Wood members with which the connectors are used shall be either sawn lumber or engineered lumber having a minimum specific gravity of 0.50 (minimum equivalent specific gravity of 0.50 for engineered lumber), and having a maximum moisture content of 19 percent (maximum 16 percent for engineered lumber). The thickness (depth) of the wood main member shall be equal to or greater than the length of the fasteners specified in the tables in this report, unless the reduced penetration effect on the load calculation per the applicable National Design Specification for Wood Construction and its Supplement (ANSI/AWC NDS) is taken into account, or as required by wood member design, whichever is greater.

**3.2.4 Fasteners:** At a minimum, bolts shall comply with [ASTM F1554](#) Grade 36 or [A307](#).

SDS screws shall comply with ICC-ES [ESR-2236](#).

Self-tapping screw fasteners for steel-to-steel connections shall comply with [ASTM C1513](#) or evaluated for compliance to the IBC in an evaluation report by IAPMO UES or another accredited evaluation service agency. Self-tapping screw fasteners shall extend through the steel connection a minimum of three (3) exposed threads in accordance with [AISI S200](#), General Provisions. The self-tapping screw fasteners used for connectors in this report shall comply with the following tabulated nominal diameters:

FASTENER	NOMINAL DIA. (in.)
No. 8	0.164
No. 10	0.190
No. 14	0.242
1/4"	0.250

For SI: 1 inch = 25.4 mm, 1 psi = 6.895 kPa.

Nails used for connectors described in this report shall comply with [ASTM F1667](#) and have the following minimum fasteners dimensions and bending yield strengths ( $F_{yb}$ ):

FASTENER	SHANK DIA (in.)	FASTENER LENGTH (in.)	$F_{yb}$ (psi)
8d x 1 1/2	0.131	1 1/2	100,000
10d	0.148	3	90,000

For SI: 1 inch = 25.4 mm, 1 psi = 6.895 kPa

Fasteners used in contact with preservative-treated or fire-retardant-treated lumber shall, as a minimum, comply with IBC Section 2304.9.5, or IRC Section R317.3 (2006 IRC Section [R319.3](#)), as applicable. SDS screws used in contact with preservative-treated or fire-retardant-treated lumber shall comply with ICC-ES [ESR-2236](#). The lumber treator or this report holder (Simpson Strong-Tie), or both, should be contacted for recommendations on the minimum corrosion

resistance protection of fasteners and connection capacities of fasteners used with the specific proprietary preservative-treated or fire-retardant-treated lumber.

## 4.0 DESIGN AND INSTALLATION

### 4.1 Design

**4.1.1 General:** The loads shown in the tables of this report for cold-formed steel (CFS) members are based on Allowable Stress Design (ASD) and Load and Resistance Factor Design (LRFD) determined in accordance with the [AISI S100](#) Specification.

**4.1.2** Tabulated allowable strength design (ASD) loads for the connectors in this report are based on the least value of the following criterion unless otherwise noted:

1. Average test load under which 1/8 inch (3.2 mm) deflection occurs.
2. Average ultimate test load, divided by a safety factor,  $\Omega$ , determined in accordance with the AISI S100 Specification Chapter F.
3. Allowable loads for welds and allowable lateral loads for bolts, or screws for steel to steel connections calculated in accordance with the AISI Specification Section E2, E3 and E4, respectively.

**4.1.3** Tabulated Load Resistance Factor Design (LRFD) loads for the hold-down connectors ([Table 1A](#), [1B](#), [2](#) and [3](#) of this report) in this report are based on the least value of the following criterion:

1. Average test load under which 1/4 inch (6.4 mm) deflection occurs.
2. Average ultimate test load, multiplied by the resistance factor,  $\Phi$ , determined in accordance with the AISI S100 Specification Chapter F.
3. Design strength for welds and the lateral design strength for bolts or screws for steel-to-steel connections calculated in accordance with the AISI Specification Section E2, E3 and E4, respectively.

**4.1.4** Tabulated allowable strength design (ASD) loads for the LSUBH, SUBH and MSUBH structural bridging connectors in this report are based on the average ultimate test load divided by a safety factor,  $\Omega$ , determined in accordance with the AISI S100 Specification, Chapter F. For the design of axially loaded studs, the tabulated brace stiffness shall also be considered in accordance with the stiffness requirements given in section D3.3 of the AISI S100 Specification. The tabulated brace stiffness is based on 10 percent of nominal axial load. Allowable torsional moment, brace strength, and brace stiffness tabulated in



Table 17 of this report are for use with Section D3.2.1 and D3.3 of the AISI S100 Specification.

Connected cold-formed steel members shall be analyzed for load carrying capacity at the connection in accordance with the AISI S100 Specification.

For connectors attached to wood members, the allowable loads shown in this report are based on allowable stress design and include the load duration factor,  $C_D$ , corresponding with the applicable loads in accordance with the National Design Specification for Wood Construction and its supplement (ANSI/AWC NDS).

Tabulated allowable loads apply to products connected to wood used under dry conditions and where sustained temperatures are 100°F (37.8°C) or less. When products are installed to wood having a moisture content greater than 19 percent (16 percent for engineered wood products), or where wet service is expected, the allowable tension loads shall be adjusted by the wet service factor,  $C_M$ , specified in the ANSI/AWC NDS. When connectors are installed in wood that will experience sustained exposure to temperatures exceeding 100°F (37.8°C), the allowable loads in this report shall be adjusted by the temperature factor,  $C_t$ , specified in the ANSI/AWC NDS.

Connected wood members shall be analyzed for load carrying capacity at the connection in accordance with ANSI/AWC NDS.

Design of wood or steel members fastened to bolt or screw hold-down devices shall consider combined stresses due to axial tension and flexural bending induced by eccentricity in the connection. Stresses shall be evaluated at the critical net section.

Connections (e.g., hold-downs) of a discontinuous system (e.g., shear wall) to the supporting member (e.g., beam) shall comply with ASCE 7 Section 12.3.3.3. Additional drift may occur, depending on the type of supporting member that is used, and shall be considered by the registered design professional.

## 4.2 Installation

Installation of the connectors shall be in accordance with this evaluation report and the manufacturer's published installation instructions. In the event of a conflict between this report and the manufacturer's published installation instructions, the more restrictive governs.

## 4.3 Special Inspection

**4.3.1** A statement of special inspection shall be prepared by the registered design professional in responsible charge and submitted to the code official for approval when required by Section 1704.3 of the 2015 and 2012 IBC and 2009 (2006)

IBC Section 1705. A statement of responsibility shall be submitted by each responsible contractor to the code official for approval when required by 2015 and 2012 IBC Section 1704.4, 2009 IBC Section 1709 or 2006 IBC Section 1706.

**4.3.2** Periodic special inspection shall be conducted when connectors are components within the main wind-force-resisting system of structures constructed in areas listed in the 2015 and 2012 IBC Section 1705.10, 2009 IBC Section 1706.1, or 2006 IBC Section 1705.4. Special inspection requirements do not apply to structures, or portions thereof, that qualify for an exception pursuant to 2015 IBC Sections 1704.2, 1705.3, 1705.11.1, 1705.11.2, 2012 IBC Sections 1704.2, 1705.3, 1705.10.1, 1705.10.2, 2009 IBC Sections 1704.1, 1704.4, 1706.2, 1706.3, or 2006 IBC Section 1704.1 and 1704.4.

**4.3.3** Periodic special inspection for seismic resistance shall be conducted in accordance with 2012 IBC Section 1705.11 or 2009 (2006) Section 1707 where required. Special inspection requirements for seismic resistance do not apply to structures, or portions thereof, that qualify for an exception pursuant to 2015 IBC Sections 1704.2, 1705.3, 1705.12, 1705.12.3, 2012 IBC Sections 1704.2, 1705.3, 1705.11, 1705.11.3, 2009 or 2006 IBC Sections 1704.1, 1704.4, 1705.3, 1707.3 or 1707.4.

**4.3.4** For installations under the IRC, special inspection is not normally required. However, for an engineered design where calculations are required to be signed by a registered design professional, periodic special inspection requirements and exemptions are as stated in Sections 4.3.2 and 4.3.3 of this report as applicable for installations under the IRC.

## 5.0 LIMITATIONS

The Simpson Strong-Tie products described in this report comply with, or are suitable alternatives to what is specified in those codes listed in Section 1.0 of this report subject to the following conditions:

**5.1** Connectors shall be manufactured, identified and installed in accordance with this report and the manufacturer's published installation instructions. Where conflicts occur, the more restrictive governs. A copy of the instructions shall be available at the jobsite at all times during installation.

**5.2** Calculations showing compliance with this report shall be submitted to the code official. The calculations shall be prepared by a registered design professional where required by the statutes of the jurisdiction in which the project is to be constructed.

**5.3** Adjustment factors noted in Section 4.1 of this report and the applicable codes shall be applied to allowable loads when warranted by the service conditions.



5.4 Connected steel members, connected wood members and fasteners shall comply, respectively, with Sections 3.2.2, 3.2.3 and 3.2.4 of this report.

5.5 Use of connectors with preservative treated or fire-retardant-treated lumber shall be in accordance with Section 3.2.1 of this report. Use of fasteners with preservative-treated or fire-retardant-treated lumber shall be in accordance with Section 3.2.4 of this report.

5.6 Simpson Strong-Tie Connectors for Cold-Formed Steel (CFS) Construction are fabricated at Simpson Strong-Tie facilities under a quality control program that meets or exceeds the Minimum Requirements for IAPMO UES Listee's Quality Assurance System

### 6.0 SUBSTANTIATING DATA

Data in accordance with the ICC-ES Acceptance Criteria for Connectors Used With Cold-Formed Steel Structural Members (AC261), approved October 2011, editorially revised May 2015. Test results are from laboratories in compliance with [ISO/IEC 17025](http://www.iso.org/iso/iec17025).

### 7.0 IDENTIFICATION

A label shall be affixed on at least one of the following: product, packaging, installation instructions or descriptive literature. The label shall include the company name or trademark, model number, and the IAPMO Uniform ES Mark of Conformity the name of the inspection agency (when applicable) and the Evaluation Report Number (ER-124) to identify the products recognized in this report. A die-stamp label may also substitute for the label. Either Mark of Conformity may be used as shown below:

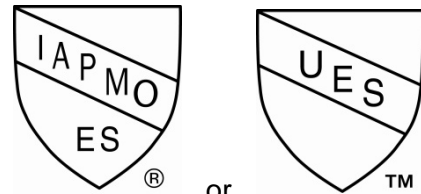

**IAPMO UES ER #124**

**Brian Gerber, P.E., S.E.**  
Vice President, Technical Operations  
Uniform Evaluation Service

**Richard Beck, PE, CBO, MCP**  
Vice President, Uniform Evaluation Service

**GP Russ Chaney**  
CEO, The IAPMO Group

For additional information about this evaluation report please visit [www.uniform-es.org](http://www.uniform-es.org) or email us at [info@uniform-es.org](mailto:info@uniform-es.org)





**TABLE 1A – TENSION LOADS AND DISPLACEMENTS FOR S/HDS AND S/HDB SERIES HOLD-DOWNS**

Model	Height (in)	Fasteners		Framing Member(s) <sup>5</sup> No.-Mil (ga)	ASD		LRFD		Nominal Tension Load <sup>8</sup> (lbs)
		Anchor Bolt Dia. <sup>1,2</sup> (in)	Framing Fasteners		Tension Load (lbs)	Displacement at ASD Load <sup>7</sup> (in)	Tension Load (lbs)	Displacement at LRFD Load <sup>7</sup> (in)	
S/HD8S	11	7/8	17 - #14 Screws <sup>3</sup>	2-33 (2-20ga)	7335	0.120	11715	0.204	13720
				2-43 (2-18ga)	8750	0.086	13975	0.146	21435
				2-54 (2-16ga)	8855	0.106	14145	0.162	21700
				1-97 (1-12ga) PACO <sup>6</sup>	11030	0.091	17620	0.146	27025
				Steel Fixture	10840	0.053	17335	0.072	32525
S/HD10S	13½	7/8	22 - #14 Screws <sup>3</sup>	2-33 (2-20ga)	7400	0.122	11815	0.192	13835
				2-43 (2-18ga)	11120	0.112	17755	0.124	20795
				2-54 (2-16ga)	12220	0.096	19520	0.145	29940
				1-97 (1-12ga) PACO <sup>6</sup>	14840	0.085	23705	0.148	34135
				Steel Fixture	12375	0.043	19820	0.061	33535
S/HD15S	17	1	30 - #14 Screws <sup>3</sup>	2-43 (2-18ga)	12110	0.096	19340	0.164	22645
				2-54 (2-16ga)	13500	0.110	21565	0.130	33075
				1-97 (1-12ga) PACO <sup>6</sup>	16420	0.078	26230	0.135	40230
				Steel Fixture	15810	0.043	25320	0.065	42845
S/HD8B	11	7/8	2 - ¾" Dia. Bolts <sup>4</sup>	2-33 (2-20ga)	3895	0.081	5620	0.144	8645
				2-43 (2-18ga)	5345	0.098	7710	0.146	11865
				2-54 (2-16ga)	8950	0.082	14280	0.141	20310
				1-97 (1-12ga) PACO <sup>6</sup>	8090	0.088	12905	0.167	18370
				Steel Fixture	9080	0.069	14545	0.104	22975
S/HD10B	13½	7/8	3 - ¾" Dia. Bolts <sup>4</sup>	2-33 (2-20ga)	5840	0.070	8430	0.124	12970
				2-43 (2-18ga)	8015	0.087	11565	0.120	17795
				2-54 (2-16ga)	12090	0.125	19720	0.230	28050
				1-97 (1-12ga) PACO <sup>6</sup>	13385	0.912	19355	0.119	28905
				Steel Fixture	15635	0.102	24955	0.123	35495
S/HD15B	17	1	4 - ¾" Dia. Bolts <sup>4</sup>	2-43 (2-18ga)	10690	0.118	15425	0.179	22165
				2-54 (2-16ga)	16020	0.090	25565	0.121	36360
				1-97 (1-12ga) PACO <sup>6</sup>	17850	0.103	25805	0.130	39700
				Steel Fixture	18690	0.104	29825	0.139	42425

For SI: 1 inch = 25.4 mm, 1 lb = 4.45 N.

- The Designer shall specify the foundation anchor material type, embedment and configuration. Some of the tabulated hold-down tension loads exceed the tension strength of typical [ASTM F1554](#) Grade 36 or [A307](#) anchor bolts.
- A foundation anchor bolt washer is not required.
- 1/4-inch diameter self-tapping screws may be substituted for #14 self-tapping screws.
- A round steel standard plate washer conforming to Section 3.1.1 of this report is required to be installed between the framing member bolt nut and the framing member for the S/HDB series hold-downs.
- The Designer shall specify and detail the connection of the back-to-back full height framing members.
- PACO columns are manufactured by PACO Steel & Engineering Corp. Recognition of the column is beyond the scope of this report.
- Hold-down displacement at tabulated ASD and LRFD loads is the difference in the displacement measured between the anchor bolt and back of the hold-down that's attached to the framing member(s) when loaded to the ASD and LRFD static test load, respectively. Deflection includes fastener slip, hold-down elongation and anchor bolt elongation (L=4 inches).
- The Nominal Tension Load is the average ultimate (peak) load taken from tests in accordance with [AISI S100](#) Chapter F. When hold-downs are used in CFS framed shear walls or diagonal strap braced walls with an R-coefficient greater than 3, the [AISI S213](#) Lateral Design Section C5 requires hold-downs in shear walls have the nominal strength to resist the lesser of the amplified seismic load or the load the system can deliver and hold-downs in diagonal strap braced walls have the nominal strength to resist the lesser of the amplified seismic load or the expected yield strength of the diagonal strap bracing member.

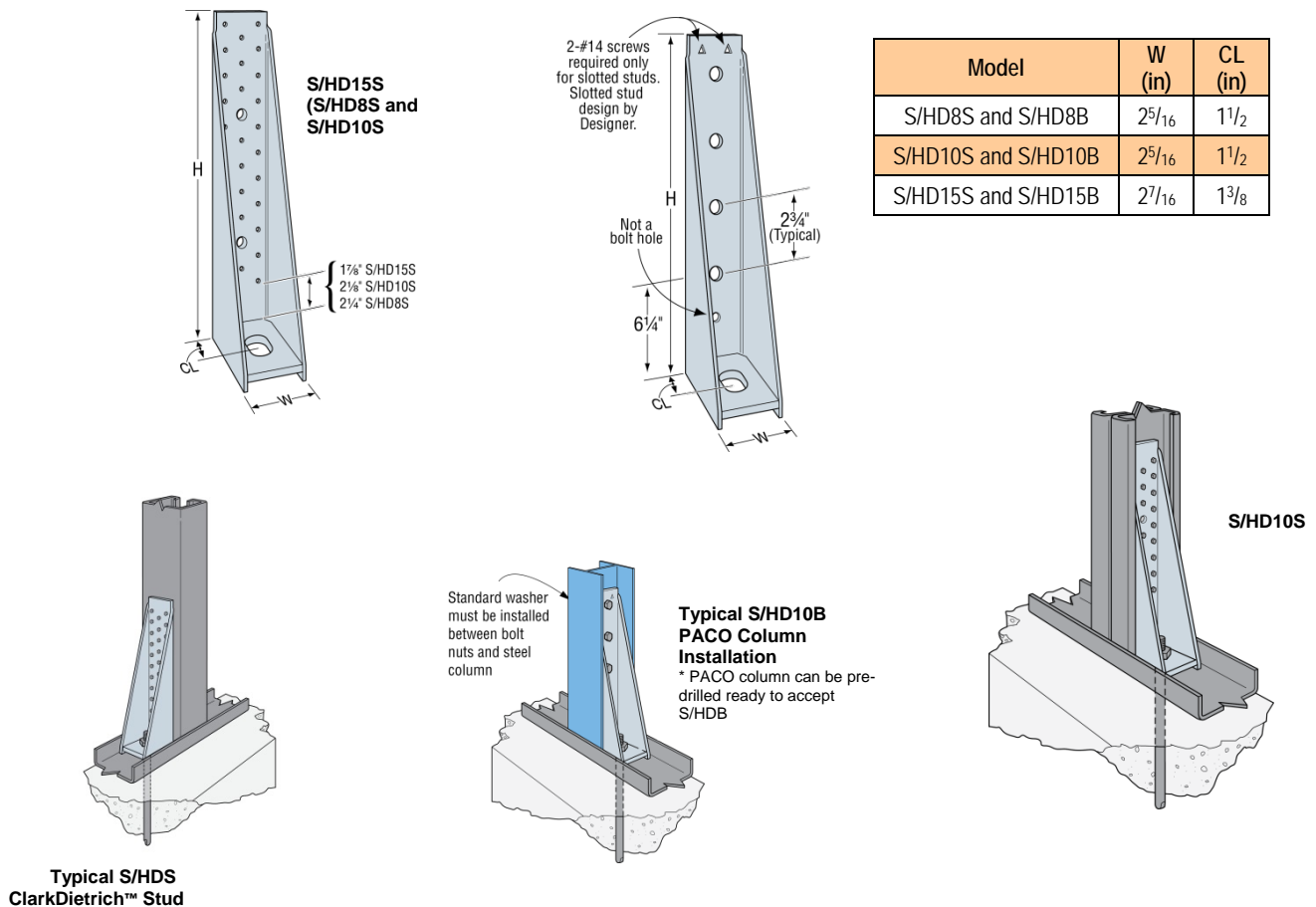

**TABLE 1B – TENSION LOADS FOR S/HDS SERIES HOLD-DOWNS ATTACHED TO CLARKDIETRICH™ HDS® STUD<sup>1</sup>**

Model	Height (in)	Fasteners		ClarkDietrich HDS Stud Thickness <sup>2</sup> mil (ga)	ASD		LRFD		Nominal Tension Load <sup>8</sup> (lbs)
		Anchor Bolt Dia. (in)	Stud Fasteners		Tension Load (lbs)	Displacement at ASD Load <sup>7</sup> (in)	Tension Load (lbs)	Displacement at LRFD Load <sup>7</sup> (in)	
S/HD8S	11	7/8	17 - #14	33 (20ga)	3080	0.075	4920	0.124	5760
				43 (18ga)	4125	0.101	6590	0.177	7720
				54 (16ga)	7285	0.098	11160	0.173	13925
				68 (14ga)	7285	0.085	11160	0.141	17855
				97 (12ga)	10065	0.100	16075	0.147	24655
S/HD10S	13½	7/8	22 - #14	43 (18ga)	5060	0.059	8085	0.100	9465
				54 (16ga)	8675	0.095	13855	0.162	16220
				68 (14ga)	8840	0.088	14120	0.147	21655
				97 (12ga)	12225	0.088	19530	0.143	29955
S/HD15S	17	1	30 - #14	68 (14ga)	13495	0.087	21550	0.147	25235
				97 (12ga)	14025	0.096	22400	0.142	34355

For SI: 1 inch = 25.4 mm, 1 lb = 4.45 N.

- Footnotes under [Table 1A](#) of this report apply, excluding footnotes 4, 5 and 6.
- HDS stud manufactured by ClarkDietrich™ Building Systems. ICC-ES [ESR-1166P](#) contains applicable details.



**FIGURE 1 – S/HDS AND S/HDB HOLD-DOWNS**

**TABLE 2 – TENSION LOADS AND DISPLACEMENTS FOR S/HDU SERIES HOLD-DOWNS**

Model	Height (in.)	Fasteners		Framing Member(s) <sup>5</sup> No.-mil (ga)	ASD		LRFD		Nominal Tension Load <sup>7</sup> (lbs)
		Anchor Bolt Dia <sup>1,2</sup> (in)	Framing Fasteners <sup>4</sup>		Tension Load (lbs)	Displacement at ASD Load <sup>6</sup> (in)	Tension Load (lbs)	Displacement at LRFD Load <sup>6</sup> (in)	
S/HDU4	7 <sup>7</sup> / <sub>8</sub>	5/8	6-#14	2-33 (2-20ga)	2320	0.093	3705	0.149	5685
				2-43 (2-18ga)	3825	0.115	6105	0.190	9365
				2-54 (2-16ga)	3970	0.093	6345	0.156	9730
				Steel Fixture	4470	0.063	7165	0.103	12120
S/HDU6	10 <sup>3</sup> / <sub>8</sub>	5/8	12-#14	2-33 (2-20ga)	4895	0.125	8495	0.250	10470
				2-43 (2-18ga)	6125	0.119	9690	0.250	15460
				2-54 (2-16ga)	6125	0.108	9785	0.234	15005
				Steel Fixture	5995	0.060	9580	0.136	14695
S/HDU9	12 <sup>7</sup> / <sub>8</sub>	7/8	18-#14	2-33 (2-20ga)	6965	0.103	11125	0.189	13165
				2-43 (2-18ga)	9255	0.125	15485	0.250	21810
				2-54 (2-16ga)	9990	0.106	15960	0.225	24480
				Steel Fixture	12715	0.125	20510	0.177	31455
S/HDU11	16 <sup>5</sup> / <sub>8</sub>	7/8 <sup>3</sup>	27-#14	2-33 (2-20ga)	6965	0.103	11125	0.189	13165

For SI: 1 inch = 25.4 mm, 1 lb = 4.45 N.

- The Designer shall specify the foundation anchor material type, embedment and configuration. Some of the tabulated hold-down tension loads exceed the tension strength of typical ASTM F1554 Grade 36 or A307 anchor bolts.
- A foundation anchor bolt washer is not required.
- A heavy hex nut for the anchor bolt is required to achieve the tabulated loads for S/HDU11.
- 1/4-inch self-tapping screws may be substituted for #14 self-tapping screws.
- The Designer shall specify and detail the connection of the back-to-back full height framing members.
- Hold-down displacement at tabulated ASD and LRFD loads is the difference in the displacement measured between the anchor bolt and back of the hold-down that's attached to the framing member(s) when loaded to the ASD and LRFD static test load, respectively. Deflection fastener slip, hold-down elongation and anchor bolt elongation (L=4").
- The Nominal Tension Load is the average ultimate (peak) load from tests in accordance with AISI S100 Chapter F. When hold-downs are used in CFS framed shear walls or diagonal strap braced walls with an R-coefficient greater than 3, the AISI S213 Lateral Design Section C5 requires hold-downs in shear walls have the nominal strength to resist the lesser of the amplified seismic load or the load the system can deliver and hold-downs in diagonal strap braced walls have the nominal strength to resist the lesser of the amplified seismic load or the expected yield strength of the diagonal strap bracing member.

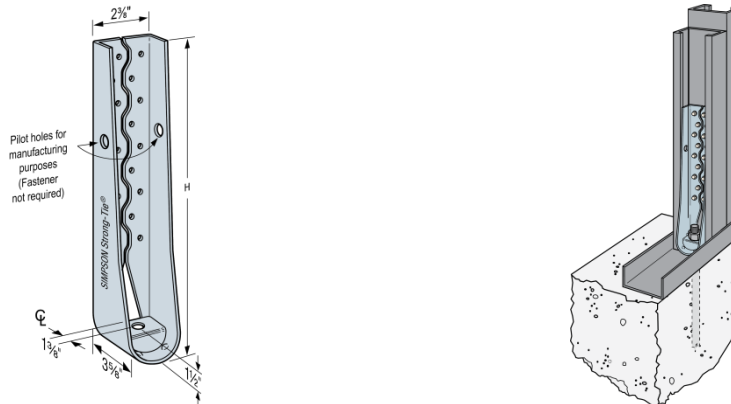

**FIGURE 2 – S/HDU HOLD-DOWN**

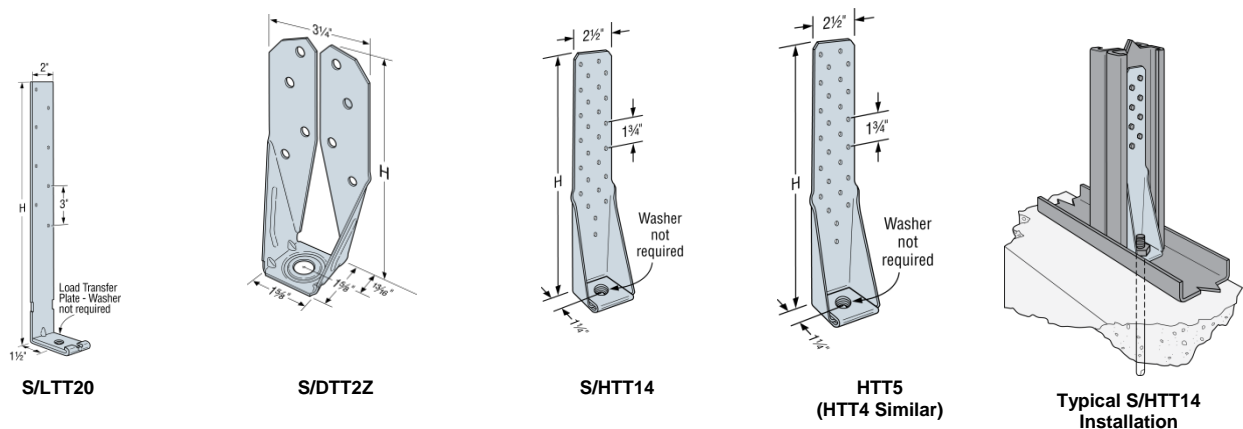

**TABLE 3 – TENSION LOADS AND DISPLACEMENTS FOR S/LTT, S/DTT, S/HTT, AND HTT SERIES HOLD-DOWNS<sup>1</sup>**

Model	Height (in)	Fasteners		Framing Member(s) <sup>3</sup> No.-mil (ga)	ASD		LRFD		Nominal Tension Load <sup>5</sup> (lbs)
		Anchor Bolt Dia. <sup>2</sup> (in)	Framing Fasteners		Tension Load (lbs)	Displacement at ASD Load <sup>4</sup> (in)	Tension Load (lbs)	Displacement at LRFD Load <sup>4</sup> (in)	
S/LTT20	20	1/2	8 - #10	1-33 (1-20ga)	1200	0.125	1890	0.250	4625
S/DTT2Z	615/16	1/2	8-#14	1-33 (1-20ga)	1570	0.138	2200	0.250	4265
				1-43 (1-18ga)	1685	0.151	2355	0.250	5570
				2-33 (2-20ga)	1735	0.153	2430	0.250	5735
S/HTT14	15	5/8	16 - #10	1-33 (1-20ga)	2775	0.108	4430	0.172	6800
				2-33 (2-20ga)	3850	0.125	6700	0.250	11590
HTT4	12 <sup>3/8</sup>	5/8	18 - #10	1-33 (1-20ga)	3180	0.104	4770	0.187	8215
				2-33 (2-20ga)	4395	0.125	6675	0.250	11835
HTT5	16	5/8	26 - #10	1-43 (1-18ga)	4240	0.125	6505	0.250	11585
				2-43 (2-18ga)	4670	0.125	6970	0.250	12195
				1-54 (1-16ga)	4150	0.125	6425	0.250	12365

For SI: 1 inch = 25.4 mm, 1 lb = 4.45 N.

- The Designer shall specify the foundation anchor material type, embedment and configuration.
- Foundation anchor bolt washer is not required.
- The Designer shall specify and detail the connection of the back-to-back full height studs.
- Hold-down displacement at tabulated ASD and LRFD loads is the difference in the displacement measured between the anchor bolt and back of the hold-down that's attached to the framing member(s) when loaded to the ASD and LRFD static test load, respectively. Deflection fastener slip, hold-down elongation and anchor bolt elongation (L=4 inches).
- The Nominal Tension Load is the average ultimate (peak) load from tests in accordance with AISI S100 Chapter F. When hold-downs are used in CFS framed shear walls or diagonal strap braced walls with an R-coefficient greater than 3, the AISI S213 Lateral Design Section C5 requires hold-downs in shear walls have the nominal strength to resist the lesser of the amplified seismic load or the load the system can deliver and hold-downs in diagonal strap braced walls have the nominal strength to resist the lesser of the amplified seismic load or the expected yield strength of the diagonal strap bracing member.



**FIGURE 3 – S/LTT, S/DTT, S/HTT AND HTT HOLD-DOWNS**



**TABLE 4 – ALLOWABLE LOADS FOR THE S/LBV & S/B SERIES JOIST HANGERS<sup>1,2,3</sup>**

Model No.	Dimensions (in)		Fasteners		Allowable Downloads <sup>4</sup> (lbs)
	B	TF	Top	Joist	
S/BA - Screw	3	2 1/2	6 - #10 screws	1 - #10	3475
S/BA - Weld			4 - 1/8" x 2" fillet weld	1 - #10	2920

For SI: 1 inch = 25.4 mm, 1 lb = 4.45 N.

1. Designer shall insure that the joist member adequately transfers load to the hanger.
2. CFS / Steel Beam header must be braced to prevent buckling per Designer specification.
3. S/BA may be used for weld-on applications; a minimum of 1/4 inch x 2 inch fillet weld on each top flange (4 welds total) is required. Distribute the weld equally on both top flanges. Consult the code for special considerations when welding galvanized steel.
4. Loads are based on the supporting member providing a minimum 2-1/2 inch bearing area for the S/BA top flange (TF) as well as a minimum CFS header and a minimum 68 mil (14ga) joist thickness.

S/BA Series Model No.	W (in)	H (in)
S/BA2.12/8	2 1/8	8
S/BA2.12/10		10
S/BA2.12/12		12
S/BA2.12/14		14
S/BA4.18/8	4 3/16	8
S/BA4.18/10		10
S/BA4.18/12		12
S/BA4.18/14		14

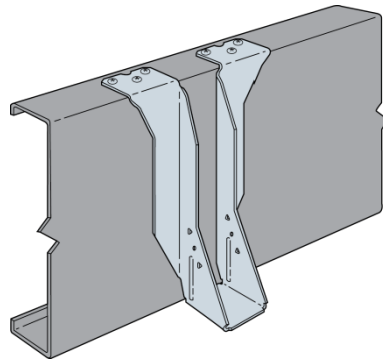
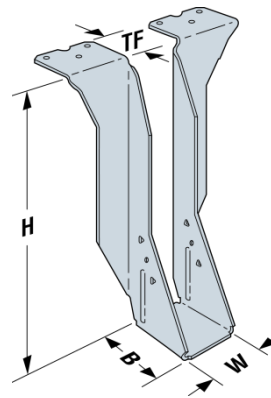

**S/BA Installation to a CFS Header**

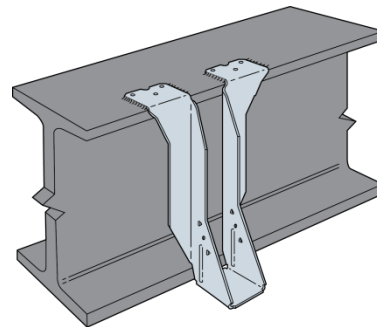

**S/BA Weld-on Applications**

**FIGURE 4 – S/BA JOIST HANGER**





**TABLE 5 – ALLOWABLE LOADS FOR THE S/LBV & S/B SERIES JOIST HANGERS<sup>1,2,3,4</sup>**

Model No.	Dimensions (in)			Fasteners			Allowable Loads (lbs)		
	W	H	B	Top	Face	Joist	Uplift	Download	
							97 mil (12 ga)	97 mil (12 ga)	Welded
S/B	See Table	6 to 30	3 to 5	8-#10	4-#14	3-#14	1855	5970	-
S/B - Skew				8-#10	4-#14	3-#14	1855	4195	-
S/B - Weld				Weld	-	3-#14	-	-	5755

Model No.	Dimensions (in)			Fasteners			Allowable Loads (lbs)		
	W	H	B	Top	Face	Joist	Uplift	Download	
							68 mil (14 ga)	68 mil (14 ga)	Welded
S/LBV	See Table	6 to 20	2-1/4	4-#10	2-#10	3-#10	1010	3150	-
S/LBV - Skew				4-#10	2-#10	3-#10	1010	2220	-
S/LBV - Weld				Weld	-	3-#10	-	-	2965

S/B Series Model No.	S/LBV Series Model No.	Width (inch)
S/B1.56	S/LBV1.56	1 9/16
S/B1.81	S/LBV1.81	1 13/16
S/B2.06	S/LBV2.06	2 1/16
S/B2.37	S/LBV2.37	2 3/8
S/B2.56	S/LBV2.56	2 9/16
S/B2.68	S/LBV2.68	2 11/16
S/B3.12	S/LBV3.12	3 1/8
S/B3.56	S/LBV3.56	3 9/16
S/B3.62	S/LBV3.62	3 5/8
S/B4.06	S/LBV4.06	4 1/16
S/B4.12	S/LBV4.12	4 1/8
S/B4.28	S/LBV4.28	4 9/32
S/B4.75	S/LBV4.75	4 3/4
S/B5.50	S/LBV5.50	5 1/2

1. Designer shall insure that the joist member adequately transfers load to the hanger.
2. Steel header must be braced to prevent buckling per Designer specification.
3. S/LBV and S/B may be used for weld-on applications; a minimum of 1/2 inch x 2 inch fillet weld on each top flange is required. Distribute the weld equally on both top flanges. Consult the code for special considerations when welding galvanized steel. Uplift loads do not apply.
4. S/LBV and S/B series can be skewed to a maximum of 45°.

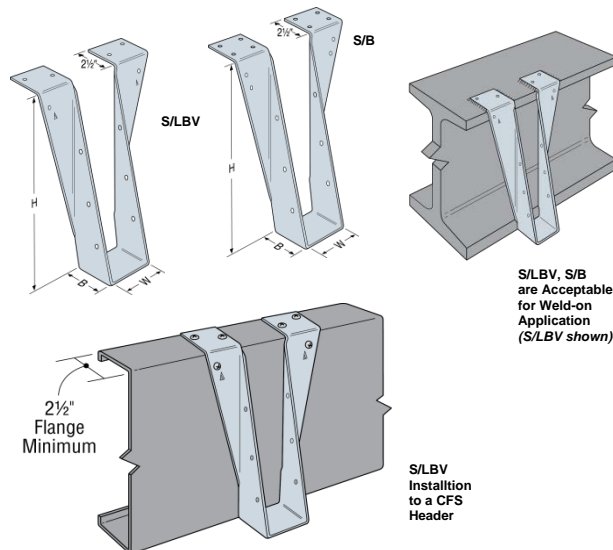

**FIGURE 5 – S/LBV & S/B JOIST HANGERS**

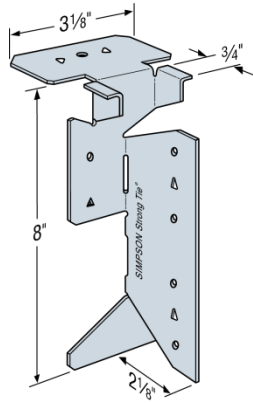

**TABLE 6 – ALLOWABLE LOADS FOR THE S/HJCT & S/JCT SERIES JOIST HANGERS**

Model No.	Steel Header <sup>3,4</sup>				
	Fasteners <sup>5</sup>			Allowable Load <sup>1</sup> (lbs)	
	Top	Face	Joist	Uplift	Download
<b>Straight Hanger</b>					
S/JCT (min)	1-#10	2-#10	4-#10	940	1195
S/JCT (max)	1-#10	4-#10	6-#10	1435	2105
S/HJCT (min)	2-#10	4-#14	6-#14	1510	2920
S/HJCT (max)	2-#10	8-#14	9-#14	1670	3855
<b>Skewed Hanger</b>					
S/JCT (min)	1-#10	2-#10	4-#10	940	1135
S/JCT (max)	1-#10	4-#10	6-#10	940	1185
S/HJCT	2-#10	4-#10	6-#14	1510	2305
<b>Welded Hanger<sup>6</sup></b>					
S/JCT	1/8" x 2 1/2" fillet weld to each side of top flange		4-#10	-	940
S/HJCT			4-#14	-	1450
S/HJCT Skew			4-#14	-	1235
Model No.	Wood Header				
	Fasteners			Allowable Load <sup>2</sup> (lbs)	
	Top	Face	Joist	Uplift C <sub>D</sub> = 1.6	Download C <sub>D</sub> = 1.0
<b>Straight Hanger</b>					
S/JCT (min)	1-10d	2-10d	4-#10	555	945
S/JCT (max)	1-10d	4-10d	6-#10	945	1465
S/HJCT (min)	2-10d	4-SDS 1/4 x 3 <sup>7</sup>	6-#14	1210	2625
S/HJCT (max)	2-10d	8-SDS 1/4 x 3 <sup>7</sup>	9-#14	1475	2980
<b>Skewed Hanger</b>					
S/JCT (min)	1-10d	2-10d	4-#10	390	845
S/JCT (max)	1-10d	4-10d	6-#10	775	1300
S/HJCT	2-10d	4-SDS 1/4 x 3 <sup>7</sup>	6-#14	1210	1935

For SI: 1 inch = 25.4 mm, 1 lb = 4.45 N.

1. Allowable loads for CFS members are based on a single 54 mil (16 ga) CFS member.
2. Allowable loads for wood headers are based on a minimum 4x12 DF-L wood member.
3. CFS / Steel Beam header must be braced to prevent web buckling per Designer specification.
4. CFS joist shall be laterally braced per Designer specification.
5. Self-tapping screws shall be installed from the hanger into the joist using joist hanger holes.
6. Backing in the steel beam cavity behind the hanger is not required to obtain tabulated loads.
7. SDS screws for use for designs in accordance with the 2006 IBC and IRC.



**S/JCT**

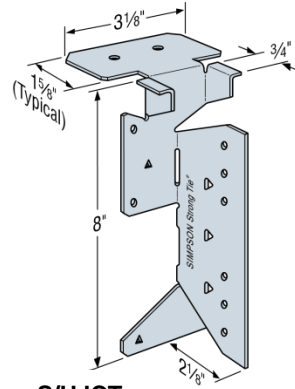

**S/HJCT**

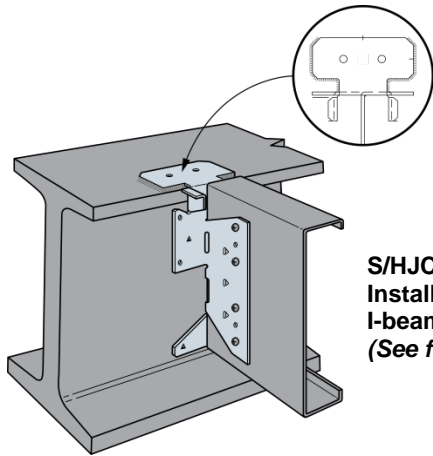

**S/HJCT Weld-on Installation to an I-beam Header (See footnote #6)**

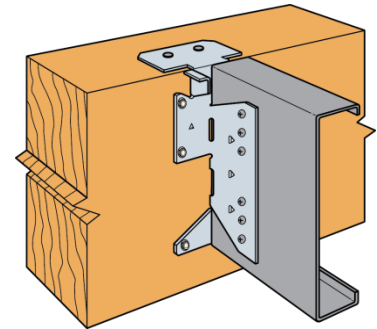

**S/HJCT Installation to a 4x10 Wood Header**

**S/HJCT Installation To a CFS Header**

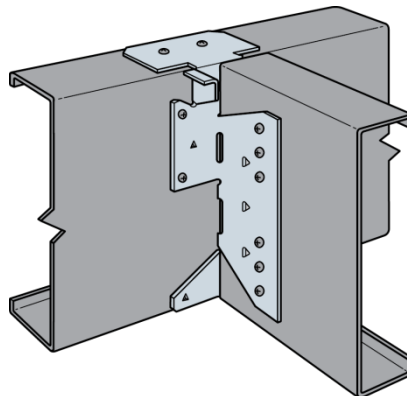

**FIGURE 6 - S/HJCT & S/JCT JOIST HANGERS**

**TABLE 7 – ALLOWABLE LOADS FOR TJC CONNECTOR**

Model No.	Fasteners		Allowable Load (lbs) 43 mil (18ga)		
	Carrying Member	Carried Member	0° (No Skew)	1°–60° Skew	61°–67.5° Skew
			TJC37 (Min)	4-#10	4-#10
TJC37 (Max)	6-#10	6-#10	680	630	530

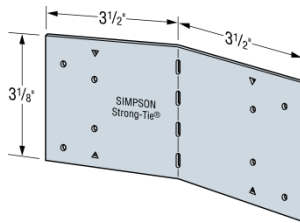

**TJC37**

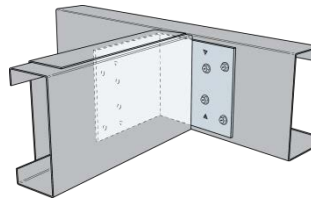

**Typical TJC37 Installation**

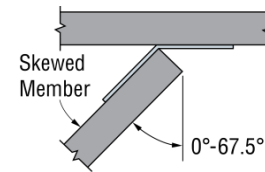

**Top View Installation**

**FIGURE 7 – TJC CONNECTOR**

**TABLE 8 – ALLOWABLE TENSION LOADS FOR TBD TRUSS BRACE DIAGONAL<sup>3,4,5,6,7</sup>**

Model No.	Fasteners <sup>2</sup>		Allowable Tension Loads (lbs) <sup>1</sup>	
	Strap Ends	Intermediate Trusses	Framing Member Thickness mil (ga)	
			27 mil (22 ga)	33 mil (20 ga)
TBD22	2 - #10	2 - #10	380	510

**For SI:** 1 inch = 25.4 mm, 1 lb = 4.45 N.

1. Load based on CFS trusses with a minimum yield strength,  $F_y$ , of 50 ksi and a minimum ultimate strength,  $F_u$ , of 65 ksi. Load shall be reduced proportionally for lower steel strength (actual strength / specified strength).
2. Screws shall be installed into the dimpled areas and placed to maintain a minimum of 1/4 inch strap edge distance and a minimum of 1/2 inch center to center end distance. A minimum of 5/8 inch (3D) edge distance is to be maintained for the truss members.
3. TBD22 straps are to be installed at approximate 45-degree angles.
4. Straps shall be installed tight.
5. To resist construction forces, diagonal x-bracing is required at each end and every 10 truss spaces (20 ft max). Reference SBCA CFSBCSI-08 for more information.
6. Trusses shall be laterally braced to resist out-of-plane forces at the end of the TBD22 diagonal braces.
7. TBD22 diagonal braces may be sheathed over.

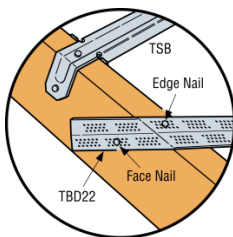

**Typical TBD22 Top Chord Installation**

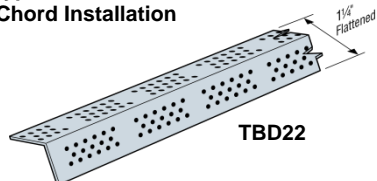

**TBD22**

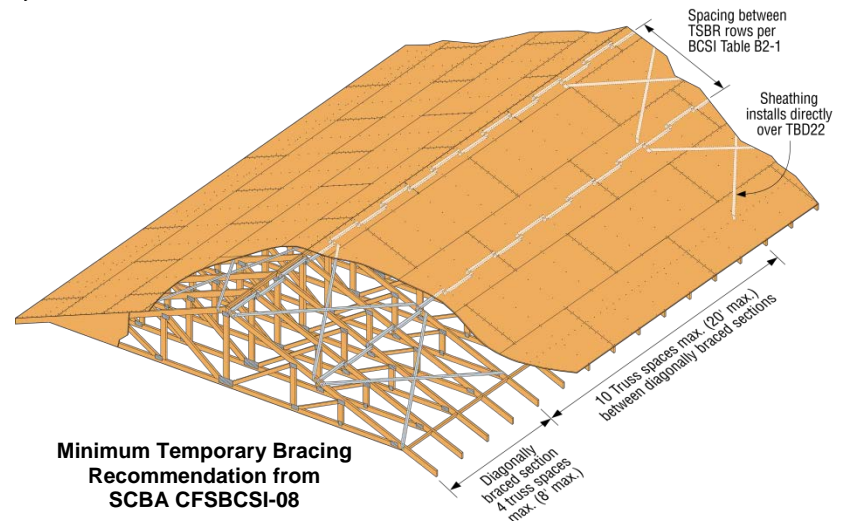

**Minimum Temporary Bracing Recommendation from SBCA CFSBCSI-08**

**FIGURE 8 – TBD TRUSS BRACE DIAGONAL**



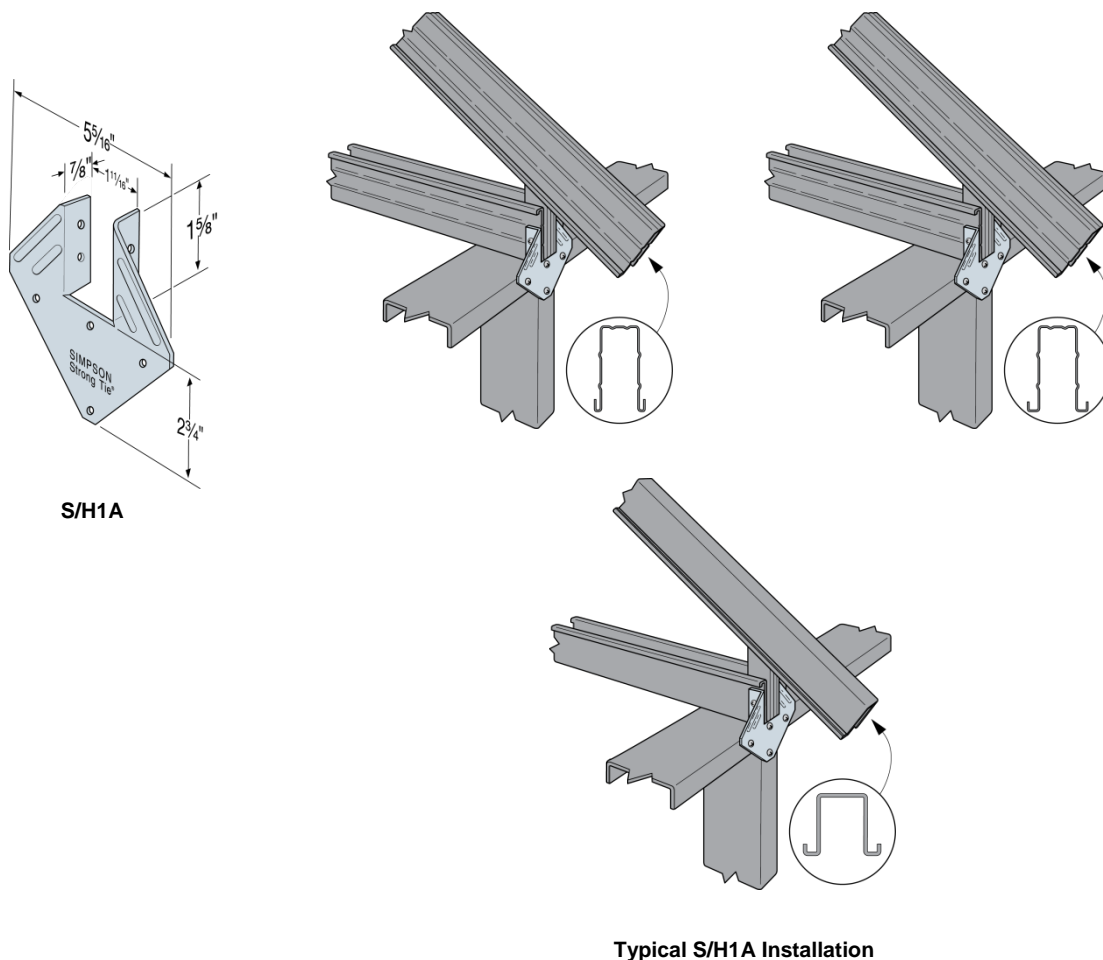

**TABLE 9 – ALLOWABLE LOADS FOR THE S/H1A HURRICANE TIE<sup>1</sup>**

Model No.	Fasteners <sup>3</sup>			Framing Member Thickness mil (ga)	Allowable Uplift Loads (lbs) <sup>2</sup>		
	Truss	Track	Stud		Track / Wall Stud Thickness		
					33 mil (20 ga)	43 mil (18 ga)	54 mil (16 ga)
S/H1A	4-#10	3-#10	1-#10	27 (22 ga)	470	470	470
	4-#10	3-#10	1-#10	33 (20 ga)	510	550	690
	4-#10	3-#10	1-#10	43 (18 ga)	510	550	690
	4-#10	3-#10	1-#10	54 (16 ga)	520	675	850

For SI: 1 inch = 25.4 mm, 1 lb = 4.45 N.

- S/H1A does not replace solid blocking.
- Load based on CFS trusses with a minimum yield strength,  $F_y$ , of 50 ksi and a minimum yield strength,  $F_u$ , of 65 ksi. Load shall be reduced proportionally for lower steel strength (actual strength / specified strength).  
For example: 43 mil (18 ga) thick CFS truss with  $F_y=33$  ksi and  $F_u=45$  ksi and connected to a 43 mil track and wall stud. The adjusted allowable load would be 550 lbs. x minimum  $[\frac{33}{50}$  or  $\frac{45}{65}] = 363$  lbs.
- Minimum 1 - #8 screw is required to attach top track to wall stud on the opposite side of S/H1A connector. This may be the typical track to stud screw connection.



**FIGURE 9 – S/H1A HURRICANE TIE**



**TABLE 10 – ALLOWABLE TENSION LOADS FOR STRAPS**

Model No.	Material Thick. mil (ga)	Dimensions (in)		Fasteners (Total) Framing Member Thickness			Allowable Tention Loads (lbs)			
		W	L	33 mil (20 ga)	43 mil (18 ga)	54 mil (16 ga)	33 mil (20 ga)	43 mil (18 ga)	54 mil (16 ga)	
LSTA9	33 (20 ga)	1 1/4	9	8- #10	8- #10	8- #10	705	1120	1190	
LSTA12		1 1/4	12	10- #10	10- #10	8- #10	885	1190	1190	
LSTA15		1 1/4	15	12- #10	12- #10	10- #10	1060	1190	1190	
LSTA18		1 1/4	18	14- #10	12- #10	10- #10	1190	1190	1190	
LSTA21		1 1/4	21	14- #10	12- #10	10- #10	1190	1190	1190	
LSTA24		1 1/4	24	14- #10	12- #10	10- #10	1190	1190	1190	
ST292		2 1/16	9 5/16	12- #10	10- #10	10- #10	1060	1240	1240	
ST2122		2 1/16	12 13/16	16- #10	12- #10	10- #10	1415	1500	1500	
ST2115		3/4	16 5/16	8- #10	6- #10	4- #10	630	630	630	
ST2215		2 1/16	16 5/16	20- #10	14- #10	10- #10	1765	1825	1825	
LSTA30		43 mil (18 ga)	1 1/4	30	18- #10	12- #10	10- #10	1555	1555	1555
LSTA36			1 1/4	36	18- #10	16- #10	14- #10	1555	1555	1555
LSTI49	3 3/4		49	32- #10	32- #10	20- #10	2830	4050	4050	
LSTI73	3 3/4		73	46- #10	32- #10	20- #10	4050	4050	4050	
MSTA9	1 1/4		9	8- #10	8- #10	8- #10	705	1050	1555	
MSTA12	1 1/4		12	10- #10	10- #10	8- #10	885	1315	1555	
MSTA15	1 1/4		15	12- #10	12- #10	10- #10	1060	1555	1555	
MSTA18	1 1/4		18	14- #10	12- #10	10- #10	1235	1555	1555	
MSTA21	1 1/4		21	16- #10	12- #10	10- #10	1415	1555	1555	
MSTA24	1 1/4		24	18- #10	12- #10	10- #10	1555	1555	1555	
MSTA30	1 1/4		30	22- #10	16- #10	12- #10	1945	1950	1950	
MSTA36	1 1/4		36	24- #10	18- #10	16- #10	1950	1950	1950	
ST6215	54 (16 ga)	2 1/16	16 15/16	20- #10	16- #10	10- #10	1765	2025	2025	
ST6224		2 1/16	23 5/16	28- #10	20- #10	12- #10	2455	2455	2455	
ST9		1 1/4	9	8- #10	8- #10	8- #10	705	1050	1350	
ST12		1 1/4	11 5/8	10- #10	10- #10	8- #10	885	1315	1350	
ST18		1 1/4	17 3/4	14- #10	12- #10	12- #10	1235	1350	1350	
ST22		1 1/4	21 5/8	20- #10	20- #10	20- #10	1350	1350	1350	
MSTC28		3	28 1/4	36- #10	36- #10	30- #10	3180	4600	4600	
MSTC40		3	40 1/4	52- #10	46- #10	46- #10	4595	4600	4600	
MSTC52		3	52 1/4	54- #10	42- #10	42- #10	4600	4600	4600	
MSTC66		68 (14 ga)	3	65 3/4	66- #10	46- #10	30- #10	5795	5795	5795
MSTC78			3	77 3/4	66- #10	46- #10	30- #10	5795	5795	5795
ST6236			2 1/16	33 13/16	40- #10	30- #10	18- #10	3535	3760	3760
HRS6	97 (12 ga)	1 3/8	6	6- #10	6- #10	6- #10	530	790	1600	
HRS8		1 3/8	8	10- #10	10- #10	10- #10	885	1315	2670	
HRS12		1 3/8	12	14- #10	14- #10	12- #10	1235	1840	2710	
FHA6		1 7/16	6 3/8	8- #10	8- #10	8- #10	705	1050	2045	
FHA9		1 7/16	9	8- #10	8- #10	8- #10	705	1050	2045	
FHA12		1 7/16	11 5/8	8- #10	8- #10	8- #10	705	1050	2045	
FHA18		1 7/16	17 3/4	8- #10	8- #10	8- #10	705	1050	2045	
FHA24		1 7/16	23 7/8	8- #10	8- #10	8- #10	705	1050	2045	
FHA30		1 7/16	30	8- #10	8- #10	8- #10	705	1050	2045	
MSTI26		2 1/16	26	26- #10	26- #10	22- #10	2300	3420	5025	
MSTI36		2 1/16	36	36- #10	36- #10	22- #10	3180	4735	5025	
MSTI48		2 1/16	48	48- #10	40- #10	22- #10	4240	5025	5025	
MSTI60	118 (10 ga)	2 1/16	60	58- #10	40- #10	22- #10	5025	5025	5025	
MSTI72		2 1/16	72	62- #10	58- #10	54- #10	5025	5025	5025	
S/MST27		2 1/16	27	30- #10	30- #10	22- #10	2650	3945	5025	
S/MST37		2 1/16	37 1/2	42- #10	40- #10	22- #10	3710	5025	5025	
S/MST48		2 1/16	48	54- #10	40- #10	24- #10	4770	5155	5155	
S/MST60		2 1/16	60	68- #10	52- #10	30- #10	6010	6650	6650	
S/MST72		2 1/16	72	76- #10	52- #10	30- #10	6650	6650	6650	

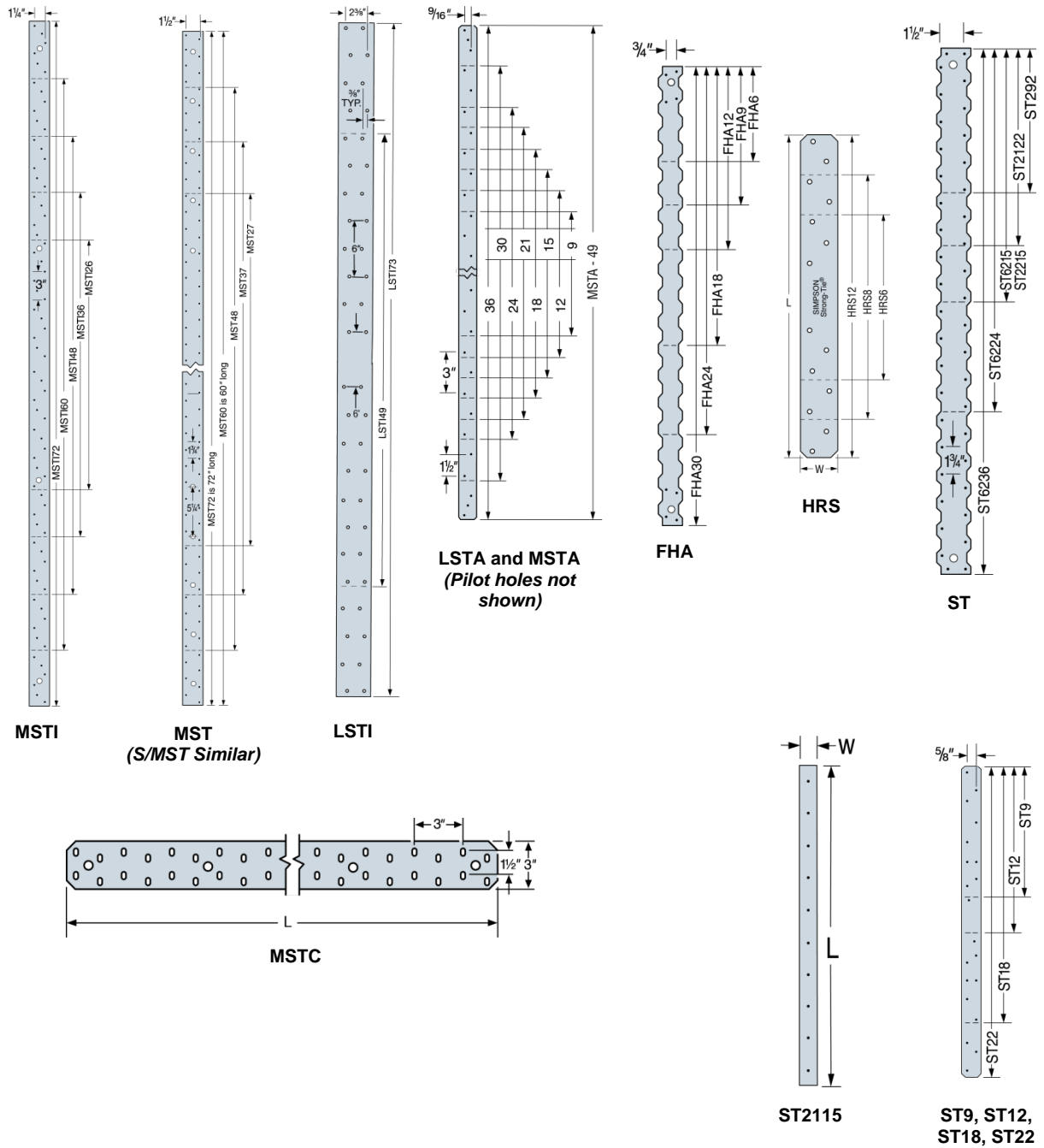

FIGURE 10 - STRAPS

**TABLE 11 – ALLOWABLE TENSION LOADS FOR COILED STRAPS**

Model No.	Total Length (ft) <sup>5</sup>	Material Thickness mil (ga)	Fasteners (Total) Framing Member Thickness <sup>1</sup>			Allowable Tension Loads (lbs) <sup>6,7</sup>
			33 mil (20 ga)	43 mil (18 ga)	54 mil (16 ga)	
CMST12	40 <sup>2</sup>	97 (12 ga)	104-#10	70-#10	40-#10	9080
CMST14	52 ½ <sup>2</sup>	68 (14 ga)	72-#10	50-#10	28-#10	6365
CMSTC16	54 <sup>3</sup>	54 (16 ga)	54-#10	36-#10	30-#10	4600
CS14	100 <sup>4</sup>	68 (14 ga)	28-#10	18-#10	12-#10	2305
CS16	150 <sup>4</sup>	54 (16 ga)	18-#10	12-#10	8-#10	1550
CS18	200 <sup>4</sup>	43 (18 ga)	14-#10	10-#10	6-#10	1235
CS20	250 <sup>4</sup>	33 (20 ga)	12-#10	8-#10	6-#10	945
CS22	300 <sup>4</sup>	27 (22 ga)	10-#10	6-#10	6-#10	775

For SI: 1 inch = 25.4 mm, 1 lb = 4.45 N.

- One-half of the fasteners shall be installed in each member being connected to achieve the listed loads.
- For CMST straps: Minimum End Length (inches) = 1/2 total fasteners x 7/8 inch + 1 inch when all holes filled. Double length if only round holes filled.
- For CMSTC16 straps: Minimum End Length (inches) = 1/2 total fasteners x ¾ inch + 1 inch when all holes filled. Double length if only round holes filled.
- For CS straps: Minimum End Length (inches) = 1/2 total fasteners + 1 inch.
- Total Cut Length = End Length + Clear Span + End Length.
- Where a reduced number of self-tapping screws are installed, allowable load = (#screws used / #screws in table) x table load.
- Loads are based on lesser of steel strap capacity and fastener calculations in accordance with AISI S100.

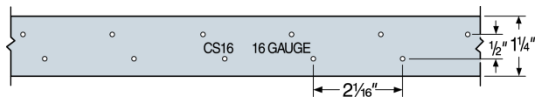

**CS Hole Pattern**  
(all other CS straps similar)

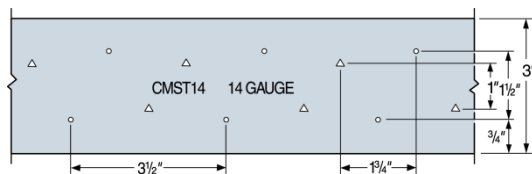

**CSMST14 Hole Pattern**  
(CMST12 similar)

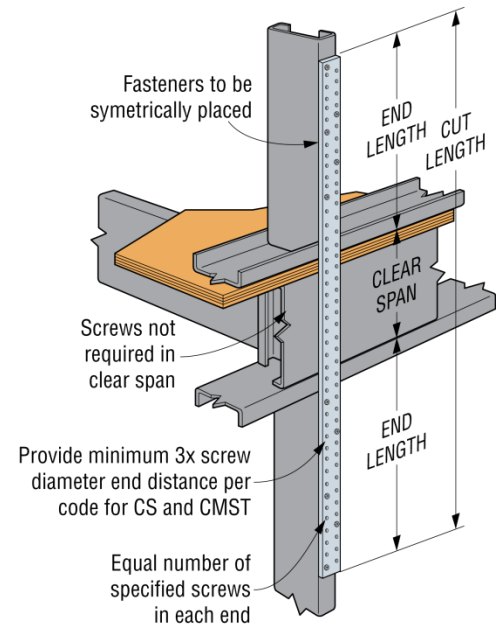

**Typical CS Installation**  
As a Floor-to-Floor Tie

**FIGURE 11 – COILED STRAPS**



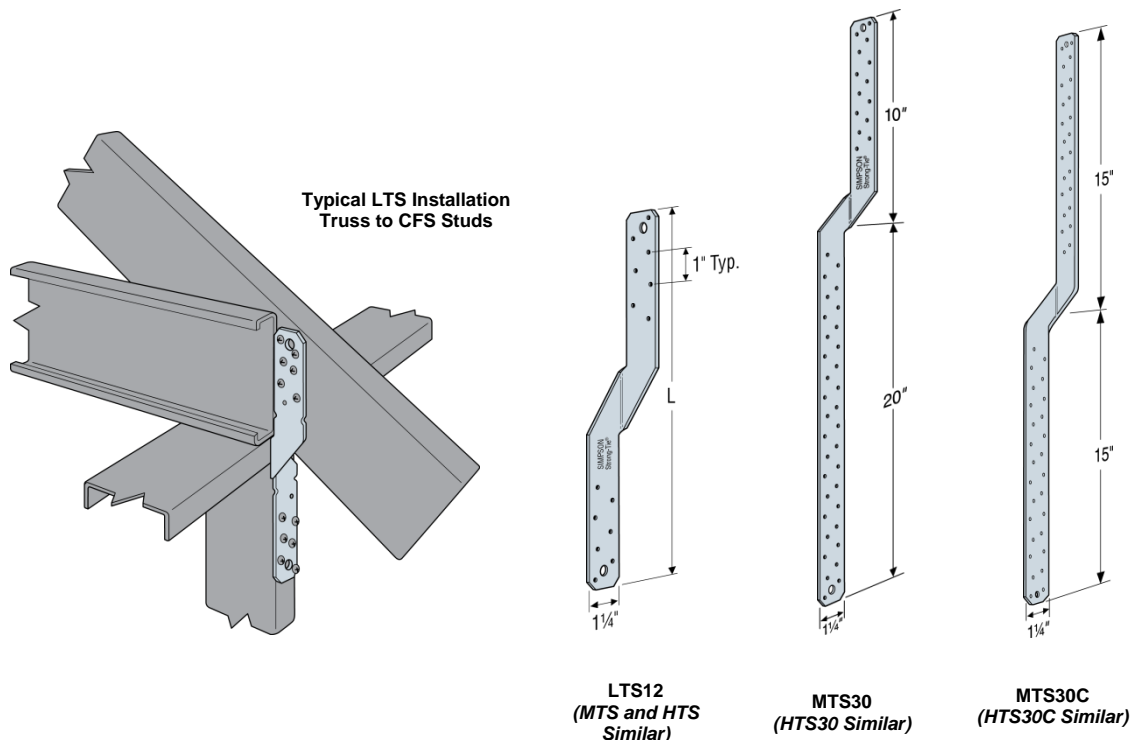

**TABLE 12 – ALLOWABLE TENSION LOADS FOR TWIST STRAPS**

Model No. <sup>3,5</sup>	Material Thickness mil (ga.)	L (in.)	Fasteners (Total) <sup>1,2</sup> Framing Member Thickness			Allowable Tension Loads <sup>4,6</sup> , (lbs)		
			33 mil (20 ga)	43 mil (18 ga)	54 mil (16 ga)	33 mil (20 ga)	43 mil (18 ga)	54 mil (16 ga)
LTS12	43 (18 ga)	12	10-#10	6-#10	6-#10	775	775	775
LTS16		16						
LTS18		18						
LTS20		20						
MTS12	54 (16 ga)	12	12-#10	8-#10	6-#10	995	995	995
MTS16		16						
MTS18		18						
MTS20		20						
MTS30		30						
MTS24C		24						
MTSC30		30						
HTS16	68 (14 ga)	16	18-#10	12-#10	6-#10	1415	1450	1450
HTS20		20						
HTS24		24						
HTS28		28						
HTS30		30						
HTS30C		30						

For SI: 1 inch = 25.4 mm, 1 lb = 4.45 N.

1. Not all fastener holes need to be filled as additional fastener holes are provided.
2. Install half of the listed fasteners in each end of the strap to achieve full loads.
3. All straps except the MTS30 and HTS30 have the twist in the center of the strap.
4. Twist straps do not have to be wrapped over the truss to achieve the listed load.
5. May be installed on the inside face of the stud.
6. Loads are based on minimum steel thickness listed.



**FIGURE 12 – TWIST STRAPS**



### TABLE 13 – ALLOWABLE LOADS FOR SP SERIES STUD PLATE (TRACK) TIES

Model No.	Dimensions (in)		Fasteners	Allowable Uplift Loads (lbs)
	W	L		
SP4	3 9/16	7 1/4	6 - #10	825
SP6	5 9/16	7 3/4	6 - #10	825

For SI: 1 inch = 25.4 mm, 1 lb = 4.45 N.

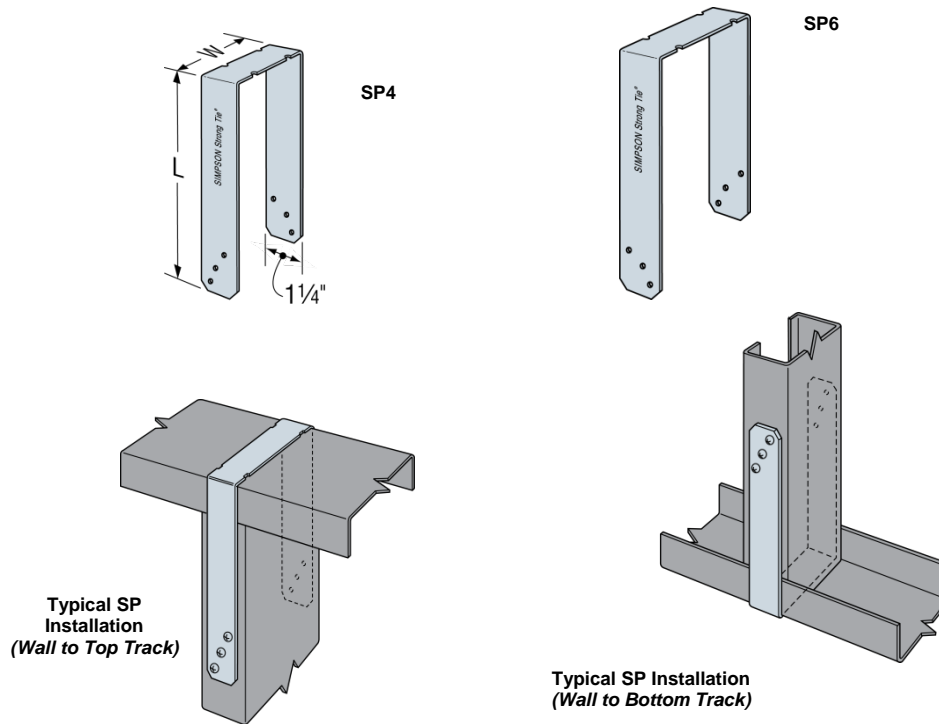

### FIGURE 13 – SP STUD PLATE (TRACK) TIE

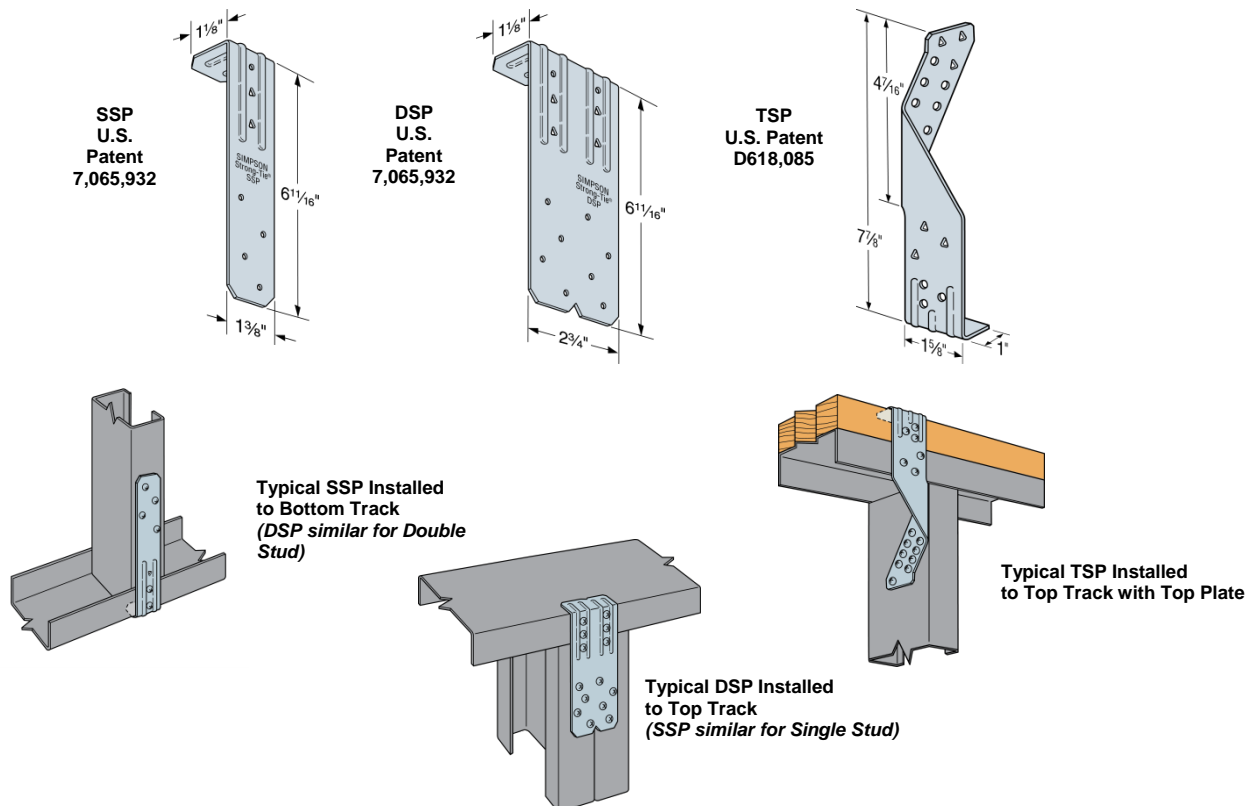

**TABLE 14 – ALLOWABLE LOADS FOR SSP, DSP & TSP STUD PLATE (TRACK) TIES**

Model No.	Fasteners				Allowable Uplift Loads (lbs)	
	Studs	Top Track		Bottom Track	33 mil (20 ga)	43 mil (18 ga)
		CFS	Wood <sup>1,2,3</sup>			
SSP	4 - #10	—	—	2 - #10	355	625
		—	2 - #10	—	340	600
		2 - #10	1 - #10	—	405	715
		2 - 10d	1 - #10	—	480	840
DSP	8 - #10	—	—	4 - #10	430	695
		—	4 - #10	—	475	775
		4 - #10	2 - #10	—	585	955
		4 - 10d	2 - #10	—	730	1200
TSP	6 - #10	—	—	3 - #10	345	645
		—	3 - #10	—	370	700
	9 - #10	3 - #10	3 - #10	—	360	685
		3 - 10d	3 - #10	—	480	905

For SI: 1 inch = 25.4 mm, 1 lb = 4.45 N.

1. For wood plates, noted values only apply to DF/SP members where wood top plates are used. For SPF values, multiply by 0.86.
2. For wood plates, when cross-grain tension cannot be avoided, mechanical reinforcement to resist such forces should be considered.
3. Self-tapping screws installed into wood plates with a minimum #10x ¾ inch.



**FIGURE 14 – SSP, DSP & TSP STUD PLATE (TRACK) TIE**

**TABLE 15 – ALLOWABLE LOADS FOR LTP5 LATERAL TIE PLATE**

Model No.	Type of Connection <sup>2</sup>	Direction of Load	Fasteners		Allowable Loads (lbs) <sup>1,3,4</sup>
			To Rim Joist	To Tracks & Shear Wall	43 mil (18 ga)
LTP5	1	G	7-#10	7-#10	1045
	2		7-#10	7-#10	1110
	3		7 – 8d x 1 1/2	7-#10	730 <sup>4</sup>

For SI: 1 inch = 25.4 mm, 1 lb = 4.45 N.

1. Allowable loads are for one connector.
2. When anchors are installed on each side of joist, the minimum joist thickness is 3 inches.
3. Allowable loads are based on CFS (stud & sheet) of 43 mil (18 ga) minimum.
4. Allowable load for Connection 3 assumes duration increase (C<sub>D</sub>) = 1.60.

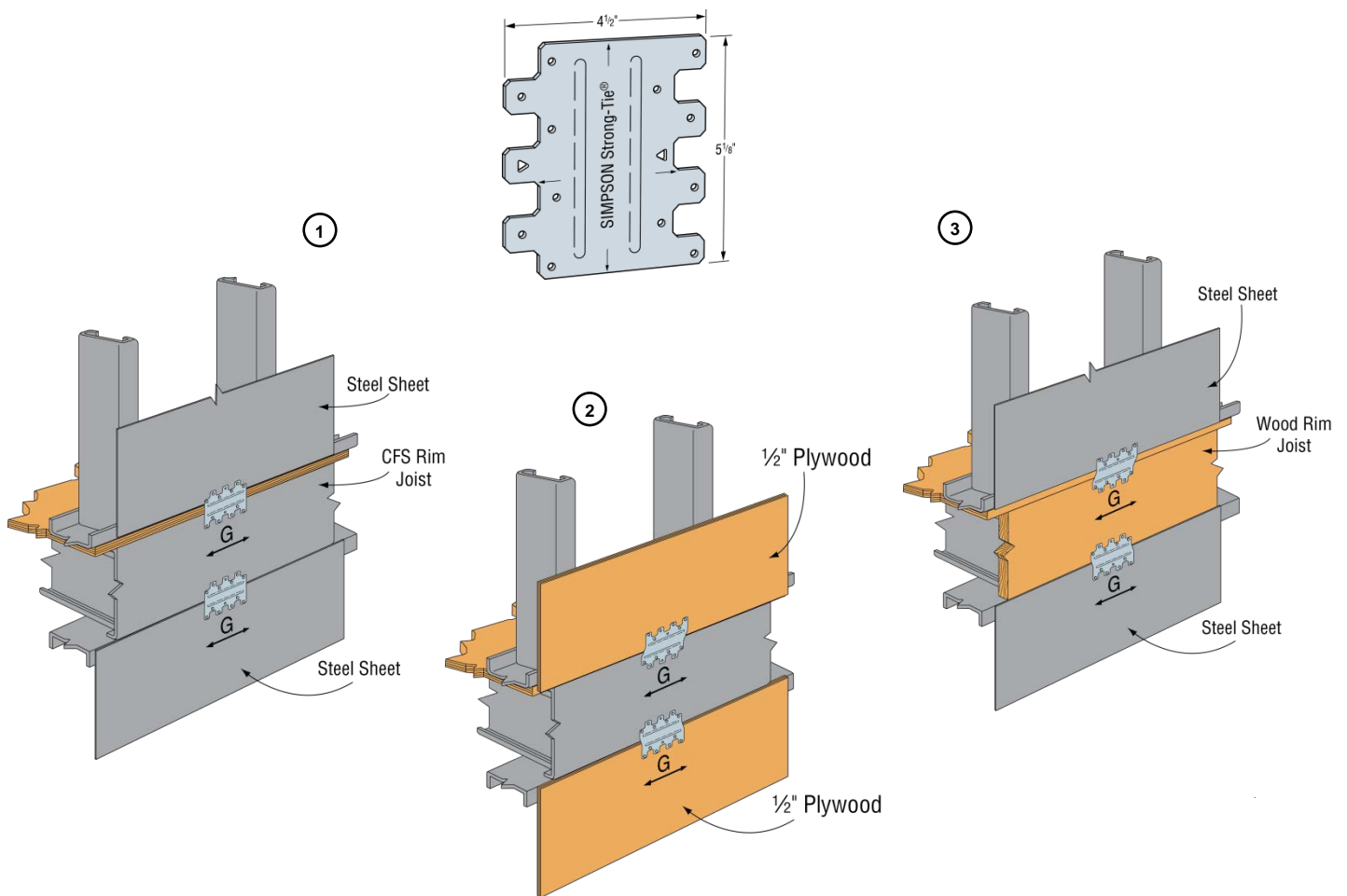

**FIGURE 15 – LTP5 LATERAL TIE PLATE**





TABLE 16 – ALLOWABLE LOADS FOR STC & DTC TRUSS CLIP

Model No.	Fasteners		Allowable Loads (lbs)					
	Base	Slot <sup>3</sup>	Without Gap <sup>1</sup>		With 1/4" Gap		With 1/2" Gap	
			F <sub>1</sub> <sup>2</sup>	F <sub>2</sub>	F <sub>1</sub> <sup>2</sup>	F <sub>2</sub>	F <sub>1</sub> <sup>2</sup>	F <sub>2</sub>
STC	2-#8	1-#8	185	35	135	35	75	35
DTC	4-#8	2-#8	200	160	200	160	145	160

For SI: 1 inch = 25.4 mm, 1 lb = 4.45 N.

1. Truss or rafter must be bearing on top plate to achieve the allowable loads under "WITHOUT GAP."
2. Clips are required on both sides of the truss to achieve F<sub>1</sub> loads in both directions (*stagger parts to avoid screw interference*).
3. Slot screw(s) are to be installed in the middle of the slot.

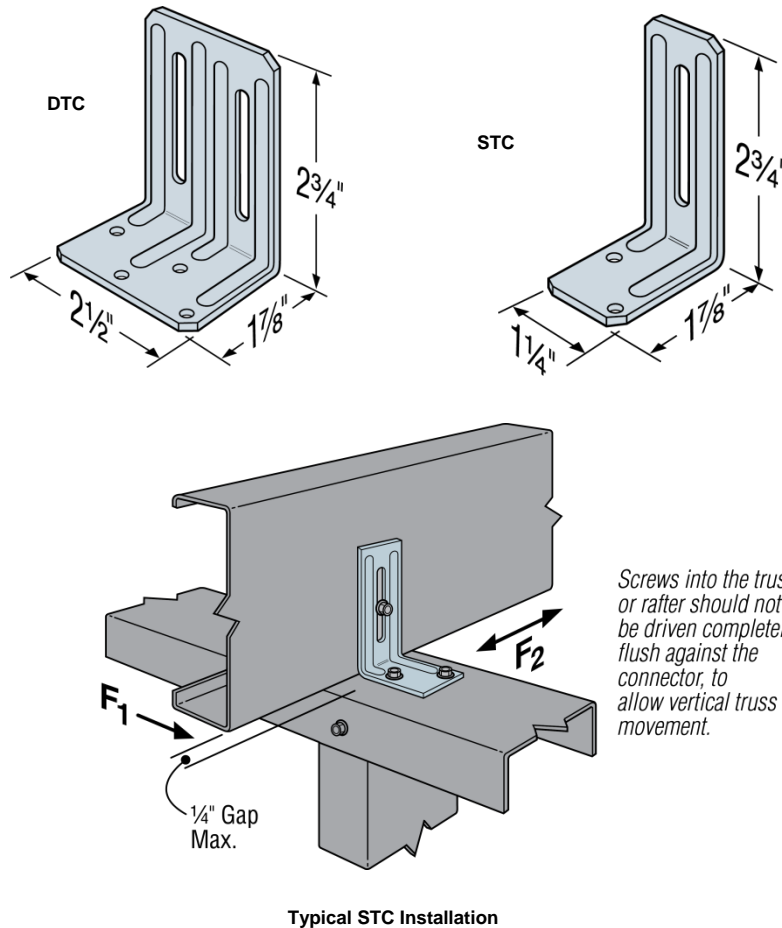

FIGURE 16 – STC AND DTC TRUSS CLIPS

**TABLE 17 – ALLOWABLE TORSIONAL MOMENT, BRACE STRENGTH AND BRACE STIFFNESS FOR LSUBH, SUBH AND MSUBH SERIES CONNECTORS**

Model No.	Stud Depth (in.)	Stud Thickness mils (ga.)	Laterally Loaded C-Stud <sup>1</sup>		Axially Loaded C-Stud <sup>1</sup>			
			Allowable Torsional Moment <sup>2</sup> (in. - lbs)		Allowable Brace Strength <sup>2</sup> (lbs.)		Brace Stiffness <sup>3</sup> (lbs./in.)	
			Min	Max	Min	Max	Min	Max
LSUBH3.25	3.625	33 (20)	215	330	155	275	2300	2685
		43 (18)	230	370	175	310	5075	7585
		54 (16)	225	370	195	345	5075	8100
SUBH3.25	3.625	20 (33)	320	345	230	370	1450	1985
		18 (43)	355	430	255	420	2780	4035
		16 (54)	420	455	290	475	2925	3975
MSUBH3.25	3.625	16 (54)	550	800	435	630	3440	4015
		14 (68)	640	860	485	695	4040	6145
		12 (97)	670	860	515	770	6860	14265
LSUBH3.25	6.00	33 (20)	225	330	120	140	870	730
		43 (18)	250	395	155	285	1010	2075
		54 (16)	265	395	180	330	1025	2565
SUBH3.25	6.00	20 (33)	275	385	110	110	605	605
		18 (43)	295	525	230	250	1050	1205
		16 (54)	350	550	275	415	1130	1700
MSUBH3.25	6.00	16 (54)	565	895	385	430	1630	1695
		14 (68)	655	925	455	620	1860	2655
		12 (97)	690	960	505	765	4070	4090
LSUBH3.25	8.00	43 (18)	235	375	135	135	815	815
		54 (16)	250	375	180	260	1130	1130
SUBH3.25	8.00	18 (43)	255	570	190	190	505	535
		16 (54)	325	605	250	300	895	1025
MSUBH3.25	8.00	17 (54)	545	890	270	270	1025	1045
		14 (68)	635	925	435	455	1400	1400
		12 (97)	665	955	545	545	2465	2465

For SI: 1 inch = 25.4 mm, 1lb = 4.45N.

- To obtain allowable loads tabulated for "Min." fasteners, a screw shall be placed in each pre-punch round hole (1 screw total). For allowable loads tabulated for "Max." fastener, a screw shall be placed in each of the pre-punch round and triangle holes (2 screws total).
- Allowable loads are for use when utilizing the Allowable Stress Design (ASD) methodology. For LRFD loads the ASD tabulated values shall be multiplied by 1.6.
- Tabulated values apply to both ASD and LRFD designs.

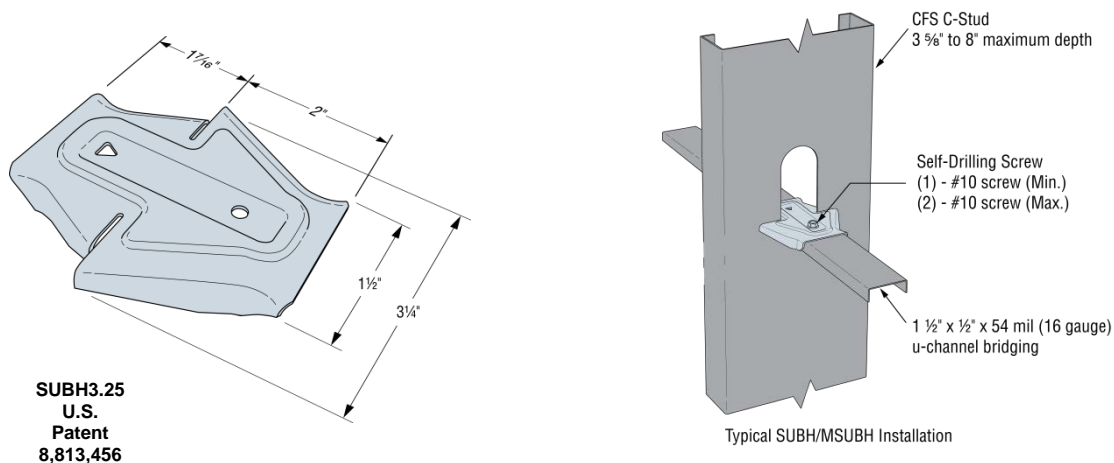

**FIGURE 17 – LSUBH/SUBH MSUBH CONNECTORS**



**TABLE 18--CONNECTOR MATERIAL PROPERTIES TABLE**

Model No. / Model Series	ASTM Specification	Minimum Yield Strength F <sub>y</sub> (ksi)	Minimum Tensile Strength F <sub>u</sub> (ksi)	Nominal Thickness	Min. Base Metal Thickness (inch)
S/HDB (Base Plate)	A36	33	52	½ inch	0.485
S/HD8B & 10B (Body)	A 1011 Grade 40	40	55	10 GA.	0.126
S/HD15B (Body)	A 1011 Grade 40	40	55	7 GA.	0.171
S/HDS (Base Plate)	A36	33	52	½ inch	0.485
S/HD8S & 10S (Body)	A 1011 Grade 40	40	55	10 GA.	0.126
S/HD15S (Body)	A 1011 Grade 40	40	55	7 GA.	0.171
S/HDU (Washer)	A 1011 Grade 33	33	52	3 GA.	0.229
S/HDU (Body)	A 653 SS GR 33	33	45	10 GA.	0.129
S/LTT (Body)	A 653 SS GR 33	33	45	12 GA.	0.099
S/LTT (Base)	A 1011 Grade 33	33	52	3 GA.	0.229
S/DTT2Z	A 653 SS GR 33	33	45	14 GA.	0.070
S/HTT, HTT	A 653 SS GR 33	33	45	11 GA.	0.112
S/BA	A 653 SS GR 33	33	45	14 GA.	0.070
S/B	A 653 SS GR 33	33	45	12 GA.	0.099
S/LBV	A 653 SS GR 33	33	45	14 GA.	0.070
S/HJCT	A 653 SS GR 40	42	56	12 GA.	0.099
S/JCT	A 653 SS GR 40	40	55	14 GA.	0.070
TJC37	A 653 SS GR 33	33	45	16 GA.	0.057
TBD22	A 653 SS GR 40	40	55	22 GA.	0.029
S/H1A	A 653 SS GR 33	33	45	18 GA.	0.046
LSTA12, 15, 18, 21, 24	A 653 SS GR 50 CL1	50	65	20 GA.	0.035
LSTA30 & LSTA36	A 653 SS GR 50 CL1	50	65	18 GA.	0.046
MSTA9, 12, 15, 18, 21, 24,	A 653 SS GR 50 CL1	50	65	18 GA.	0.046
MSTA30, 36, 49	A 653 SS GR 50 CL1	50	65	16 GA.	0.057
MSTC28, 40, 52	A 653 SS GR 50 CL1	50	65	16 GA.	0.057
S/MST27, 37	A 653 SS GR 40	40	55	12 GA.	0.099
S/MST48	A 653 SS GR 40	42	56	12 GA.	0.099
S/MST60, 72	A 653 SS GR 40	42	56	10 GA.	0.129
LSTI	A 653 SS GR 40	40	55	18 GA.	0.046
MSTI	A 653 SS GR 40	40	55	12 GA.	0.099
ST9, ST12, ST18, ST22	A 653 SS GR 33	33	45	16 GA.	0.057
ST6215	A 653 SS GR 33	33	45	16 GA.	0.057
ST6224	A 653 SS GR 40	40	55	16 GA.	0.057
ST2115	A 653 SS GR 50 CL1	50	65	20 GA.	0.035
ST2122	A 653 SS GR 40	40	55	20 GA.	0.035
ST2215	A 653 SS GR 50 CL1	50	65	20 GA.	0.035
ST292	A 653 SS GR 33	33	45	20 GA.	0.035
ST6236	A 653 SS GR 50 CL1	50	65	14 GA.	0.070
FHA	A 653 SS GR 33	33	45	12 GA.	0.099
HRS	A 653 SS GR 33	33	45	12 GA.	0.099
CMST12	A 653 SS GR 50 CL1	50	65	12 GA.	0.099
CMST14	A 653 SS GR 50 CL1	50	65	14 GA.	0.070



**TABLE 18- CONNECTOR MATERIAL PROPERTIES TABLE (CONT.)**

CMSTC16	A 653 SS GR 50 CL1	50	65	16 GA.	0.057
CS14	A 653 SS GR 50 CL1	50	65	14 GA.	0.070
CS16	A 653 SS GR 40	40	55	16 GA.	0.057
CS18	A 653 SS GR 40	40	55	18 GA.	0.046
CS20	A 653 SS GR 40	40	55	20 GA.	0.035
CS22	A 653 SS GR 40	40	55	22 GA.	0.029
LTS	A 653 SS GR 33	33	45	18 GA.	0.046
MTS, MTSC	A 653 SS GR 33	33	45	16 GA.	0.057
HTS, HTSC	A 653 SS GR 40	40	55	14 GA.	0.070
SP	A 653 SS GR 33	33	45	20 GA.	0.035
SSP	A 653SS GR 40	40	55	18 GA.	0.046
DSP	A 653SS GR 40	40	55	18 GA.	0.046
TSP	A 653SS GR 40	40	55	16 GA.	0.057
LTP5	A 653SS GR 40	40	55	20 GA.	0.035
DTC	A 653 SS GR 33	33	45	18 GA.	0.046
STC	A 653 SS GR 33	33	45	18 GA.	0.046
LSUBH	A 653SS GR 40	40	55	20 GA.	0.035
SUBH	A 653 SS GR 40	40	55	18 GA.	0.046
MSUBH	A 653 SS GR 40	40	55	14 GA.	0.070

For SI: 1 inch = 25.4 mm, 1 psi = 6.895 kPa.