



DEPARTMENT OF REGULATORY AND ECONOMIC RESOURCES (RER)
BOARD AND CODE ADMINISTRATION DIVISION

MIAMI-DADE COUNTY
PRODUCT CONTROL SECTION
11805 SW 26 Street, Room 208
Miami, Florida 33175-2474
T (786) 315-2590 F (786) 315-2599
www.miamidade.gov/economy

NOTICE OF ACCEPTANCE (NOA)

O'Hagin Manufacturing, LLC
210 Classic Court, Suite #100
Rohnert Park, CA 94928

SCOPE:

This NOA is being issued under the applicable rules and regulations governing the use of construction materials. The documentation submitted has been reviewed and accepted by Miami-Dade County RER - Product Control Section to be used in Miami Dade County and other areas where allowed by the Authority Having Jurisdiction (AHJ).

This NOA shall not be valid after the expiration date stated below. The Miami-Dade County Product Control Section (In Miami Dade County) and/or the AHJ (in areas other than Miami Dade County) reserve the right to have this product or material tested for quality assurance purposes. If this product or material fails to perform in the accepted manner, the manufacturer will incur the expense of such testing and the AHJ may immediately revoke, modify, or suspend the use of such product or material within their jurisdiction. RER reserves the right to revoke this acceptance, if it is determined by Miami-Dade County Product Control Section that this product or material fails to meet the requirements of the applicable building code.

This product is approved as described herein, and has been designed to comply with the Florida Building Code including the High Velocity Hurricane Zone of the Florida Building Code.

DESCRIPTION: Fire & Ice® / WeatherMaster™ Flame and Ember Resistant Compo 72” Shingle Vent with High Wind Diverter

LABELING: Each unit shall bear a permanent label with the manufacturer's name or logo, city, state and following statement: "Miami-Dade County Product Control Approved", unless otherwise noted herein.

RENEWAL of this NOA shall be considered after a renewal application has been filed and there has been no change in the applicable building code negatively affecting the performance of this product.

TERMINATION of this NOA will occur after the expiration date or if there has been a revision or change in the materials, use, and/or manufacture of the product or process. Misuse of this NOA as an endorsement of any product, for sales, advertising or any other purposes shall automatically terminate this NOA. Failure to comply with any section of this NOA shall be cause for termination and removal of NOA.

ADVERTISEMENT: The NOA number preceded by the words Miami-Dade County, Florida, and followed by the expiration date may be displayed in advertising literature. If any portion of the NOA is displayed, then it shall be done in its entirety.

INSPECTION: A copy of this entire NOA shall be provided to the user by the manufacturer or its distributors and shall be available for inspection at the job site at the request of the Building Official.

This renews NOA 12-1113.19 and consists of pages 1 through 6.
The submitted documentation was reviewed by Juan E. Collao, R.A.



Juan E. Collao

NOA No 14-0731.02
Expiration Date: 12/09/19
Approval Date: 10/30/14
Page 1 of 6

ROOFING ASSEMBLY APPROVAL

Category: Roofing
Sub-Category: Static Roof Vent
Materials: 26 ga. G90 Steel; .032” Aluminum; 16 oz. Copper
Minimum Slope: 2:12

TRADE NAMES OF PRODUCTS MANUFACTURED OR LABELED BY APPLICANT

<u>Product</u>	<u>Dimensions</u>	<u>Test Specification</u>	<u>Product Description</u>
Fire & Ice® / WeatherMaster™ Flame and Ember Resistant Compo 72” Shingle Vent with High Wind Diverter	Length: 32” Width: 25” Height: 2 3/8”	TAS 100(A)	Metal off ridge roof vent with high wind diverter, and a galvanized or stainless steel wire mesh, for installation on asphalt shingle roof systems.
Fire & Ice® / WeatherMaster™ Flame and Ember Resistant Compo 72” Shingle Vent with High Wind Diverter and Extended Flange	Length: 36” Width: 30” Height: 2 3/8”	TAS 100(A)	Metal off ridge roof vent with high wind diverter, and a galvanized or stainless steel wire mesh, for installation on asphalt shingle roof systems.
High Wind Diverter	Length: 24” Width: 2” Height: 2”	TAS 100(A)	Metal high wind diverter for installation with metal off ridge vent.

MANUFACTURING LOCATIONS

1. Lakeland, FL.
2. Rohnert Park, CA

EVIDENCE SUBMITTED

<u>Test Agency/Identifier</u>	<u>Name</u>	<u>Report</u>	<u>Date</u>
PRI Construction Materials Technologies	TAS 100(A) Amendment Letter	OHI-032-02-02 OHI-032-02-02	08/04/09 04/03/12



NOA No 14-0731.02
 Expiration Date: 12/09/19
 Approval Date: 10/30/14
 Page 2 of 6

APPROVED APPLICATIONS

- Trade Name:** Fire & Ice[®] / WeatherMaster[™] Flame and Ember Resistant Compo 72" Shingle Vent with High Wind Diverter
- System Type A:** Mechanical attachment of vent under asphalt shingles
- Slot:** Starting approximately 18" down the ridge and a minimum 12" from the edges, mark an 11" x 11" opening centered between layout lines and aligned approximately as shown on exposure lines as seen in Detail B. Set blade to thickness of sheathing and cut opening. Brush away sawdust and debris.
- Installation:** Place a bead of approved mastic underneath the vent flange. Place the primary vent over the roof deck opening. Install high wind diverter in front of and 2" below the primary vent. Place a bead of approved sealant to underside of diverter. Refer to Detail B.
- Fasten the vent and diverter with 12 ga., 1 1/4" corrosion resistant galvanized ring shank roofing nails spaced 4" o.c. Nails shall be of sufficient length to penetrate through the sheathing a minimum of 3/16". Refer to Detail B.
- Installation of shingles around high wind diverter shall be on mark so that next shingle course can be installed over base of diverter, leaving 1/4" to 1/2" channel between edge of shingle course above diverter and inside diverter wall. Install shingles around and above vent flange after completing the vent installation. Shingles shall be installed in accordance to the shingle's approved Notice of Acceptance.
- Ventilation Calculations:** See manufacturer's published literature for net free area.

GENERAL LIMITATIONS:

1. Refer to applicable building code for required ventilation.
2. The installation shall be applied in compliance with the manufacturer's current published application instruction and the requirements set forth in the applicable building code.
3. O'Hagin's Fire & Ice[®] / WeatherMaster[™] Flame and Ember Resistant Compo 72" Shingle Vent with High Wind Diverter is approved to be installed with asphalt shingles only.
4. O'Hagin's Fire & Ice[®] / WeatherMaster[™] Flame and Ember Resistant Compo 72" Shingle Vent with High Wind Diverter shall not be installed on roof mean heights greater than 33 ft.
5. All products listed herein shall have a quality assurance audit in accordance with the Florida Building Code and Rule 61G20-3 of the Florida Administrative Code.
6. All approved products listed herein shall be labeled and shall bear the imprint or identifiable marking of the manufacturer's name or logo, city and state of manufacturing facility, and following statement: "Miami-Dade County Product Control Approved" or the Miami-Dade County Product Control Seal as shown below.

MIAMI-DADE COUNTY
APPROVED

MIAMI-DADE COUNTY
APPROVED

NOA No 14-0731.02
Expiration Date: 12/09/19
Approval Date: 10/30/14
Page 3 of 6

DETAIL "A"

FIRE & ICE[®] / WEATHERMASTER[™] FLAME AND EMBER RESISTANT COMPO 72" SHINGLE VENT WITH HIGH WIND DIVERTER

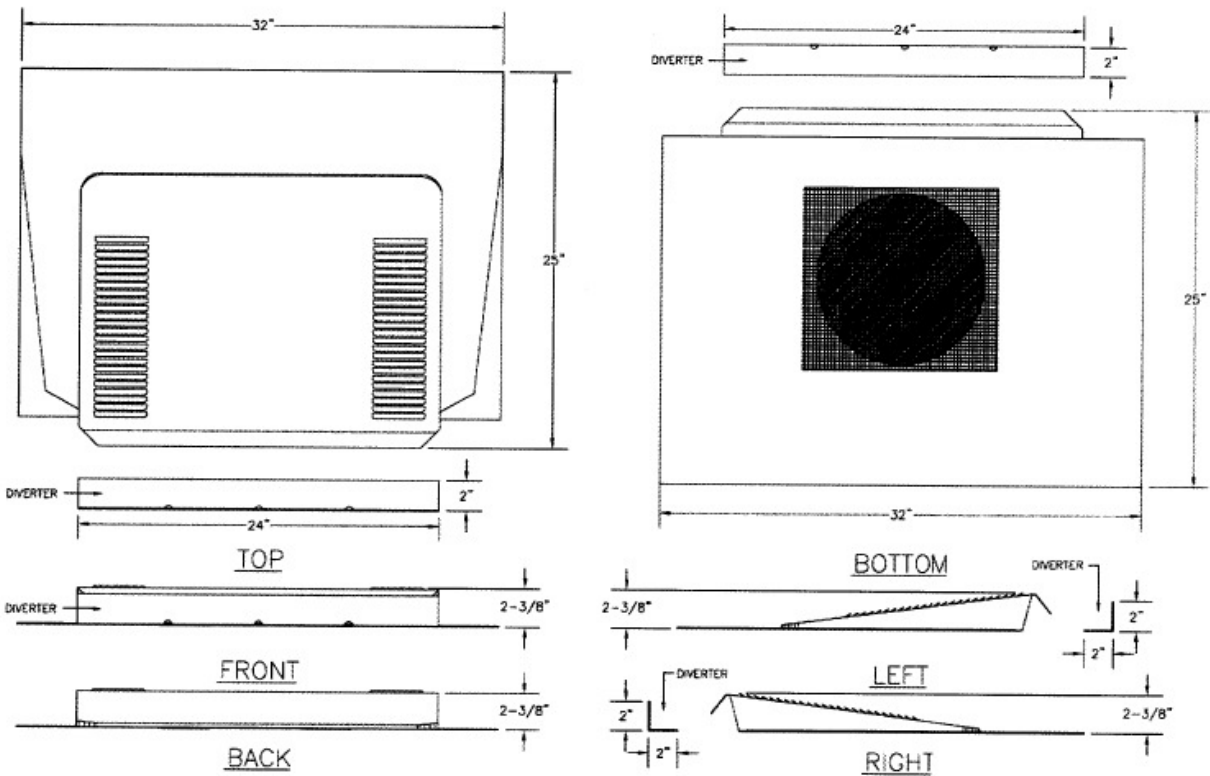

DETAIL "A" (CONTINUED)

FIRE & ICE® / WEATHERMASTER™ FLAME AND EMBER RESISTANT COMPO 72" SHINGLE VENT WITH HIGH WIND DIVERTER AND EXTENDED FLANGE

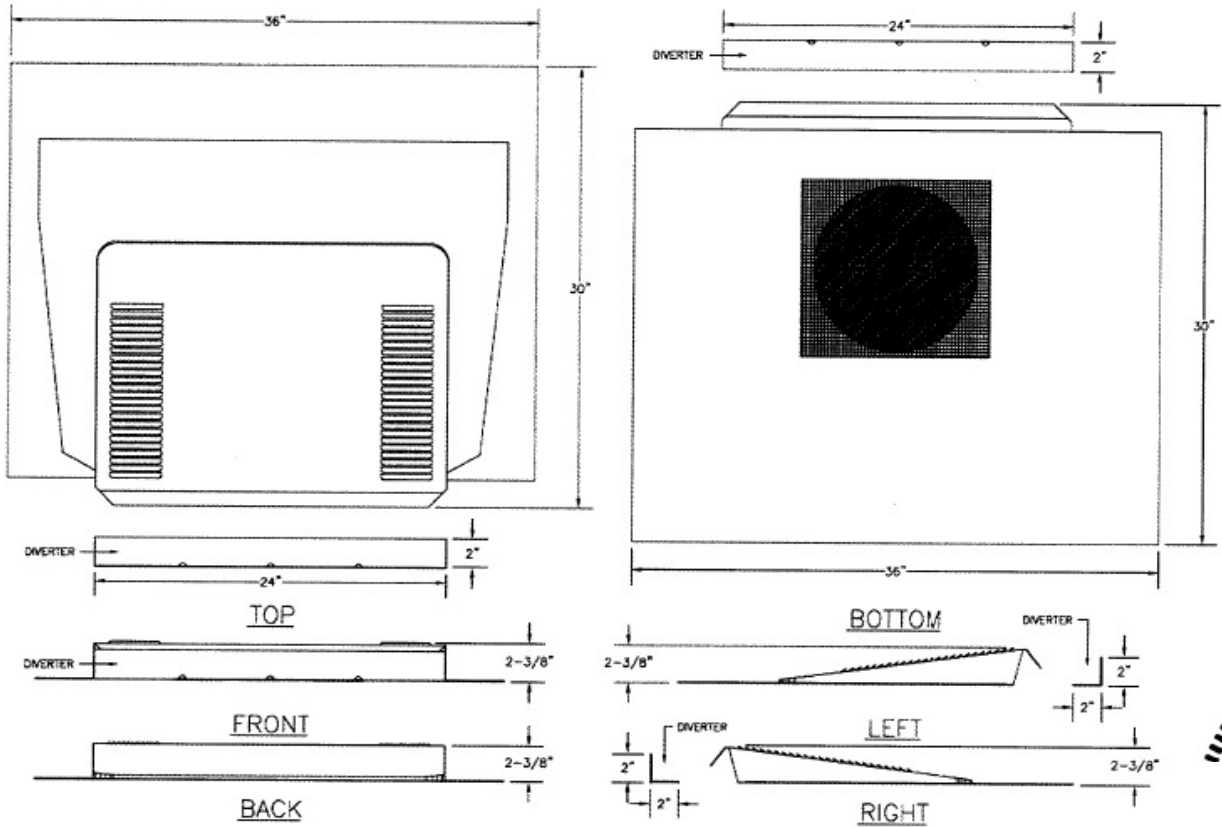

DETAIL "B"

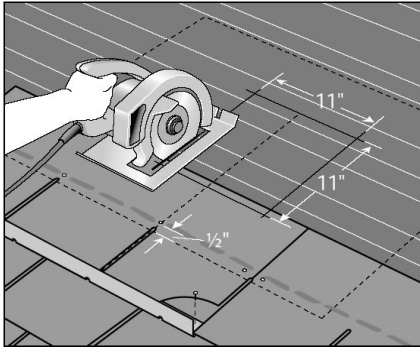

1. MARK & CUT. Align front of vent 1/2-inch below nail line and mark outline of vent for placement later. Mark outline of 11-inch by 11-inch hole. With blade set to thickness of sheathing, cut hole in roof deck. **Wind Diverter** installation should occur before securing lower course of shingles at vent placement. Mark wind diverter location (centered in alignment with vent location) 2" below primary vent outline. Apply a sufficient amount of locally approved sealant to underside of diverter. Secure diverter at 4 inches on center using roofing nails of sufficient length to penetrate sheathing.

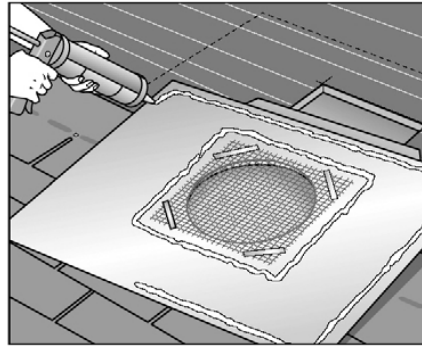

2. SEAL using sufficient amount of locally-approved sealant (Class A where required by code for flame resistance) around inner and outer flange.

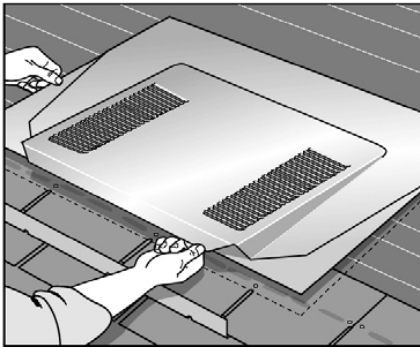

3. PLACE vent directly over 11-inch x 11-inch hole using previously marked outline as a guide.

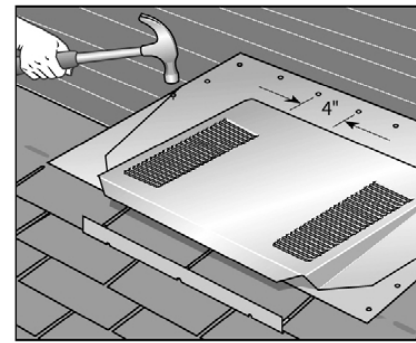

4. SECURE vent at 4-inch centers using roofing nails of sufficient length to penetrate sheathing. **SEAL** all penetrations using locally-approved sealant (Class A where required by code for flame resistance).

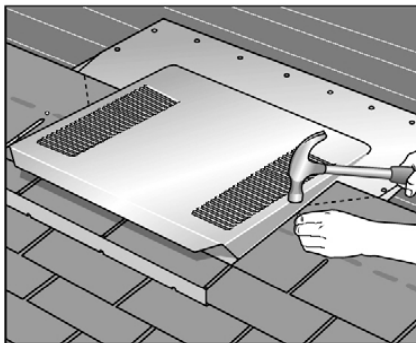

5. COVER with roofing material around vent. Based upon local best practices, a 45-degree angle cut may be made on the material terminating at the vent.

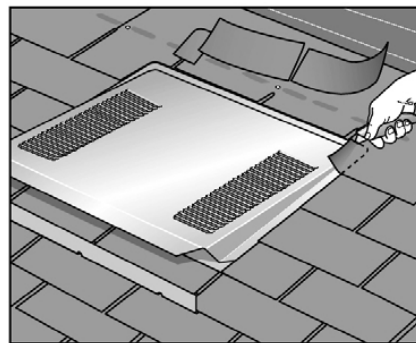

6. TRIM roofing material back 1-inch on top and sides of vent cover to allow for proper drainage.

END OF THIS ACCEPTANCE