

**REQUEST FOR WAIVER FROM ACCESSIBILITY REQUIREMENTS
OF CHAPTER 553, PART V, FLORIDA STATUTES**

Your application will be reviewed by the Accessibility Advisory Council and its recommendations will be presented to the Florida Building Commission. You will have the opportunity to answer questions and/or make a short presentation, not to exceed 15 minutes, at each meeting. The Commission will consider all information presented and the Council's recommendation before voting on the waiver request.

1. Name and address of project for which the waiver is requested.

Name: 1676 James Ave - Hostel

Address: 1676 James Avenue, Miami Beach, FL 33139

2. Name of Applicant. If other than the owner, please indicate relationship of applicant to owner and written authorization by owner in space provided:

Applicant's Name: Elsa Urquiza

Applicant's Address: 227 E Alto Rivo Drive, Miami Beach, FL 33139

Applicant's Telephone: (305) 494-9060 **FAX:** _____

Applicant's E-mail Address: elsa.urquiza@att.net

Relationship to Owner: Self

Owner's Name: Elsa Urquiza

Owner's Address: 227 E Alto Rivo Drive, Miami Beach, FL 33139

Owner's Telephone: (305) 494-9060 **FAX** _____

Owner's E-mail Address: elsa.urquiza@att.net

Signature of Owner:  _____

Contact Person: Juan R. Alvarenga, Shulman + Associates

Contact Person's Telephone: (305) 438-0609 **E-mail Address:** juan@shulman-design.com

This application is available in alternate formats upon request.
Form No. 2001-01

3. Please check one of the following:

New construction.

Addition to a building or facility.

Alteration to an existing building or facility.

Historical preservation (addition).

Historical preservation (alteration).

4. Type of facility. Please describe the building (square footage, number of floors). Define the use of the building (i.e., restaurant, office, retail, recreation, hotel/motel, etc.)

Change of use of an existing 2 story apartment building (built in 1941) to a high end Hostel. Mix of private and group rooms, 14,908 square feet total for building. No additional square footage is being added. Renovation of historic front façade and some reconfiguration of interior partitions. Existing apartment rooms are converted to hostel rooms by removing bathroom, kitchen and repurposing space to separate water closet and shower.

5. Project Construction Cost (Provide cost for new construction, the addition or the alteration):

As of this time, that total estimated cost of the renovation being performed is \$777,261

6. Project Status: Please check the phase of construction that best describes your project at the time of this application. Describe status.

Under Design Under Construction*

In Plan Review Completed*

* Briefly explain why the request has now been referred to the Commission.

Due to the change of use of the building, the local building department is requiring an elevator for the second floor. Providing access to the second floor will present a very high renovation cost to the existing project. This is an extreme hardship for a project of this scale. Therefore, the request is to waive Florida Statute Section 553.509 down to meet the Federal ADA requirements which do not require vertical accessibility in 2 story buildings.

Also the access to the existing courtyard will be from the outside new ADA ramp (see plans).

7. Requirements requested to be waived. Please reference the applicable section of Florida law. Only Florida-specific accessibility requirements may be waived.

Issue

1: Florida Statutes 553.509 Vertical Accessibility to all levels requirement. / 2010 FBC, Accessibility Code, 206.2.3 Multi-Story Buildings and Facilities

Issue

2: _____

Issue

3: _____

8. Reason(s) for Waiver Request: The Florida Building Commission may grant waivers of Florida-specific accessibility requirements upon a determination of unnecessary, unreasonable or extreme hardship. Please describe how this project meets the following hardship criteria. Explain all that would apply for consideration of granting the waiver.

The hardship is caused by a condition or set of conditions affecting the owner which does not affect owners in general.

The renovation to the building will not increase the size of the current apartment building structure. Due to change of use, the building department is requiring vertical ADA accessibility to the 2nd floor.

All amenities on second floor will be provided at ground floor. Accessibility to the ground floor has been ensured throughout with: (see attached plans)

- New ramps from the street and courtyard
- Hydraulic chair lift at lobby level to upper ground level
- 2 accessible rooms with hearing impaired + 2 hearing impaired rooms
- One accessible restroom for each sex
- Accessible routes

Substantial financial costs will be incurred by the owner if the waiver is denied.

The cost to comply if waiver is denied will represent over 12% of the costs of the renovation to date. Cost of elevator \$96,520. Cost of renovation \$777,261 (without an elevator)

[X] The owner has made a **diligent investigation** into the costs of compliance with the code, but cannot find an efficient mode of compliance. Provide detailed cost estimates and, where appropriate, photographs. Cost estimates must include bids and quotes.

Renovation budget is \$777,261. Cost to add an elevator is \$96,520. See attached budget and quotes.

9. Provide documented cost estimates for each portion of the waiver request and identify any additional supporting data which may affect the cost estimates. For example, for vertical accessibility, the lowest documented cost of an elevator, ramp, lift or other method of providing vertical accessibility should be provided, documented by quotations or bids from at least two vendors or contractors.

- a. Otis Elevator Company – \$49,720 (not including additional structure, electric work, etc.)
- b. Schindler Elevator Corp – \$43,100 (not including additional structure, electric work, etc.)
- c. See attached Cuesta Construction for budget to install full elevator - \$96,520

10. Licensed Design Professional: Where a licensed design professional has designed the project, his or her comments **MUST** be included and certified by signature and affixing of his or her professional seal. The comments must include the reason(s) why the waiver is necessary.

The cost to install and elevator and related infrastructure would be a substantial increase to the overall budget of this renovation project. Per the attached plans the building will have the required accessible rooms on the ground floor. Also all amenities on the second floor will be provided on the ground accessible floor.

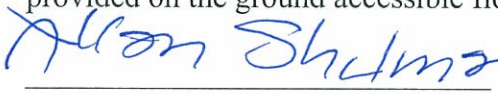

Allan T. Shulman, FAIA, LEED AP

Signature

Printed Name

Phone number (305) 438-0609

(SEAL)

CERTIFICATION OF APPLICANT:

I hereby swear or affirm that the applicable documents in support of this Request for Waiver are attached for review by the Florida Building Commission and that all statements made in this application are to the best of my knowledge true and correct.

Dated this 20th day of August, 20 12

Elsa M. Urquiza
Signature

Elsa M. Urquiza
Printed Name

By signing this application, the applicant represents that the information in it is true, accurate and complete. If the applicant misrepresents or omits any material information, the Commission may revoke any order and will notify the building official of the permitting jurisdiction. Providing false information to the Commission is punishable as a misdemeanor under Section 775.083, Florida Statutes.

REVIEW AND RECOMMENDATION BY LOCAL BUILDING DEPARTMENT.

Please state why the issue is being referred to the Florida Building Commission as well as a recommendation for disposition. The Building Official or his or her designee should review the application and indicate that to the best of his or her knowledge, all information stipulated herein is true and accurate. Further, if this project is complete, explain why it is being referred to the Commission. The Building Official or his or her designee should sign a copy of the plans accompanying this application as certification that such plans are the same as those submitted for building department review. Please reference the applicable section of the Accessibility Code.

- a. _____
- b. _____
- c. _____

Has there been any permitted construction activity on this building during the past three years? If so, what was the cost of construction?

Yes No Cost of Construction _____

Comments/Recommendation _____

Jurisdiction _____

Building Official or Designee _____

Signature

Printed Name

Certification Number

Telephone/FAX

Address: _____



Chatham Apartments Hostel

Preliminary Construction Cost Budget

July 27, 2012

GENERAL CONDITIONS	\$	58,570	8%
DEMOLITION	\$	23,420	3%
CONCRETE	\$	8,000	1%
MISC METALS	\$	1,000	0%
VANITIES	\$	9,450	1%
ROUGH CARPENTRY	\$	5,000	1%
MILLWORK	\$	4,000	1%
FIRE STOPPING	\$	2,000	0%
ROOFING	\$	7,000	1%
DOORS	\$	66,600	9%
WINDOWS	\$	22,520	3%
STUCCO	\$	7,500	1%
GYPSON SYSTEMS	\$	31,498	4%
TILE FINISHES	\$	96,740	12%
PAINTING	\$	37,792	5%
TOILET ACCESSORIES	\$	7,800	1%
PLUMBING	\$	65,100	8%
HVAC	\$	62,300	8%
FIRE SPRINKLER SYSTEM	\$	34,316	4%
ELECTRICAL	\$	149,080	19%
CHAIR LIFT	\$	20,000	3%
 SUBTOTAL	 \$	 719,686	 93%
 OVERHEAD AND FEE	 \$	 57,575	 7%
 TOTAL CONSTRUCTION BUDGET	 \$	 777,261	 100%



1414 NW 107th Avenue, Suite 401
Miami, FL 33172
O: (305) 270-3771 F: (305) 270-8885

August 17, 2012

Juan R. Alvarenga, *Assoc. AIA*
Associate
Shulman + Associates
100 NE 38 Street, Space 2
Miami, FL 33137

RE: 1676 James Avenue Hostel

Mr. Alvarenga:

Please accept this correspondence as a budget to install a new 2,100 lbs. capacity passenger elevator, elevator shaft and electrical gear for the above referenced project:

Concrete Masonry Shaft	\$30,000
2,100 lbs. Elevator	\$49,720
Roof Patch	\$ 2,000
Electrical Switch Gear	\$ 6,000
Contractor Management Fee	<u>\$ 8,800</u>
Total	\$96,520

Please note that this does not include design and permit fees.

Regards,

A handwritten signature in blue ink, appearing to read "G. Cuesta", is written over the typed name.

George L. Cuesta

Otis Elevator Company

North American Area
16200 NW 59th Avenue, Suite 109
Miami Lakes, FL 33014
Ph (305) 816-5779
Cell (305) 684-1035
Fax (860) 660-0643



Otis

A United Technologies Company

January 1, 2010

Cuesta Construction
1414 NW 107th Avenue
Suite 401
Miami, FL 33172

Re: Italian Studios Building
Miami Beach, FL

We are pleased to provide you with our proposal to furnish and install within the mentioned facility; **One (1) Otis LVMT Telescopic Hole-less Hydraulic elevator** for the sum of:

Forty Nine Thousand Seven Hundred Twenty Dollars and 00/100 (**\$49,720.00**)

Please take note of the following Attachments, which are a part of this proposal:

Attachment "A":	Scope of Work
Attachment "B":	General Clarifications/ Terms & Conditions
Attachment "C":	Alternates
Attachment "D":	Preparatory Work by Others-typical where required

We appreciate this opportunity to provide you with our proposal on this project and look forward to working with you and your project team. Upon your review / evaluation of the foregoing, please give me a call to discuss in detail / value engineering options. My direct phone line is **(305) 816-5779**.

Sincerely,

Frank Smith
Otis Elevator Company

Enclosures



Schindler

January 19, 2010

Mr. Michael Cuesta
Cuesta Construction
1414 NW 107th Ave
Suite 401
Miami, FL 33172

Project: Italian Studios Building
Location: Miami Beach, FL 33139

Dear Mr. Cuesta:

Schindler Elevator Corporation is pleased to submit our proposal to furnish and install in the above building Units: 01, Hydraulic Elevator for the sum of Forty Three Thousand One Hundred Dollars and 00/100, (\$43,100.00) if applicable including tax.

The above proposal is based on furnishing our standard equipment as defined by the attached specifications summary, in accordance with our attached standard terms and conditions. This proposal will become part of our agreement with you for this work.

We offer our proposal with the following clarifications:

1. **Please note elevator dimensions shown in building plans do not meet FBC code, clear hoistway will need to be 8'-4" X 6'-0"**
2. We will provide standard Schindler jamb mounted fixtures.
3. We have quoted standard baked enamel entrance frames and doors.
4. Quote based on standard cab finishes.
5. Please insure that elevator machine room locations on building plans meets code.
6. Please read specification summary for equipment Schindler will be supplying.

Schindler's installation schedule is based on the proper job ready conditions being available (including but not limited to dry/ complete hoistway, 3-phase power to control room, etc...). Schindler will begin manufacture of elevator components in the soonest available factory timeslot after confirmation that all preparatory work by others has been completed (see Schindler's Job Readiness Checklist). If all installation ready conditions are not available at least one (1) week prior to the projected delivery date, Schindler may elect to store the equipment off-site until installation ready conditions are confirmed by a Schindler representative (Storage fee of \$500.00/unit & \$150.00/week (no prorate) shall be the responsibility of the Contractor). At time of installation readiness confirmation, the soonest available installation team shall be assigned to the Project.

For your convenience, we will provide you with an invoice equal to 35% of the above price upon acceptance of our proposal. Payment of the initial invoice is a condition precedent to production of materials.

We will also submit to you, upon acceptance of this proposal, our detailed specifications and our standard form of contract for execution.

Please note our proposal is valid for 45 days.

You may indicate your acceptance of our proposal by signing and returning this document to me.

Respectfully submitted,

Christopher Ducale
New Equipment Sales
Schindler Elevator Corp

SHULMAN + ASSOCIATES

100 NE 38TH STREET, SPACE 2, MIAMI FLORIDA 33137
T 305 438 0609 F 305 438 0170

1676 JAMES AVE - HOSTEL

1676 JAMES AVENUE

MIAMI BEACH, FLORIDA 33139

ELEVATOR WAIVER



SHEET INDEX

G-1 COVER SHEET	A-1a GROUND FLOOR PLAN	A-4 BUILDING ELEVATIONS
G-2 SITE PLAN & ZONING	A-1b ACCESSIBLE ROUTES	A-5 BUILDING ELEVATIONS
G-3 SYMBOL, ABBREV.	A-2 SECOND FLOOR PLAN	A-6 BUILDING SECTIONS
	A-3 ROOF PLAN	

SHULMAN + ASSOCIATES

100 NE 38th Street, Space 2
Miami, FL 33137
T 305 438 0609 F 305 438 0170
www.shulman-design.com
AA 26001090

1676 JAMES AVE - HOSTEL

1676 JAMES AVENUE
MIAMI BEACH, FL 33139

ELEVATOR WAIVER

ALLAN T. SHULMAN, FAIA, LEED® AP
AR 0012763

NO	DESCRIPTION	DATE

08.20.12
12018
Project Number

COVER SHEET

G-1



2 LOCATION MAP
G-2 N.T.S.

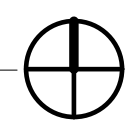

PROJECT ZONING DATA		
GENERAL		
ZONING DISTRICT	CD-3, MUSEUM HISTORIC DISTRICT	
LOT AREA	12,000 SF	
FLOOR AREA RATIO	2.25	
BUILDING AREA	ALLOWED/REQUIRED	PROPOSED
OCCUPANCY GROUP	R-2 [APARTMENT HOUSE]	R-1 [HOTEL (transient)]
STORIES	7 STORIES	2 STORIES (EXISTING)
HEIGHT	50'	21'-6" (EXISTING)
EXISTING/PROPOSED FLOOR AREA		
EXISTING FLOOR AREA		
GROUND FLOOR	7,454 SF	
2ND FLOOR	7,454 SF	
TOTAL	14,908 SF	
PROPOSED UNIT SUMMARY		
	ALLOWED	PROVIDED
TOTAL # HOTEL UNITS		29
HOTEL UNITS 300-335 SF	15% = 4	4
HOTEL UNITS 335+ SF	85% = 25	25
SETBACK REQUIREMENTS AS PER SECTION 142-247		
ALL EXISTING TO REMAIN		

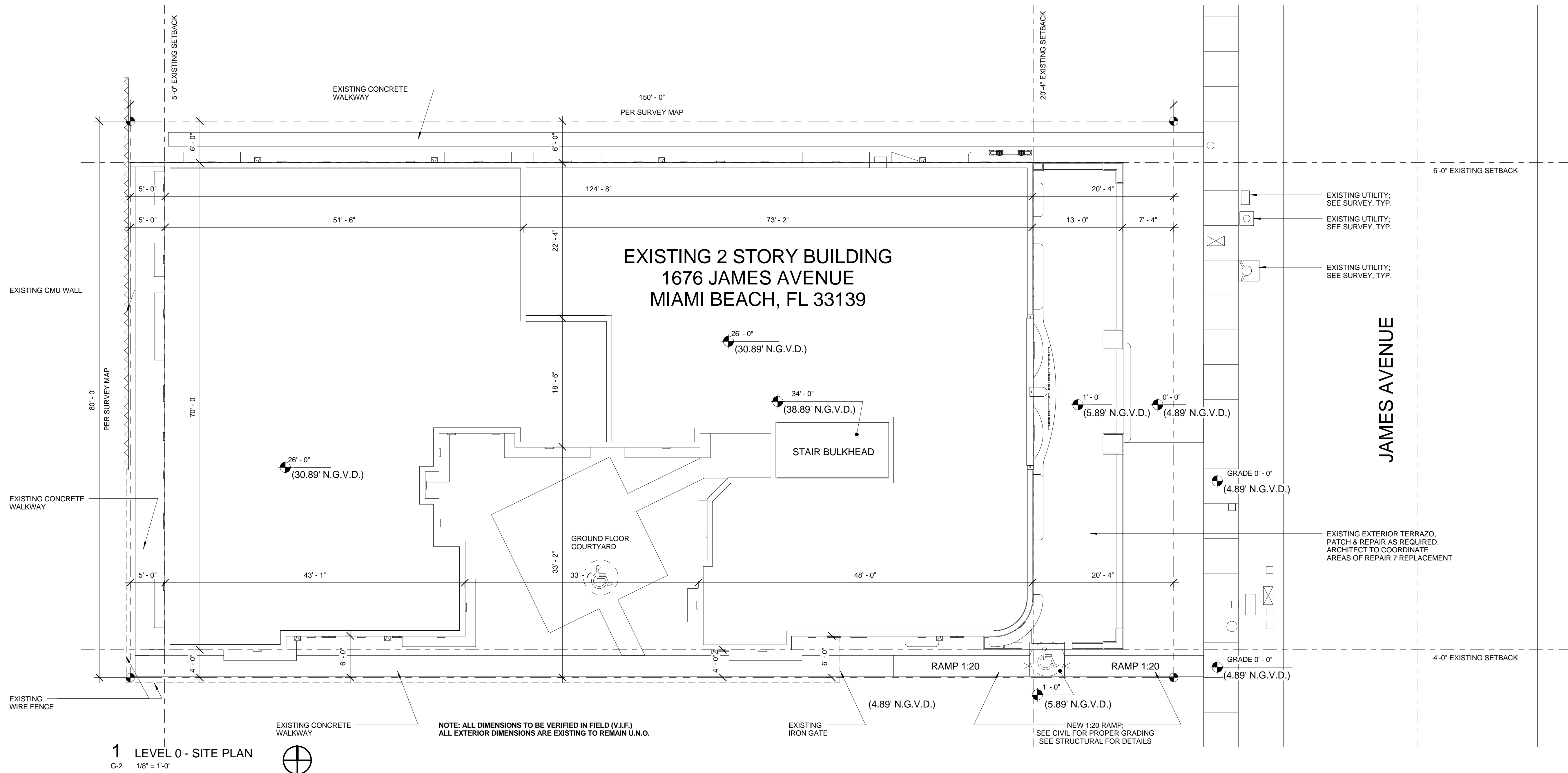

SHULMAN + ASSOCIATES
100 NE 38th Street, Space 2
Miami, FL 33137
T 305 438 0609 F 305 438 0170
www.shulman-design.com
AA 26001090

1676 JAMES AVE - HOSTEL
1676 JAMES AVENUE
MIAMI BEACH, FL 33139

ELEVATOR WAIVER

ALLAN T. SHULMAN, FAIA, LEED™ AP
AR 0012763

NO	DESCRIPTION	DATE

08.20.12
12018
Project Number

SITE PLAN & ZONING
G-2

NO	DESCRIPTION	DATE

08.20.12
 12018
 Project Number

GROUND FLOOR PLAN

A-1a

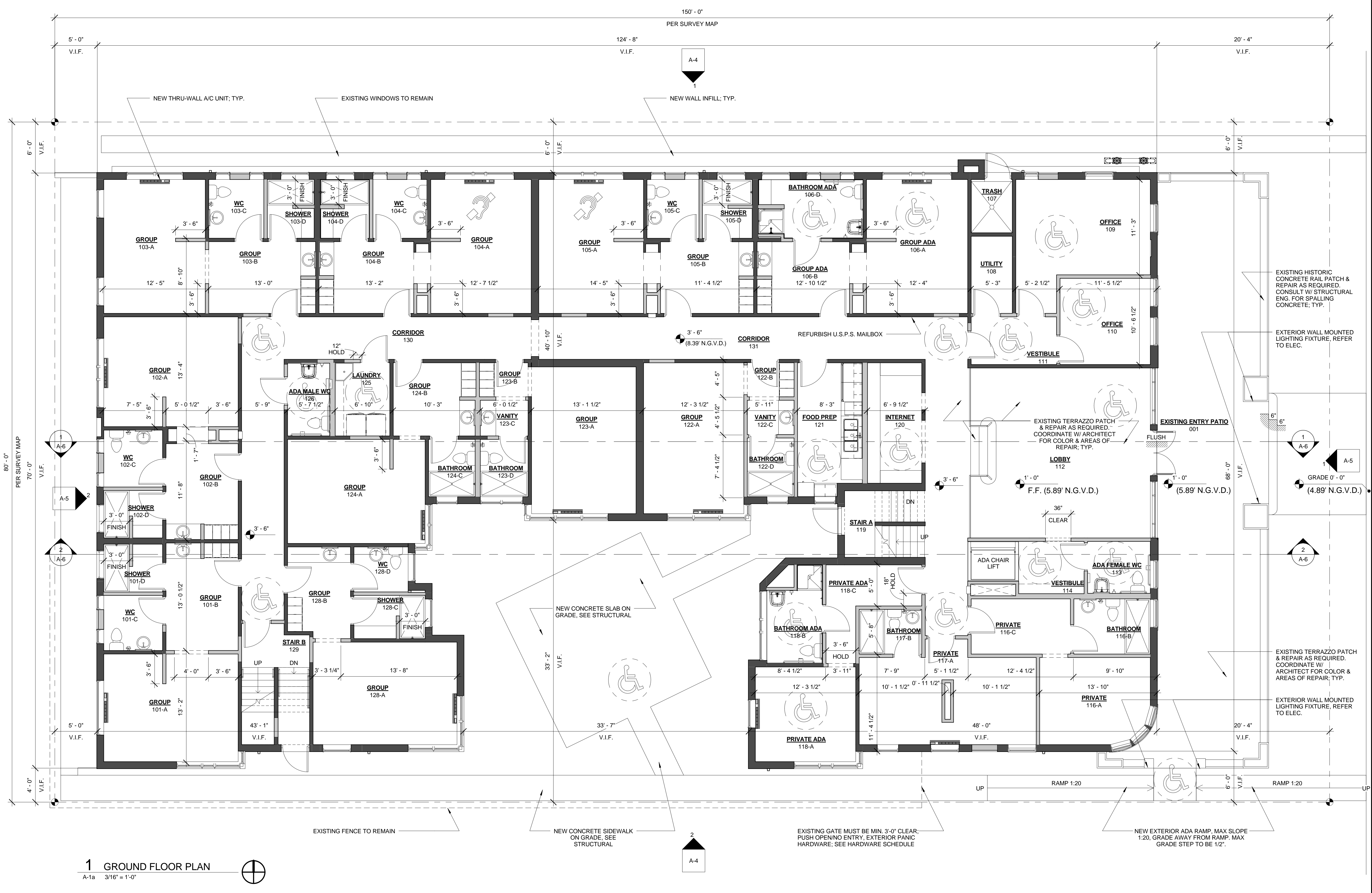

1 GROUND FLOOR PLAN
 A-1a 3/16" = 1'-0"

ACCESSIBLE GUESTROOM DESIGNATIONS:

SYMBOLS	DESCRIPTION	COUNT	
	ACCESSIBLE GUESTROOM WITH SHOWER & WITH HEARING-IMPAIRED FEATURES	2	PER FBC 2010, ACCESSIBILITY, TABLE 224.2 GUEST ROOMS WITH MOBILITY FEATURES: 2 REQ'D - 2 PROVIDED
	NON-ACCESSIBLE HEARING-IMPAIRED GUESTROOMS	2	PER FBC 2010, ACCESSIBILITY, TABLE 224.4 GUEST ROOMS WITH COMMUNICATION FEATURES: 4 REQ'D - 4 PROVIDED* *2 ACCESSIBLE + 2 NON-ACCESSIBLE

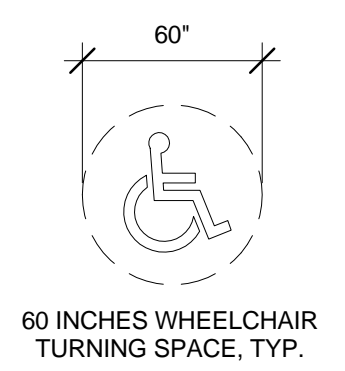

REFER TO A-1b FOR GROUND FLOOR ACCESSIBLE AREAS AND ROUTES

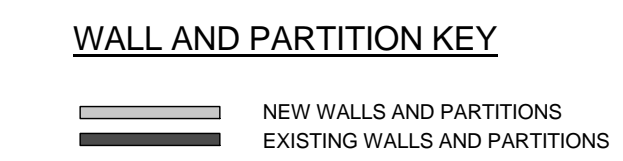

EXISTING HISTORIC CONCRETE RAIL PATCH & REPAIR AS REQUIRED. CONSULT W/ STRUCTURAL ENG. FOR SPALLING CONCRETE, TYP.

EXISTING TERRAZZO PATCH & REPAIR AS REQUIRED. COORDINATE W/ ARCHITECT FOR COLOR & AREAS OF REPAIR, TYP.

EXISTING TERRAZZO PATCH & REPAIR AS REQUIRED. COORDINATE W/ ARCHITECT FOR COLOR & AREAS OF REPAIR, TYP.

EXISTING ENTRY PATIO

EXISTING GATES MUST BE MIN. 3'-0" CLEAR. PUSH OPENING ENTRY. EXTERIOR PANIC HARDWARE. SEE HARDWARE SCHEDULE

NEW EXTERIOR ADA RAMP, MAX SLOPE 1:20. GRADE AWAY FROM RAMP. MAX GRADE STEP TO BE 1/2".

NO	DESCRIPTION	DATE

08.20.12
 12018
 Project Number

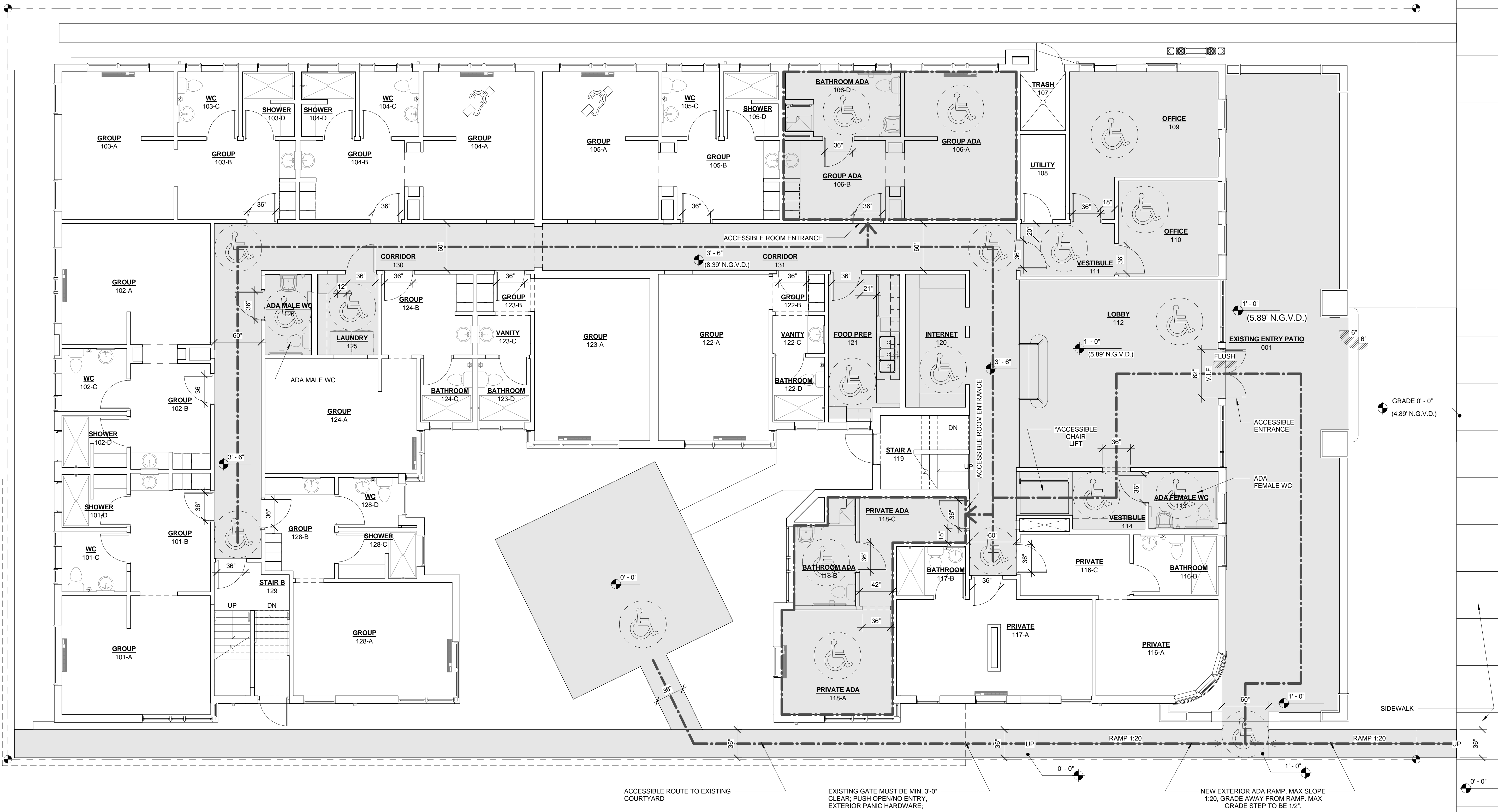

1 GROUND FLOOR ACCESSIBILITY PLAN
 A-1b 3/16" = 1'-0"

ACCESSIBLE GUESTROOM DESIGNATIONS:			
SYMBOLS	DESCRIPTION	COUNT	
	ACCESSIBLE GUESTROOM WITH SHOWER & WITH HEARING-IMPAIRED FEATURES	2	PER FBC 2010, ACCESSIBILITY, TABLE 224.2 GUEST ROOMS WITH MOBILITY FEATURES 2 REQ'D - 2 PROVIDED
	NON-ACCESSIBLE HEARING-IMPAIRED GUESTROOMS	2	PER FBC 2010, ACCESSIBILITY, TABLE 224.4 GUEST ROOMS WITH COMMUNICATION FEATURES 4 REQ'D - 4 PROVIDED* *2 ACCESSIBLE + 2 NON-ACCESSIBLE

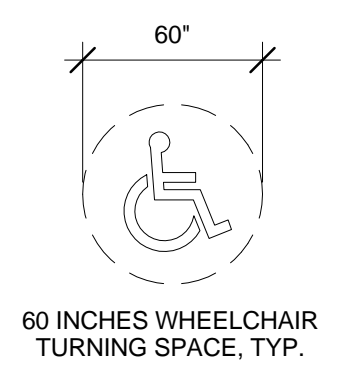

*ACCESSIBLE CHAIR LIFT TO BE:
 SAVARIA V-1504 0 STD TYPE 2
 ADA HYDRAULIC PLATFORM CHAIR LIFT
 2 STOP - 30" VERTICAL TRAVEL
 CONTACT:
 FLORIDA LIFTS, LLC.
 c/o: BRUCE LEASON
 P.O. BOX 740708
 BOYTON BEACH, FL 33474-0708
 561.353.5438 T
 531.244.7580 F
 info@floridalifts.com

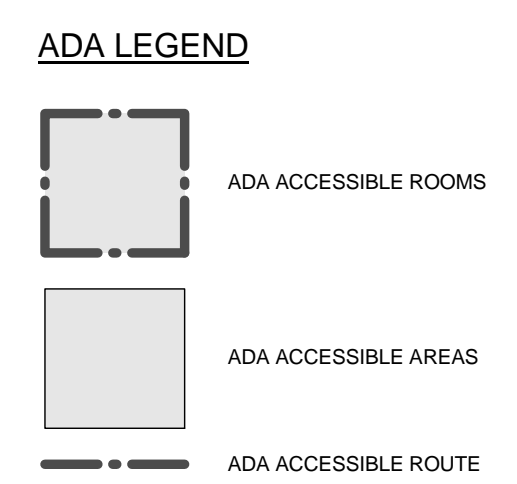

ACCESSIBLE ROUTE TO EXISTING COURTYARD

EXISTING GATE MUST BE MIN. 3'-0" CLEAR; PUSH OPENING ENTRY; EXTERIOR PANIC HARDWARE;

NEW EXTERIOR ADA RAMP; MAX SLOPE 1:20, GRADE AWAY FROM RAMP; MAX GRADE STEP TO BE 1/2".



SHULMAN + ASSOCIATES
 100 NE 38th Street, Space 2
 Miami, FL 33137
 T 305 438 0609 F 305 438 0170
 www.shulman-design.com
 AA 26001090

1676 JAMES AVE - HOSTEL
 1676 JAMES AVENUE
 MIAMI BEACH, FL 33139
ELEVATOR WAIVER

ALLAN T. SHULMAN, FAIA, LEED® AP
 AR 0012763

NO	DESCRIPTION	DATE

08.20.12
 12018
 Project Number

SECOND FLOOR PLAN

A-2



1 SECOND FLOOR PLAN
 A-2 3/16" = 1'-0"

WALL AND PARTITION KEY
 — NEW WALLS AND PARTITIONS
 — EXISTING WALLS AND PARTITIONS

SAME AMENITIES FROM SECOND FLOOR TO BE PROVIDED ON GROUND FLOOR

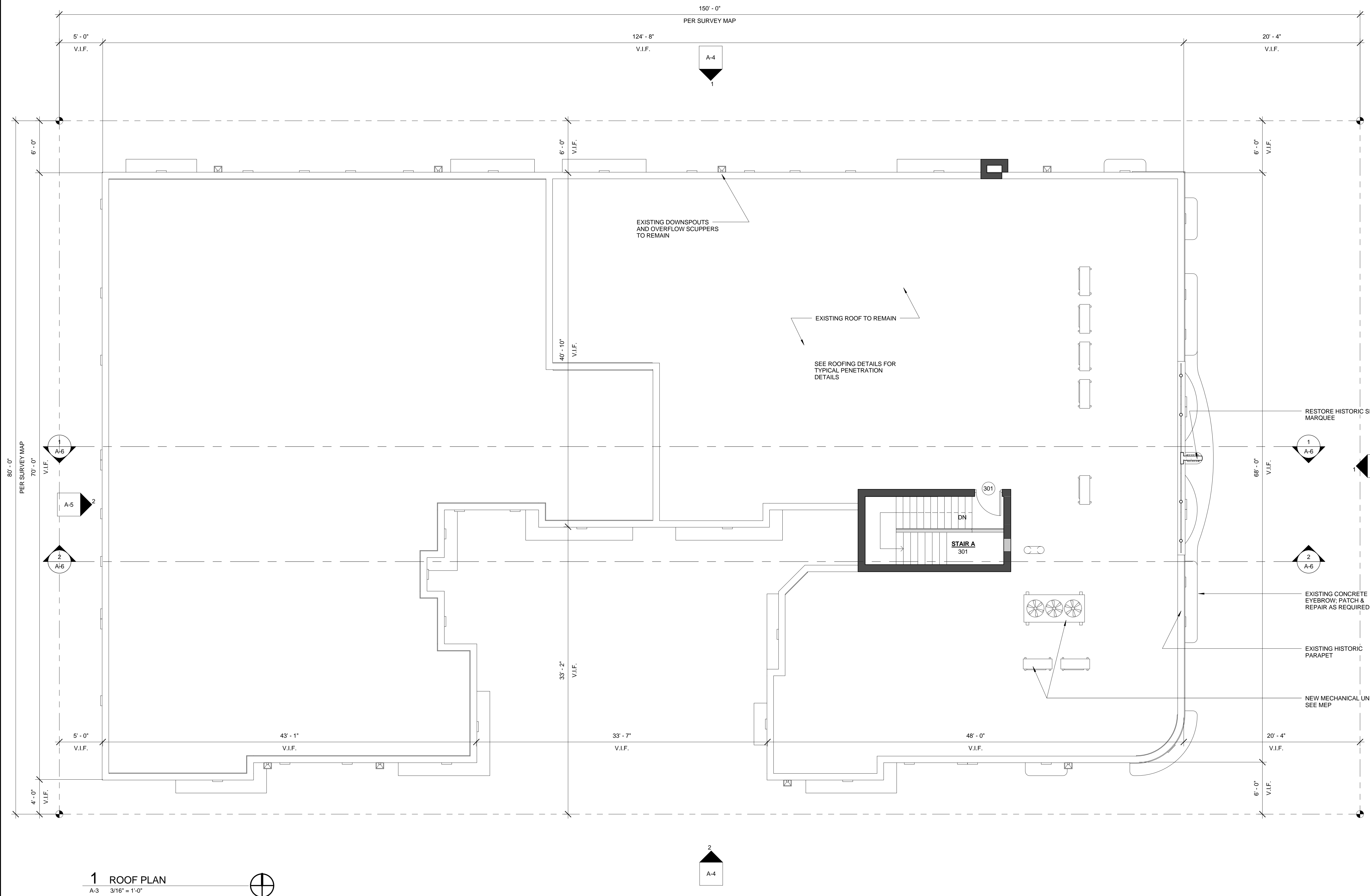

1 ROOF PLAN
A-3 3/16" = 1'-0"

WALL AND PARTITION KEY
 ——— NEW WALLS AND PARTITIONS
 ——— EXISTING WALLS AND PARTITIONS



SHULMAN + ASSOCIATES
 100 NE 38th Street, Space 2
 Miami, FL 33137
 T 305 438 0609 F 305 438 0170
 www.shulman-design.com
 AA 26001090

1676 JAMES AVE - HOSTEL
 1676 JAMES AVENUE
 MIAMI BEACH, FL 33139
ELEVATOR WAIVER

ALLAN T. SHULMAN, FAIA, LEED™ AP
 AR 0012763

NO	DESCRIPTION	DATE

08.20.12
 12018
 Project Number

ROOF PLAN
A-3

NO	DESCRIPTION	DATE

08.20.12
 12018
 Project Number



2 SOUTH ELEVATION
 A-4 3/16" = 1'-0"

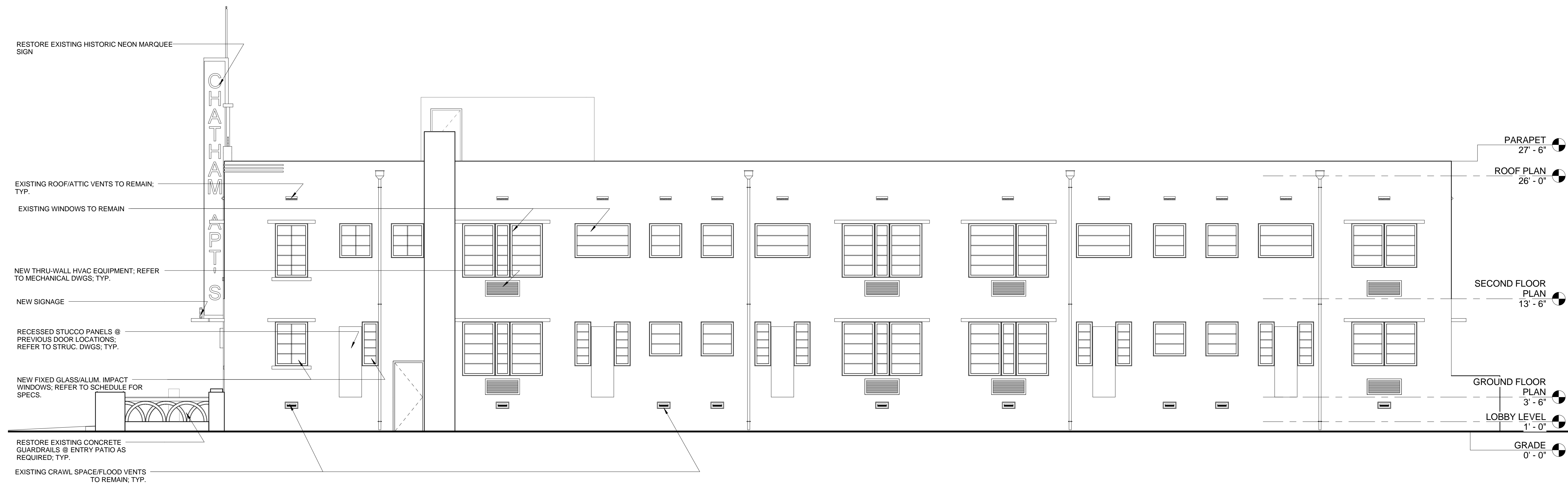

1 NORTH ELEVATION
 A-4 3/16" = 1'-0"

RESTORE EXISTING HISTORIC NEON MARQUEE SIGN

PARAPET
27' - 6"

ROOF PLAN
26' - 0"

EXISTING ROOF/ATTIC VENTS TO REMAIN; TYP.

EXISTING WINDOWS TO REMAIN

NEW THRU-WALL HVAC EQUIPMENT; REFER TO MECHANICAL DWGS; TYP.

NEW SIGNAGE
SECOND FLOOR PLAN
13' - 6"

RECESSED STUCCO PANELS @ PREVIOUS DOOR LOCATIONS; REFER TO STRUC. DWGS

NEW FIXED GLASS/ALUM. IMPACT WINDOWS; REFER TO SCHEDULE FOR SPECS.

GROUND FLOOR PLAN
3' - 6"

LOBBY LEVEL
1' - 0"

GRADE
0' - 0"

NEW ADA ACCESSIBLE RAMP

EXTERIOR WALL MOUNTED LIGHTING FIXTURE; REFER TO ELEC. DWGS

RESTORE EXISTING CONCRETE GUARDRAILS @ ENTRY PATIO AS REQUIRED; TYP.

EXISTING CRAWL SPACE/FLOOD VENTS TO REMAIN; TYP.

RESTORE EXISTING HISTORIC NEON MARQUEE SIGN

EXISTING ROOF/ATTIC VENTS TO REMAIN; TYP.

EXISTING WINDOWS TO REMAIN

NEW THRU-WALL HVAC EQUIPMENT; REFER TO MECHANICAL DWGS; TYP.

NEW SIGNAGE

RECESSED STUCCO PANELS @ PREVIOUS DOOR LOCATIONS; REFER TO STRUC. DWGS; TYP.

NEW FIXED GLASS/ALUM. IMPACT WINDOWS; REFER TO SCHEDULE FOR SPECS.

RESTORE EXISTING CONCRETE GUARDRAILS @ ENTRY PATIO AS REQUIRED; TYP.

EXISTING CRAWL SPACE/FLOOD VENTS TO REMAIN; TYP.

PARAPET
27' - 6"

ROOF PLAN
26' - 0"

SECOND FLOOR PLAN
13' - 6"

GROUND FLOOR PLAN
3' - 6"

LOBBY LEVEL
1' - 0"

GRADE
0' - 0"

1676 JAMES AVE - HOSTEL
 1676 JAMES AVENUE
 MIAMI BEACH, FL 33139

ELEVATOR WAIVER

ALLAN T. SHULMAN, FAIA, LEED™ AP
 AR 0012763

NO	DESCRIPTION	DATE

08.20.12
 12018
 Project Number

BUILDING
 ELEVATIONS

A-5

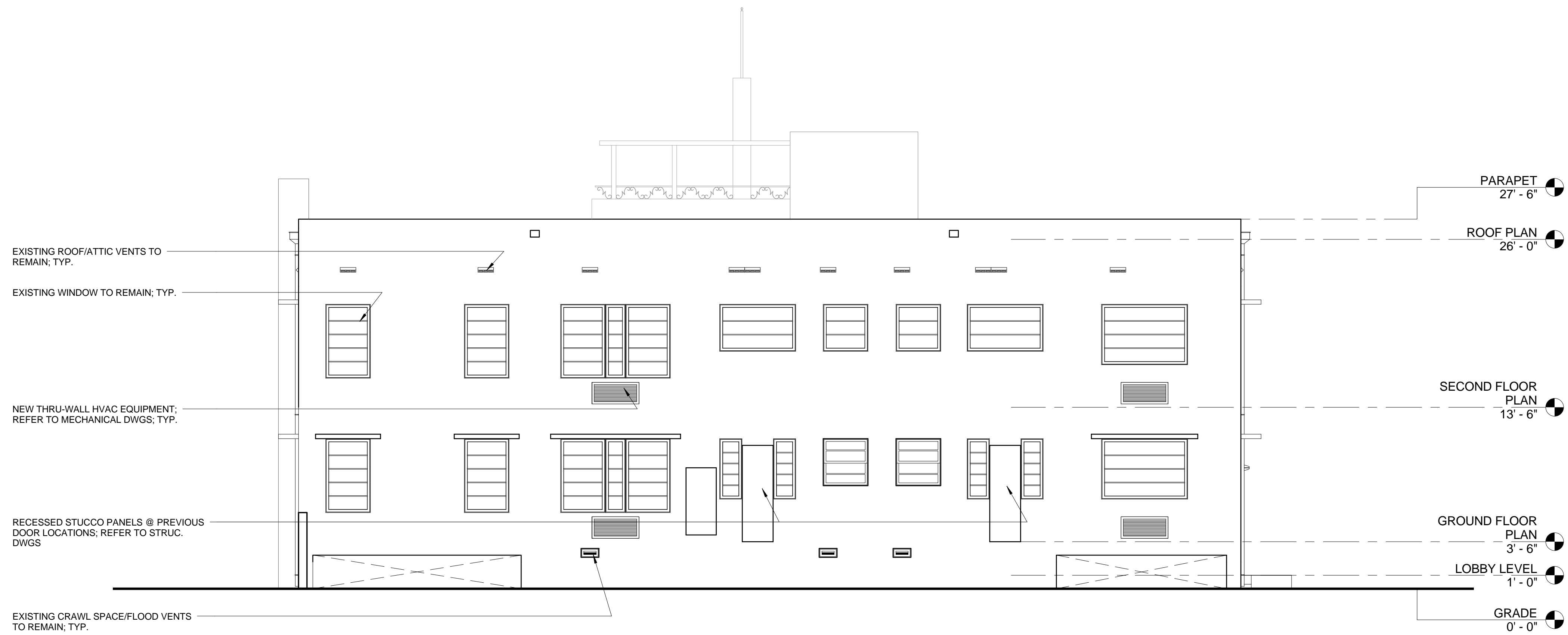

2 WEST ELEVATION
 A-5 3/16" = 1'-0"

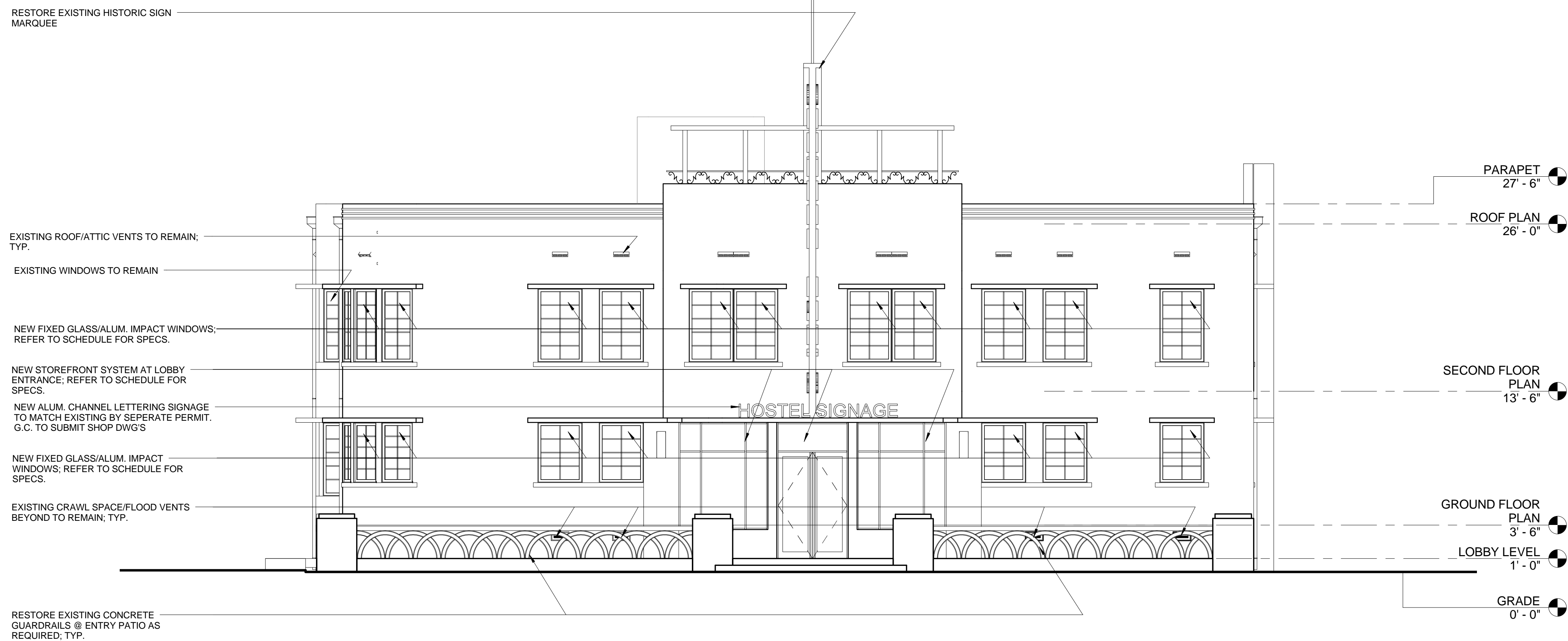

1 EAST ELEVATION
 A-5 3/16" = 1'-0"

GENERAL NOTE:
 THIS NOTE ONLY PERTAINS TO FACADE OF EXISTING BUILDING.
 STUCCO TO BE PATCHED AND REPAIRED PER ASTM C1063 STANDARDS.
 PROVIDE TWO-COAT STUCCO APPLICATION OF SCRATCH AND FINISH COAT.
 IF CRACKS ARE VISIBLE FROM 10 FT. AWAY OR ARE A SOURCE OF LEAKING IT SHOULD BE PATCHED.
 APPLY ACRYLBOND BONDING AGENT ON EXISTING WALLS TO BE PATCHED BEFORE STUCCO IS APPLIED.

NO	DESCRIPTION	DATE

08.20.12
 12018
 Project Number

BUILDING SECTIONS

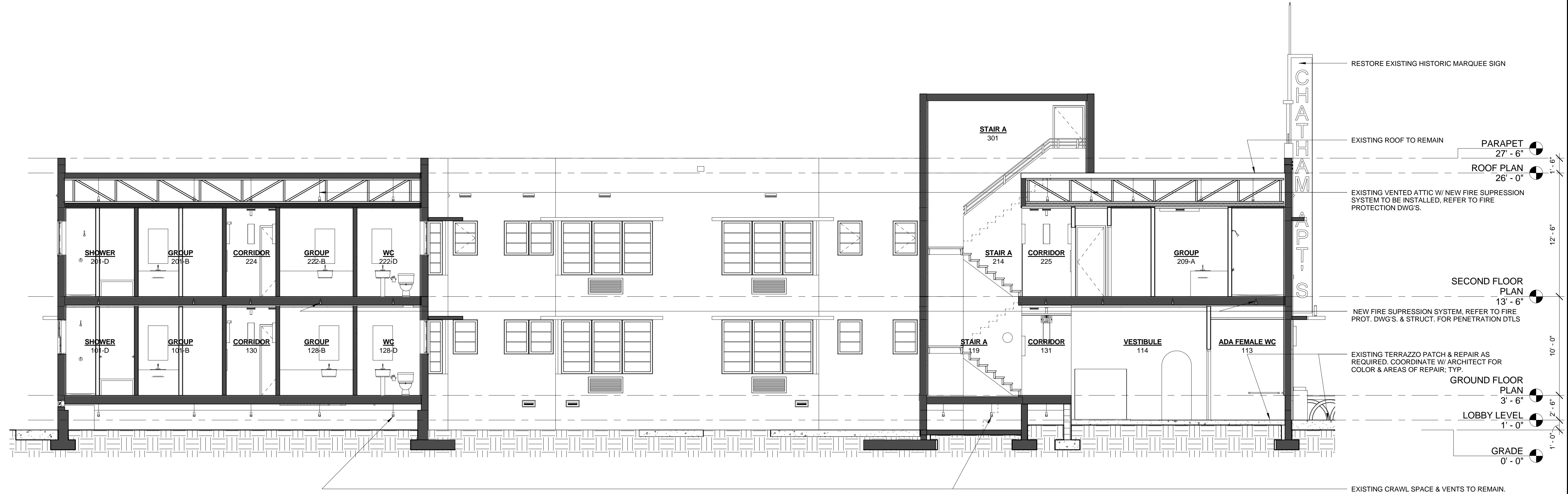

2 BUILDING SECTION
 A-6 3/16" = 1'-0"

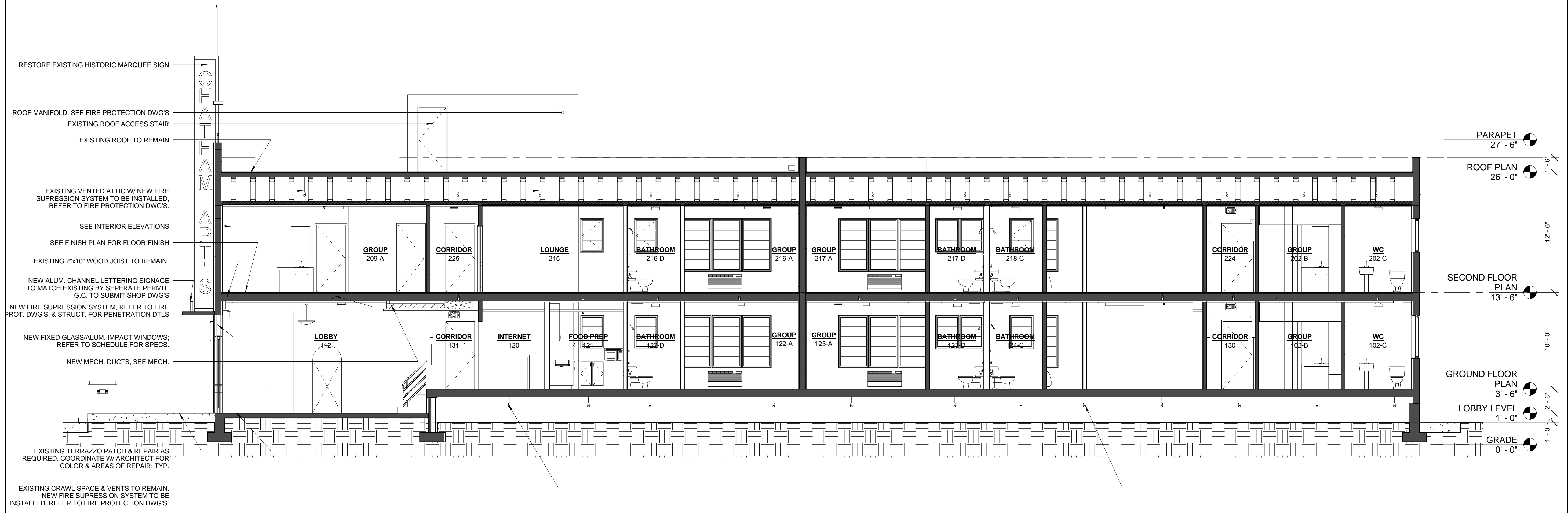

1 BUILDING SECTION
 A-6 3/16" = 1'-0"



1414 NW 107th Avenue, Suite 401
Miami, FL 33172
T: (305) 270-3731
F: (305) 270-8885

Date: **October 23, 2012**

Project: **1676 JAMES AVENUE HOSTEL - Budget for ADA Costs
MIAMI BEACH, FL 33139**

Architect: **SHULMAN + ASSOCIATES**

<u>CODE</u>	<u>ITEM DESCRIPTION</u>	<u>AMOUNT</u>
01000	General Conditions	\$ 3,900
02000	Demolition	\$ 1,100
03300	Cast in Place Concrete	\$ 2,600
08100	Doors and Hardware	\$ 3,600
08460	Glass Entrances and Windows	\$ 1,500
09260	Drywall	\$ 1,800
09300	Tile Flooring	\$ 5,000
09600	Terrazzo	\$ 5,500
09900	Painting	\$ 1,400
10810	Toilet Accessories	\$ 1,100
14200	Lift	\$ 15,500
15400	Plumbing	\$ 8,560
15700	HVAC	\$ 800
16000	Electrical and Fire Alarm	\$ 2,800
16005	Lighting Package	\$ 500
	SUB TOTAL	\$ 55,660
	OVERHEAD AND FEE	\$ 4,500
	TOTAL	\$ 60,160



1414 NW 107th Avenue, Suite 401
Miami, FL 33172
T: (305) 270-3731
F: (305) 270-8885

Date: **October 23, 2012**

Project: **1676 JAMES AVENUE HOSTEL - Budget for ADA Costs
MIAMI BEACH, FL 33139**

Architect: **SHULMAN + ASSOCIATES**

<u>CODE</u>	<u>ITEM DESCRIPTION</u>	<u>AMOUNT</u>
01000	General Conditions	\$ 3,900
02000	Demolition	\$ 1,100
03300	Cast in Place Concrete	\$ 2,600
08100	Doors and Hardware	\$ 3,600
08460	Glass Entrances and Windows	\$ 1,500
09260	Drywall	\$ 1,800
09300	Tile Flooring	\$ 5,000
09600	Terrazzo	\$ 5,500
09900	Painting	\$ 1,400
10810	Toilet Accessories	\$ 1,100
14200	Lift	\$ 15,500
15400	Plumbing	\$ 8,560
15700	HVAC	\$ 800
16000	Electrical and Fire Alarm	\$ 2,800
16005	Lighting Package	\$ 500
	SUB TOTAL	\$ 55,660
	OVERHEAD AND FEE	\$ 4,500
	TOTAL	\$ 60,160