

**A-HMB14**  
 (QTY 4)  
 HEX BOLT  
 1/4-20 UNC X 1 1/2"  
 18-8 STAINLESS STEEL

**A-ARS4**  
 (QTY 4)  
 AVK FASTENER  
 1/4-20 UNC

**A-CLIP (QTY 4)**  
 EQUIPMENT CLIP  
 2" X 6" X 1.5"  
 STEEL, ZINC PLATE

**A-SDS14 (QTY 8)**  
 SELF DRILLING SCREW  
 HEX HEAD NEPORENE WASHER  
 410 STAINLESS STEEL

**COUPLER .75 HEX**  
 1/2-13 UNC

**ROD 1/2-13 UNC**

**A-EXT7 (QTY 1)**  
 ANCHOR EXTENSION  
 7 7/8" 1/2"  
 STEEL, HDG  
 COMES WITH MESA.

**A-DCP (QTY 1)**  
 DOUBLE COUPLER  
 1 3/4", X 1" X 3/4"  
 STEEL, HDG

**A-HN12 (QTY 2)**  
 1/2-13 UNC  
 NUT STEEL, HDG

**A-HB34 (QTY 1)**  
 HEX BOLT  
 1/2-13 X 3/4 UNC  
 STEEL, HDG

**A-SW12 (QTY 1)**  
 1/2 SPLIT WASHER  
 STEEL, HDG

**A-WF212 (QTY 1)**  
 FLAT WASHER 2 1/2"  
 STEEL, HDG

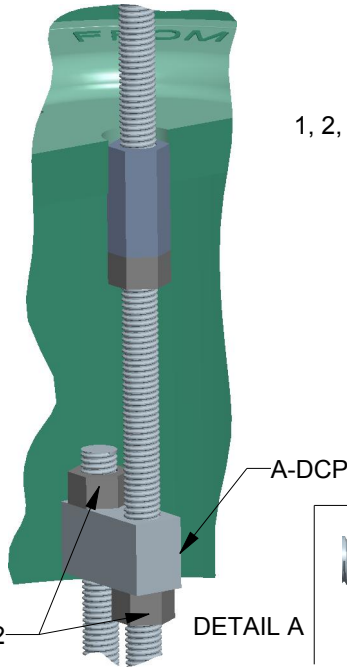
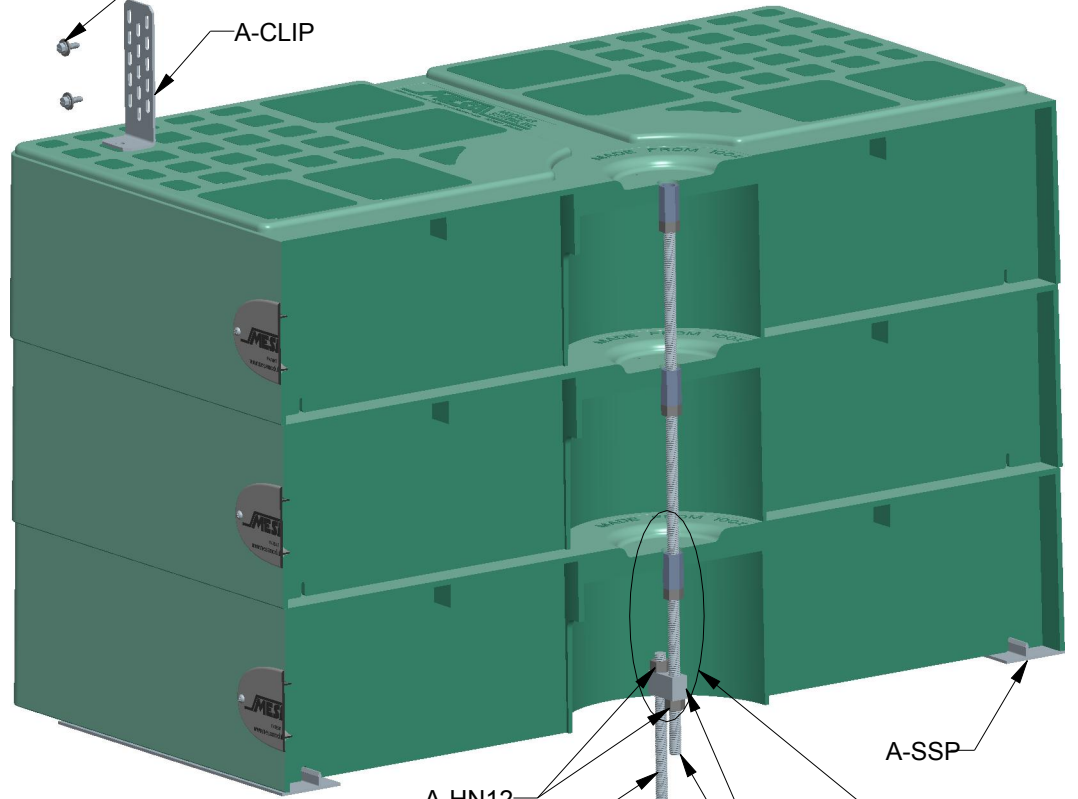
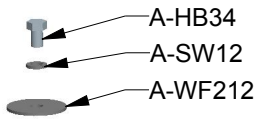
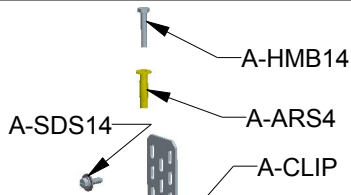

1, 2, OR 3 MESAS

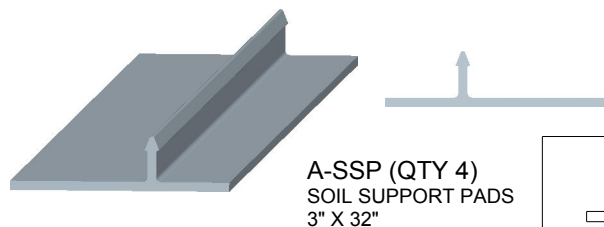

PATENT PENDING



ST PETERSBURG FL, (727) 623-4125

DESIGNED: JOE NAVARRO 8/10	APPROVED:	DO NOT SCALE DRAWING	INTERPRET PER ANSI Y14.5	NAME: <b>EARTH ANCHOR ASSEMBLY</b>	
DOCUMENT CONTENTS ARE "INTELLECTUAL PROPERTY OF MESA MODULAR SYSTEMS INC." WHICH ARE PROPRIETARY AND CONFIDENTIAL. AND MAY NOT BE DIVULGED IN WHOLE OR PART WITHOUT AUTHORIZED PERMISSION OF MESA MODULAR SYSTEMS INC, COPYRIGHT 2010 MESA MODULAR SYSTEMS INC. PATENT PENDING		SHEET: 1 OF 1	SIZE: <b>A</b>	DRAWING NUMBER: <b>EAA42</b>	REV: <b>A</b>
		SCALE: 0.125	UNITS: INCH		

# MESA Installation Instructions

## Earth Anchor System

### Safety First

- Any time work is to be performed below ground, extreme care must be taken to avoid contact with underground utilities, irrigation lines etc. When installing the MESA anchor the same precautions must precede the actual work.
- Make sure there are no underground utilities where you will be working. You can call 811 (<http://www.callsunshine.com/>) to locate most power lines. Phone, cable, irrigation and water lines on private property are not part of the program. *Your safety is your responsibility.*
- Contact MESA Modular Systems, Inc. with any questions relating to these instructions.

### Getting Ready

- Soil and surface conditions will vary from site to site. The ground must be level and compact to adequately support the MESA and equipment. Soft clays, mucky (organic) soils, or other similar conditions are not acceptable. In the event soil conditions are less than sufficient, steps to correct those conditions are the responsibility of the installation crew. Additionally, if the soil in the installation location has been disturbed, it must be properly compacted prior to MESA installation.

### You'll need:

- 3/4" crescent wrenches (2)
- 7/16" nut driver
- 5/16" nut driver
- 8 lb sledge hammer
- 3/8 variable speed drill
- 3/8" drill bit
- level (optional)
- plus the MESA Tool Kit.

- After completing the preparation of the site, locate the center point of the MESA installation and use the drive tool and a 8 lb sledge hammer to make a starter hole 18-20" deep. Wobble out the hole and remove the tool.

Screw the 44 x 1/2" threaded rod into the anchor shackle until it bottoms out.

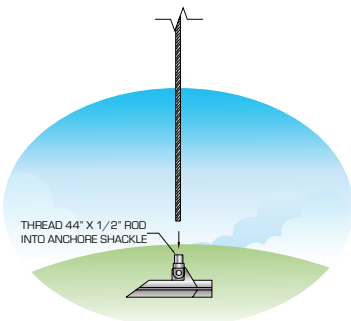

- Insert the drive tool into the female end of the anchor.

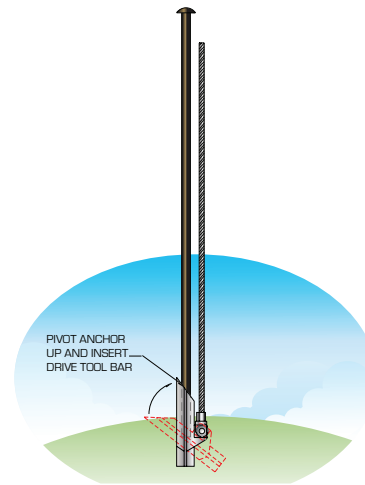

- Hold the threaded rod and the drive tool together in one hand and use the sledge to hammer the drive tool, threaded rod and anchor into the ground.

When you're done there will be 1-1/2" MAX of threaded rod above ground. Remove the drive tool.

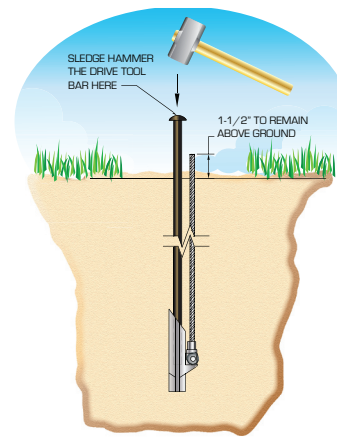

- Place the 6 x 6 anchor setting plate over the threaded rod and hand-tighten a 1/2" hex nut down to the plate.

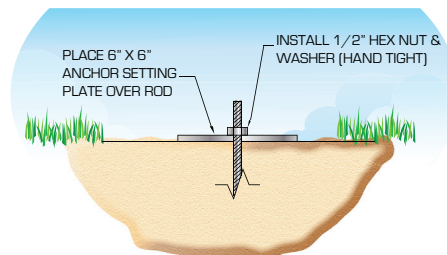

- With the deep wall socket and 3/8" drill, tighten down on the hex nut. As the threaded rod is drawn up the anchor will set itself to the anchored position. There must be 4" to 6" of threaded rod above ground when the anchor is set. Remove the nut and anchor setting plate and keep for the next installation.

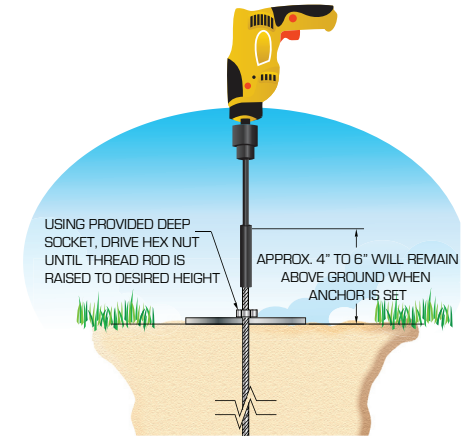

- Start by threading a 1/2" locking hex nut down the anchor rod to about 4" from the ground. Follow with the double coupler and lock the two together. The exact height is not important. Thread a 1/2" locking hex nut onto the end of the 7-7/8" anchor extension that comes with each MESA. Thread the 7-7/8" anchor extension down into the remaining hole in the double coupler. Adjust the coupler height to 7-3/8" from the grade level and lock the two together. The height should be set slightly lower (1/4") than the circular indent on top of the MESA unit.

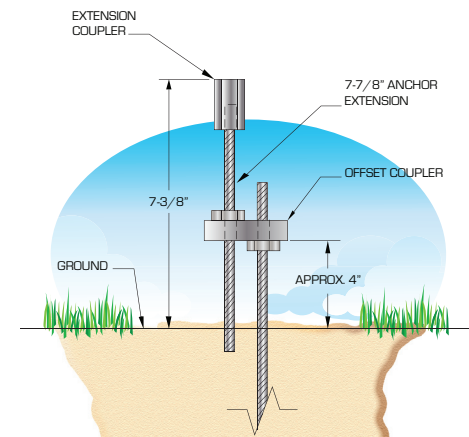

- 7 Turn the first MESA upside down and attach the four soil support pads (32 x 3" L shapes) by pressing them into the slots. Place the MESA unit into position, centering the coupler end of the anchor extension over the center hole. Check to make sure it is sitting flat and level.

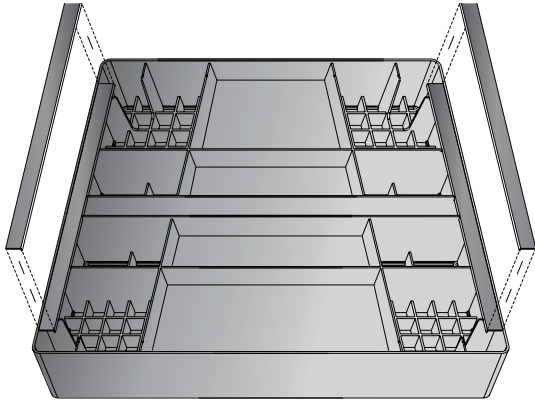

- **Trouble shooting:** you may need to re-adjust the height of the anchor extension to achieve a level 1/4" below the top of the MESA.)

- 8 Once the correct height is set for the first unit, simply add one anchor extension for each additional MESA unit. Tighten each threaded rod to the one below until the rods touch - no additional height adjustment is necessary. The MESA units will interlock. Place the 2-1/2" flat washer followed by the lock washer on the center hole and use the 3/4 x 1/2" bolt to anchor all three MESAs as one assembly. The MESA units should be snug to the ground with no slack under the washer.

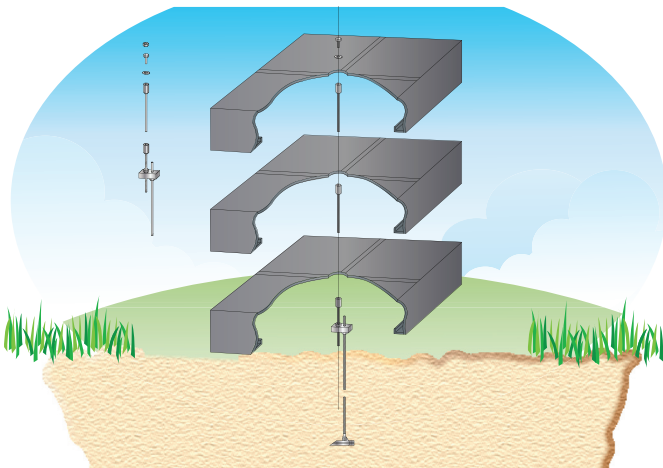

- 9 Using care, place the condensing unit on top of the MESA. Do not drop! The raised areas on the top surface of the MESA will indicate the best position for the unit and fastening clips. Determine the correct condenser position and all 4 clip locations before you drill.

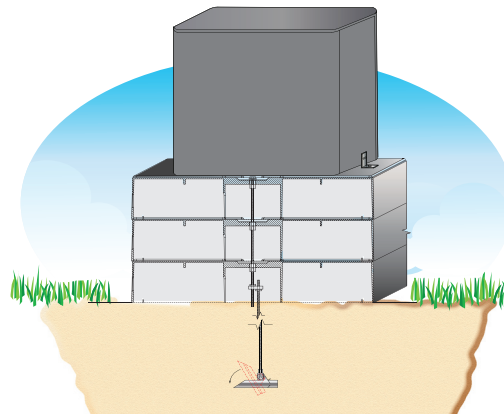

- 10 Attach the clips to the MESA first - use a 3/8" bit to drill through the hole in the clip and through the top of the MESA. With the clip placed over the hole, push an AVK fastener through the hole in the clip and through the hole in the MESA. The fastener sits on top of the clip - not under it.

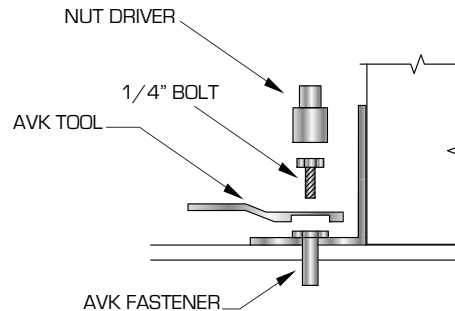

- 11 Place the fastener tool over the fastener flange and thread a 1/4" x 20 x 1-1/4" S.S. bolt through the hole in the tool and into the fastener a few turns to get it started. Use a variable speed drill with a 7/16" nut driver - apply some downward pressure and turn the bolt until it pulls the fastener tight. The fastener tool helps to keep the fastener from spinning out. Remove the bolt to release the fastener tool.

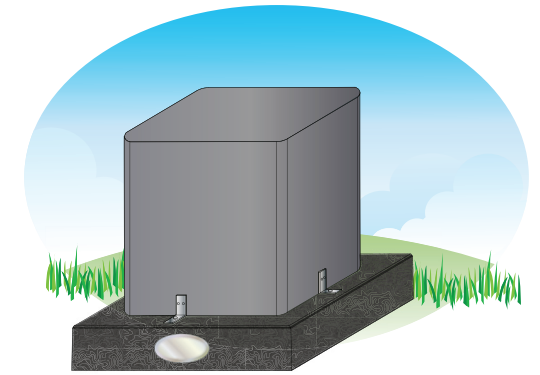

- 12 Thread the bolt back into the fastener to secure it in place. By leaving the bolt in place you keep the fastener pulled tight to the bottom of the MESA.
- 13 Repeat for each of the other three holes.
- 14 Attach each clip to the condensing unit using (2) #14 x 3/4" S.S. self-tapping screws.

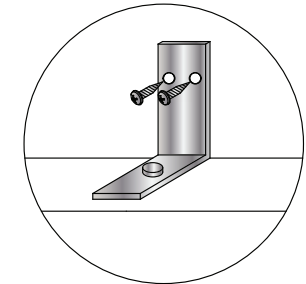

- 15 The hole in the side of each MESA is for the building inspector to view your anchor installation. The cover plate snaps into the hole and should be left loose until the installation is inspected. You or the home owner can easily attach them afterward.

# Summary of Engineering Analyses of MESA Modular HVAC Equipment Pad System



This sheet summarizes the results of engineering analyses of the MESA Modular HVAC Equipment Pad system. The engineering analyses performed by McCormick Stevenson Corp. (MCCST) find that:

1. **The MESA pad will pass the AC100 Concentrated Load Test with a maximum load of 500 lbs.** MCCST analyzed the MESA product per the Concentrated Load Test requirements of ICC-Evaluation Service document AC100 "Acceptance Criteria for Air-Conditioning Equipment Pads". The results of this analysis show that the MESA product complies with the requirements of this Concentrated Load Test.
2. **The MESA pad will pass the AC100 Creep Test with a maximum load of 125 lbs per loading disc.** MCCST analyzed the MESA product per the Creep Test requirements of ICC-Evaluation Service document AC100 "Acceptance Criteria for Air-Conditioning Equipment Pads". The results of this analysis show that the MESA product complies with the requirements of this Creep Test.
3. **The maximum allowable condensing unit weight to be supported by the MESA product is 500 lbs.** The MESA system was designed to be used with units from multiple manufacturers. While most standard units are acceptable, they must conform to the requirements listed in the MCCST report referenced below.
4. **The MESA product will sustain 150 mph wind loading without failure.** Analyzed using 150 mph wind loading in Exposure Category "C", the MESA HVAC Equipment Pad assembly complies with Chapter 16 of the 2007 Florida Building Code with 2009 Supplement. The MESA HVAC Equipment Pad is exempt from the requirements of Section 1626 of the Florida Building Code and, therefore, does not require impact testing for wind-borne debris in a high-velocity hurricane zone.
5. **The ground anchor will sustain 150 mph wind loading without failure.** When installed per the attached installation instructions, in soils consisting of loose to medium dense fine sands or firm clayey soils, the ground anchor will sustain 150 mph wind loading without failure. Soft clays and mucky (organic) soils are not considered acceptable for this application.
6. **The concrete anchor will sustain 150 mph wind loading without failure.** When installed per the attached installation instructions, over soils consisting of loose to medium dense fine sands or firm clayey soils, a concrete pad with the 1/2" stainless steel Powerstud expansion anchor will sustain 150 mph wind loading without failure. Soft clays and mucky (organic) soils are not considered acceptable for this application. The concrete pad must be large enough to obtain three inches minimum embedment of the expansion anchor and prevent any overhang of the MESA product.
7. **The AVK ARS4-420 threaded inserts will sustain 150 mph wind loading without failure.** When installed per the attached installation instructions, the AVK inserts will hold the condensing unit to the MESA product during 150 mph wind loading.
8. **The MESA pad material is appropriate for the intended use, if installed according to the attached instructions.**

For details relating to the analyses, please contact MESA Modular Systems at (727)798-7701.

Attachments: MESA Installation Instructions Earth Anchor System (dated August 2010); MESA Installation Instructions Concrete Slab Anchor System (dated August 2010); Reference: MCCST Report 10274-01, Rev. H

25400 US HWY 19 N ■ SUITE 162 ■ CLEARWATER, FL 33763 ■  
727.735.9633 ■ 727.736.8553  
[mccormickstevenson.com](http://mccormickstevenson.com)  
Florida Certificate of Authorization 28223

Mike Krawczyk, P.E. - Florida P.E. 51998