

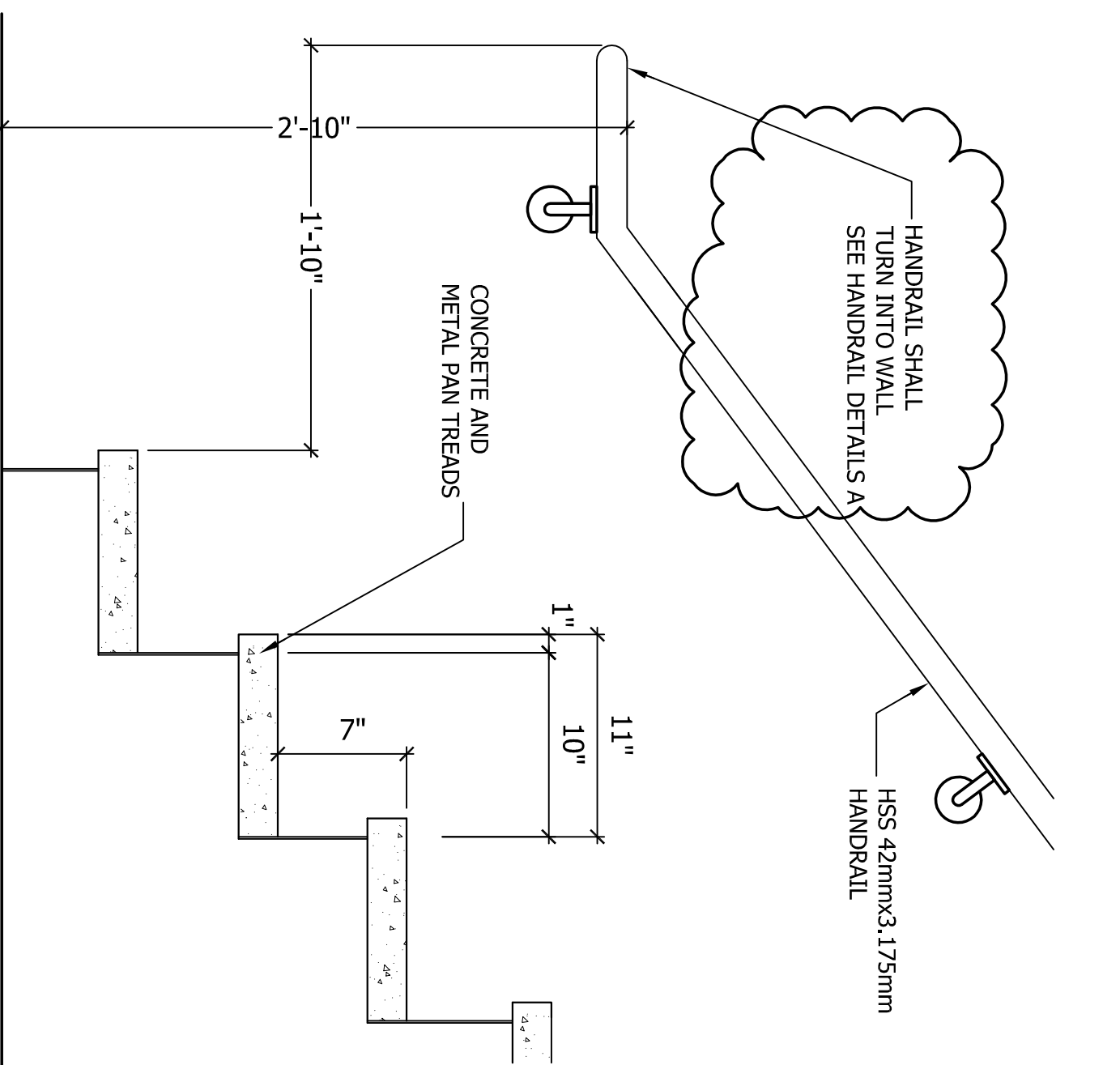

No.	DATE	ISSUED / REVISED
1	17FEB15	PERMITTING
2	11NOV15	PERMIT REV. / A
3	18FEB16	PERMIT REV. / A
4	11MAR16	PERMIT REV. / A

ALL DRAWING INFORMATION, MATERIAL, CONSTRUCTION, PERMITTING, IS THE SOLE PROPERTY OF CASTELLANOS DESIGN STUDIO, LLC. AND MAY NOT BE REPRODUCED OR TRANSMITTED IN ANY FORM OR BY ANY MEANS, ELECTRONIC, MECHANICAL, PHOTOCOPYING, RECORDING, OR BY ANY INFORMATION STORAGE AND RETRIEVAL SYSTEM, WITHOUT THE WRITTEN PERMISSION OF CASTELLANOS DESIGN STUDIO, LLC. THE USER SHALL INDEMNIFY AND HOLD CASTELLANOS DESIGN STUDIO, LLC HARMLESS FROM AND AGAINST ALL CLAIMS, DAMAGES, LOSSES AND EXPENSES, INCLUDING REASONABLE ATTORNEY'S FEES, ARISING FROM OR OUT OF THE USER'S USE OF THE DRAWING. THE USER SHALL INDEMNIFY AND HOLD CASTELLANOS DESIGN STUDIO, LLC HARMLESS FROM AND AGAINST ALL CLAIMS, DAMAGES, LOSSES AND EXPENSES, INCLUDING REASONABLE ATTORNEY'S FEES, ARISING FROM OR OUT OF THE USER'S USE OF THE DRAWING. THE USER SHALL INDEMNIFY AND HOLD CASTELLANOS DESIGN STUDIO, LLC HARMLESS FROM AND AGAINST ALL CLAIMS, DAMAGES, LOSSES AND EXPENSES, INCLUDING REASONABLE ATTORNEY'S FEES, ARISING FROM OR OUT OF THE USER'S USE OF THE DRAWING.

SEAL :

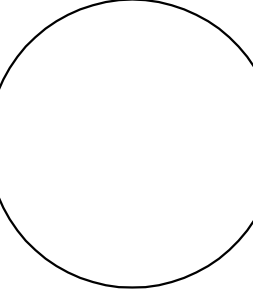

**1** STAIR ELEVATION (INTERIOR)  
SCALE : 1/4" = 1'-0"

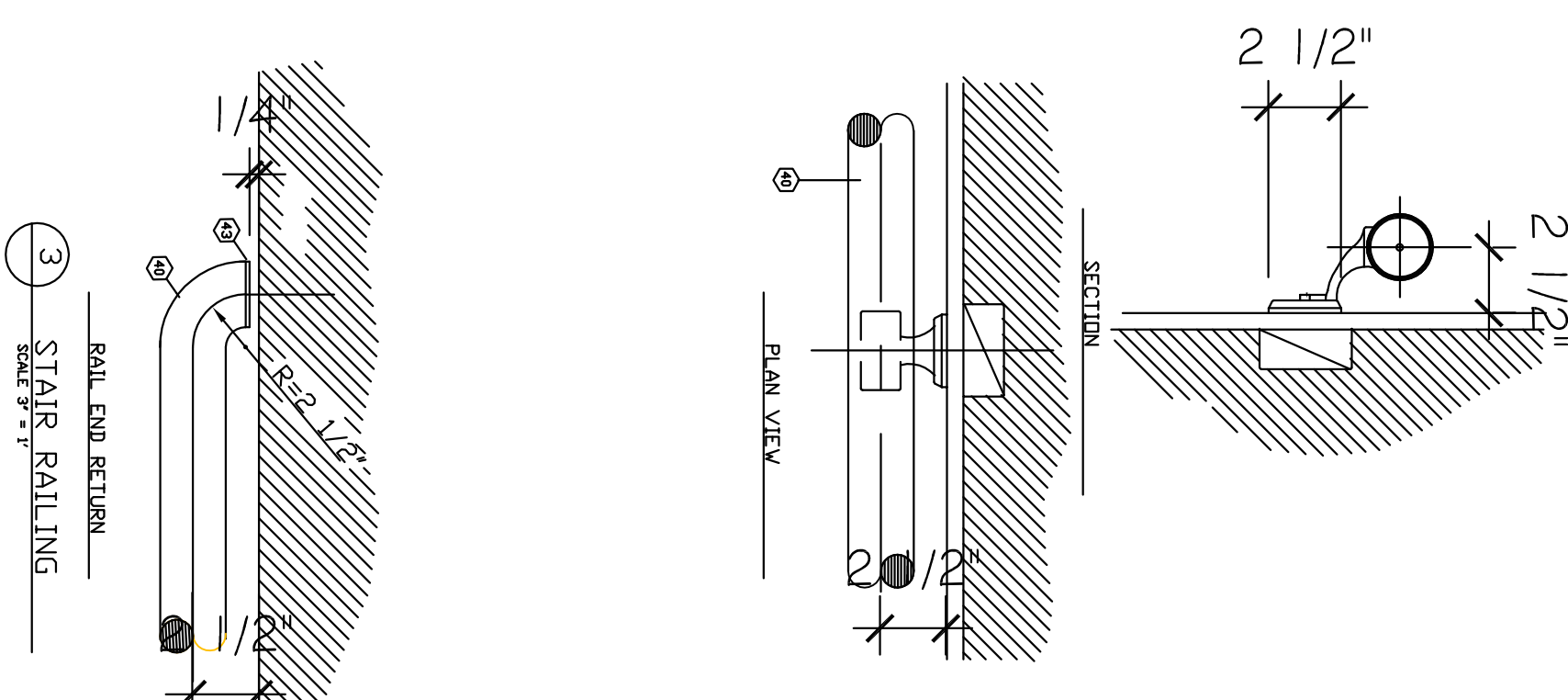

**A** HANDRAIL DETAILS (INTERIOR)  
SCALE : 3" = 1'-0"

- STAIR NOTES
1. HANDRAILS
  2. HANDBAILS SHALL BE 48" MAXIMUM SIZE
  3. HANDRAILS SHALL BE 4" ROUNDED
  4. HANDRAILS SHALL BE 4" ROUNDED
  5. HANDRAILS SHALL BE 4" ROUNDED
  6. HANDRAILS SHALL BE 4" ROUNDED
  7. HANDRAILS SHALL BE 4" ROUNDED
  8. HANDRAILS SHALL BE 4" ROUNDED
  9. HANDRAILS SHALL BE 4" ROUNDED
  10. HANDRAILS SHALL BE 4" ROUNDED
  11. HANDRAILS SHALL BE 4" ROUNDED
  12. HANDRAILS SHALL BE 4" ROUNDED

1 Hour Fire-Rated Construction		
Wt. 7		<b>U of C</b> 10-27-84
Wt. 7		UL Des U305, U314

NOTE: PROVIDE 1 HOUR RATING AT CEILING AND PENETRATION TO EXHAUST FANS AND MECHANICAL COMPONENTS AS PER FMC 607

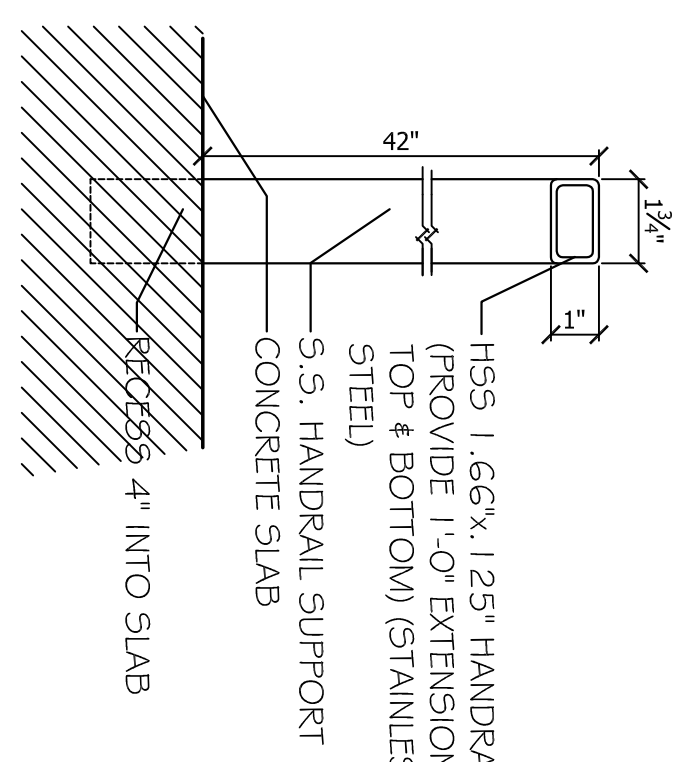

**B** HANDRAIL DETAILS (EXTERIOR)  
SCALE : 3" = 1'-0"

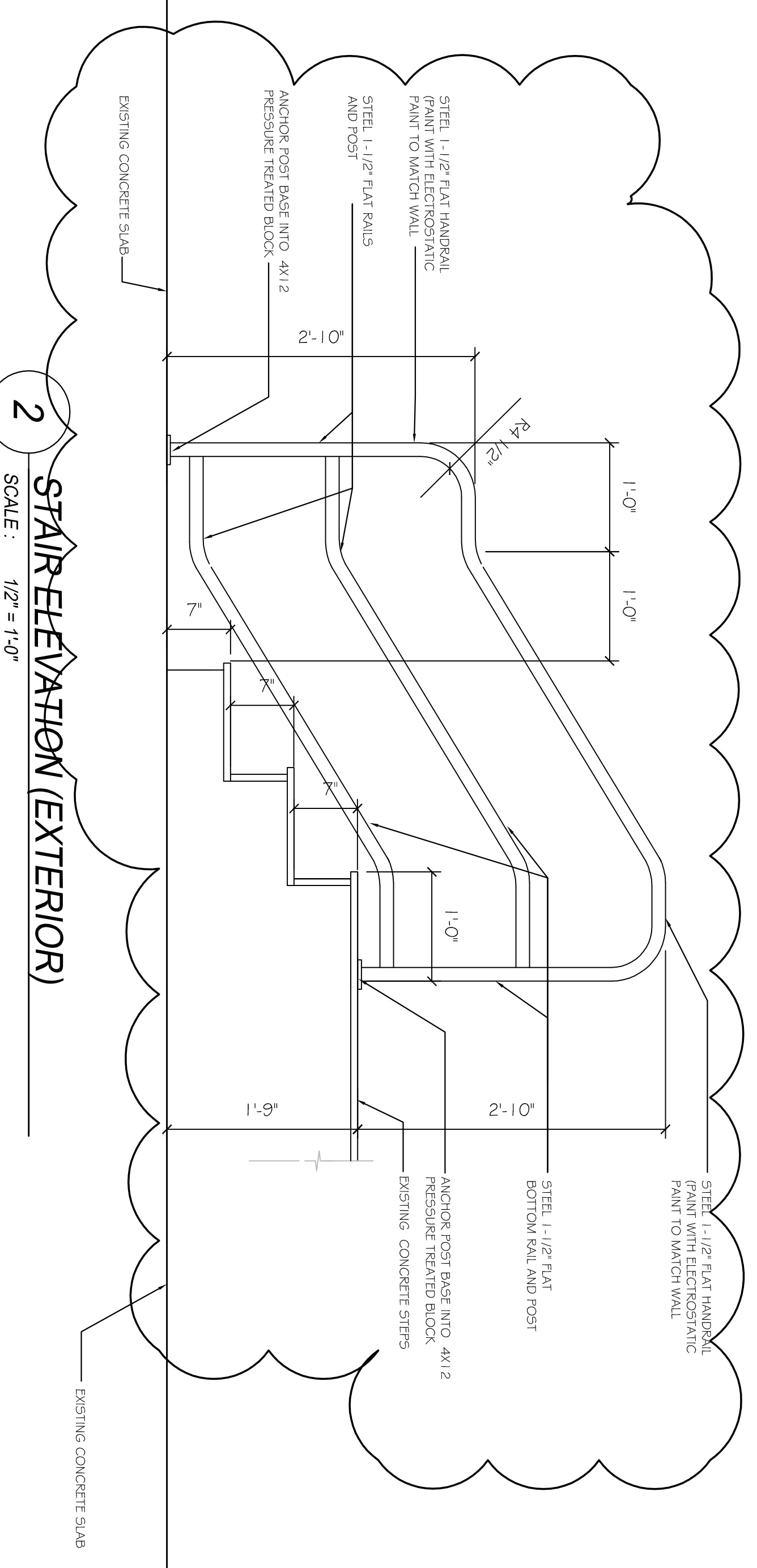

**2** STAIR ELEVATION (EXTERIOR)  
SCALE : 1/2" = 1'-0"