



[DBPR HOME](#) | [ABOUT DBPR](#) | [DBPR DIVISIONS](#) | [CONTACT DBPR](#)

[BCIS Home](#) | [Log Out](#) | [User Registration](#) | [Hot Topics](#) | [Submit Surcharge](#) | [Stats & Facts](#) | [Publications](#) | [Contact Us](#) | [BCIS Site Map](#) | [Links](#) | [Search](#)



**Florida Building Codes**

**USER:** Joe Bigelow, Department of Business & Professional Regulation, DBPR Personnel

[Binding Interpretations Menu](#) > [Petition Search](#) > [Petition List](#) > **Petition Detail**

OFFICE OF THE SECRETARY

Petition # 172

Do you have a Local Board of Appeals Yes  
 If Yes, have they rendered a decision on this issue Yes

Date	Attached File
02/17/2019	<a href="#">Pet_ID_172_FNLOrder_Building_Board_of_Adjsutments_and_Appeals_Application_LMS.pdf</a>

County Collier  
 Jurisdiction County of Collier

Building Official Johnathan Walsh  
 Address/Phone/Email 2800 North Horseshoe Drive  
 Naples, FL 34104  
 (239) 252-2490  
 Jonathan.Walsh@colliercountyfl.gov

Petitioner Name reative World Schools Three Oaks LLC  
 Address/Phone/Email 25110 Bernwood Drive  
 Unit 104  
 Bonita Springs, FL 34135  
 (239) 947-6177  
 marianne@creativeworldschool.com

Petitioner Representative's Name Larry M Schneider  
 Address/Phone/Email 4905 Midtown Lane  
 Suite 2313  
 Palm Beach Gardens, FL 33418  
 (561) 799-6942  
 Larry@LMSarch.net

Building Code Version 2017  
 Sub Code Building  
 Chapter & Topic Chapter 11 - Accessibility[Reserved]  
 Section 604.8.1.6

If permitted, date of permit application

Enter explanation of how the Petitioner's substantial interests are being affected by the local interpretation of the Florida Building Code

This interpretation is not consistent with other jurisdictions in which the same design has been accepted and approved by that jurisdiction. Please see attached Certificates of Occupancy that have been issued approved the design in question.

Furthermore - Within our classrooms sinks are strategically located within the classroom, right outside the toilet room. This specific location allows for teachers to assist children with their hand-washing and ensure that the proper steps are taken, as toddlers and young preschoolers need assistance with pumping soap, washing thoroughly, and turning the water on and off. Our teachers are able to offer this assistance while still maintaining the required supervision of the rest of the students. If sinks were placed inside the toilet rooms, they would be a tempting source of fun, or be bypassed completely when children are in a hurry to return to an activity. Additionally, if the sinks were located within the toilet room, it would lengthen the amount of time the room is occupied by an individual child. With our room layout, we are able to have one child using the toilet room while two others complete the hand-washing process. We are very mindful that when children are toilet training and learning these important skills, every moment counts. Most importantly, the safety and supervision of our children in a busy classroom is essential. We know that if teachers had to keep stepping into the toilet room, it would create a potential supervision issue for the rest of the children. Our toilet room design is strategic to give every child access, while maintaining the supervision that young children need as they are developing early self-help skills.

Dr. Marianne Whitehouse, CEO  
 Creative World School Franchising  
 25110 Bernwood Court Suite 104 Bonita Springs, FL 34135

Date	Attached File
02/17/2019	<a href="#">Pet ID 172 Interest Certificate of Occupancy Creative World School 6 27 16 with Innovating Minds name on cert .pdf</a>
02/17/2019	<a href="#">Pet ID 172 Interest Certificate of Occupancy 867234 3490 OAKSTEAD BLVD.PDF</a>
02/17/2019	<a href="#">Pet ID 172 Interest Certificate of Completion CWS Tampa Palms.pdf</a>
02/17/2019	<a href="#">Pet ID 172 Interest City of St. Cloud Certificate of Occupancy.pdf</a>
02/17/2019	<a href="#">Pet ID 172 Interest CO Creative World CWS Oviedo.pdf</a>
02/17/2019	<a href="#">Pet ID 172 Interest Gateway, Ft. Myers - CO.pdf</a>

Enter statement of the interpretation given to provisions of the Florida Building Code by the local building official and the manner in which the interpretation was rendered  
 (If information is entered, it must be exactly as it appears in the hardcopy)

Comments From The Plans Reviewer - Gentleman, Advisory 604.8.1.6 Lavatory and 604.8.1.7 Water Closet. Florida law, section 553.504(5), F.S., stipulates that "...required bathing rooms and toilet rooms in new construction shall be designed and constructed..." with an accessible lavatory in the wheelchair accessible compartment and the water closet located in a corner diagonal to the door. The ADA Standards for Accessible Design and therefore this code require wheelchair accessible compartments in new construction and in alterations of existing buildings to have self closing doors. While the Florida lavatory requirement and water closet placement apply only to new construction, they are desirable for all wheelchair accessible compartments and should be considered where feasible.

Respectfully,  
 Tim Rygiel, CFM  
 Plumbing Plans Examiner and Inspector

Date	Attached File
02/17/2019	<a href="#">Pet ID 172 BGD Interp BOAA 1-31-2019 Complete packet.pdf</a>

Enter statement of the interpretation that the petitioner contends should be given to the provisions of the Florida Building Code and a statement supporting the petitioner's interpretation

Please see attached file with our response as well as a copy of the drawings for this project

Date	Attached File
02/20/2019	<a href="#">Pet ID 172 PET Interp 15098.4 A300 - FIRST FLOOR PLAN.pdf</a>
02/20/2019	<a href="#">Pet ID 172 PET Interp 15098.4 A600 - RESTROOM PLANS, ELEVATIONS, SECTIONS.pdf</a>
02/20/2019	<a href="#">Pet ID 172 PET Interp Interpretation Comments Submittal.pdf</a>

Enter local building official response by providing a statement admitting or denying the statements contained in the petition and a statement of the interpretation of the provisions of the Florida Building Code which the local jurisdiction or the local building official contends is correct, including the basis for the interpretation

No statement made, passed allowed time to make the statement submittal.

**History**

Date Paid	02/20/2019
Date Pending Building Official Response	02/20/2019 11:30 AM
Date Building Official Response	03/04/2019
Date Submitted to BOAF	03/04/2019
Date Accepted	03/04/2019

Time Waiver Granted   
Date Extended To

[Cancel](#) [Submit Comment](#) [View Comments](#)

[DBPR Administration Menu](#)

[Contact Us](#) :: [2601 Blair Stone Road, Tallahassee FL 32399](#) Phone: 850-487-1824

The State of Florida is an AA/EEO employer. [Copyright 2007-2013 State of Florida.](#) :: [Privacy Statement](#) :: [Accessibility Statement](#) :: [Refund Statement](#)

Under Florida law, email addresses are public records. If you do not want your e-mail address released in response to a public-records request, do not send electronic mail to this entity. Instead, contact the office by phone or by traditional mail. If you have any questions, please contact 850.487.1395. \*Pursuant to Section 455.275(1), Florida Statutes, effective October 1, 2012, licensees licensed under Chapter 455, F.S. must provide the Department with an email address if they have one. The emails provided may be used for official communication with the licensee. However email addresses are public record. If you do not wish to supply a personal address, please provide the Department with an email address which can be made available to the public. To determine if you are a licensee under Chapter 455, F.S., please click [here](#).



**BOARD OF ADJUSTMENTS & APPEALS**  
**AGENDA**

**January 31, 2019**  
**2:00 p.m.**  
**Conference Room 610**

**NOTICE:**

Persons wishing to speak on any Agenda item will receive up to three (3) minutes unless the Chairman adjusts the time. Speakers are required to fill out a "Speaker Request Form," list the topic they wish to address and hand it to the Staff member seated at the table before the meeting begins. Please wait to be recognized by the Chairman and speak into a microphone. State your name and affiliation before commenting. During the discussion, Committee Members may direct questions to the speaker.

Please silence cell phones and digital devices. There may not be a break in this meeting. Please leave the room to conduct any personal business. All parties participating in the public meeting are to observe Roberts Rules of Order and wait to be recognized by the Chairman. Please speak one at a time and into the microphone so the Hearing Reporter can record all statements being made.

- I. Call to Order - Chairman
- II. Approval of Agenda
- III. Public Speakers
- IV. Agenda Item
  - A. Interpretation of the Florida Accessibility Code advisory 604.8.1.6 Lavatory and 604.8.1.7 Water Closet
- V. Committee Member Comments
- VI. Adjourn

  
**Collier County**  
Growth Management Division  
Planning & Regulation  
Building Review

Date: 1.15.2019

**BOARD OF ADJUSTMENTS AND APPEALS**

Building Permit Number (if applicable) PRBD2018105837201

For construction/project located at 2260 OLYMPIA PARK BLVD.

Of a type 2-B building to be used for DAYCARE

Name of Owner CREATIVE WORLD SCHOOLS THREE OAKS LLC

Phone # 239-947-6177 Email: MARIANNE@CREATIVELWORLDSSCHOOL.COM

Address of Owner 25110 BERNWOOD DRIVE, UNIT 104, BONITA SPRINGS, FL 34135-7813

Name of Contractor/Developer: TBD

Phone #: \_\_\_\_\_ Email: \_\_\_\_\_

Address of Contractor/Developer: \_\_\_\_\_

\*\*\*\*(Attach plot plans, application for permit and other data if applicable)\*\*\*\*

In accordance with provisions of the Collier County Land Development Code, Section 8.05.00 entitled "Building Board of Adjustments and Appeals" adopted by the Board of County Commissioners, I hereby appeal to the Board of Adjustments and Appeals for

Interpretation of the Florida Accessibility Code advisory 604.8.1.6 Lavatory and 604.8.1.7 Water Closet.  
Our understanding is that an accessible lavatory is required in the accessible toilet compartment within a toilet room. An accessible toilet compartment is a toilet stall not a toilet room. Therefrom in the case of a single toilet room for each of the Daycare classrooms an accessible lavatory is not required within the single toilet room.

in order that I might construct the above name structure as proposed and shown on the attachments.

MARIANNE WHITEHOUSE  
Printed Name of Applicant

  
Signature of Applicant

Fee: \$250.00 payable to "Board of County Commissioners"

Meeting Date: \_\_\_\_\_

(To be established by the Staff Liaison of the Board of Adjustments and Appeals)



**Collier County  
Growth Management Division**

2800 Horseshoe Drive N.  
Naples, FL 34104  
239-252-2400

**RECEIPT OF PAYMENT**

**Receipt Number:** 2019581758  
**Transaction Number:** 2019-005032  
**Date Paid:** 01/17/2019  
**Amount Due:** \$250.00

<b>Payment Details:</b>	<b><u>Payment Method</u></b>	<b><u>Amount Paid</u></b>	<b><u>Check Number</u></b>
	Check	\$250.00	16980

**Amount Paid:** \$250.00  
**Change / Overage:** \$0.00  
**Contact:** C&K Architechts | Interiors Inc. Michael Patterson  
4221 Boy Scout Blvd. STE150  
Tampa, FL 33607

**FEE DETAILS:**

<b><u>Fee Description</u></b>	<b><u>Reference Number</u></b>	<b><u>Original Fee</u></b>	<b><u>Amount Paid</u></b>	<b><u>GL Account</u></b>
Building Board of Adjustments and Appeals	PRBD20181058372	\$250.00	\$250.00	113-138900-322110-000000

**Cashier Name:** LeaDerence  
**Batch Number:** 7960  
**Entered By:** RenaldPaul

## **Building Board of Adjustments and Appeals Application and Backup Material**

In accordance with provisions of the Collier County Land Development Code, Section 8.05.00 entitled "Building Board of Adjustments and Appeals" adopted by the Board of County Commissioners, I hereby appeal to the Board of Adjustments and Appeals for the following opinion of the building department as it specifically relates to the requirements of the Florida Accessibility Code for Building Construction - 2012 [FACBC].

**Question** - Does Section 604.8.1.7 of the FACBC mandate the requirement to provide a lavatory within a single user toilet room as it specifically relates to the Creative World School Project in which there are single user toilet rooms serving the following rooms/spaces that are designed only with a toilet and the lavatory is located outside of the toilet room -

- ▶ Toddlers Daycare
- ▶ Twos Daycare
- ▶ Threes Daycare
- ▶ Fours Daycare

**Response** - Our answer is no, the FACBC does not require the lavatory to be within the single user toilet room.

**Informational Backup** - Pursuant to the Florida State Statutes and section 553.775 Interpretations (1) which states that it is the intent of the Legislature that the Florida Building Code and the Florida Accessibility Code for Building Construction be interpreted by building officials, local enforcement agencies, and the commission in a manner that protects the public safety, health, and welfare at the most reasonable cost to the consumer by ensuring uniform interpretations throughout the state and by providing processes for resolving disputes regarding interpretations of the Florida Building Code and the Florida Accessibility Code for Building Construction which are just and expeditious; we are requesting the Building Board of Adjustments and Appeals as it relates to an interpretation of the following accessibility code opinion by the plan reviewer as it relates to toilet rooms -

The question is does Section 604.8.1.7 of the FACBC mandate the requirement to provide a lavatory within a single user toilet room as it specifically relates to the Creative World School Project in which there are single user toilet rooms serving the following rooms/spaces that are designed only with a toilet and the lavatory is located outside of the toilet room -

- Toddlers Daycare
- Twos Daycare
- Threes Daycare
- Fours Daycare<sup>1</sup>

---

<sup>1</sup>The number relates to the age of the children within the room

## **Building Board of Adjustments and Appeals Application and Backup Material**

**Project Comments** - The architectural design firm received a plan review comment from Collier County requiring lavatories inside the toilet room within the daycare classrooms of this project. The current layout has one toilet in each toilet room within the daycare classrooms with an accessible lavatory outside of the single user toilet room. The plan reviewer cited the following sections of the FACBC - 213.2, 603 & 604.

**Comments From The Plans Reviewer** - Gentleman, Advisory 604.8.1.6 Lavatory and 604.8.1.7 Water Closet. Florida law, section 553.504(5), F.S., stipulates that "...required bathing rooms and toilet rooms in new construction shall be designed and constructed..." with an accessible lavatory in the wheelchair accessible compartment and the water closet located in a corner diagonal to the door. The ADA Standards for Accessible Design and therefore this code require wheelchair accessible compartments in new construction and in alterations of existing buildings to have self closing doors. While the Florida lavatory requirement and water closet placement apply only to new construction, they are desirable for all wheelchair accessible compartments and should be considered where feasible.

Respectfully,

Tim Rygiel, CFM  
Plumbing Plans Examiner and Inspector

**Response Comments** - Here is what the section referenced actually states - 604.8.1.6 Lavatory. In new construction, **the wheelchair accessible toilet compartment** shall contain an accessible lavatory within it, which must be at least 19 inches wide by 17 inches deep, nominal size, and wall-mounted. The lavatory shall be mounted so as not to overlap the clear floorspace areas required by section 604 for the wheelchair accessible toilet compartment and shall comply with section 606. Such lavatories shall be counted as part of the required fixture count for the building. See also section 213.3.4.

Advisory 604.8.1.6 Lavatory and 604.8.1.7 Water Closet. Florida law, section 553.504(5), F.S., stipulates that "...required bathing rooms and toilet rooms in new construction shall be designed and constructed..." with an accessible lavatory in the wheelchair accessible compartment and the water closet located in a corner diagonal to the door. The ADA Standards for Accessible Design and therefore this code require wheelchair accessible compartments in new construction and in alterations of existing buildings to have self closing doors. While the Florida lavatory requirement and water closet placement apply only to new construction, they are desirable for all wheelchair accessible compartments and should be considered where feasible.

**What The Florida State Statute States** - 553.504 (5) Notwithstanding ss. 213 and 604 of the standards, required bathing rooms and toilet rooms in new construction shall be designed and constructed in accordance with the following:



## **Building Board of Adjustments and Appeals Application and Backup Material**

- (a) **The wheelchair accessible toilet compartment must contain an accessible lavatory within it**, which must be at least 19 inches wide by 17 inches deep, nominal size, and wall-mounted. The lavatory shall be mounted so as not to overlap the clear floor space areas required by s. 604 of the standards for the wheelchair accessible toilet compartment and comply with s. 606 of the standards. Such lavatories shall be counted as part of the required fixture count for the building.
- (b) The accessible water closet within the wheelchair accessible toilet compartment must be located in the corner, diagonal to the door.

**FACBC- 2012 - 213.3 Plumbing Fixtures and Accessories.** Plumbing fixtures and accessories provided in a toilet room or bathing room required to comply with 213.2 shall comply with 213.3.

**LMS Comments** - It appears that Mr. Rygiel is reading the section regarding the requirement for an accessible lavatory within the wheelchair accessible toilet compartment to also mean that a lavatory is required within a toilet room. As you can see section 213.3 states that where plumbing fixtures and accessories are provided in a toilet room that they are required to be accessible pursuant to the rest of that section; however it does not mandate that a lavatory be provided within a toilet room. Florida State Statutes clearly states that the lavatory is required, under new construction, that a wheelchair accessible toilet compartment must contain an accessible lavatory within it. The toilet room in question is a single user toilet room serving the daycare rooms. It has been standard design practice that for this age group, 2, 3, and 4 year olds, within a daycare facility, that the toilet room only has a toilet in it and that the lavatory be located outside the toilet room, within the daycare room.

There is a common area accessible toilet room, with a lavatory within it for the staff. So, the question is does the FACBC - 2012 require that a lavatory be provided within a toilet room?

Pursuant to the applicable sections referenced above and the language of the Florida State Statute it is our opinion that the FACBC does not require a lavatory within a single user toilet room; but it does require a lavatory within an accessible toilet compartment in new construction.

Attached you will find copies of the floor plans of the project in question. We look forward to meeting with you to address and resolve this interpretation of the FACBC.

Thank you,

Larry M Schneider AIA

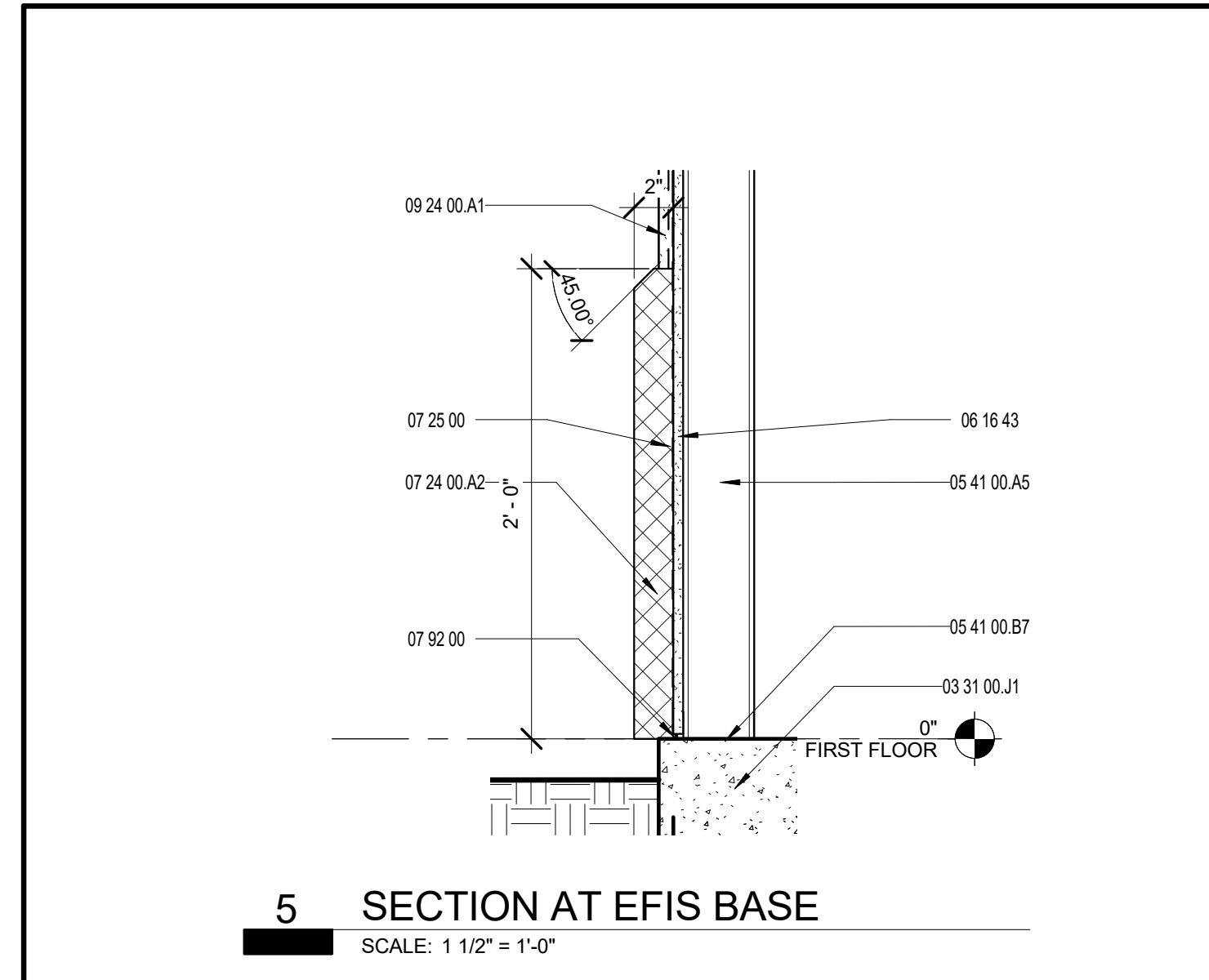

**5 SECTION AT EFIS BASE**  
SCALE: 1 1/2" = 1'-0"

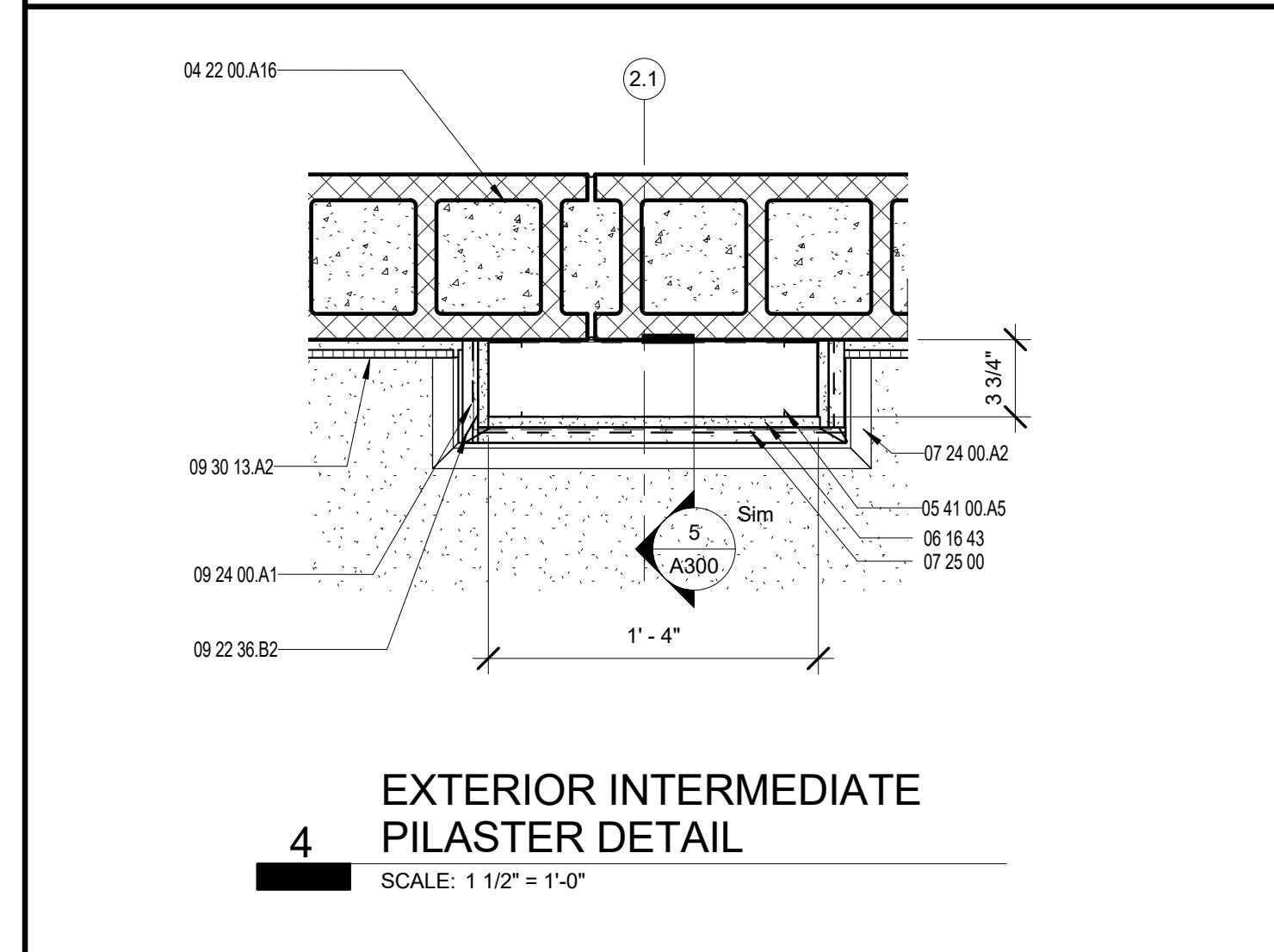

**4 EXTERIOR INTERMEDIATE PILASTER DETAIL**  
SCALE: 1 1/2" = 1'-0"

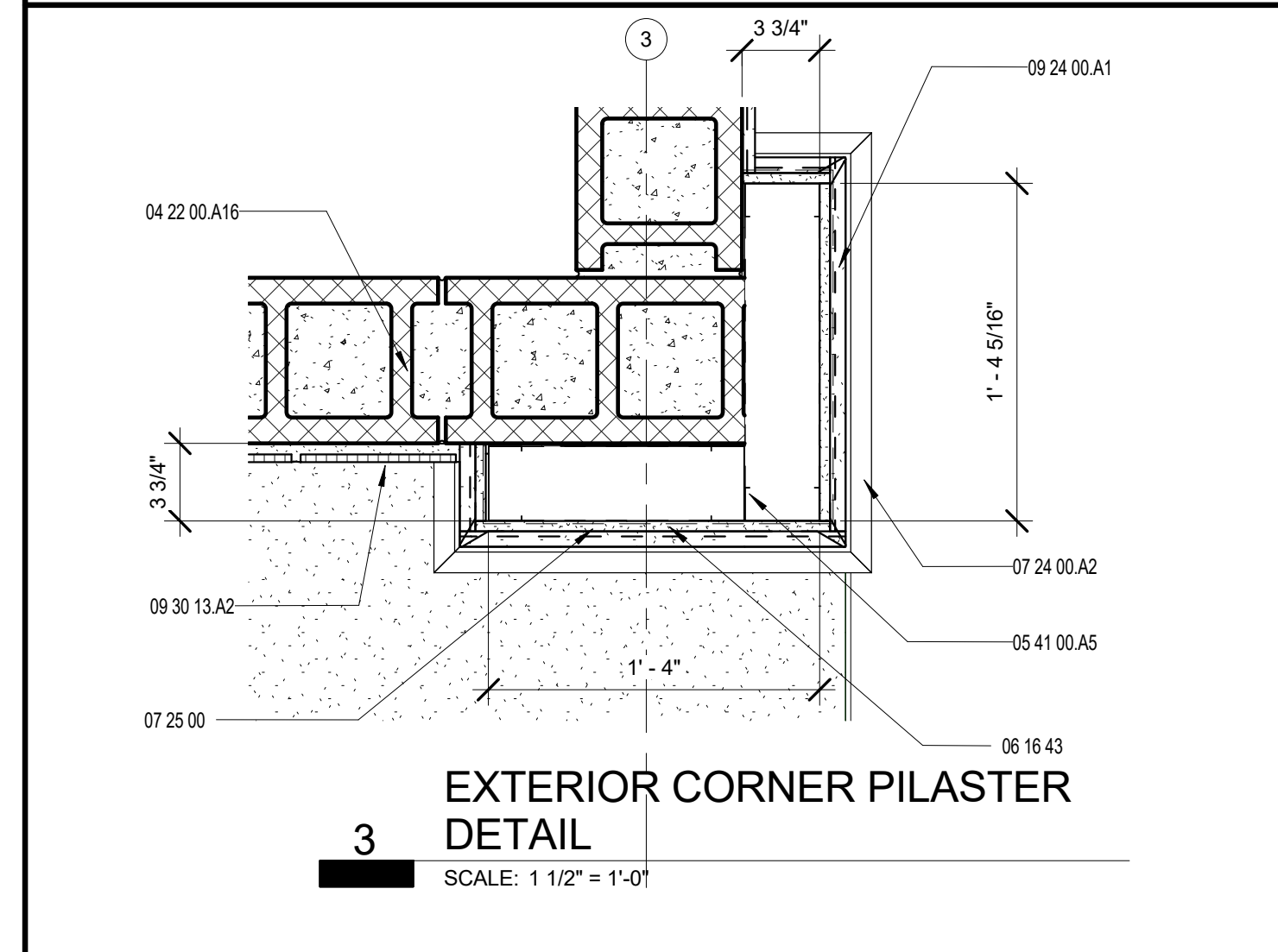

**3 EXTERIOR CORNER PILASTER DETAIL**  
SCALE: 1 1/2" = 1'-0"

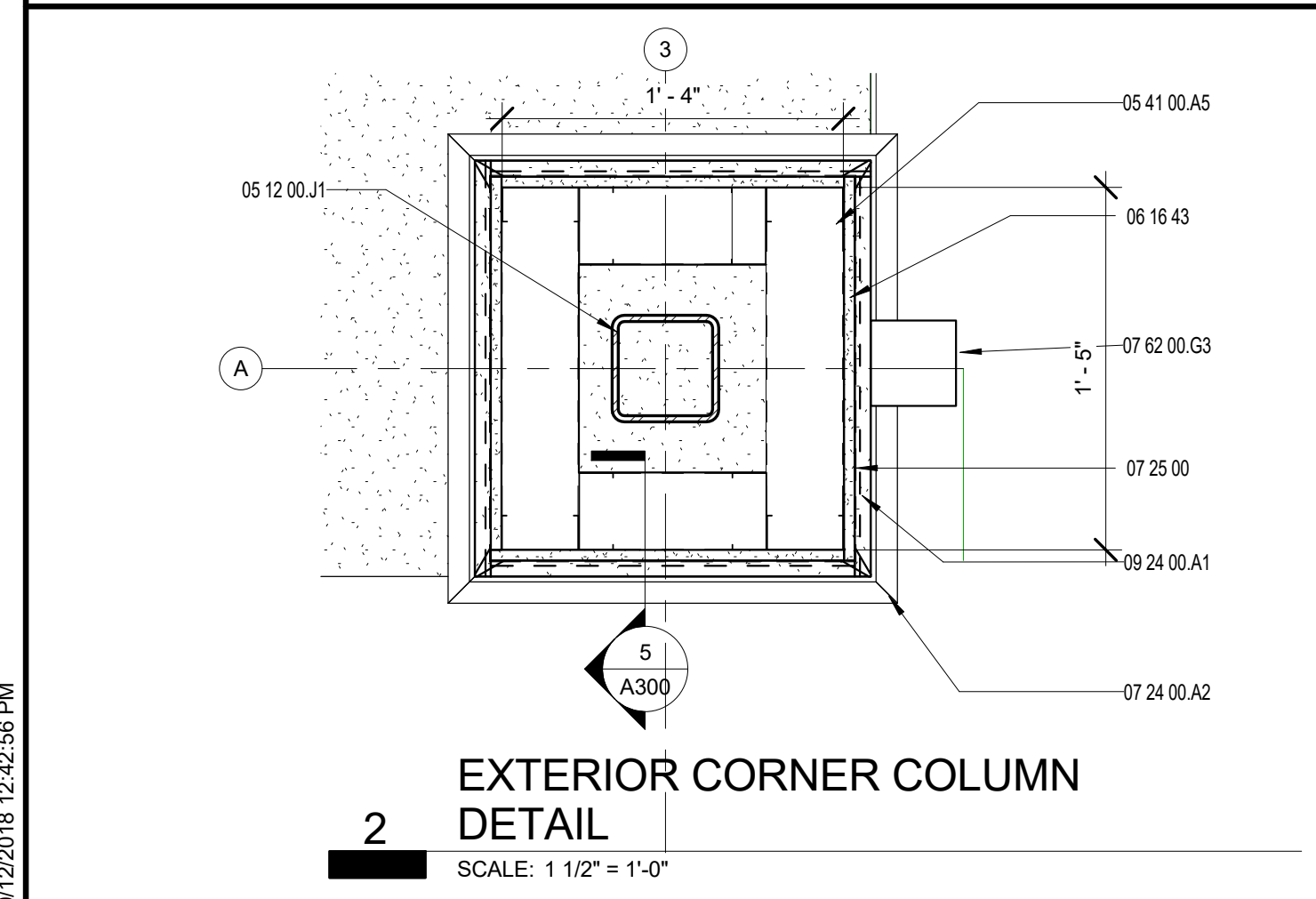

**2 EXTERIOR CORNER COLUMN DETAIL**  
SCALE: 1 1/2" = 1'-0"

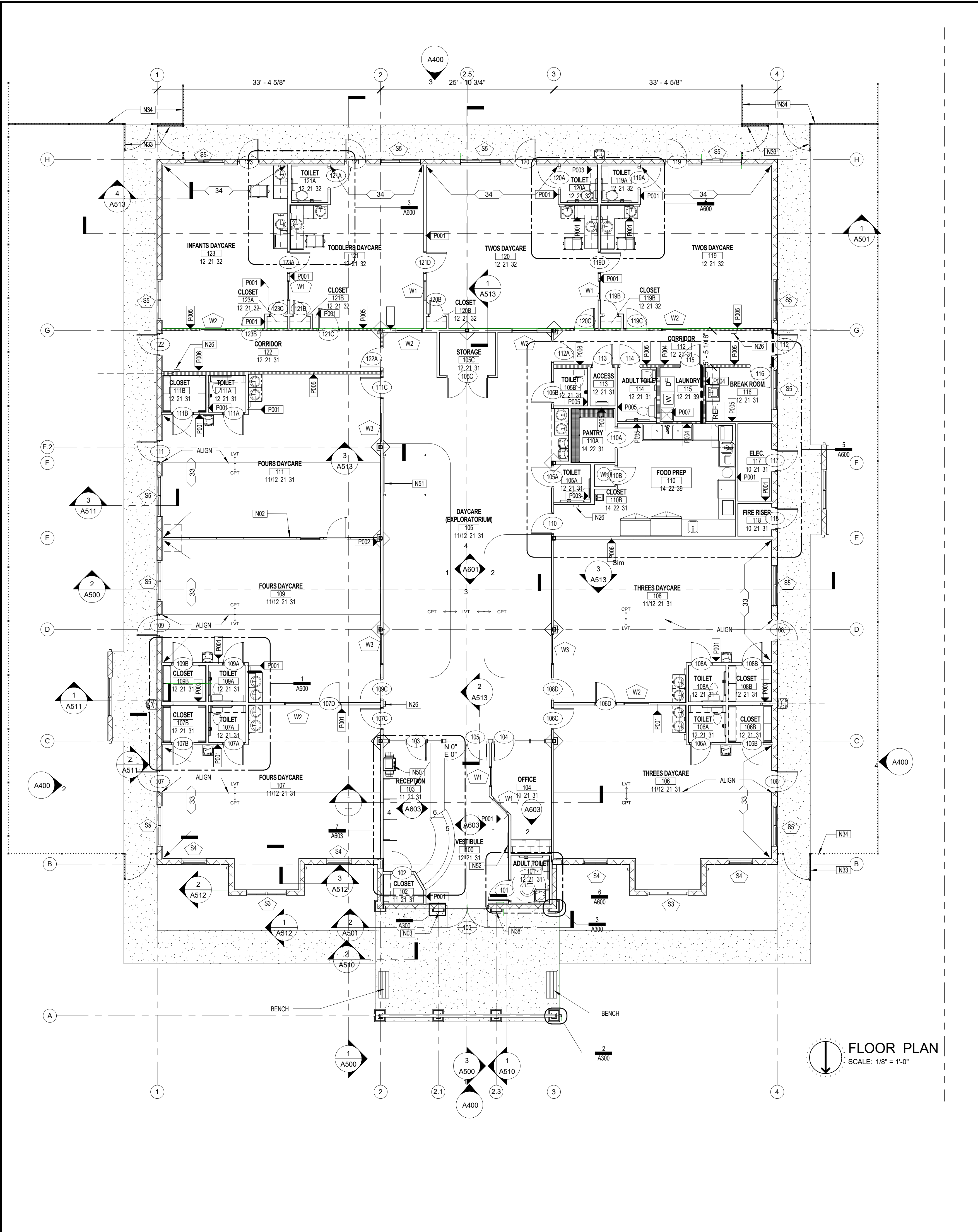

**FLOOR PLAN**  
SCALE: 1/8" = 1'-0"

**GENERAL NOTES**

- REFER TO COVER SHEET A1 FOR FLOOR AREA CALCULATIONS.
- COMPLY WITH LDC 5.05.08 F.41 SERVICE FUNCTION AREAS AND FACILITIES CONDUITS, METERS AND VENTS. CONDUITS, METERS AND VENTS AND OTHER EQUIPMENT ATTACHED TO THE BUILDING OR PROTRUDING FROM THE ROOF SHALL BE SCREENED OR PAINTED TO MATCH SURROUNDING BUILDING SURFACES. CONDUITS AND METERS CANNOT BE LOCATED ON THE PRIMARY FACADE OF THE BUILDING.
- ALL PARTITIONS TO BE TYPE P001 UNLESS NOTED OTHERWISE. REFER TO ENLARGED PLANS FOR ADDITIONAL PARTITION TYPES.
- REFER TO SHEET A320 FOR DOOR SCHEDULE, HARDWARE AND DETAILS.
- REFER TO SHEET A330 FOR WINDOW SCHEDULE AND DETAILS.
- PROVIDE BULLNOSE CORNER BEAD FOR ALL INTERIOR DRYWALL OUTSIDE CORNERS.

**SHEET NOTES**

- OPERABLE WALL PARTITION, WITH DOOR AND WINDOW. REFER TO SPECIFICATIONS.
- KNOX BOX KEY CABINET, MOUNT 48-INCHES ABOVE SLAB
- FIRE EXTINGUISHER CABINET
- 4'-0" WIDE GATE WITH PANIC HARDWARE"
- 6'-0" HIGH METAL PICKET FENCE"
- OWNER FURNISHED ACCESS CONTROL KEYPAD MOUNT 48" AFF
- OWNER FURNISHED COPIER.
- OWNER FURNISHED SMART BOARD, PROVIDE 20 GA METAL BACKING
- OWNER FURNISHED FLAT SCREEN, PROVIDE 20 GA METAL BACKING, VERIFY MOUNTING HEIGHT WITH OWNER.

**KEYNOTES**

NO.	DESCRIPTION
03 31 00 J1	4" CONCRETE SLAB (4,000 PSI) WITH 6 X 6 X W1.4 X W1.4 WWF, ON 10 MIL VAPOR BARRIER OVER TERMITRE TREATED COMPACTED FILL (TYP.)
04 22 00 A16	8" CONCRETE MASONRY UNIT WITH HORIZONTAL REINFORCING AT 16" O.C.
05 12 00 J1	STEEL TUBE - SEE STRUCTURAL
05 41 00 A5	3-5/8" METAL STUD - SEE STRUCTURAL
05 41 00 B7	CONT. STEEL TRACK
06 16 43	GYPSUM SHEATHING
07 24 00 A2	EIFS WALL BASE WITH BEVELED TOP
07 25 00	WEATHER BARRIERS
07 62 00 G3	4" X 4" RECTANGULAR RAIN LEADER
07 92 00	JOINT SEALANTS
09 22 36 B2	CEMENT PLASTER CORNER BEAD - SEE SPECIFICATIONS
09 24 00 A1	CEMENT PLASTER - SEE SPECIFICATIONS
09 30 13 A2	CERAMIC TILE

**FINISH NARRATIVE**

FINISH MARK	FINISH / MATERIAL	REMARKS
10	CONC. SEALER	-
11	CARPET TILE	INTERFACEFLOR LLC, CUBIC LINE-COLOR: AREA-4292, 52 CM X 52 CM
12	LVT	MANNINGTON, SPACIA-WOOD, COLOR:WEATHERED OAK -S5W2524, 4" X 36"
13	QUARRY TILE	CROSSVILLE, METROPOLITAN CERAMIC, COLOR 505 PLAZA GRAY, 8" X 8"
21	4" VINYL COVE BASE	JOHNSONITE, COLOR: MIDNIGHT-83
22	QUARRY TILE COVE BASE	CROSSVILLE, METROPOLITAN CERAMIC, COLOR 505 PLAZA GRAY, 8" X 8"
31	PAINT	MATCH DURON, COLOR: BLUE CHILL-7050W
32	PAINT	MATCH DURON, COLOR: ICED ORCHID-7470W
33	PAINT	MATCH DURON, COLOR: POMPEII-7055D
34	PAINT	MATCH DURON, COLOR:WILD ORCHID-7475D
35	PAINT	SHERWIN WILLIAMS COLOR:SW7007-CEILING BRIGHT WHITE
39	FRP	MARLITE COLOR:P151 LIGHT GREY, CLASS A

- INTERIOR PAINT SCHEDULE:**
- CMU SUBSTRATES: PRE-CATALYZED WATER BASED EPOXY, SEMI GLOSS FINISH.
  - METAL SUBSTRATES: WATER BASED ALKYD URETHANE, SEMI GLOSS FINISH.
  - WOOD SUBSTRATES: WATER BASED ALKYD URETHANE, SEMI GLOSS FINISH.
  - GYPSUM BOARD SUBSTRATES (ACCEPT CEILING): PRE-CATALYZED WATER BASED EPOXY, EGGSHELL FINISH.
  - GYPSUM BOARD CEILING: LAYTEX WATER BASED, FLAT FINISH.
- REFER TO SPECIFICATIONS FOR PRIMERS AND PAINT PRODUCTS.

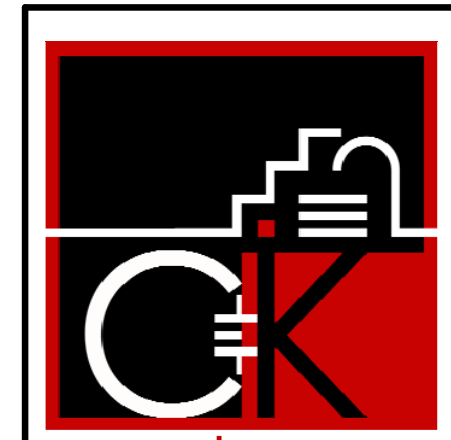

**ARCHITECTS INTERIORS, INC.**  
architects-interiors design-build services  
AACC011427

4301 Anchor Plaza Parkway, Ste 100  
Tampa, FL 33634-7525  
813.884.2000

280 West Central Avenue  
Winter Haven, FL 33880-2957  
863.577.2054

BRYAN L. KARSKY

DESCRIPTION

NO. DATE BY

CONSTRUCTION DOCUMENTS  
**FIRST FLOOR PLAN**  
DAYCARE FACILITY FOR  
**CREATIVE WORLD SCHOOL**  
VANDERBILT BEACH RD.  
NAPLES, FL

ISSUED FOR:  
PROJECT NUMBER:  
15098  
DATE:  
9.21.2018  
DRAWING NUMBER:  
**A300**

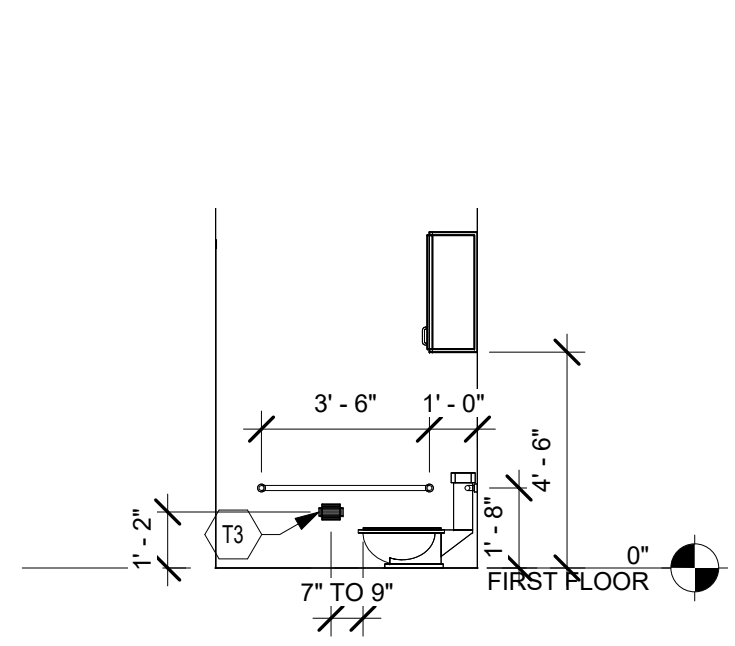

**13 TODDLER CLASSROOM TOILET - SIDE ELEVATION**  
SCALE: 1/4" = 1'-0"

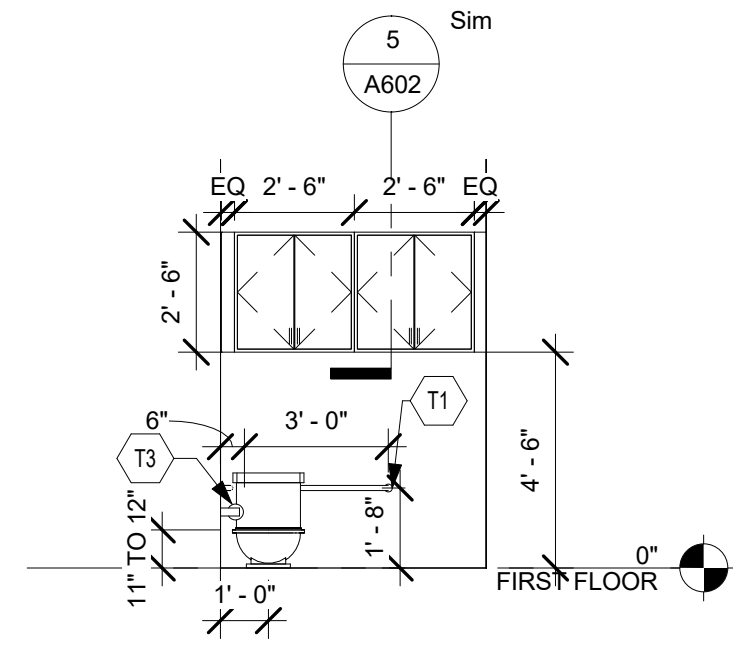

**9 TODDLER CLASSROOM TOILET - FRONT ELEVATION**  
SCALE: 1/4" = 1'-0"

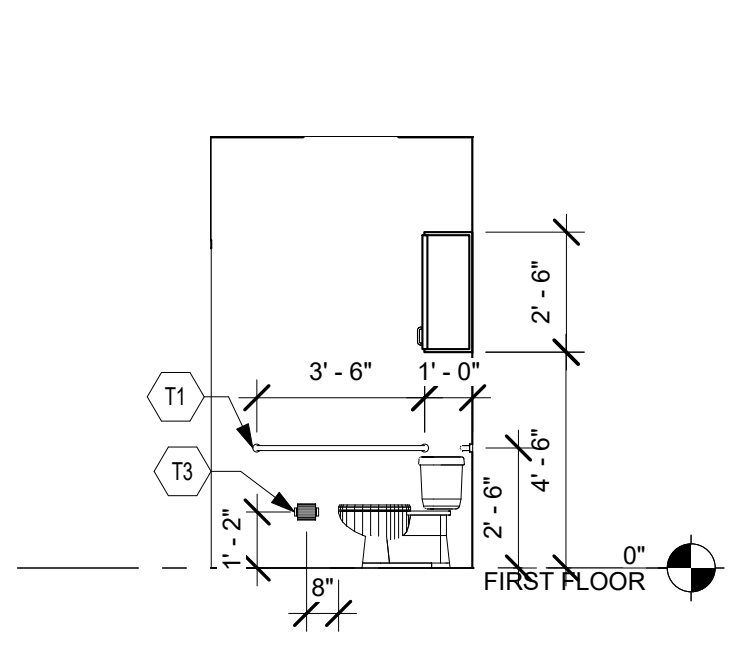

**7 CLASSROOM TOILET - SIDE ELEVATION**  
SCALE: 1/4" = 1'-0"

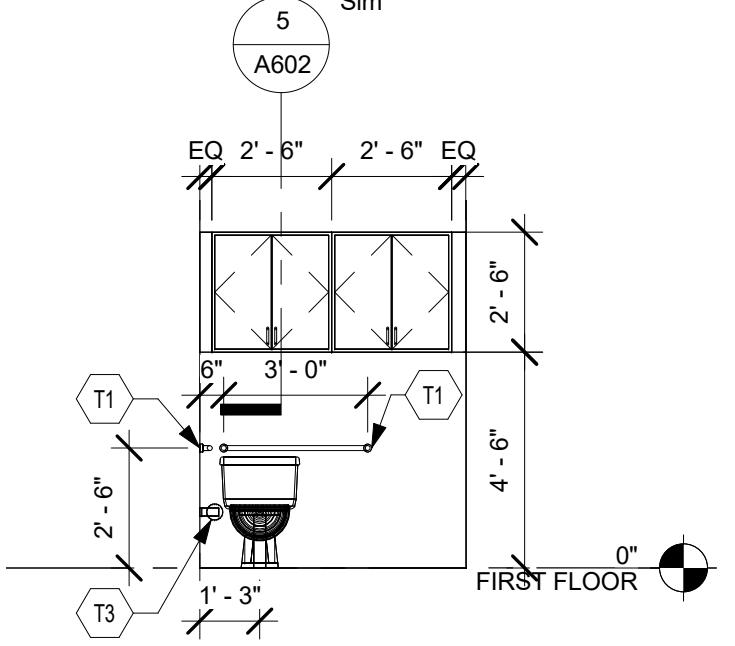

**4 CLASSROOM TOILET - FRONT ELEVATION**  
SCALE: 1/4" = 1'-0"

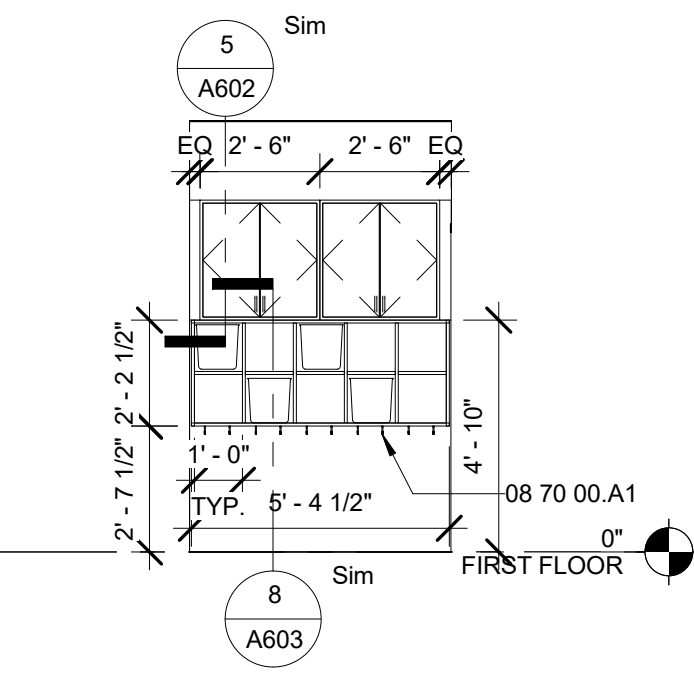

**16 STORAGE CUBBIES ELEVATION**  
SCALE: 1/4" = 1'-0"

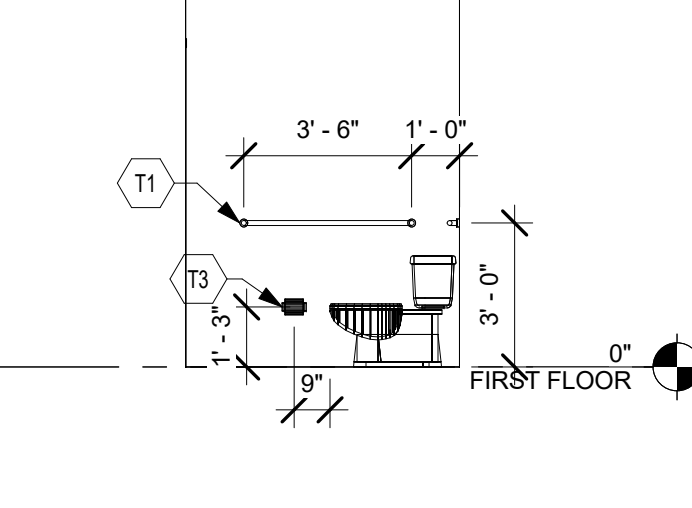

**12 ADULT TOILET-101 SIDE ELEVATION**  
SCALE: 1/4" = 1'-0"

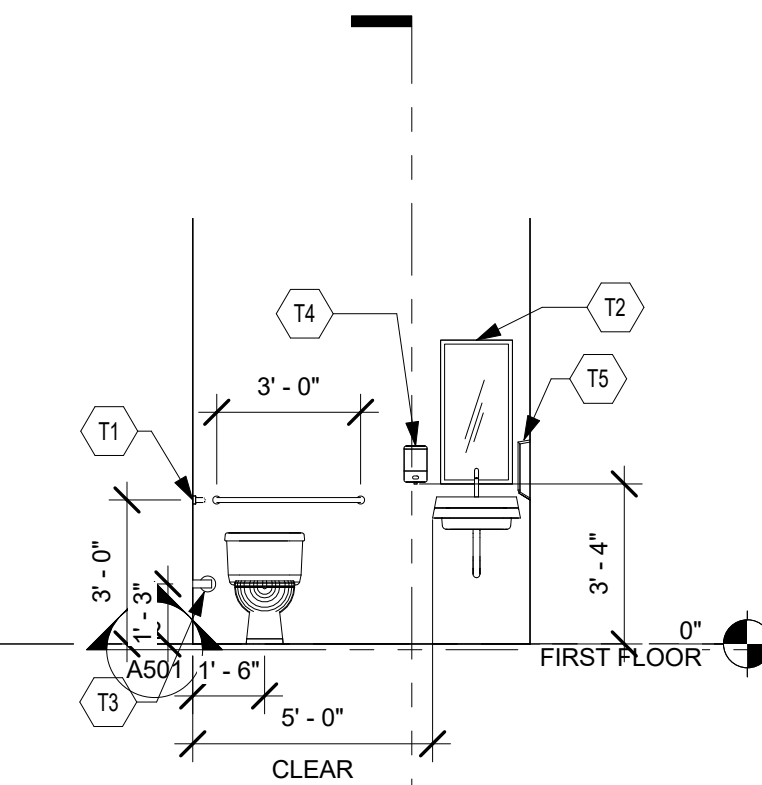

**8 ADULT TOILET-101 - FRONT ELEVATION**  
SCALE: 1/4" = 1'-0"

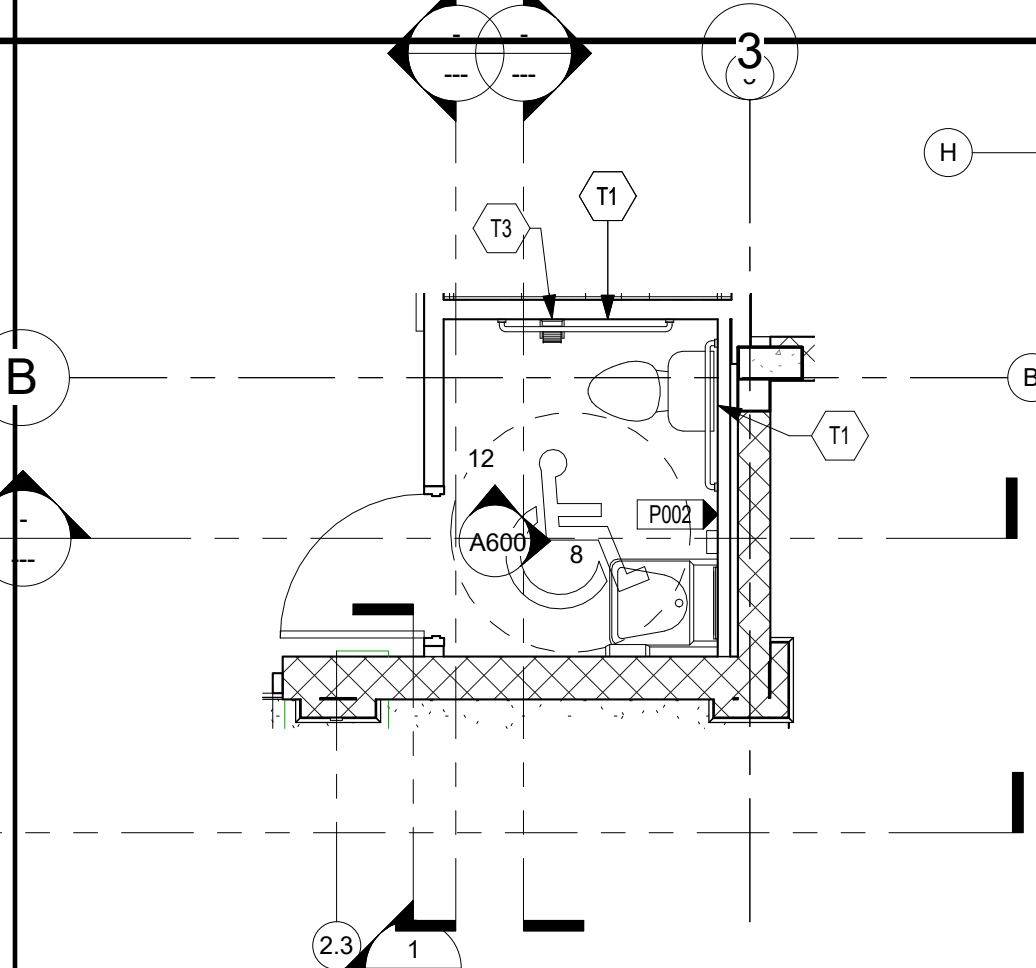

**6 ENLARGED PLAN - ADULT TOILET 101**  
SCALE: 1/4" = 1'-0"

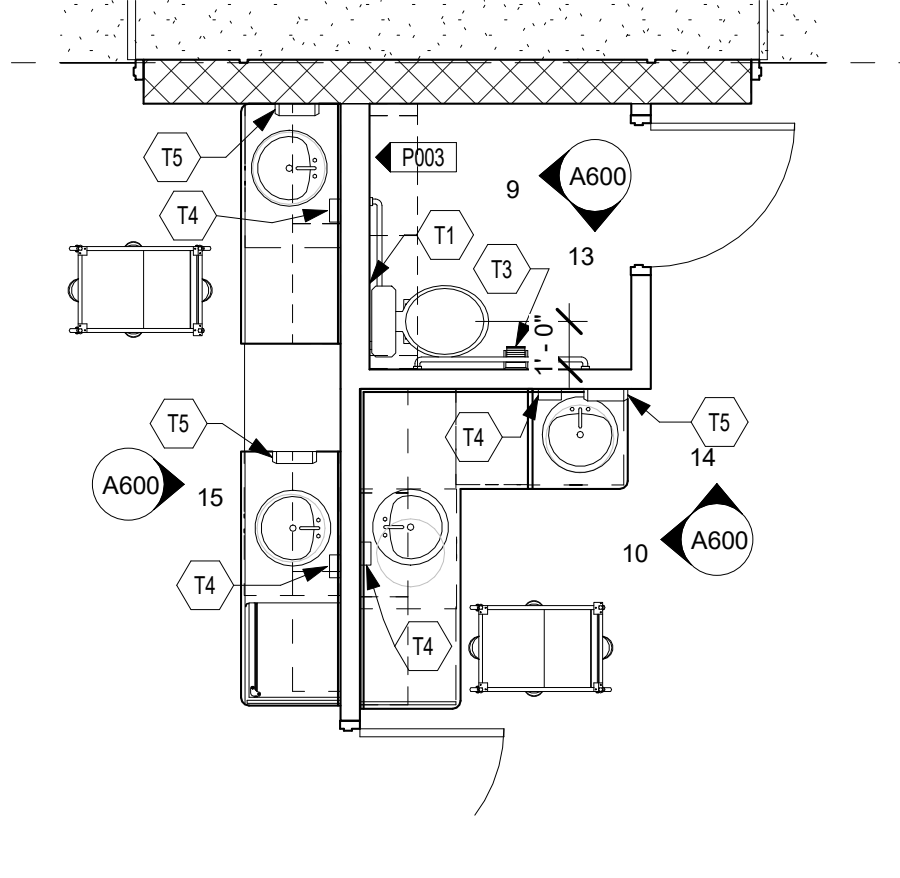

**3 ENLARGED PLAN - INFANTS/TODDLERS TOILET**  
SCALE: 1/4" = 1'-0"

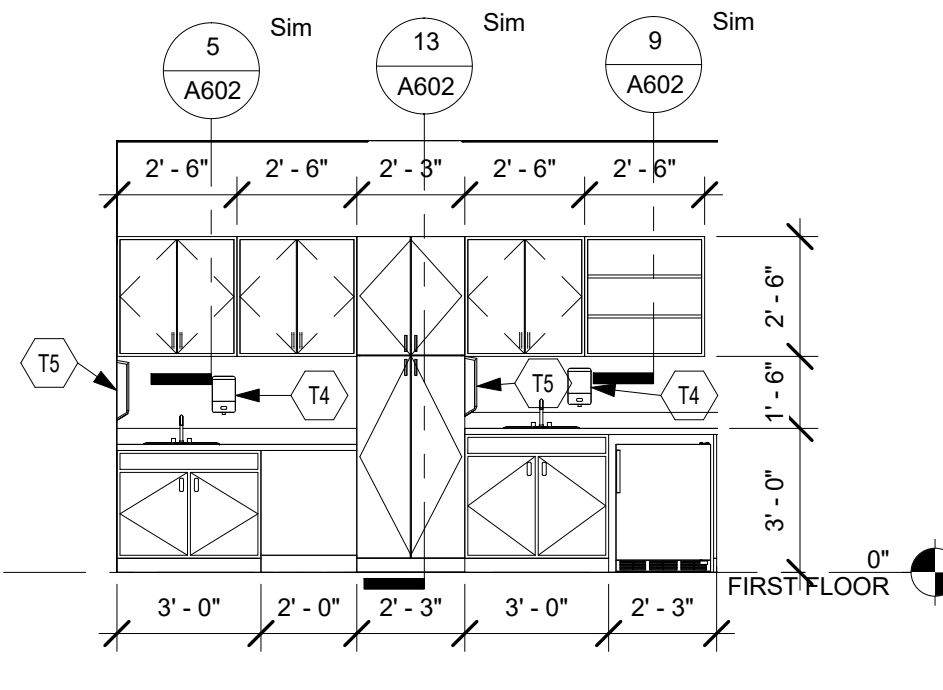

**15 INFANTS CLASSROOM MILLWORK ELEVATION**  
SCALE: 1/4" = 1'-0"

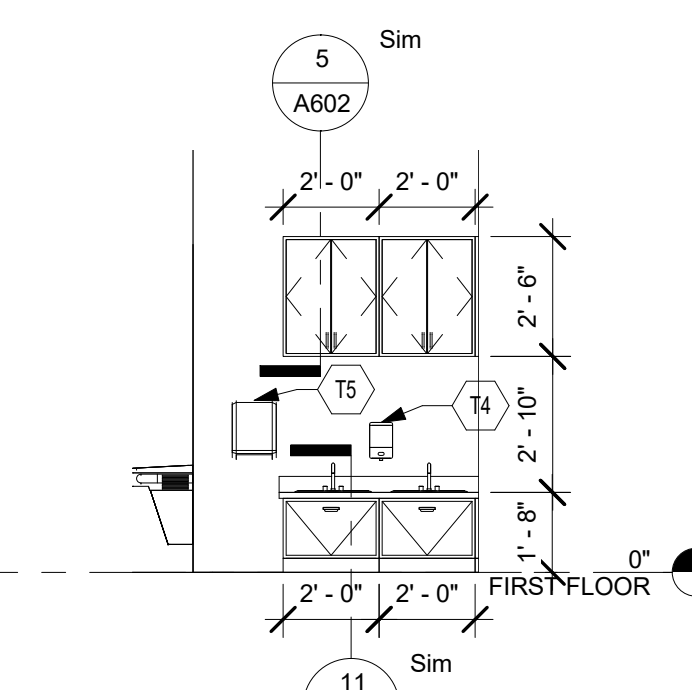

**11 TYPICAL CLASSROOM - MILLWORK ELEVATION FRONT**  
SCALE: 1/4" = 1'-0"

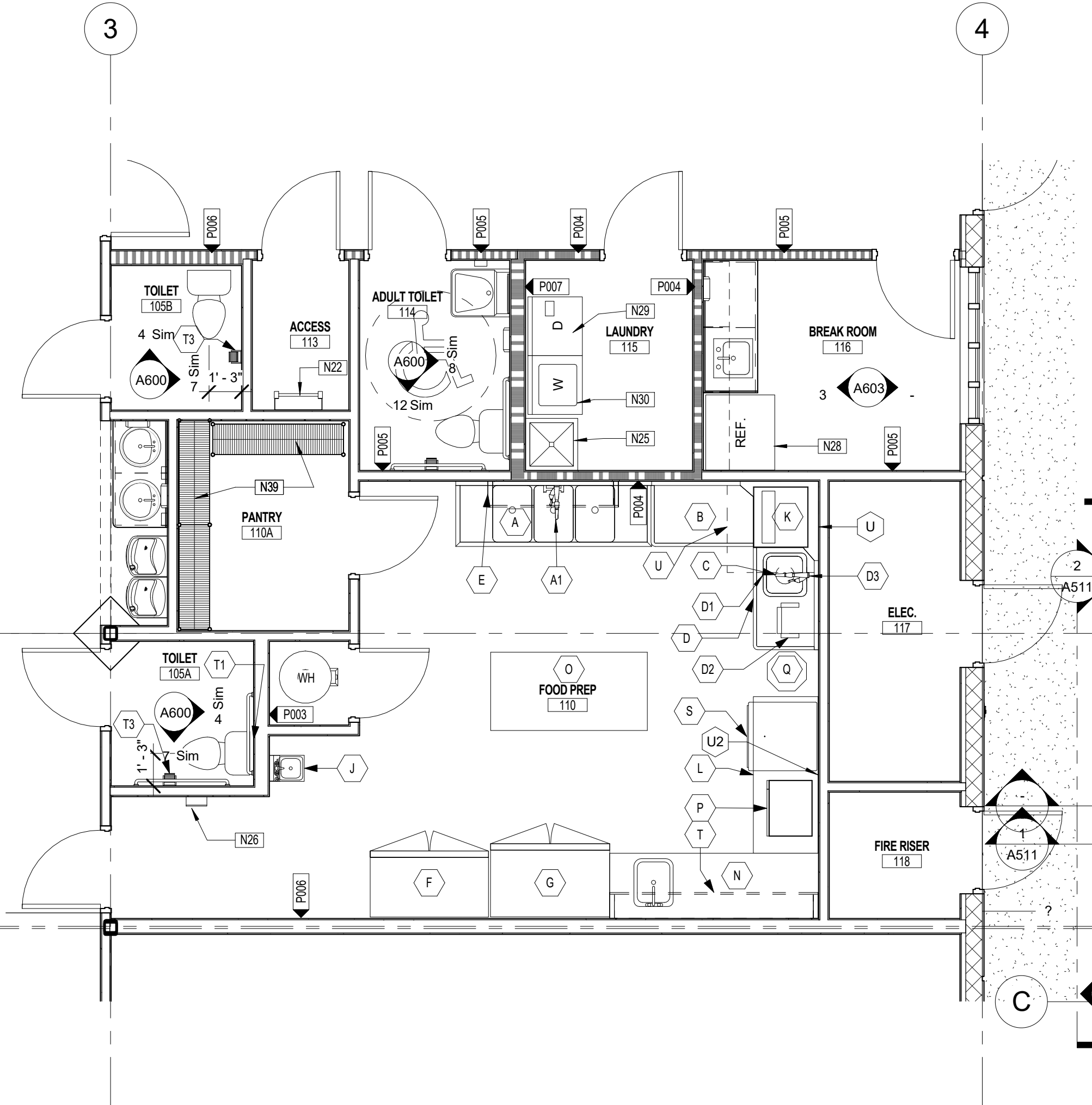

**5 ENLARGED PLAN FOOD PREP, LOUNGE AND TOILET**  
SCALE: 1/4" = 1'-0"

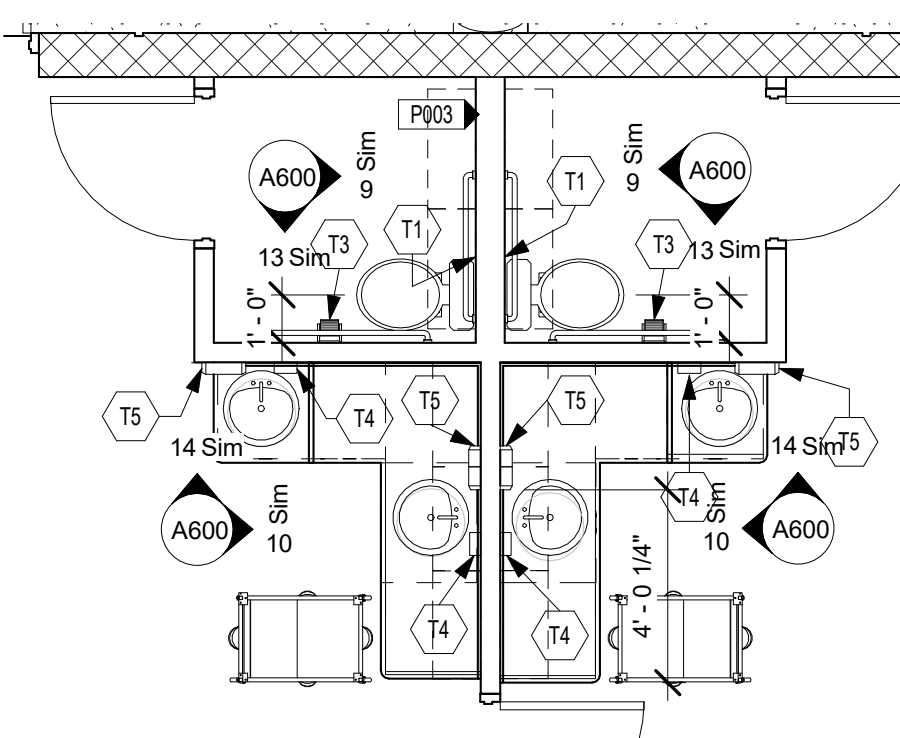

**1 ENLARGED PLAN - TODDLER/TWO'S CLASSROOM TOILET**  
SCALE: 1/4" = 1'-0"

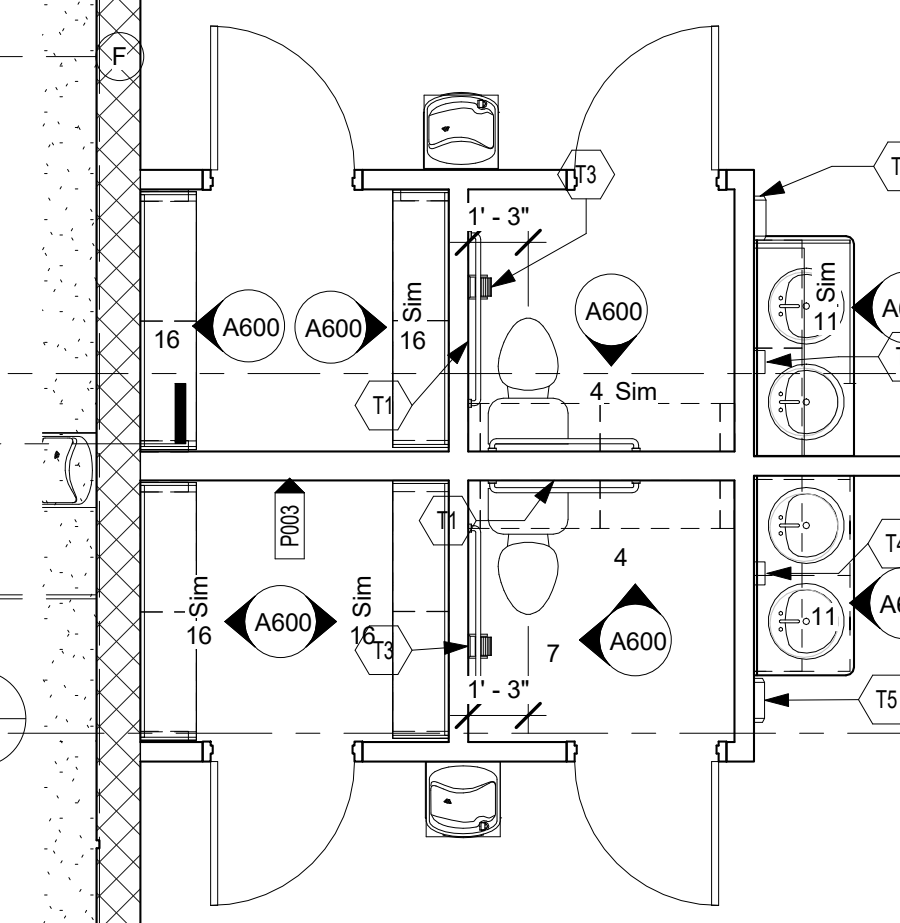

**1 ENLARGED PLAN - CLASSROOM TOILET**  
SCALE: 1/4" = 1'-0"

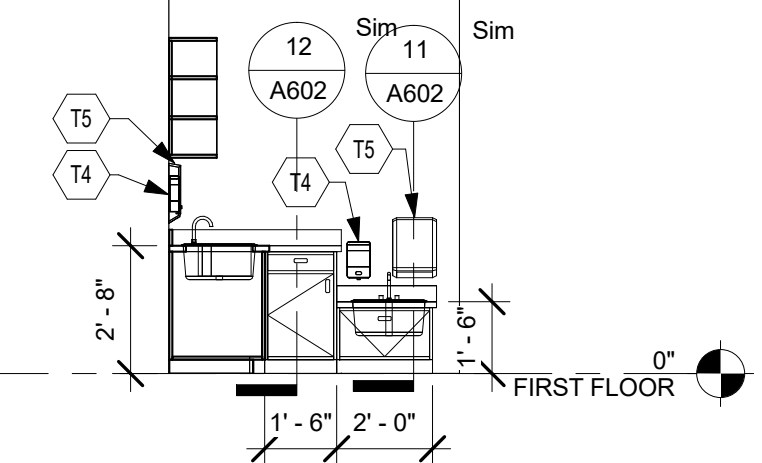

**14 TODDLER CLASSROOM - MILLWORK SIDE ELEVATION**  
SCALE: 1/4" = 1'-0"

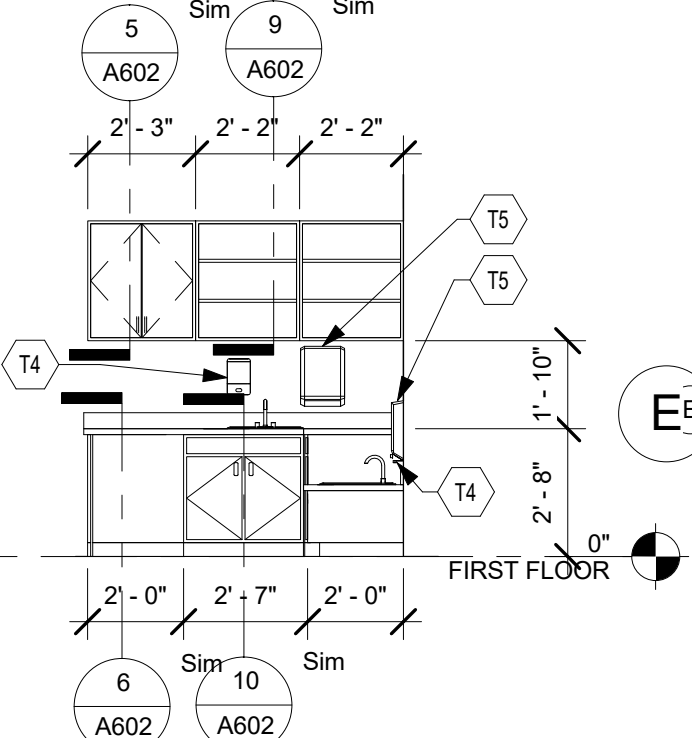

**10 TODDLERS CLASSROOM - MILLWORK FRONT ELEVATION**  
SCALE: 1/4" = 1'-0"

**KEYNOTES**

08 70 00.A1 S.S. COAT HOOK US32D

**SHEET NOTES**

- N22 ALUM. ACCESS LADDER MODEL 501 WITH SAFETY POST AS MFD. O' KEEFFS INC.
- N25 MOPSINK REFER TO PLUMBING DRAWINGS
- N26 FIRE EXTINGUISHER CABINET
- N28 OWNER FURNISHED REFRIGERATOR
- N29 OWNER FURNISHED DRYERS
- N30 OWNER FURNISHED WASHER
- N39 OWNER FURNISHED WIRE SHELFING UNIT

**TOILET ACCESSORY SCHEDULE**

ALL MODEL NUMBERS BASED ON SELECTED WASHROOM EQUIPMENT WITHIN SPECIFICATIONS UNLESS OTHERWISE NOTED

MARK	DESCRIPTION
T1	GRAB BAR
T2	MIRROR
T3	TOILET TISSUE DISPENSER
T4	SOAP DISPENSER
T5	PAPER TOWEL DISPENSER

**EQUIPMENT SCHEDULE**

A	ADVANCE TABCO	FC-3-1824-18RL	SINK, 3 COMPARTMENT, OVERALL 30" F/B x 90" L/R, 18" DRAINBOARDS LEFT & RIGHT, S/S LEGS
A1	KROWNE METAL	14-814 L	FAUCET, 8" CENTERS, 1/4" SWING NOZZLE, REMOVABLE CARTRIDGE VALVE ASSEMBLY
B	ADVANCE TABCO	DTC-S70-48L	DISHTABLE, CLEAN S/S LEGS, 47" LONG, 16/304 STAINLESS CONSTRUCTION
C	SALVAJOR	100-SA-3-MRSS	DISPOSER WITH MANUAL REVERSING MRSS CONTROL, 208V/60HZ/1-PH, 10.2 AMPS
C1	SALVAJOR	LSA8	DISPOSER SUPPORT LEG
D	ADVANCE TABCO	DTS-S70-48R	DISHTABLE, SOILED WITH PRE-RINSE SINK, S/S LEGS, 47" LONG
D1	ADVANCE TABCO	DTA-100	PRE-RINSE BASKET
D2	ADVANCE TABCO	K-452	CONTROL BRACKET 8"x12", FOR SALVAJOR 100SA-3-MRSS CONTROLS
D3	KROWNE METAL	17-108WL	PRE-RINSE ASSEMBLY WALL MOUNTED 8" CENTERS W/ WALL BRACKET
E	ADVANCE TABCO	DT-6R-23	SORTING SHELF, TUBULAR DESIGN 24" DEEP x 62" LONG, MOUNT 5'-0" AFF
F	TURBO AIR	TSR-49SD	REFRIGERATOR, REACH-IN, 2 DOOR W/STAINLESS INTERIOR, 115V/60/1, 9.2 AMPS, 4" CASTERS
G	TURBO AIR	TSF-49SD	FREEZER, REACH-IN, 2 DOOR W/STAINLESS INTERIOR, 115V/60/1, 10.3 AMPS, 4" CASTERS
J	ADVANCE TABCO	7-PS-83	HAND SINK WITH TOWEL & SOAP DISPENSER 9"x9"x5" DEEP, DECK MOUNTED FAUCET CORNER MACHINE, DOOR TYPE, S.S. 3/4" HP, 115V/60/1, 11.4 AMP
K	JACKSON WWS	CONSERVER XL-E-C	CORNER MACHINE, DOOR TYPE, S.S. 3/4" HP, 115V/60/1, 11.4 AMP
L	ADVANCE TABCO	SKG-306	WORK TABLE, 30" WIDE TOP, 72" LONG, 5" BACKSPLASH, ADJUSTABLE S/S UNDERSHELF, S/S BULLET FEET
L.1	ADVANCE TABCO	SS-2015	2 DELUXE DRAWERS, MODIFIED TO 15"x20"x5" S/S W/ DRAWER SLIDES
L.2	ADVANCE TABCO	TA-31	2 SIDE SPLASHES, 5" HIGH
N	ADVANCE TABCO	SKG-308	WORK TABLE WITH RIGHT SINK (16"x20"x12" DP BOWL), 30" WIDE x 96" LONG, DECK FAUCET
N.1	ADVANCE TABCO	SS-2015	DELUXE DRAWER, MODIFIED TO 15"x20"x5" S/S W/ DRAWER SLIDES
O	ADVANCE TABCO	SAG-366	WORK TABLE, 36" X 72" S/S TOP, WITHOUT SPLASH, FRAME & ADJUSTABLE UNDERSHELF, BRAKES ON ALL CASTERS
O.1	ADVANCE TABCO	TA-25B	SONIC STEAMER MICROWAVE OVEN, 2100 WATTS, 208V/60/1-PH, 20 AMP
P	PANASONIC	NE-2180	TRASH RECEPTACLE
Q	N&N	24	CAN RACK, PROVIDED BY OWNER
R	MVP GROUP	AX-824H	AXIS CONVECTION OVEN, FULL SHEET PAN CAPACITY, 3900W, 208V/60/1-PH, 16.5 AMP
T	ADVANCE TABCO	WS-12-96	SHELF, WALL MOUNTED, 12" WIDE, 96" LONG S/S, MOUNT 5'-0" AFF.
U	CAPTIVE-AIRE	4830VH-B-G	4'-0" LONG CONDENSATE DISHWASHER HOOD SYSTEM WITH PERIMETER GUTTER
U.2	CAPTIVE-AIRE	STAINLESS PANELS	430 SS - 72"x48" BACKSPLASH, INCLUDES END CAPS AND DIVIDER BARS

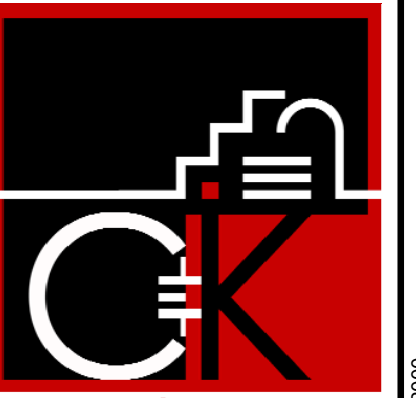

**ARCHITECTS INTERIORS, INC.**  
architectural interior design-client services  
AIA/CES 12/22

4301 Anchor Plaza Parkway, Ste 100  
Tampa, FL 33634-7525  
813.884.2000

280 West Central Avenue  
Winter Haven, FL 33880-2957  
863.577.2054

BRYAN L. KARSKY

DESCRIPTION

NO. DATE BY

CONSTRUCTION DOCUMENTS  
**RESTROOM PLANS, ELEVATIONS, SECTIONS**  
DAYCARE FACILITY FOR  
**CREATIVE WORLD SCHOOL**  
NAPLES, FL  
VANDERBILT BEACH RD.

ISSUED FOR:  
PROJECT NUMBER:  
15098  
DATE:  
9.21.2018  
DRAWING NUMBER:

**A600**

## **LARRY M. SCHNEIDER, AIA**

Architect - Accessibility Consultant

### **EDUCATION**

UNIVERSITY OF FLORIDA - Bachelor of Architecture

### **REGISTRATION**

Architect: Florida No 7443  
Certified: NCARB No 21783  
Past: Certified Building Inspector No CBI-110  
Past: Certified Building Plans Examiner CBPE-110  
Approved: Course Accreditor for the Florida Building Commission - Advanced Building Code Courses  
Approved: Course Provider by the Florida Building Commission  
Approved: Provider for Continuing Education Courses - Board of Architecture and Interior Designers  
- Architects  
- Interior Designers  
Courses Provided  
- Advanced Accessibility Compliance - The Good The Bad The Ugly Or Why Did I Do That???? Course Number 9877506  
- Advanced Fair Housing Act OR The Seven Deadly Sins of the FHA Course Number 9877899  
- The ABC's of the New ADA and the FACBC - Advanced Course Number 9878206  
- FACBC and ADA Accessibility Standards for Medical/Hospital Facilities – Advanced Course Number 9878.906

### **PROFESSIONAL AFFILIATIONS**

Past Member/ STATE OF FLORIDA  
Chairman - State Board of Building Codes and Standards  
Member FLORIDA BOARD OF BUILDING CODES AND STANDARDS/FLORIDA BUILDING COMMISSION  
- Accessibility Technical Assistance Committee  
- ADAAG Workgroup to Update the Current Florida Accessibility Code to be in Harmony with the 2010 ADAAG Standards as Adopted by the DOJ  
Past Member - Accessibility Ad Hoc Committee to write a Florida Accessibility Training Manual for the FACBC  
- DCA Accessibility Code Training, Train the Trainer Task Force on the FACBC  
- Technical Assistance Committee for Accessibility in Creating the new Florida Building Code  
- Accessibility Ad Hoc Committee as it relates to requirements for Accessible Parking Requirements  
- Product Approval Working Group  
- ICC Participation Workgroup  
- Participant Movie Theater Design Charette  
- Participant Hotel Guest Room Design Charette  
Member ANSI A117.1 COMMITTEE  
- Committee Establishing the Standards for Accessible and Usable Buildings and Facilities as Referenced by the International Building Code (ICC)  
Past Member/ STATE OF FLORIDA STATE FIRE MARSHAL  
Chairman - Fire Code Technical Advisory Committee  
Member - State Fire Marshal Fire Code Advisory Council  
Member AMERICAN INSTITUTE OF ARCHITECTS  
- Past Regional Director - Florida/Caribbean Region  
- Past Member AIA National Board of Directors  
- Past Member Accessibility Task Force to Review and Respond to the ADA Guidelines  
- Past Member AIA Codes and Standards Committee  
- Past Member AIA ADA Committee  
- Past Member AIA Documents Committee

## LARRY M. SCHNEIDER, AIA

Architect - Accessibility Consultant

- Member
  - AIA FLORIDA
    - Past State President
    - Past State First Vice President-President Elect
    - Past State Treasurer
    - Past State Vice President
  - Past Member Board of Directors
- Past Chairman
  - Codes and Standards Task Force
  - Palm Beach Chapter
    - Past President
    - Past Vice President
    - Past Secretary
    - Past Treasurer
    - Past State Director
    - Past Chapter Director
- Past President CONSTRUCTION SPECIFICATIONS INSTITUTE
  - Palm Beach Chapter
- Past Member/  
Chairman PALM BEACH COUNTY
  - Fire Code Board of Appeals & Adjustment
  - Building Code Advisory Board
  - Fire Code Advisory Board
- Past Member STATE OF FLORIDA
  - Department of Community Affairs/Handicap Committee
- Past Member STATE OF FLORIDA
  - Hurricane Andrew Workshop Member/Department of Community Affairs
  - Hurricane Andrew Investigative Task-Force/Department of Community Affairs
- Past Member CITY OF DELRAY BEACH CHAMBER OF COMMERCE
  - Blue Ribbon Task Force
- Past Member CITY OF DELRAY BEACH
  - Planning and Zoning Board
- Past Member VILLAGE OF PALM SPRINGS
  - Planning and Zoning Board
  - Code Enforcement Board
- Past Member/  
Treasurer BUSINESS COALITION FOR AMERICANS WITH DISABILITIES - DADE COUNTY
- Member AMERICAN INSTITUTE OF ARCHITECTS
- Member INTERNATIONAL CODE CONGRESS (ICC)
  - Past Committee Member Accessibility Exam Development Committee
- Member BUILDING OFFICIALS ASSOCIATION OF FLORIDA
  - Past Committee Member - Code Development Committee
  - Member - Code Interpretation Committee
- Member NATIONAL FIRE PROTECTION ASSOCIATION
- Member FLORIDA FIRE MARSHALS AND INSPECTORS ASSOCIATION
- Member NATIONAL ASSOCIATION OF ADA COORDINATORS
- Member AMERICAN ASSOCIATION OF PEOPLE WITH DISABILITIES
- Member FLORIDA ASSOCIATION OF HOUSING AND REDEVELOPMENT OFFICIALS
- Member UNITED STATES GOLF ASSOCIATION
- Member FLORIDA STATE GOLF ASSOCIATION
- Facilitator AMERICAN INSTITUTE OF ARCHITECTS
  - AIA National Seminar on the Americans with Disabilities Act
- Speaker AMERICAN INSTITUTE OF ARCHITECTS
  - AIA National Grassroots
  - National Conference - Building Performance: The Competitive Edge Addressing Accessibility Issues

## LARRY M. SCHNEIDER, AIA

Architect - Accessibility Consultant

- AIA National Convention
  - ADA - The Good, The Bad and The Ugly or Why Did I Do That?
- AIA Texas State Conference
- AIA Oklahoma State Conference
- AIA Wisconsin Conference
- Speaker AMERICAN INSTITUTE OF ARCHITECTS and the ARCHITECTURAL & TRANSPORTATION BARRIERS COMPLIANCE BOARD
- Speaker - Universal Accessibility Conference, Washington, DC  
STATE OF FLORIDA FIRE MARSHAL'S ASSOCIATION
- Speaker - Presenter Regarding the Codes and the Relationship of the Fire Marshal and the Architect  
AIA FLORIDA
- Seminars on ADA and the Florida Accessibility Code around the State of Florida 1993 - 2014
- Seminars on the Fair Housing Act around the State of Florida 2000 - 2014
- Seminars on the Florida Building Code - Building/Fire Code Relationship
- Speaker NATIONAL ASSOCIATION OF ADA COORDINATORS - 2010
- Speaker BUILDING OFFICIALS ASSOCIATION OF FLORIDA
- Speaker - Accessibility Compliance seminars around the State of Florida  
CONSTRUCTION SPECIFICATIONS INSTITUTE
- CSI National Convention - Washington, DC
- CSI National Convention - Baltimore, MD
- Speaker FLORIDA COORDINATING COUNCIL ON ADA
- State Seminar on ADA and the State Accessibility Code
- Speaker STATE OF FLORIDA GOVERNOR'S ADA WORKING GROUP (ADAWG)
- State Seminar on ADA and the Florida Accessibility Code
- Speaker HILLSBORO COUNTY ADA COMPLIANCE FOR SMALL BUSINESSES CONFERENCE
- ADA Compliance for Small Business Workshop – Where to Start and What to Look for; Practical Solutions to Technical Requirements - 2013
- Speaker PALM BEACH COUNTY OFFICE OF EQUAL OPPORTUNITY
- Accessibility Seminars on the Requirements of the Fair Housing Act, the ADA and the Florida Accessibility Code – 2010, 2012, 2014
- Speaker CITY OF JACKSONVILLE ADA COORDINATORS OFFICE – ADA SYMPOSIUM
- Fair Housing and the ADA - 2012
- The ABC's of the New ADA and the FACBC Advanced Course - 2014
- Speaker INTERNATIONAL INTERIOR DESIGN ASSOCIATION (IIDA) CEU BLITZ 2013
- The ABC's of the New ADA and the FACBC Advanced Course
- Speaker INTERNATIONAL FACILITY MANAGEMENT ASSOCIATION – SUNCOAST CHAPTER - FLORIDA
- The ABC's of the New ADA and the FACBC - 2014
- Speaker FIRE INSPECTOR ASSOCIATION OF BROWARD COUNTY
- Meeting the Requirements of the FFPC, the 2010 ADA Standards and the 2012 FACBC – Who's Really In Charge????
- Speaker NATIONAL ACADEMY OF BUILDING INSPECTION ENGINEERS (NABIE) 2014 ANNUAL BUILDING INSPECTION ENGINEERING CONFERENCE
- Advanced Accessibility Compliance - The Good, The Bad, The Ugly – Or Why Did I Do That???
- Speaker STATE OF FLORIDA COURT ADA COORDINATOR EDUCATION PROGRAM
- The Top Ten Things Court ADA Coordinators Need to Know about the 2010 ADA and the 2012 FACBC – 2012
- Speaker SMALL BUSINESS DEVELOPMENT CENTER HILLSBOROUGH COUNTY
- ADA Compliance For Small Businesses – 2013
- Speaker 2010 ADA REGULATIONS & DESIGNS STANDARDS SYMPOSIUM - TAMPA
- Additions, Alterations, Historical Structures & Applying the NEW FACBC Requirements – 2013

## **LARRY M. SCHNEIDER, AIA**

Architect - Accessibility Consultant

- Speaker SCHOOL DISTRICT PALM BEACH COUNTY  
- Title II and III Issues of the ADA and the State Accessibility Code
- Speaker SCHOOL DISTRICT MIAMI - DADE COUNTY  
- Title II and III Issues of the ADA and the State Accessibility Code
- Speaker MIAMI - DADE COUNTY BUILDING DEPARTMENT  
- Requirements of the ADA, the Florida Accessibility Code, and the Fair Housing Act
- Speaker CITY OF MIAMI CIP DEPARTMENT  
- Requirements of the ADA and the Florida Accessibility Code
- Speaker AEC 96 CONFERENCE  
- Accessibility Conflicts - Accessibility Solutions
- Speaker PROFESSIONAL SEMINARS GROUP  
- FACBC/ADA Update 1997 - 2004 around the State of Florida
- Speaker CSI ORLANDO CONSTRUCTION DESIGN EXPO 1998
- Speaker CITY OF HOLLYWOOD, FLORIDA  
- FACBC/ADA Update
- Speaker CITY OF MIAMI BEACH, FLORIDA  
- FACBC/ADA Update
- Speaker SOUTH FLORIDA BUILDING CODE EDUCATIONAL CONFERENCE  
- FACBC Update 1997, 1998, 2000, 2006, 2008, 2011, 2012
- Speaker AIA CENTER FOR BUILDING PERFORMANCE AND REGULATIONS  
- Accessibility Panel Discussion
- Speaker US DEPARTMENT OF HUD  
- Workshop on Accessible Residential Housing Design and Construction
- Speaker FLORIDA PETROLEUM MARKETERS & CONVENIENCE STORE ASSOCIATION  
- Accessibility Compliance
- Speaker FLORIDA EDUCATIONAL FACILITIES PLANNERS ASSOCIATION (FEFPA)  
- The ABC's of the ADA and the FACBC - 2004  
- Florida Accessibility Code for Building Construction Chapter 11 Advanced – 2007, 2009  
- The ABC's of the New ADA and the FACBC Advanced Course - 2014
- Speaker COLEGIO DE ARQUITECTOS DE PUERTO RICO  
- The ABC's of ADA
- Speaker BROWARD COUNTY, FLORIDA ADA SYMPOSIUM – 2012 & 2014
- Speaker CITY OF JACKSONVILLE, FLORIDA ADA SYMPOSIUM BREAKING DOWN BARRIERS – 2012  
- FACBC & ADA Accessibility Standards for Medical/Hospital Facilities Advanced  
- The ABC's of the New ADA and the FACBC  
- Advanced Fair Housing Act
- Speaker NATIONAL ASSOCIATION OF ADA COORDINATORS CONFERENCE  
- Hold the Airplane - I Want to Get On Accessibility Seminar - 2010
- Speaker RON BLANK & ASSOCIATES, INC. – NATIONAL SPEAKER PROVIDER  
- The ABC's of the New ADA and the FACBC - Advanced - 2014  
- FACBC and ADA Accessibility Standards for Medical/Hospital Facilities – Advanced - 2013
- Speaker FLORIDA AGENCY FOR HEALTHCARE ADMINISTRATION  
- The ABC's of the New ADA and the FACBC - Advanced - 2015  
- FACBC and ADA Accessibility Standards for Medical/Hospital Facilities – Advanced – 2013
- Speaker CITY OF JACKSONVILLE, FLORIDA 6<sup>TH</sup> ANNUAL ADA SYMPOSIUM – 2017  
- Discussions include:
  - What's Happening in the ADA
  - Why are there still lawsuits after 25 years of the ADA?
  - Panel discussion of the ADA from the user's standpoint
  - Best practices of the ADA

## **LARRY M. SCHNEIDER, AIA**

Architect - Accessibility Consultant

- Code Plus
  - The next set of regulations
  - Website lawsuits
- Speaker CITY OF ALTAMONTE SPRINGS, FLORIDA  
- Compliance with the ADA and the FACBC for Parking, Parking Lots and Site Access – 2017
- Speaker CITY OF MIAMI BEACH BUILDING DEPARTMENT, FLORIDA – 2018  
- The ABC's of the New ADA and the FACBC  
- Advanced Fair Housing Act
- Speaker LEE COUNTY BUILDING DEPARTMENT, FT. MYERS, FLORIDA – 2018  
- The ABC's of the New ADA and the FACBC  
- Advanced Fair Housing Act
- Speaker BROWARD COUNTY BOARD OF RULES AND APPEALS, FT LAUDERDALE, FLORIDA – 2018  
- The ABC's of the New ADA and the FACBC
- Speaker CITY OF JACKSONVILLE, FLORIDA – ADA SYPOSIUM 2018  
- The ABC's of the New ADA and the FACBC
- Speaker NUMEROUS ARCHITECTURAL FIRMS IN FLORIDA – 2018  
- The ABC's of the New ADA and the FACBC
- Speaker ASID CHAPTER – TAMPA BAY, TAMPA, FLORIDA – 2018  
- The ABC's of the New ADA and the FACBC
- Speaker IIDA SOUTH FLORIDA CHAPTER, FT LAUDERDALE, FLORIDA – 2018  
- The ABC's of the New ADA and the FACBC
- Published AIA FLORIDA  
- Accessibility Compliance - Accessibility Compliance with the Florida Accessible Toilet Room
- Published UNIVERSAL DESIGN NEWSLETTER
- Published POCKET GUIDE TO THE FLORIDA ACCESSIBILITY STANDARDS  
- Numerous Editions of Pocket Guide to the Florida Accessibility Standards 1994 – 2010  
Co-Editor with Evan - Terry Associates
- Published ACE NEWS (Architectural, Construction & Engineering) at MIA  
- Value Analysis at Miami International Airport Part I  
- Value Analysis at Miami International Airport Part II

## **CONTINUING EDUCATION**

Key Bridge Foundation 40 Hour ADA Mediation Training  
Harvard University Graduate School of Design - Advanced Training in ADA and UFAS Design Compliance  
Value Engineering Module I Training in the Process and Facilitating a Value Engineering Study  
Value Engineering Module II Training in the Process and Facilitating a Value Engineering Study  
Personnel Law Update - Council on Education in Management  
Department of Community Affairs Florida Accessible Code Seminar(s)  
Fair Housing Act Requirements  
Fair Housing Act Amendments Accessibility Guidelines  
Avoiding the Most Common ADA Errors  
Proposed Changes to the ADA  
When Architect and Attorneys Collide  
ADA: Where Are We Going With the Law  
Requirements for Existing Facilities Under ADA Title III  
ADA Risk Management  
ADAAG Review and Harmonization  
ABCs of ADA Bridging Accessibility into Project Process



## LARRY M. SCHNEIDER, AIA

Architect - Accessibility Consultant

Role a Mile in My Chair - Understanding ADAAG  
ADA Liability - Who is Responsible Under the Act  
Concept of Universal Accessibility  
Requirements for Existing Public Housing  
Fair Housing Accessibility First  
    Fair Housing Act Accessibility Requirements  
    Strategies for Compliant Bathrooms  
    Strategies for Compliant Kitchens  
ADA National Coordinators Conference 2005 and 2007, 2008, 2009, 2010  
    - Accessibility Track  
The IBC: A Step-by-Step Process  
Building for Accessibility Affects Our Lifecycle  
National Association of ADA Coordinators Conference – 2008, 2010, 2014  
AIA Regional and Urban Design Knowledge Community Seminar  
National Center on Accessibility for Recreation and Parks Seminar  
National ADA Symposium – St. Petersburg, FL  
Harvard Graduate School of Design – ADA and Access to Public and Private Non-Residential Facilities and Programs  
Harvard Graduate School of Design – Fair Housing, ADA, ABA, and 504 Access to Housing and Dorms

### RECIPIENT

State of Florida	Governor's Award for Extraordinary Title III Compliance Award
Metro-Dade County	Award for Outstanding Activities that Enhance and Promote Opportunities for Persons with Disabilities
AIA	AIA National 2000 Component Excellence Award for an Outstanding Individual Contribution to Government Affairs for Spearheading Legislation to Establish a Unified Statewide Building Code for the State of Florida
AIA	Upjohn Fellows Award
AIA Florida	AIA Florida Gold Medal for Continual and Outstanding Service to the Profession, the Community and to the State
AIA Florida	AIA Florida Charles W. Cleary Government Service Award for Service to the Profession, the Community and to the State
AIA Florida	Anthony L. Pullara Award for Outstanding Service to the Architectural Profession
AIA Florida	President's Award for Outstanding Service as Chairperson of the Florida Board of Building Codes and Standards
AIA Florida	State of Florida Unbuilt Design Award for the Palm Beach County South County Civic Center
AIA Palm Beach	AIA Palm Beach Gold Medal for Continual and Outstanding Service to the Profession, the Community and to the Chapter John Stetson Memorial Award for Outstanding Service to the Architectural Profession and to the Chapter
AIA Palm Beach	Design Award for Excellence Interstate Centre Design Award for Excellence Temple Sinai Design Award for Excellence 25 Seabreeze Office Building Design Award for Excellence Old School Square Cultural Arts Center Design Award for Excellence Dr. Jared Residence Design Award for Excellence Delray Beach Fire Station No 2 Design Award for Auburn Trace a Low Income Housing Project
Delray Beach Housing Authority	
City of Delray Beach Community Appearance Board	Design Award for Delray Beach Life Guard Station Design Award for 25 Seabreeze Office Building

## **LARRY M. SCHNEIDER, AIA**

Architect - Accessibility Consultant

State of Florida	Award for Meritorious Achievement for Historical Preservation Old School Square
Trust for Historical	1913 Building
Preservation	Award for Meritorious Achievement for Historical Preservation Old School Square
	1926 Gymnasium

### **ACCESSIBILITY CONSULTING SERVICES**

Hotels	Cruise Ships	Shopping Centers/Malls
Hospitals	Governmental Entities (Title II Requirements)	Medical Centers
Airports	Public Schools	Movie Theaters
Restaurants	Recreational Facilities	Office Buildings
Condominiums	Amusement/Entertainment Parks	Apartment Complexes

### **REPRESENTATIVE CLIENT/PROJECT LIST**

Miami International Airport - Miami, Florida	Miami Science Museum - Miami, Florida
Nassau County, Florida	Hyatt Regency Hotel, Coral Gables, Florida
Collier County, Florida	Weeki Wachee Springs - Florida
Lee County, Florida	Safeway Grocery Stores - US
St. Lucie County, Florida	Busch Entertainment/Theme Parks
Santa Rosa County, Florida	Weston Town Center - Weston, Florida
City of Miami Beach, Florida	Ritz Carlton - West Palm Beach, Florida
City of Orlando, Florida	Bal Harbour Shops - Bal Harbour, Florida
City of Hollywood, Florida	HCA Hospitals
City of Hialeah, Florida	Tenet Hospitals
City of Boca Raton, Florida	Carnival Cruise Lines
City of Naples, Florida	Holland Cruise Lines
City of Coral Gables, Florida	Royal Caribbean Cruise Lines
City of Coral Gables Golf Course	Daytona International Speedway
City of Stuart, Florida	Pizza Hut of America
City of Miami, Florida	Goodyear Tire and Rubber Company - US
City of Pompano Beach, Florida	Cracker Barrel Restaurants
City of Bonita Springs, Florida	Grand Cypress Resort – Orlando, Florida
City of Ft Myers Beach, Florida	Minto Communities Inc. - Florida
Miami-Dade County - Miami, Florida	Parrot Jungle - Miami, Florida
Orange County Convention Center, Orlando, Florida	Edison Community College - Naples, Florida
State of Florida's Supreme Court	Florida Atlantic University – Boca Raton, Florida
State of Florida Department of Management Services Surveys of Governmental Buildings	Universal Studios - Orlando, Florida
Caneel Bay Resort – Virgin Islands	PGA Tour, Inc.
Chili's International Restaurants	Mercy Hospital, Miami, Florida
Seminole Hard Rock Resort and Casino - Hollywood and Tampa, Florida	Home Depot - Florida
Miami Seaquarium - Miami, Florida	Kenco Communities – Florida
State of Florida - Keys Marine Lab	Wells Fargo Bank
Muvico Theaters - Florida	Publix Grocery Stores
Host Marriott Corporation - Florida	Boca Raton Hotel and Resort - Boca Raton, Florida
Jackson Hospital - Miami, Florida	Tampa Bay Performing Arts Center
North Broward Hospital District – Broward County, Florida	University of Florida – Ben Hill Griffin Stadium – Gainesville, Florida
Florida Atlantic University – Boca Raton, Florida	Chili's Restaurants – Florida
Pier House - Key West, Florida	Gulfstream Racetrack – Hallandale Beach, Florida

**Pro Bono Services**

Numerous County and Local Municipalities throughout the State of Florida

Numerous Architectural Firms throughout the State of Florida and the United States

**EXPERIENCE**

Larry M. Schneider, AIA is the principal of his own firm Larry M. Schneider, AIA. Prior to reopening his own firm, he was the Accessibility, Value Analysis, and Partnering Coordinator with the firm of Dade Aviation Consultants at Miami International Airport. A graduate of the University of Florida in Gainesville, Mr. Schneider received his Bachelor of Architecture degree in 1973. He has been a principal with his own architectural firm of Currie Schneider Associates AIA, PA for ten years in which the firm won numerous design awards from such groups as AIA Florida, AIA Palm Beach, the City of Delray Beach and the State of Florida Trust for Historical Preservation. In addition to his commitment to the architectural profession, Mr. Schneider's career has been enhanced by the positions he has held with various professional organizations. He has been an active member of such organizations as the Construction Specifications Institute, the Southern Building Code Congress International, the ICC, the National Fire Protection Association, and the American Institute of Architects. He has been involved with the accessibility codes for the State of Florida since 1985 where he served as a member of the Department of Community Affairs Special Task Force to rewrite the Florida Accessibility Code. This resulted in the 1990 edition of the Florida Accessibility Manual. In 1992 he was appointed to the Florida Board of Building Codes and Standards and was elected its chair in 1993 and served as the chairperson of that board until 1996. In 1993 the State of Florida decided to rewrite its accessibility code to comply with the ADA Standards and he was the representing architect on this endeavor. Again in 1997, the State of Florida decided to rewrite its accessibility code, to comply with the DOJ comments for certification of the FACBC and he was the representing architect on this undertaking. He sat on the AIA National committee to review and prepare position papers for the AIA on the proposed changes to ADAAG. He currently is the AIA representative on the ANSI A117.1 Committee that creates the national guidelines for accessibility compliance and referenced by the International Building Code. He has continued to remain active in the code process and in those issues of concern by the disabled community. He is a Past President of AIA Florida (FAAIA). He was a member of the AIA National Board of Directors representing the Florida-Caribbean Region as their Regional Director. He was Past Chairman/member of the Palm Beach County Building Code Advisory Board, Past Chairman/member of the Palm Beach County Fire Code Advisory Board and has served on local community planning and zoning boards as well as the Blue Ribbon Task Force for the City of Delray Beach. He is a recipient of the AIA Florida Gold Medal, the Charles W. Cleary Government Service Award, the Anthony L. Pullara Award for outstanding service to the architectural profession, AIA Palm Beach Gold Medal for continual and outstanding service to the profession, the community and to the chapter, and the John Stetson Memorial Award for outstanding service to the architectural profession and to the chapter. He was awarded the State of Florida Governor's Award for Extraordinary Title III Compliance Award for his work in helping the citizens and design professionals to understand the Florida Accessibility Code. He has been a speaker at past AIA Florida Conferences on Accessibility (Fair Housing, the ADA and the FACBC), a Facilitator for the AIA National Seminar on ADA, a speaker at AIA National Grassroots, AIA Texas, AIA Oklahoma and the AIA National Convention, a speaker at the CSI National Convention, a speaker at the State of Florida Fire Marshall's Convention and at numerous Building Code Officials Conferences as well as government municipalities and school boards. He currently provides general accessibility consulting services to clients in the public and private sector as it relates to Title II and III of the ADA as well as to the Fair Housing Act accessibility compliance issues.



# Certificate of Occupancy

ORANGE COUNTY DIVISION OF BUILDING SAFETY  
ALAN C. PLANTE, BUILDING OFFICIAL

201 S. Rosalind Avenue  
Orlando, Fl. 32802-2687  
Phone: 407-836-5550

DATE ISSUED: **June 27, 2016**

PERMIT NUMBER: **B14903811**

THIS CERTIFICATE IS ISSUED IN ACCORDANCE WITH THE LAWS, ORDINANCES AND REGULATIONS ENFORCED BY THE DIVISION OF BUILDING SAFETY OF ORANGE COUNTY, FLORIDA.

Tenant/Occupant: **Creative World School**

Owner: **Innovating Minds LLC**

Project Address: **1725 S Dean Rd.**

Parcel I.D. Number: **05-23-31-1900-04-000**

Contractor: **Randall Ray Birchmier**

Zoning District: **P-D**

Address: **549 Wymore Rd.**

Licence #: **CGC042156**

Building Code: **2010 Florida Building Code, Building**

THE PORTION OF THE STRUCTURE AND THE OCCUPANCY DESCRIBED IN THIS PERMIT HAS BEEN INSPECTED FOR COMPLIANCE WITH THE ABOVE REFERENCED CODE.

Square Footage: **15,487**

Maximum Floor Load Allowable: **40**

No. Of Stories: **1**

Maximum Number of Persons: **417**

Type of Construction: **Type VB**

No. of Units: **0**

Sprinkler Sys Provided: **Yes**

Sprinkler Sys Req'd: **Yes**

Building Risk Category: **II**

Use & Occupancy Type: **D (Daycare)**

Wind Speed: **139**

Wind Borne Debris Region: **N/A**

Special Conditions: **N/C DAYCARE FACILITY  
SITE WORK -B14903772**

THIS CERTIFICATE OF OCCUPANCY BECOMES INVALID UPON CHANGE OF TENANT, OCCUPANCY OR UPON ANY CHANGES TO THE BUILDING OR PREMISES, OR UPON ANY VIOLATION OF THE ZONING ORDINANCE OR ANY AMENDMENTS THERETO.

KEEP POSTED ON PREMISES

*Certificate of Occupancy*  
**PASCO COUNTY**  
*Building Inspection Division*

This Certificate issued pursuant to the requirements of the Florida Building Code certifying that at the time of issuance this structure was in compliance with the applicable ordinances of Pasco County regulating building construction or use, for the following:

Use Classification: **COMMERCIAL**

Final Inspection: **Oct 29, 2015**

Building Permit No. 861234    Occupancy Group: MPUD

Work Code: CPB

Building Address: L-5.1    3490 OAKSTEAD BLVD

Owner of Building: WELLS SR 54 LLC

Parcel ID#: 22-26-18-0000-00100-0051

Contractor: ABI COMPANIES INC

*Timothy J. Moore*  
Chief Building Official

Issue Date: November 6, 2015



# CITY OF TAMPA

## Certificate of Completion

Permit Number: BLD-17-0449742

Issue Date 7/14/2017

Project Location: 5365 Primrose Lake Cir, Tampa, Florida 33647

Owner Name and Address:

Inuja Llc 10693 Cross Creek Blvd Tampa FL

Permit Type: Commercial Miscellaneous Permit

Construction Type:

Occupancy Class:

Description of Work:

Installation of underground fireline.

530' - 6" underground fire main

2 - 6" building risers

1 - storz FDC

1 - fire hydrant assembly

Attach this permit to BLD-16-0446542

Building Official: Bob Bass

Design Occupant Load:

FBC Edition:

Automatic Fire Sprinkler System Required? Yes

Special Conditions:

The construction work has been substantially completed in accordance with applicable city, state and federal codes, so that the owner can occupy or utilize the project for its intended use.

For buildings and structures located in flood hazardous areas, the as-built elevation certificate indicating the lower floor elevation is retained in the record of the department.

Planning and Development Department  
1400 N Boulevard  
Tampa FL 33607  
Phone (813) 274-3100  
[www.tampagov.net/permits](http://www.tampagov.net/permits)



**CERTIFICATE OF OCCUPANCY**



**CITY OF ST CLOUD  
BUILDING DEPARTMENT**  
1300 Ninth St.  
St. Cloud, FL 34769

BUILDING PERMIT NO.  
16-00005142

PARCEL IDENTIFICATION NUMBER:

09 26 30 0081 0001 001 0

PROPERTY ADDRESS:  
4500 LEXINGTON BLVD

FLOOD ZONE: X  
OCCUPANCY TYPE: D  
DESIGN OCCUPANCY LOAD: 216  
(if applicable)

TYPE OF CONSTRUCTION: V-B  
AUTOMATIC SPRINKLER YES  NO  NA

OWNER/MAILING ADDRESS  
BCM Property Investments  
4500 LEXINGTON AVE

SAINT CLOUD, FL 34769

WELSH CONSTRUCTION, LLC DBA WE  
3972 W. EAU GALIE BLVD  
SUITE A  
MELBOURNE, FL 32934

\*\*\*\*\*  
THE ABOVE STRUCTURE HAS BEEN INSPECTED FOR COMPLIANCE WITH THE REQUIREMENTS OF THE 5<sup>th</sup> (2014) EDITION OF THE FLORIDA BUILDING CODES AND FLORIDE FIRE PREVENTION CODE, 2011 NATIONAL ELECTRICAL CODE, CITY CODE REQUIREMENTS AND IS APPROVED FOR THE USE AND OCCUPANCY AS STATED ON THE PERMIT

DEPUTY BUILDING OFFICIAL

FIRE MARSHAL

**Celebrating Small Town Life**

CITY OF OVIEDO  
400 ALEXANDRIA BLVD  
(407) 971-5755 - FAX 971-5820  
OVIEDO FL 32765

C E R T I F I C A T E   O F   O C C U P A N C Y

Issue Date . . . . . 3/19/18  
Parcel Number . . . . . 09-21-31-300-024A-0000  
Property Address . . . . . 975 CHAPEL ST  
OVIEDO FL 32765  
Subdivision Name . . . . .  
Legal Description . . . . .  
Property Zoning . . . . . C-1  
Owner . . . . . MTA BUSINESS SOLUTIONS LLC  
975 CHAPEL ST  
OVIEDO FL 32765  
Contractor . . . . . M PAUL GENERAL CONT/GODDARD P  
Application Number. . . . . 17-00069731 000 000  
Description of Work . . . . . COMM NEW DAY CARE  
Construction Type . . . . . TYPE V-B  
Occupancy Type . . . . . EDUCATIONAL  
OCCUPANCY LOAD: . . . . . 289.00  
OCCUPANCY USE: . . . . . DAYCARE  
SPRINKLER SYSTEM YES/NO: . . . . . YES  
BUILDING CODE EDITION YR: . . . . . 2014.00

Approved . . . . . Robert Reading CBO  
Building Official

VOID UNLESS SIGNED BY BUILDING OFFICIAL

The described portion of the structure has been inspected for compliance with the requirements of the code for the occupancy and division of occupancy and the use for which the proposed occupancy is classified.





**Lee County, Florida**  
**Division of Development Services**  
**Certificate of Occupancy**  
**COMMERCIAL**

**Date:** 02/08/2018 **PERMIT NUMBER:** COM2016-01837

**Owner Name and Address:** BAGET HOLDINGS LP  
 311 10TH ST SE NAPLES, FL 34117

**Job Address:** 11961 FAIRWAY LAKES DR FORT MYERS 33913

**Contractor /Address:** CGC060615 OWEN AMES KIMBALL CO  
 11941 FAIRWAY LAKES DRIVE  
 FORT MYERS FL 33913

**Description:** NEW PRIVATE SCHOOL

**Project Name:** CREATIVE WORLD SCHOOL

**Strap:** 07-45-26-07-0000B.0020

**Zoning:** **Fire District:** So. Trail

**Flood Elevation:** **Flood Zone:** X

**Type of Construction :** 04 Type VB **Occupancy Class :** EDUCATIONAL

**Use and Occupancy Classification:** **Occupancy Load:**  
**Sprinkler System Required:** **Sprinkler System Provided:**  
**Special Stipulations/Conditions:**

**This structure or portion thereof described above has been inspected for compliance of the Florida Building Code 5th Edition (2014) for the use and occupancy listed above.**

**BUILDING OFFICIAL**

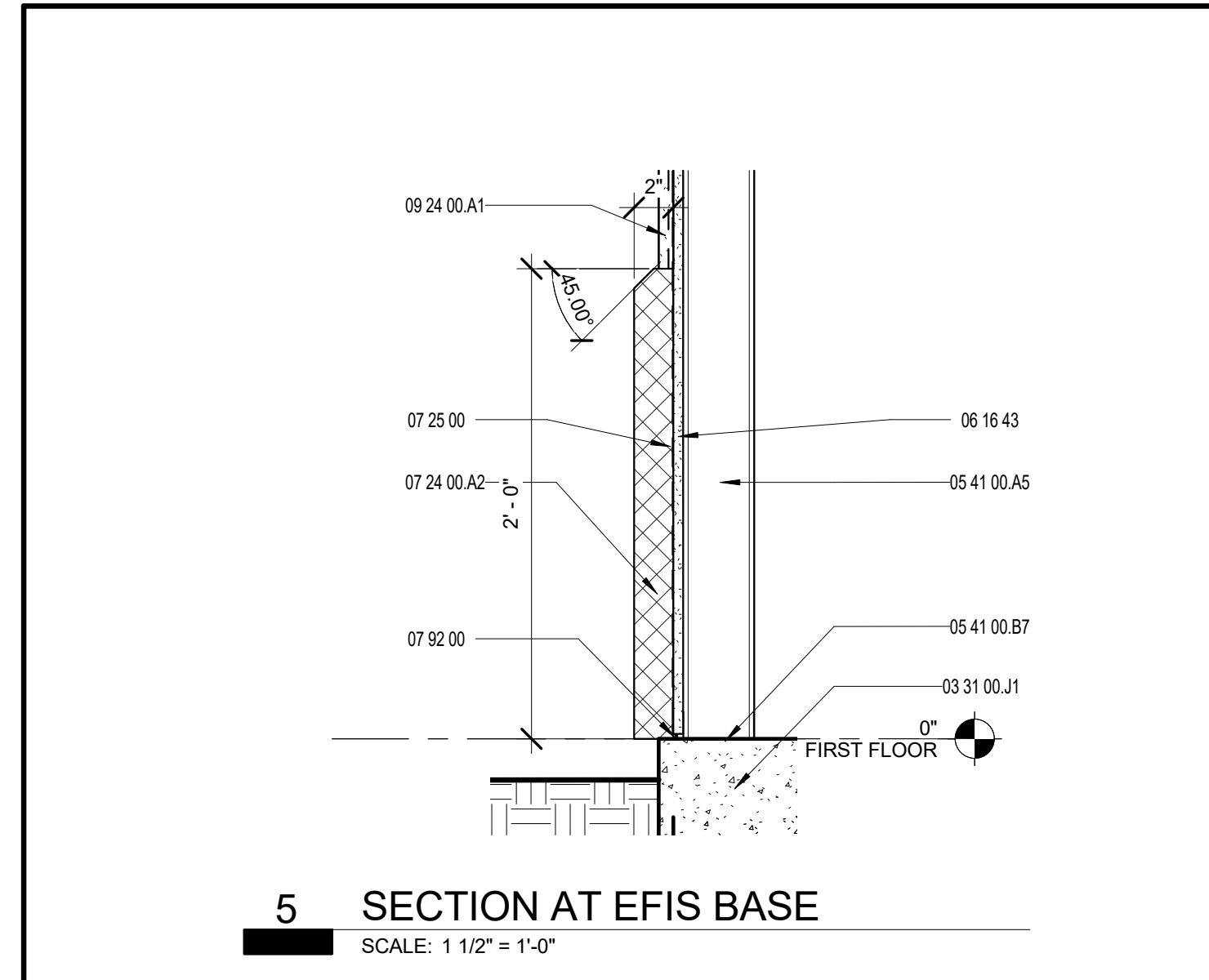

**5 SECTION AT EFIS BASE**  
SCALE: 1 1/2" = 1'-0"

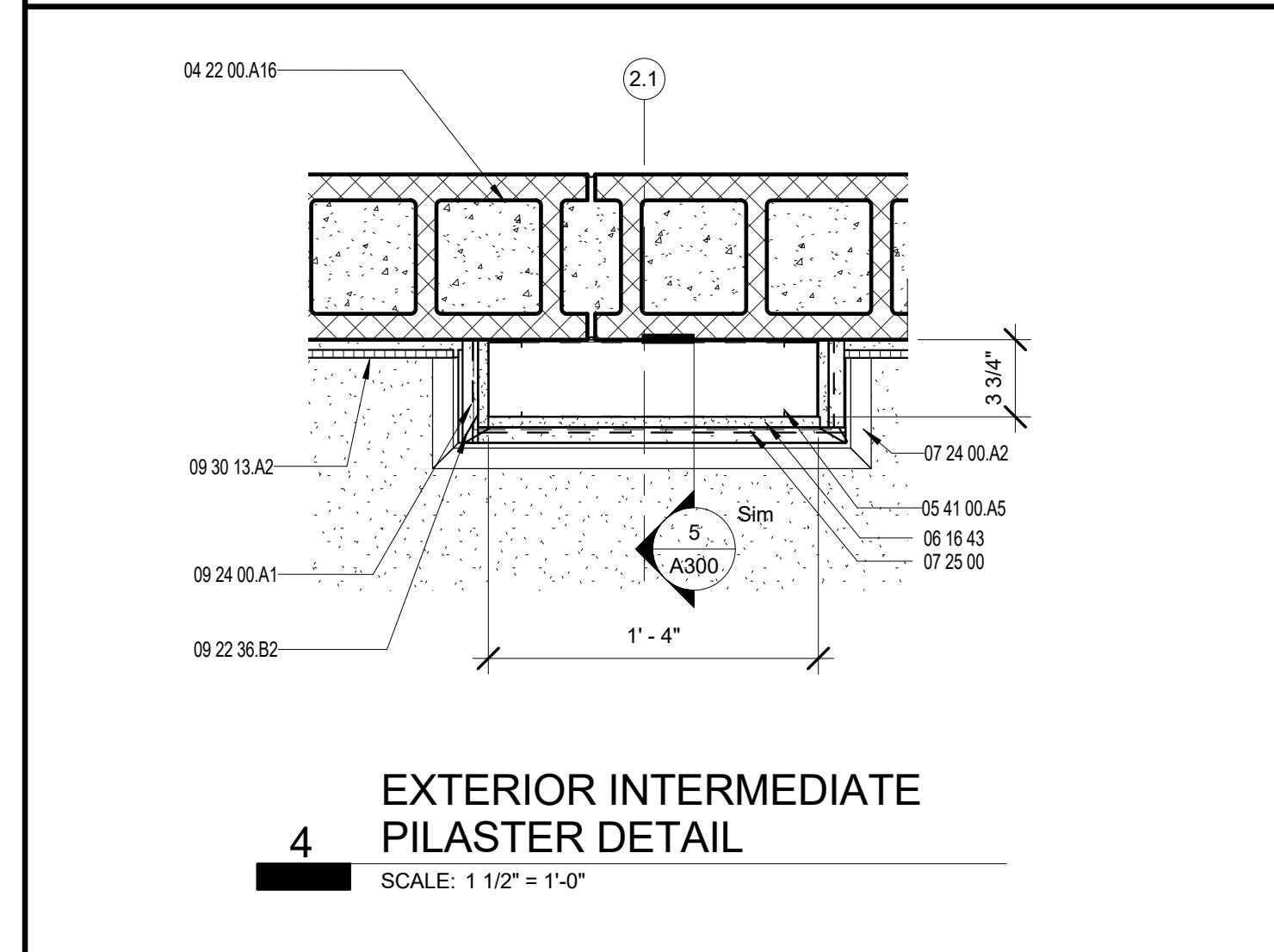

**4 EXTERIOR INTERMEDIATE PILASTER DETAIL**  
SCALE: 1 1/2" = 1'-0"

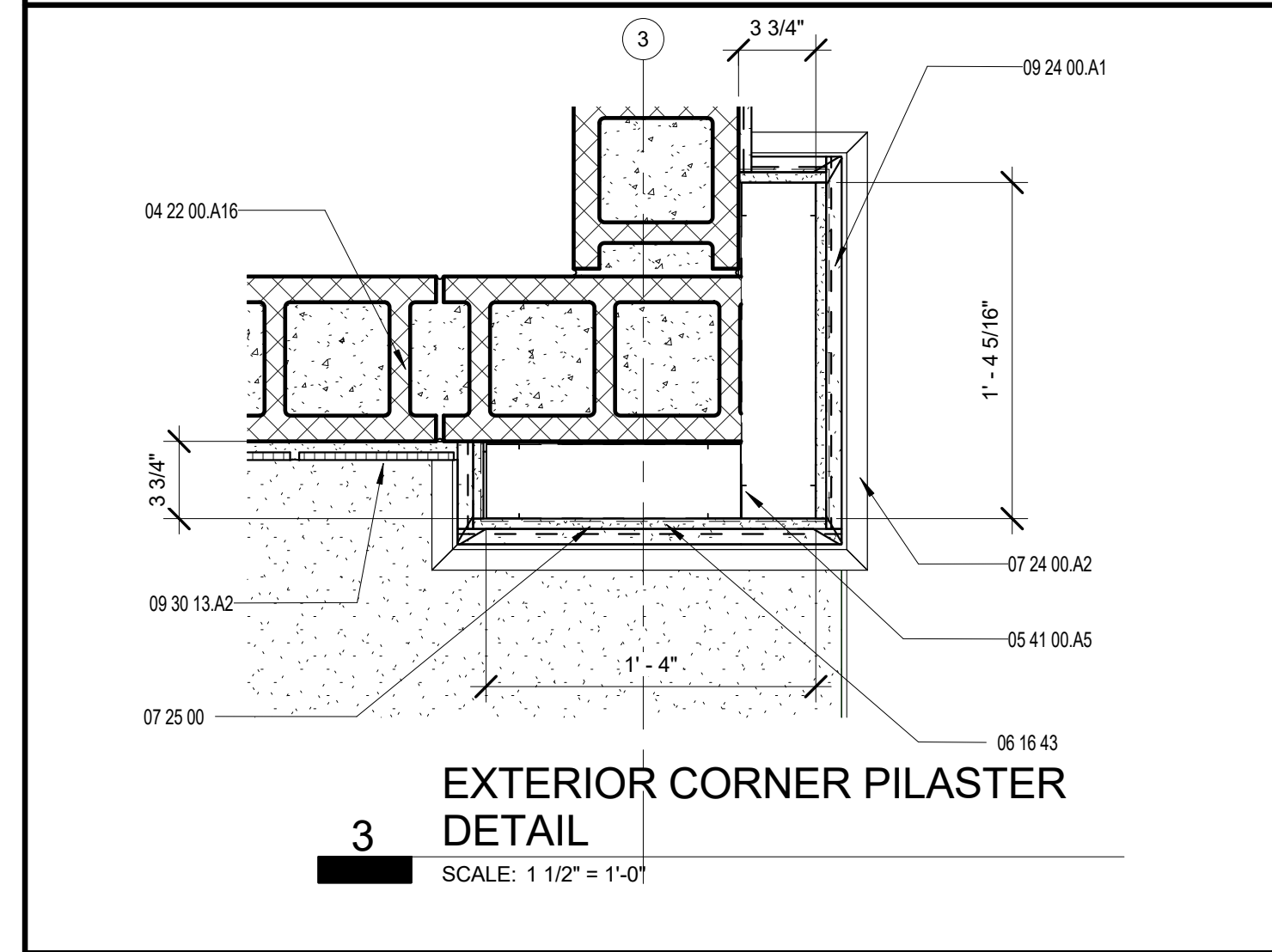

**3 EXTERIOR CORNER PILASTER DETAIL**  
SCALE: 1 1/2" = 1'-0"

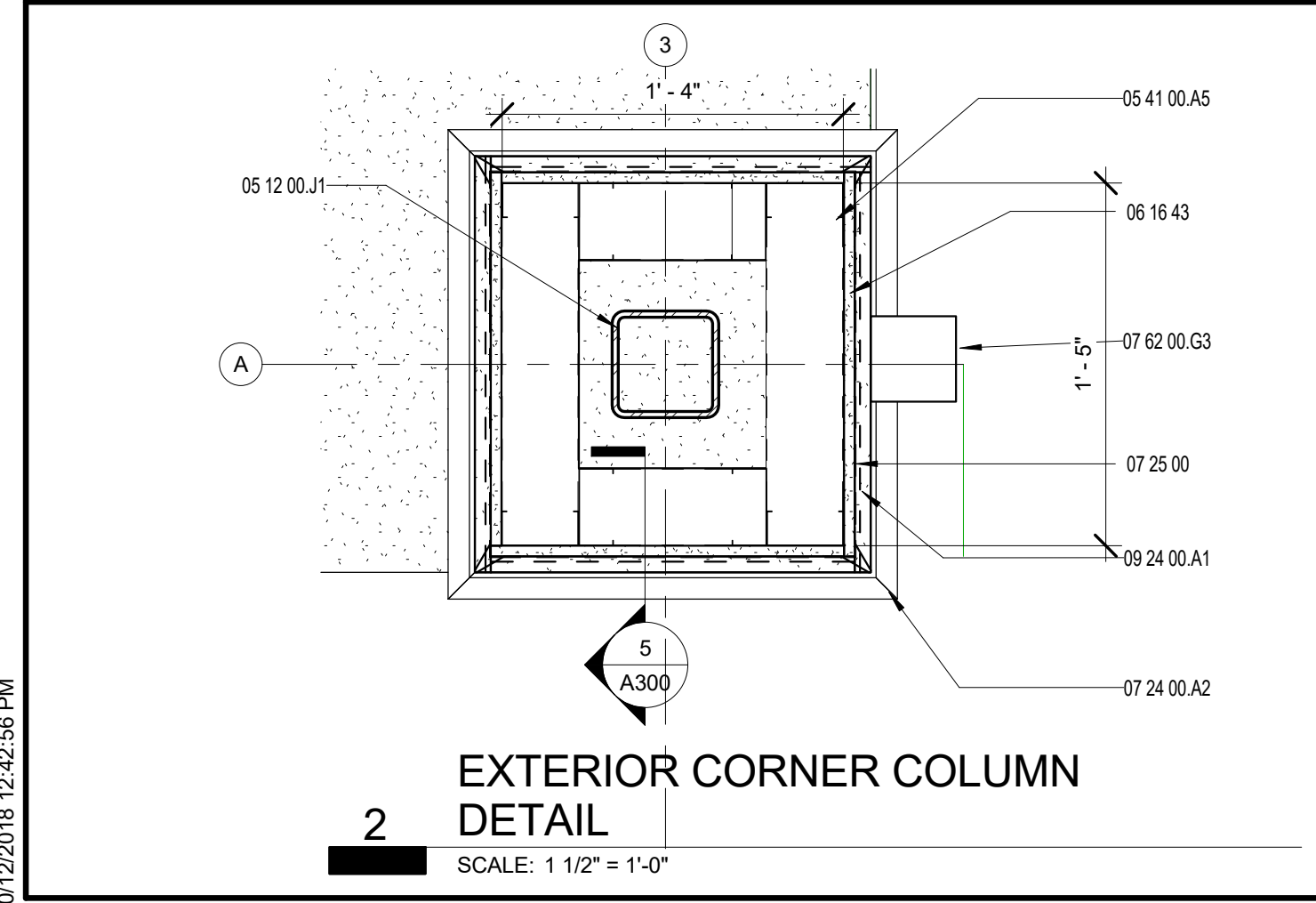

**2 EXTERIOR CORNER COLUMN DETAIL**  
SCALE: 1 1/2" = 1'-0"

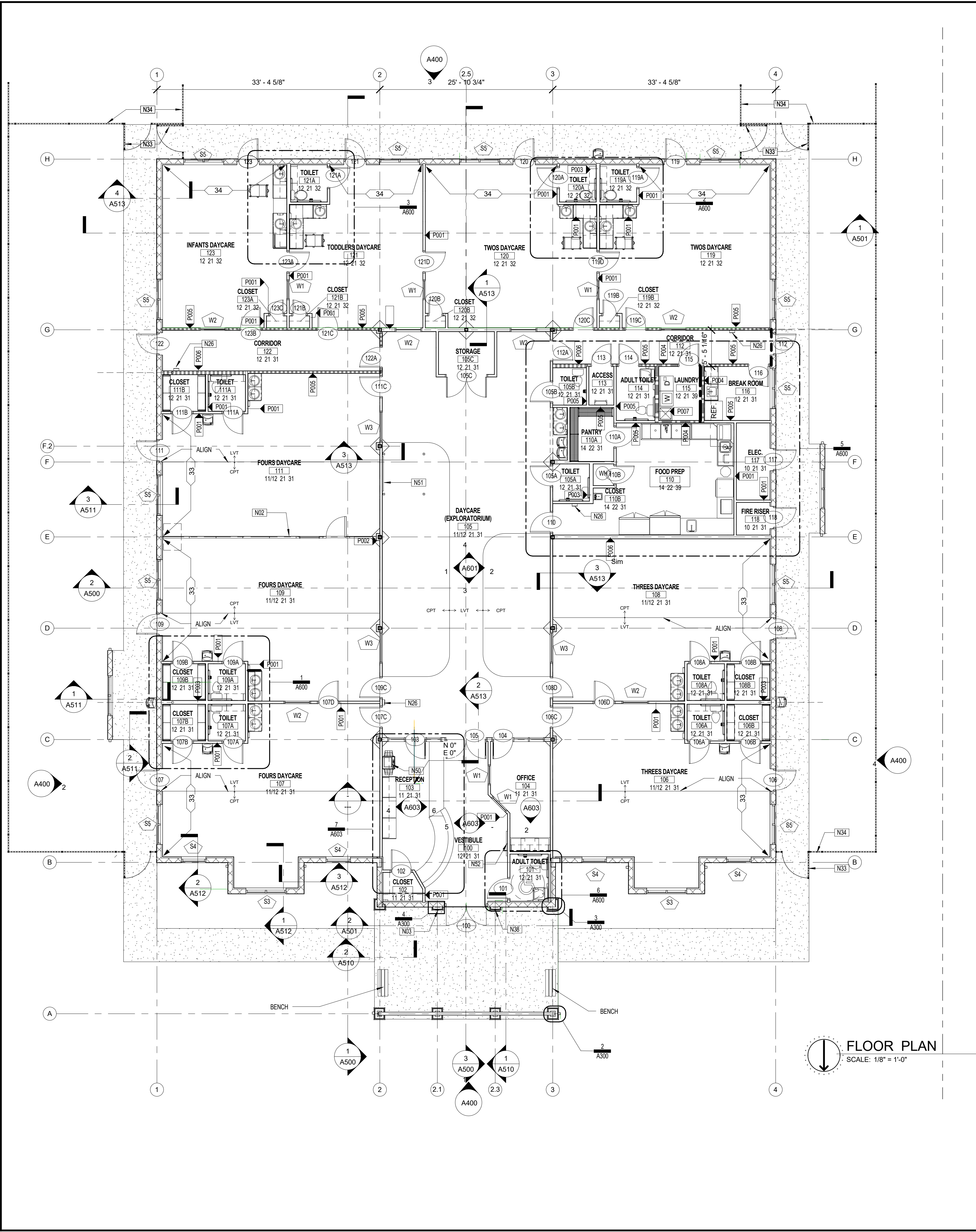

**FLOOR PLAN**  
SCALE: 1/8" = 1'-0"

**GENERAL NOTES**

- REFER TO COVER SHEET A1 FOR FLOOR AREA CALCULATIONS.
- COMPLY WITH LDC 5.05.08 F.41 SERVICE FUNCTION AREAS AND FACILITIES CONDUITS, METERS AND VENTS. CONDUITS, METERS AND VENTS AND OTHER EQUIPMENT ATTACHED TO THE BUILDING OR PROTRUDING FROM THE ROOF SHALL BE SCREENED OR PAINTED TO MATCH SURROUNDING BUILDING SURFACES. CONDUITS AND METERS CANNOT BE LOCATED ON THE PRIMARY FACADE OF THE BUILDING.
- ALL PARTITIONS TO BE TYPE P001 UNLESS NOTED OTHERWISE. REFER TO ENLARGED PLANS FOR ADDITIONAL PARTITION TYPES.
- REFER TO SHEET A320 FOR DOOR SCHEDULE, HARDWARE AND DETAILS.
- REFER TO SHEET A330 FOR WINDOW SCHEDULE AND DETAILS.
- PROVIDE BULLNOSE CORNER BEAD FOR ALL INTERIOR DRYWALL OUTSIDE CORNERS.

**SHEET NOTES**

- OPERABLE WALL PARTITION, WITH DOOR AND WINDOW. REFER TO SPECIFICATIONS.
- KNOX BOX KEY CABINET, MOUNT 48-INCHES ABOVE SLAB
- FIRE EXTINGUISHER CABINET
- 4'-0" WIDE GATE WITH PANIC HARDWARE"
- 6'-0" HIGH METAL PICKET FENCE"
- OWNER FURNISHED ACCESS CONTROL KEYPAD MOUNT 48" AFF
- OWNER FURNISHED COPIER.
- OWNER FURNISHED SMART BOARD, PROVIDE 20 GA METAL BACKING
- OWNER FURNISHED FLAT SCREEN, PROVIDE 20 GA METAL BACKING, VERIFY MOUNTING HEIGHT WITH OWNER.

**KEYNOTES**

NO.	DESCRIPTION
03 31 00 J1	4" CONCRETE SLAB (4,000 PSI) WITH 6 X 6 X W1.4 X W1.4 WWF, ON 10 MIL VAPOR BARRIER OVER TERMITRE TREATED COMPACTED FILL (TYP.)
04 22 00 A16	8" CONCRETE MASONRY UNIT WITH HORIZONTAL REINFORCING AT 16" O.C.
05 12 00 J1	STEEL TUBE - SEE STRUCTURAL
05 41 00 A5	3-5/8" METAL STUD - SEE STRUCTURAL
05 41 00 B7	CONT. STEEL TRACK
06 16 43	GYPSUM SHEATHING
07 24 00 A2	EIFS WALL BASE WITH BEVELED TOP
07 25 00	WEATHER BARRIERS
07 62 00 G3	4" X 4" RECTANGULAR RAIN LEADER
07 92 00	JOINT SEALANTS
09 22 36 B2	CEMENT PLASTER CORNER BEAD - SEE SPECIFICATIONS
09 24 00 A1	CEMENT PLASTER - SEE SPECIFICATIONS
09 30 13 A2	CERAMIC TILE

**FINISH NARRATIVE**

FINISH MARK	FINISH / MATERIAL	REMARKS
10	CONC. SEALER	-
11	CARPET TILE	INTERFACEFLOR LLC, CUBIC LINE-COLOR: AREA-4292, 52 CM X 52 CM
12	LVT	MANNINGTON, SPACIA-WOOD, COLOR:WEATHERED OAK -S5W2524, 4" X 36"
13	QUARRY TILE	CROSSVILLE, METROPOLITAN CERAMIC, COLOR 505 PLAZA GRAY, 8" X 8"
21	4" VINYL COVE BASE	JOHNSONITE, COLOR: MIDNIGHT-83
22	QUARRY TILE COVE BASE	CROSSVILLE, METROPOLITAN CERAMIC, COLOR 505 PLAZA GRAY, 8" X 8"
31	PAINT	MATCH DURON, COLOR: BLUE CHILL-7050W
32	PAINT	MATCH DURON, COLOR: ICED ORCHID-7470W
33	PAINT	MATCH DURON, COLOR: POMPEII-7055D
34	PAINT	MATCH DURON, COLOR: WILD ORCHID-7475D
35	PAINT	SHERWIN WILLIAMS COLOR: SW7007-CEILING BRIGHT WHITE
39	FRP	MARLITE COLOR: P151 LIGHT GREY, CLASS A

- INTERIOR PAINT SCHEDULE:**
- CMU SUBSTRATES: PRE-CATALYZED WATER BASED EPOXY, SEMI GLOSS FINISH.
  - METAL SUBSTRATES: WATER BASED ALKYD URETHANE, SEMI GLOSS FINISH.
  - WOOD SUBSTRATES: WATER BASED ALKYD URETHANE, SEMI GLOSS FINISH.
  - GYPSUM BOARD SUBSTRATES (ACCEPT CEILING): PRE-CATALYZED WATER BASED EPOXY, EGGSHELL FINISH.
  - GYPSUM BOARD CEILING: LAYTEX WATER BASED, FLAT FINISH.
- REFER TO SPECIFICATIONS FOR PRIMERS AND PAINT PRODUCTS.

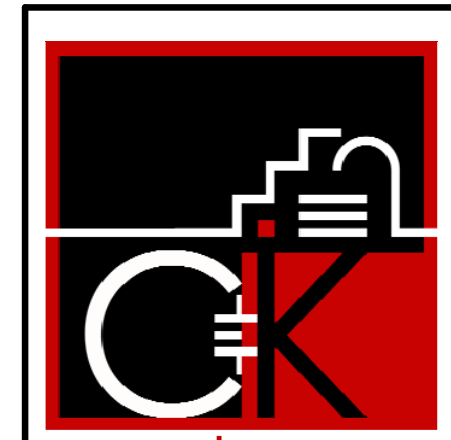

**ARCHITECTS INTERIORS, INC.**  
architects-interiors design-build services  
AACC011472

4301 Anchor Plaza Parkway, Ste 100  
Tampa, FL 33634-7525  
813.884.2000

280 West Central Avenue  
Winter Haven, FL 33880-2957  
863.577.2054

BRYAN L. KARSKY

DESCRIPTION

NO. DATE BY

CONSTRUCTION DOCUMENTS  
**FIRST FLOOR PLAN**  
DAYCARE FACILITY FOR  
**CREATIVE WORLD SCHOOL**  
VANDERBILT BEACH RD.  
NAPLES, FL

ISSUED FOR:  
PROJECT NUMBER:  
15098  
DATE:  
9.21.2018  
DRAWING NUMBER:  
**A300**

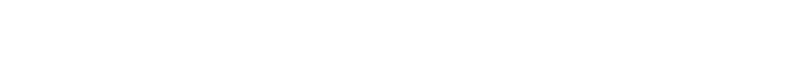
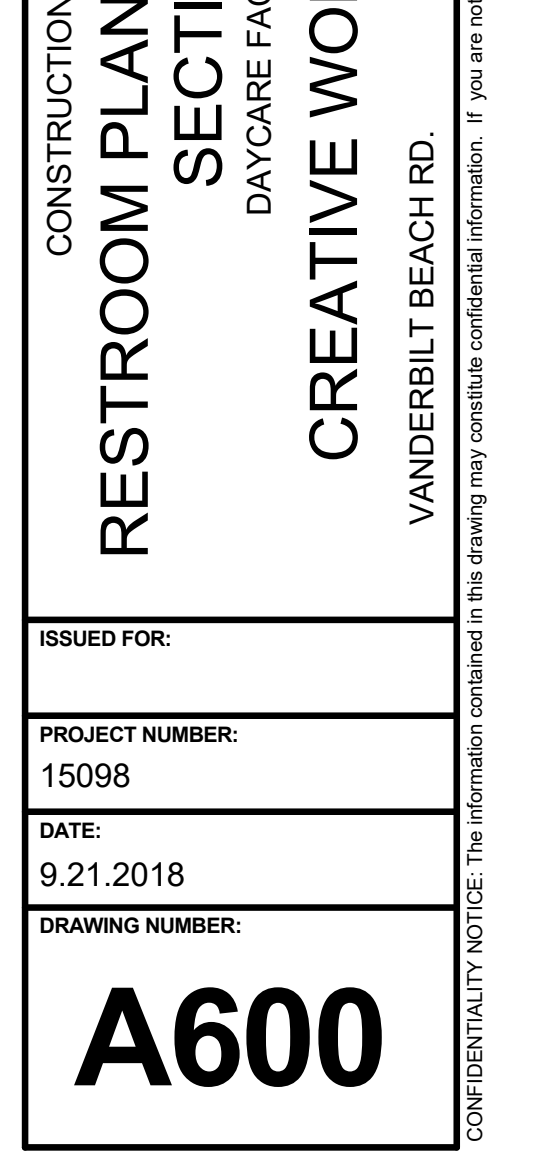
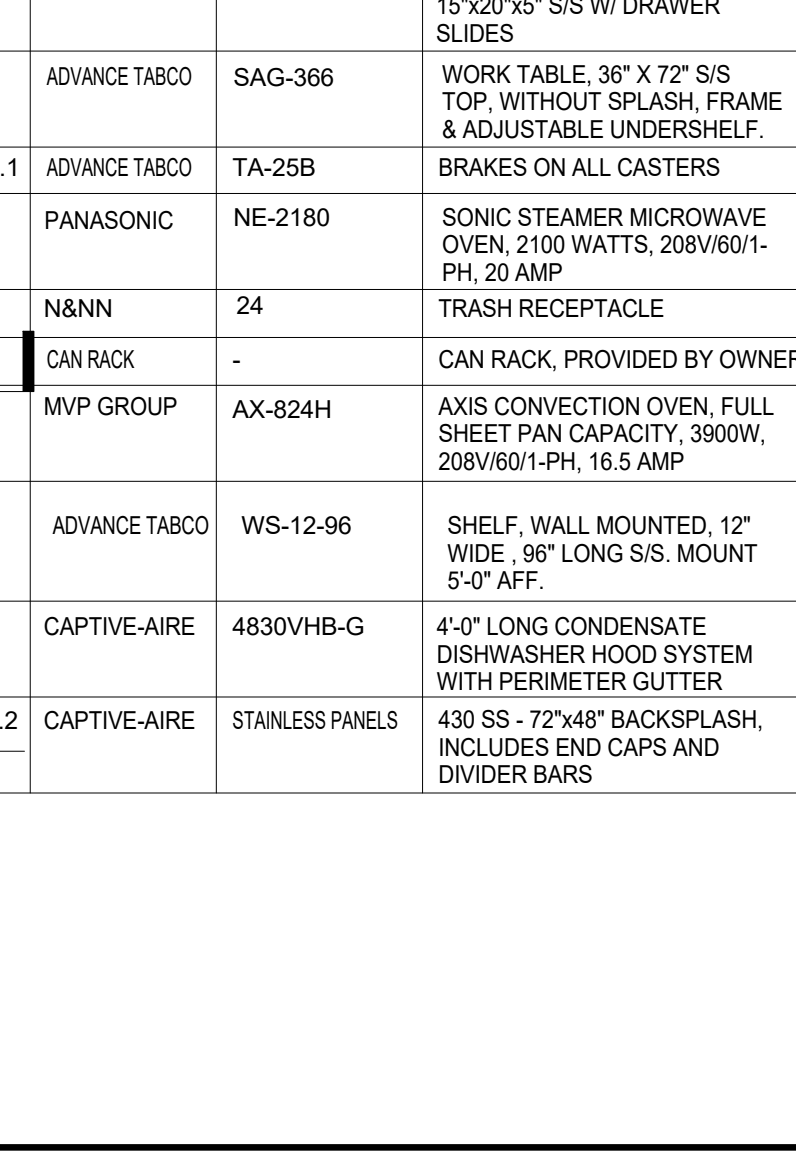
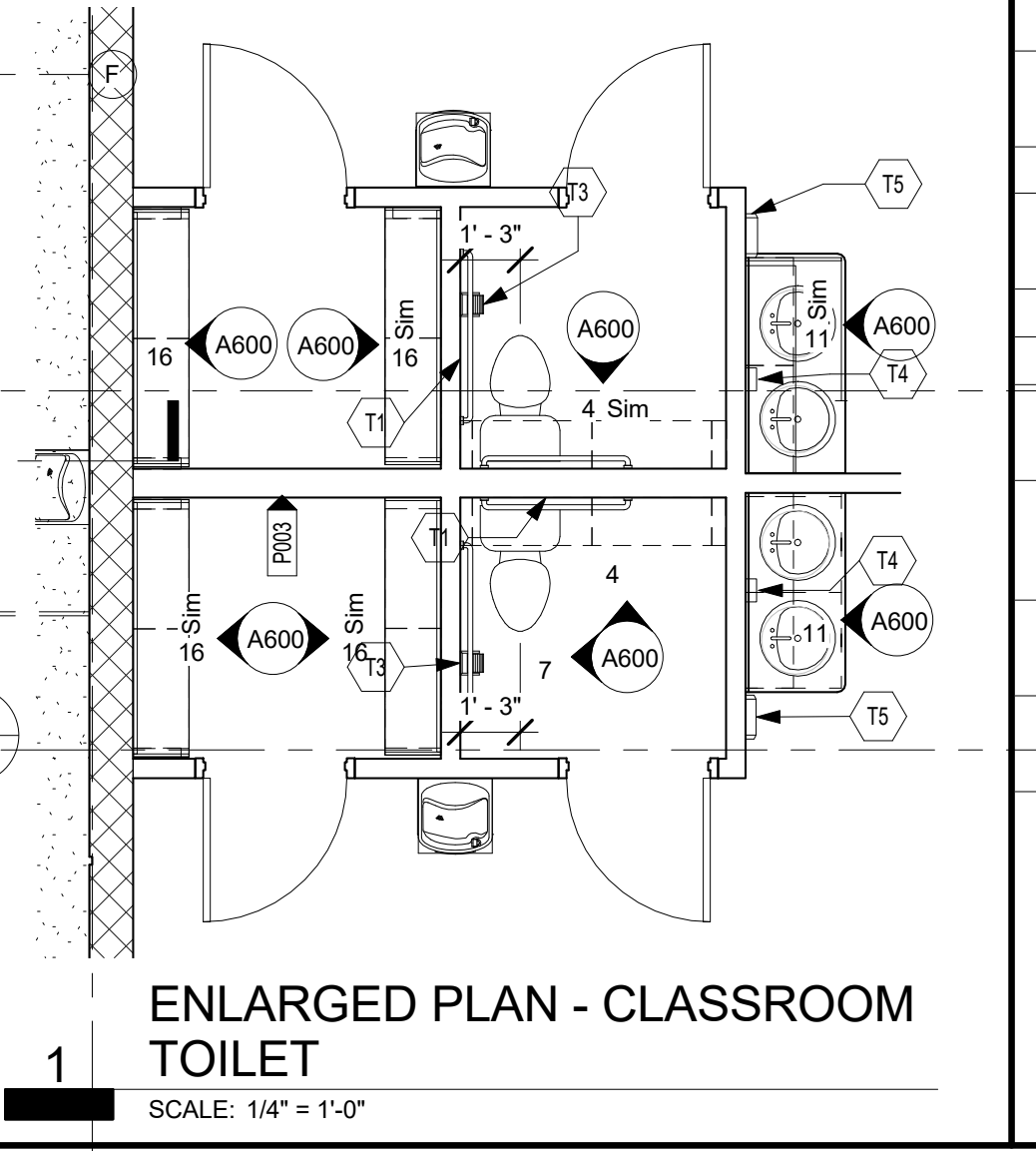
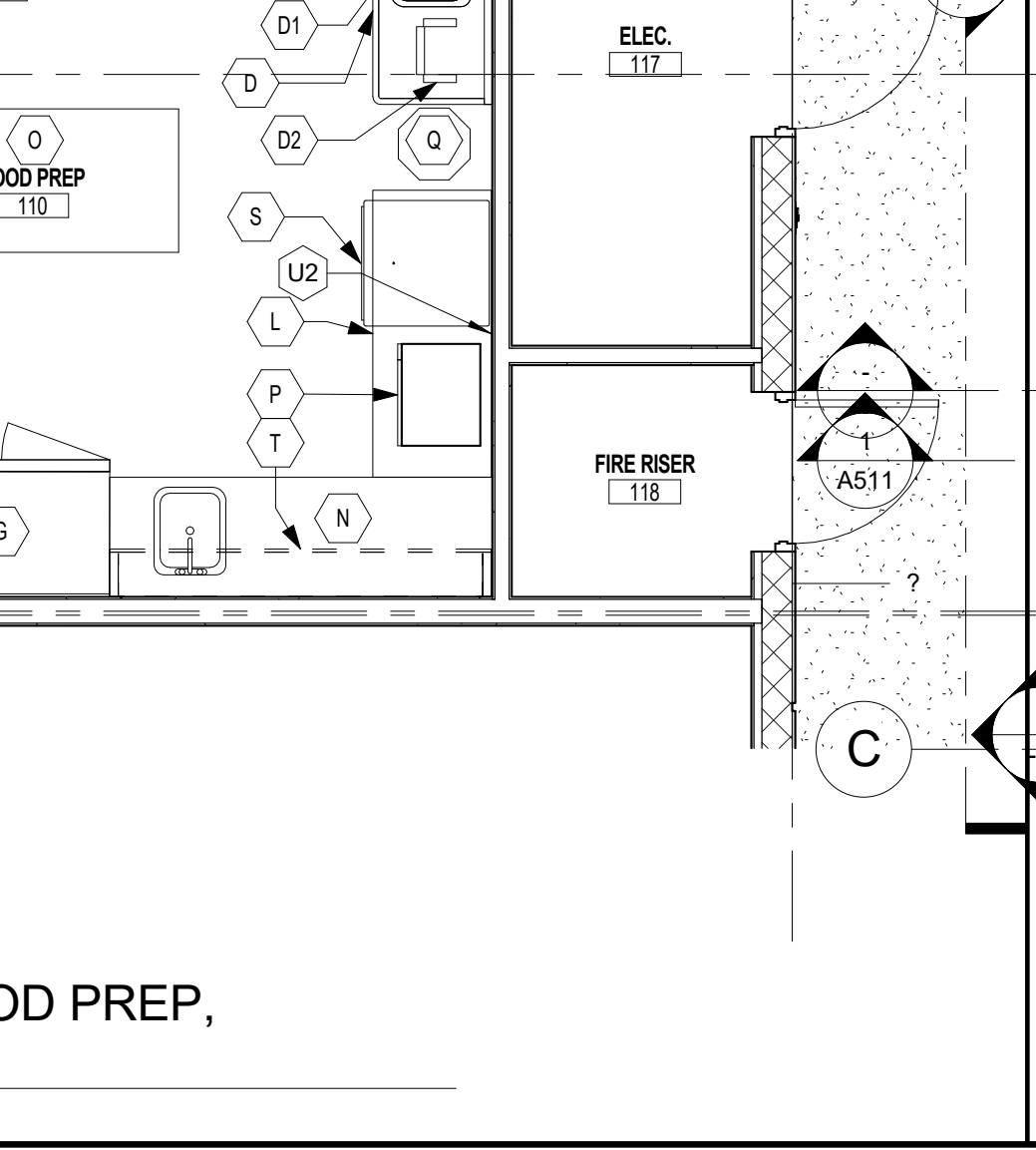
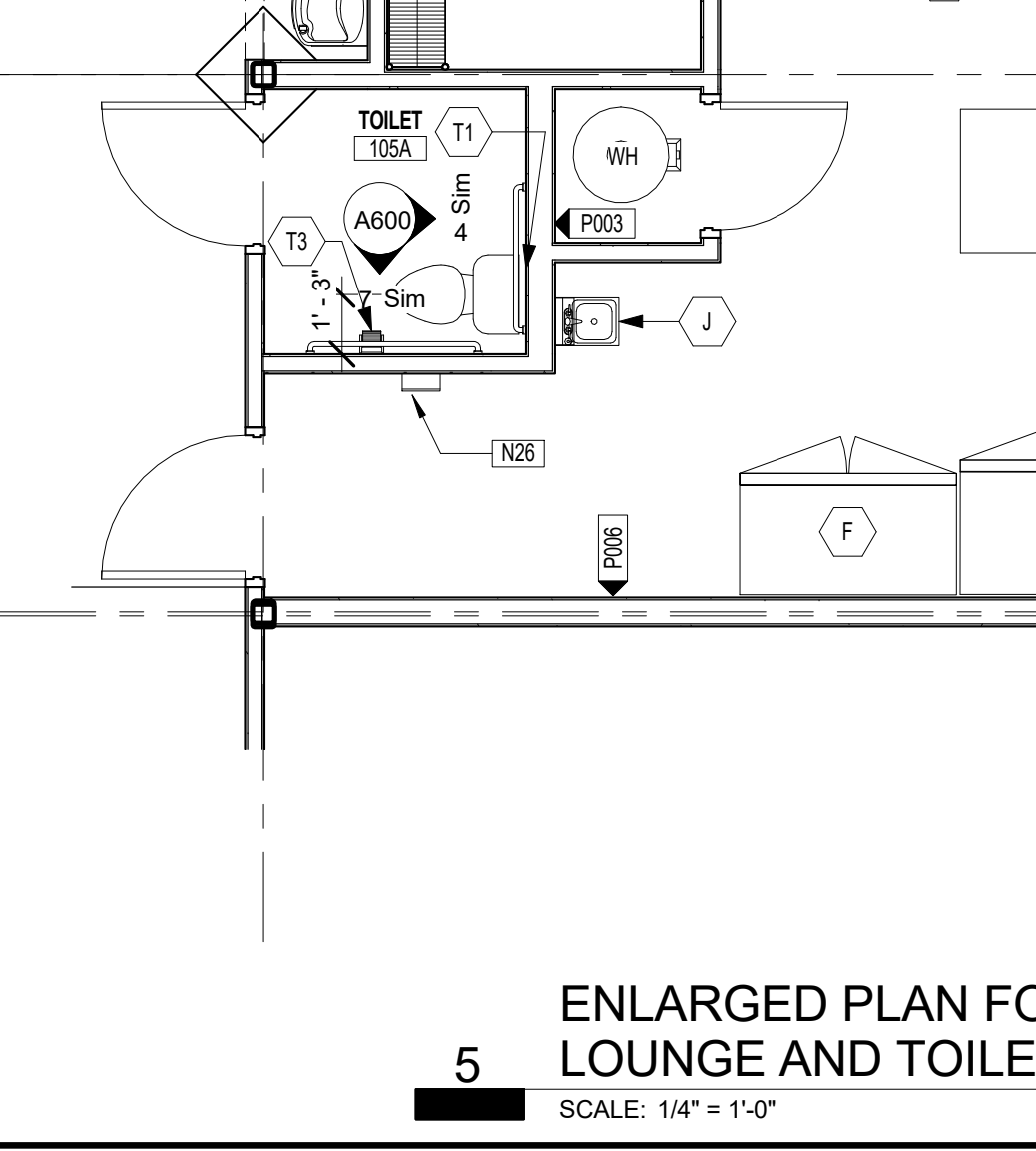
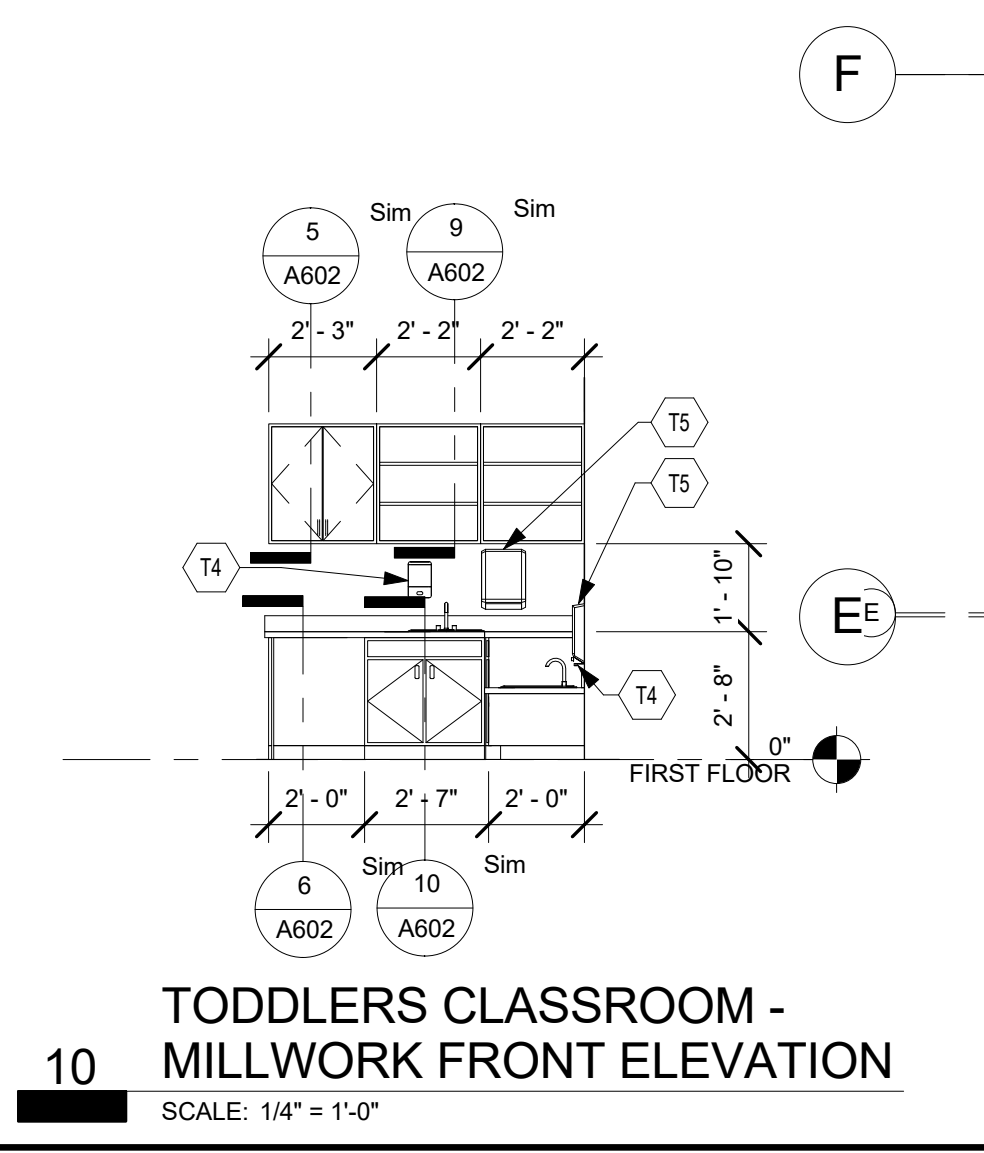
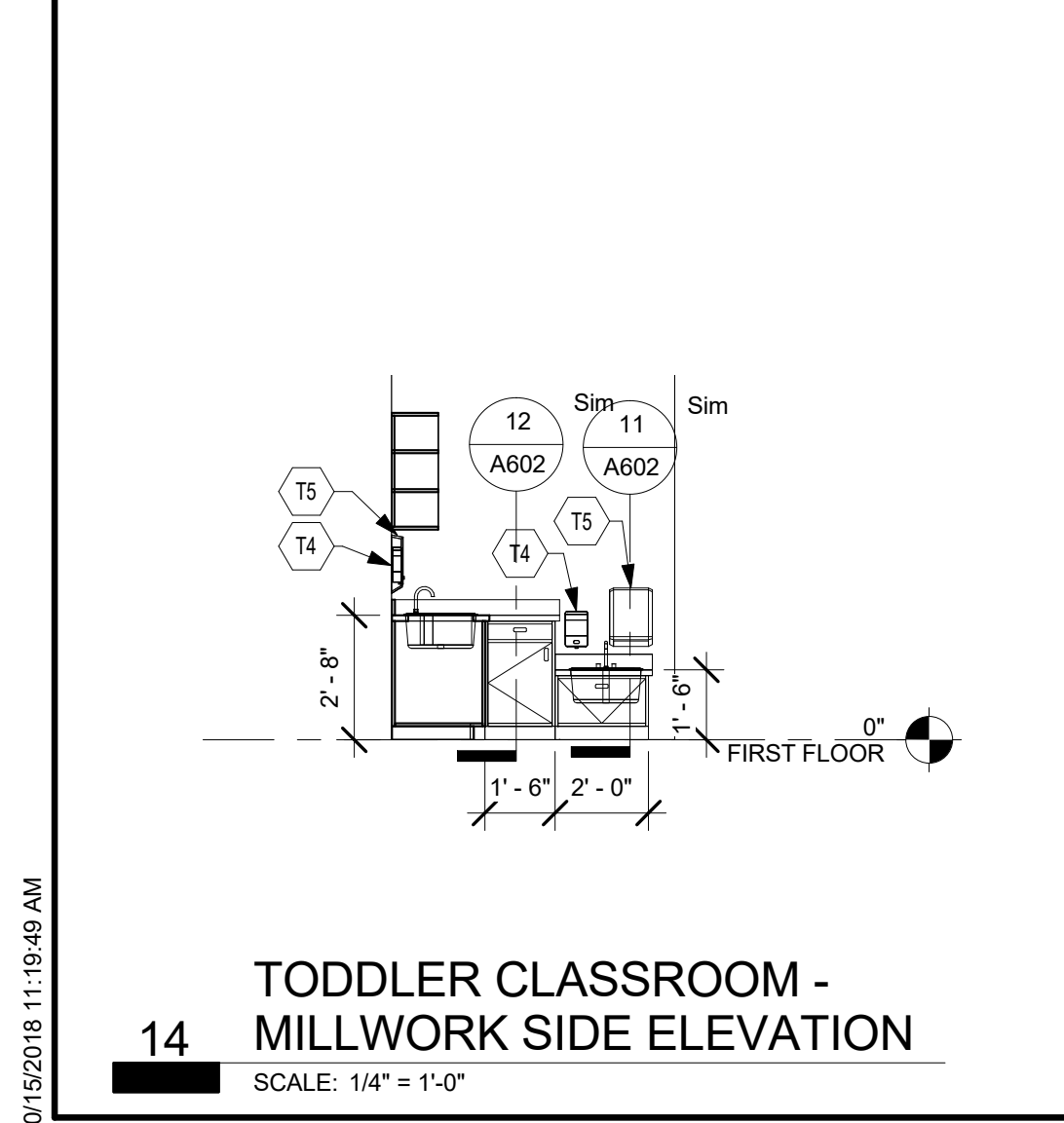
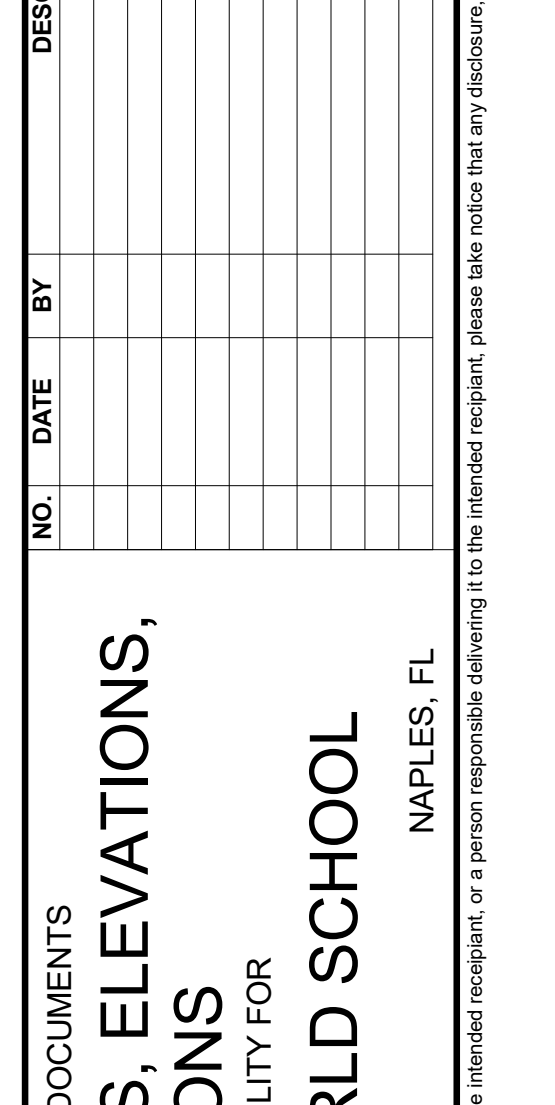
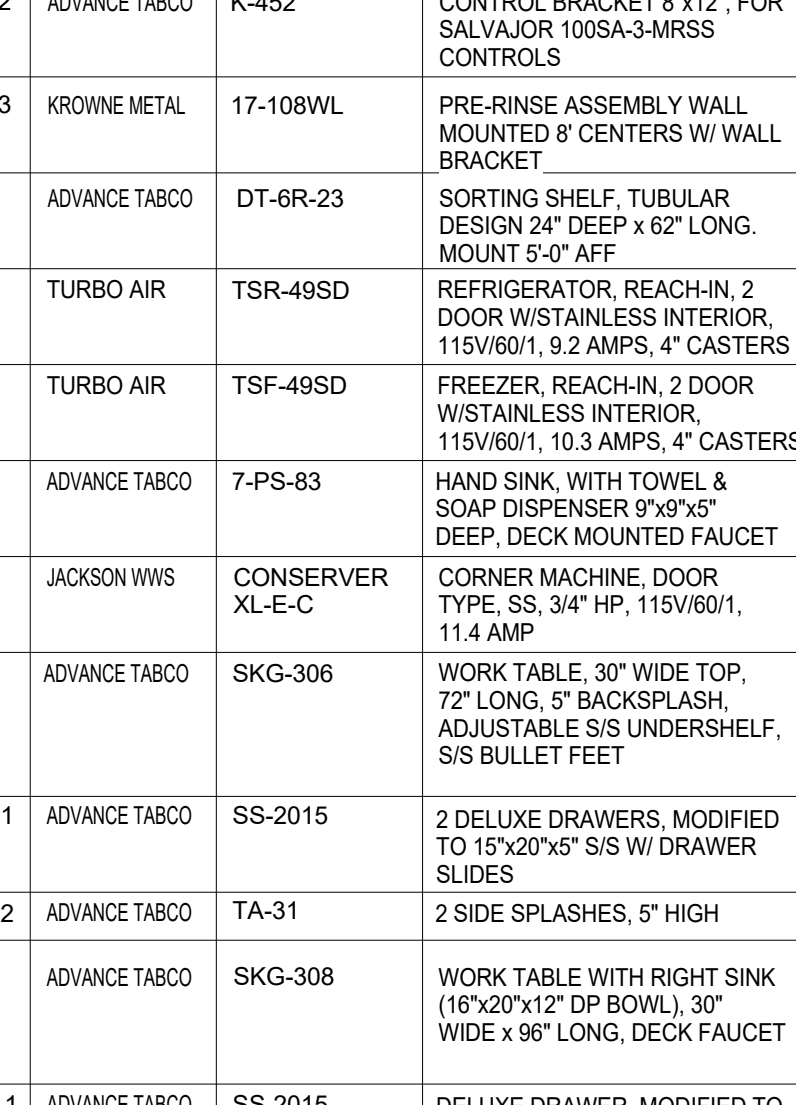
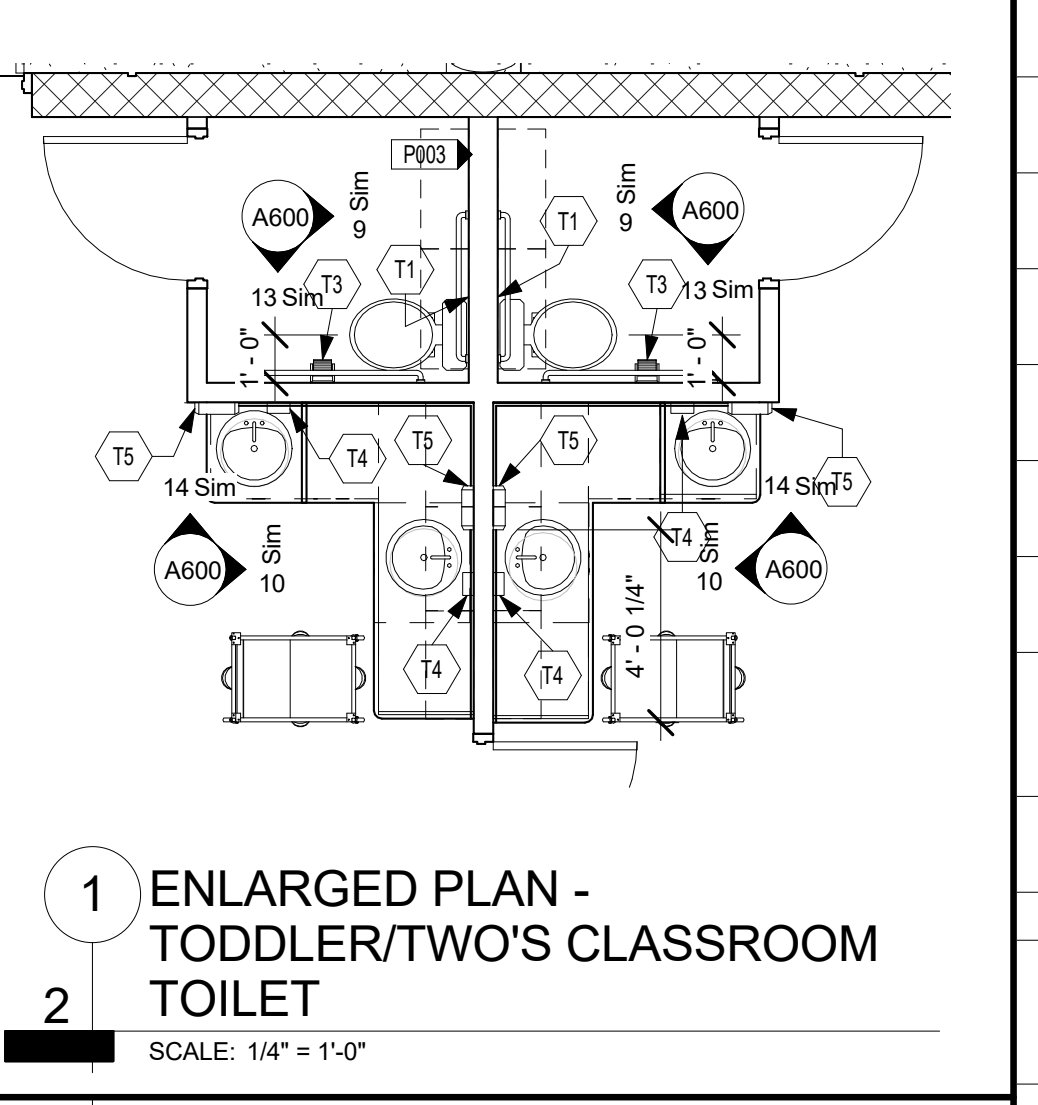
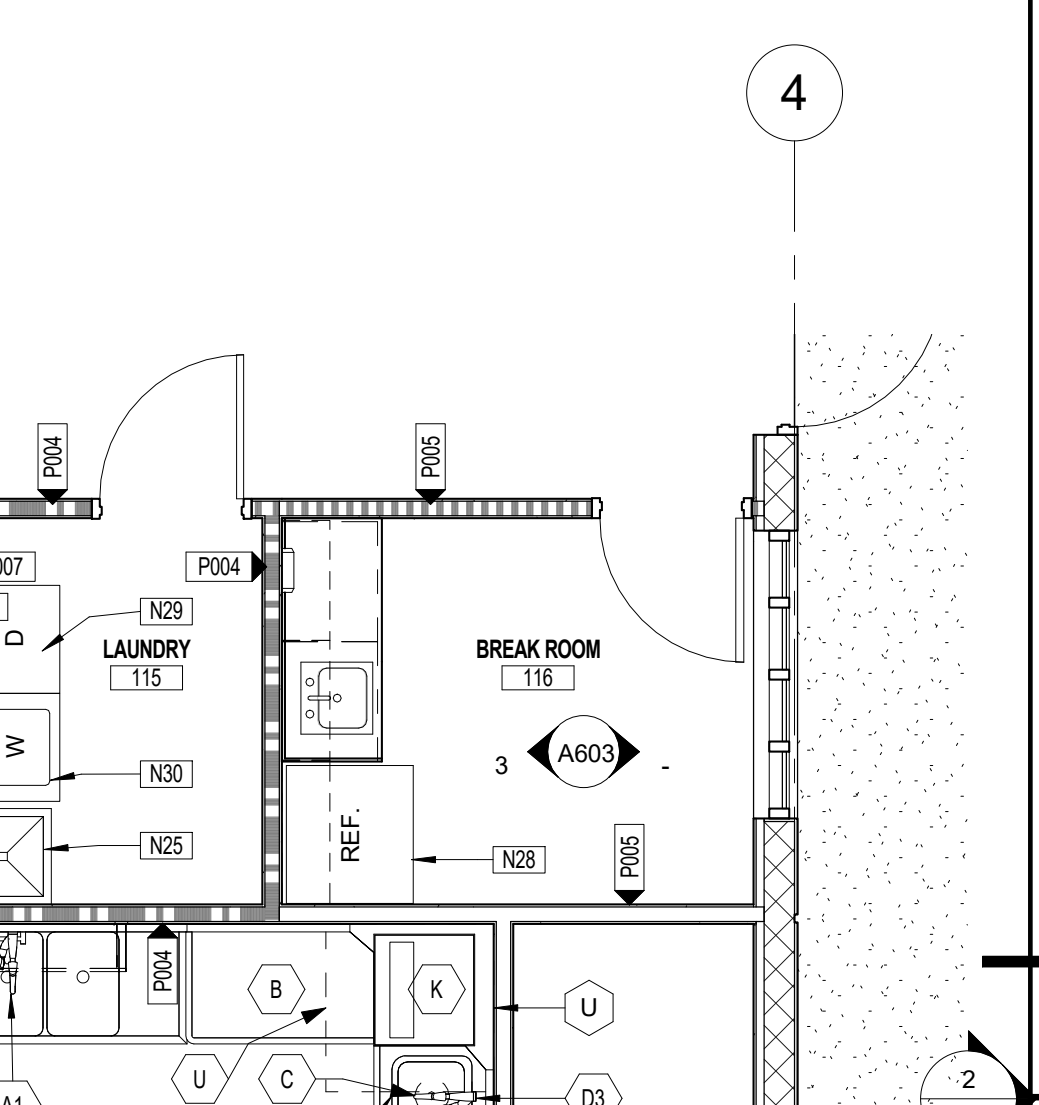
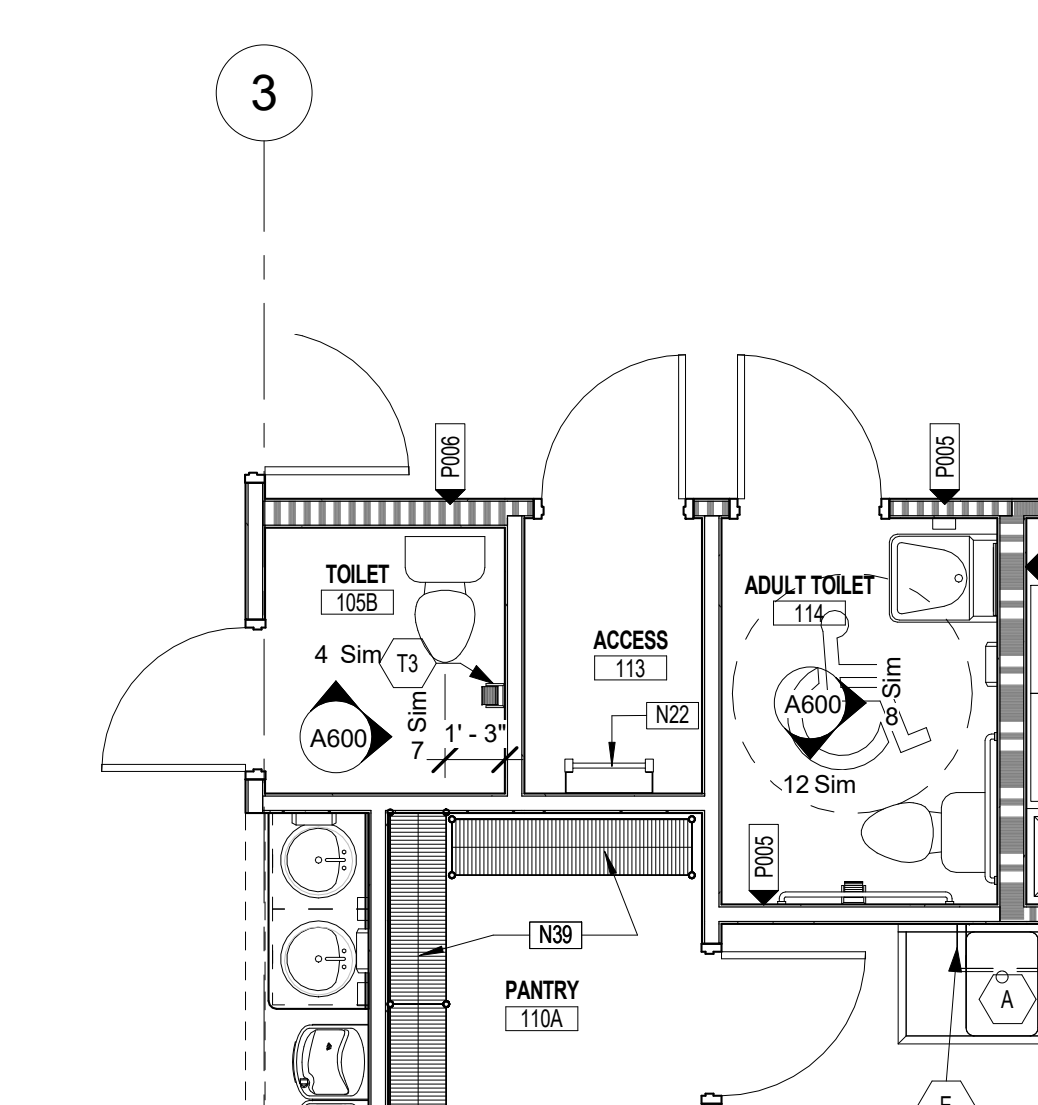
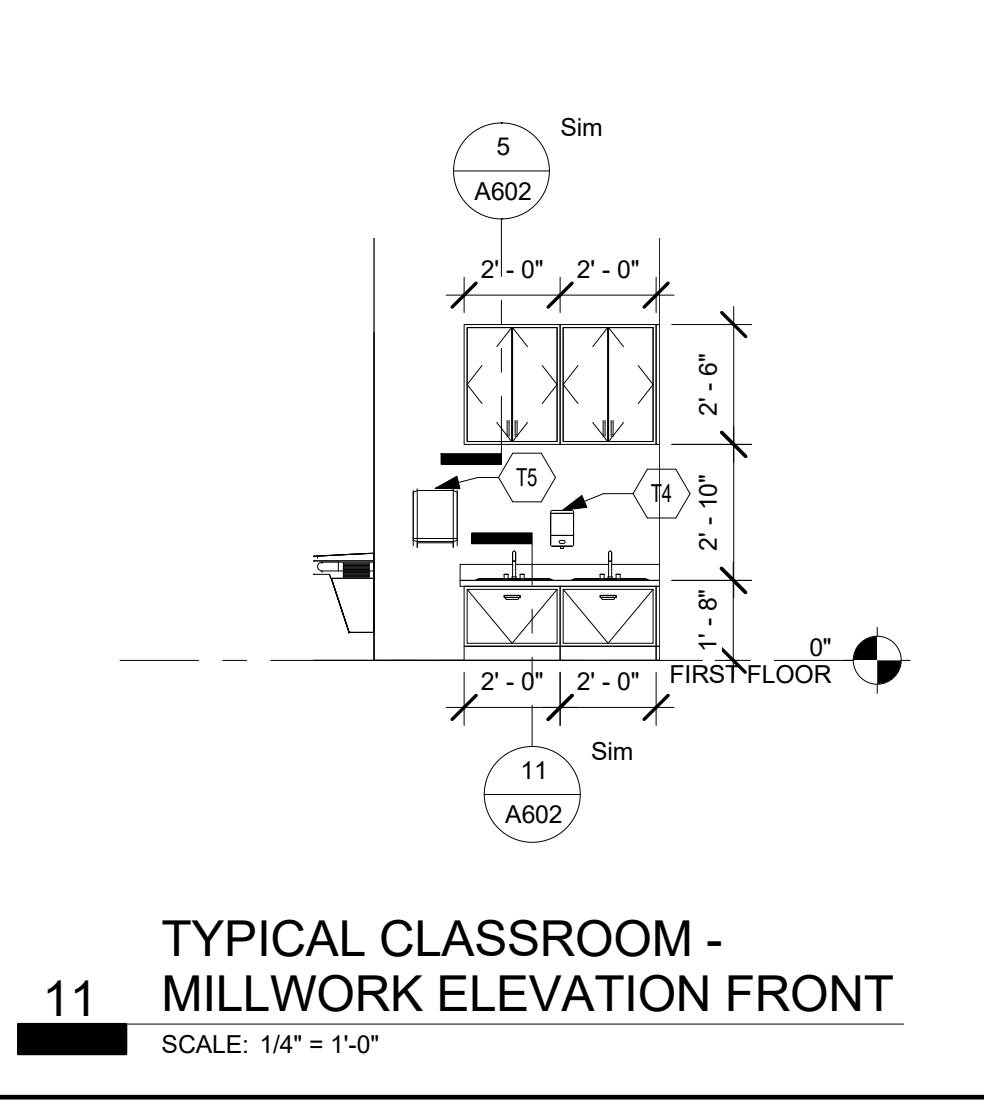
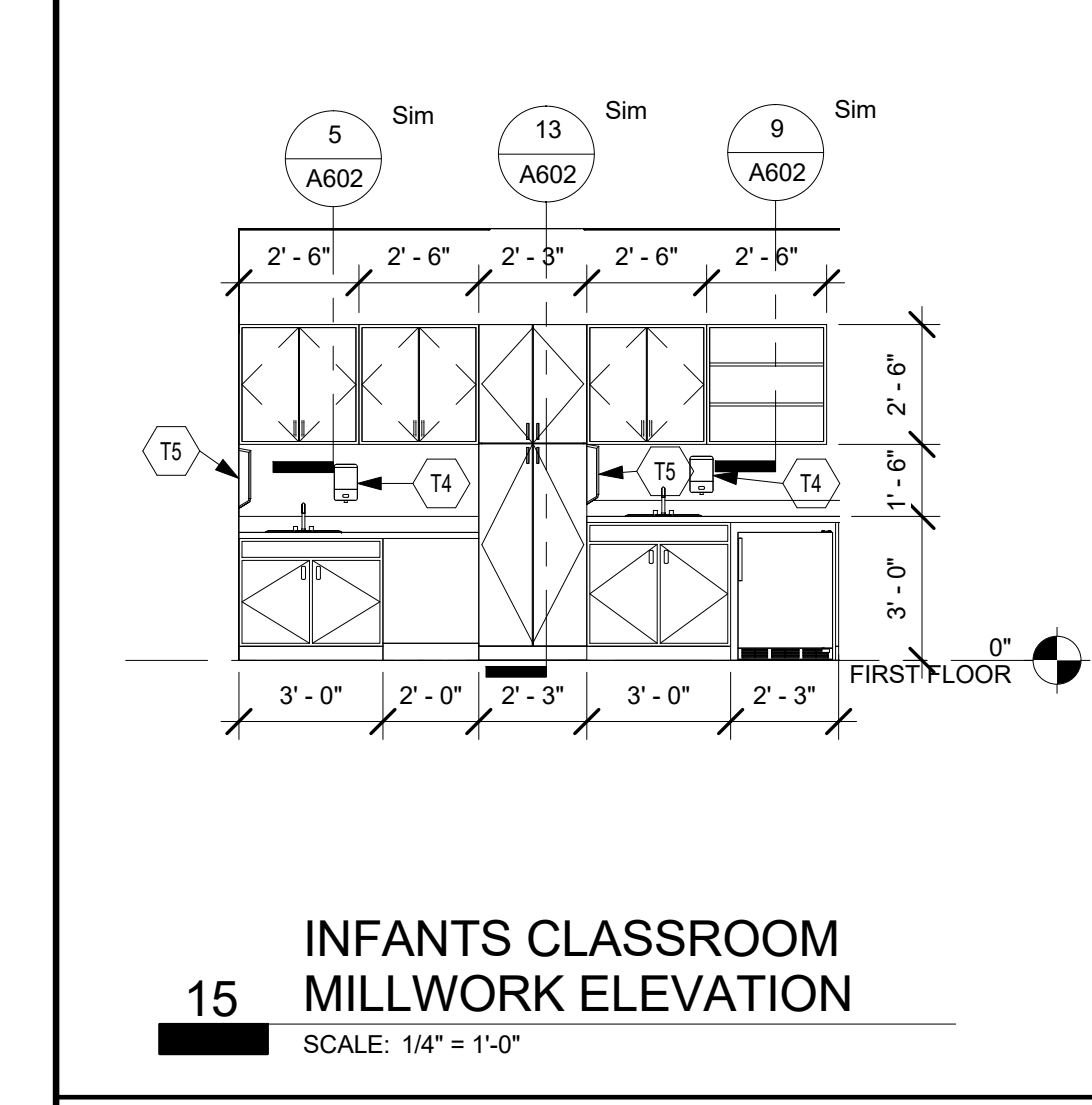
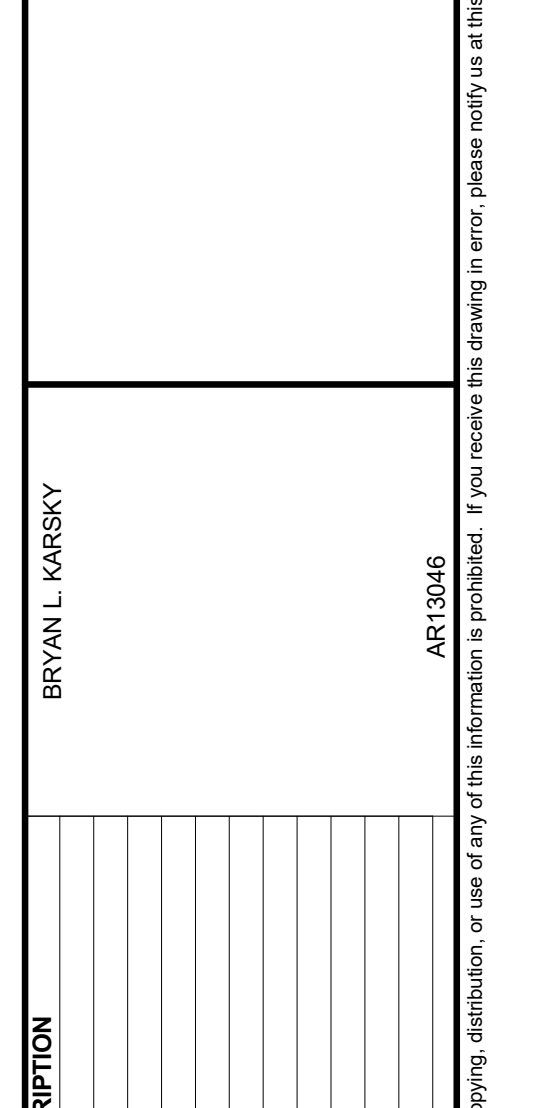
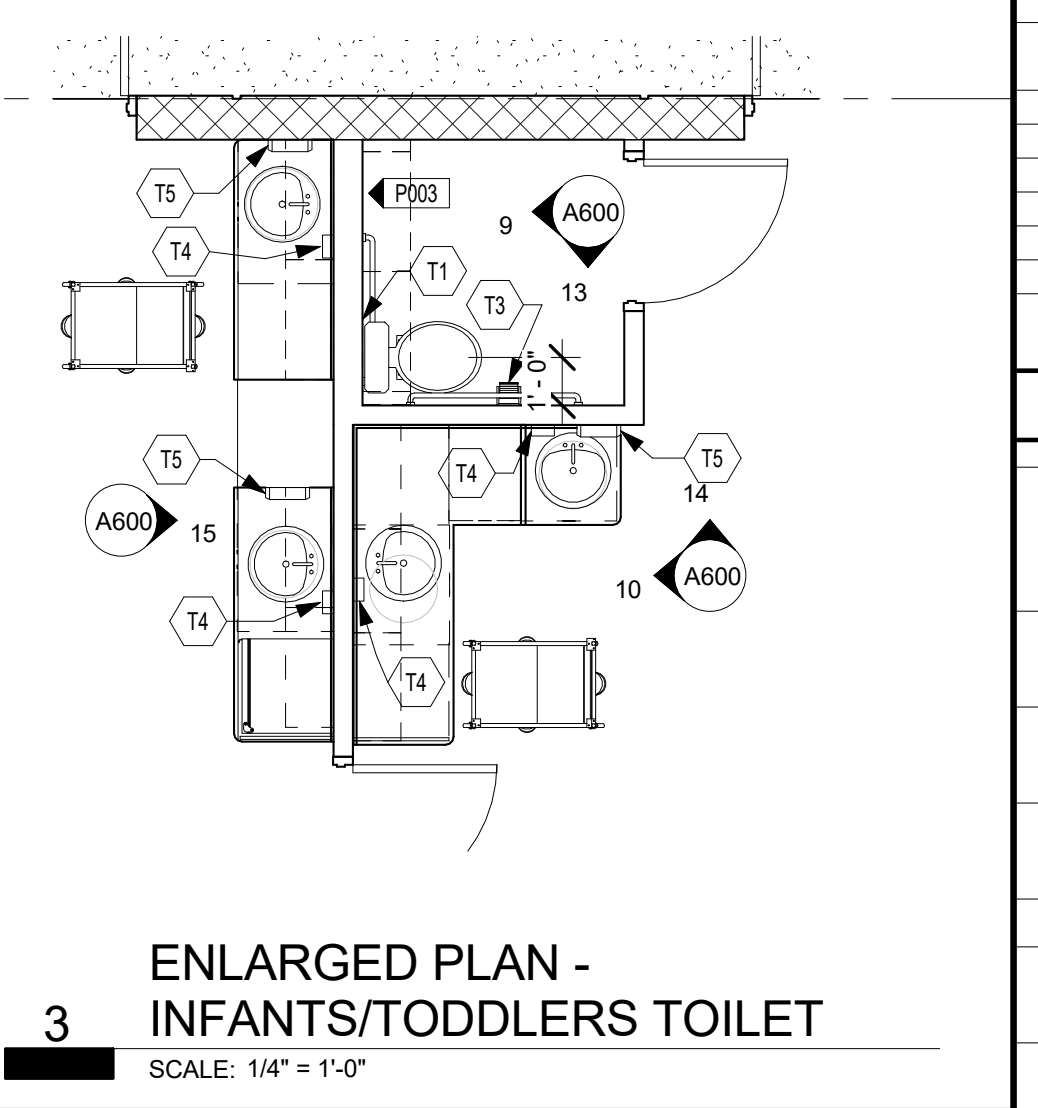
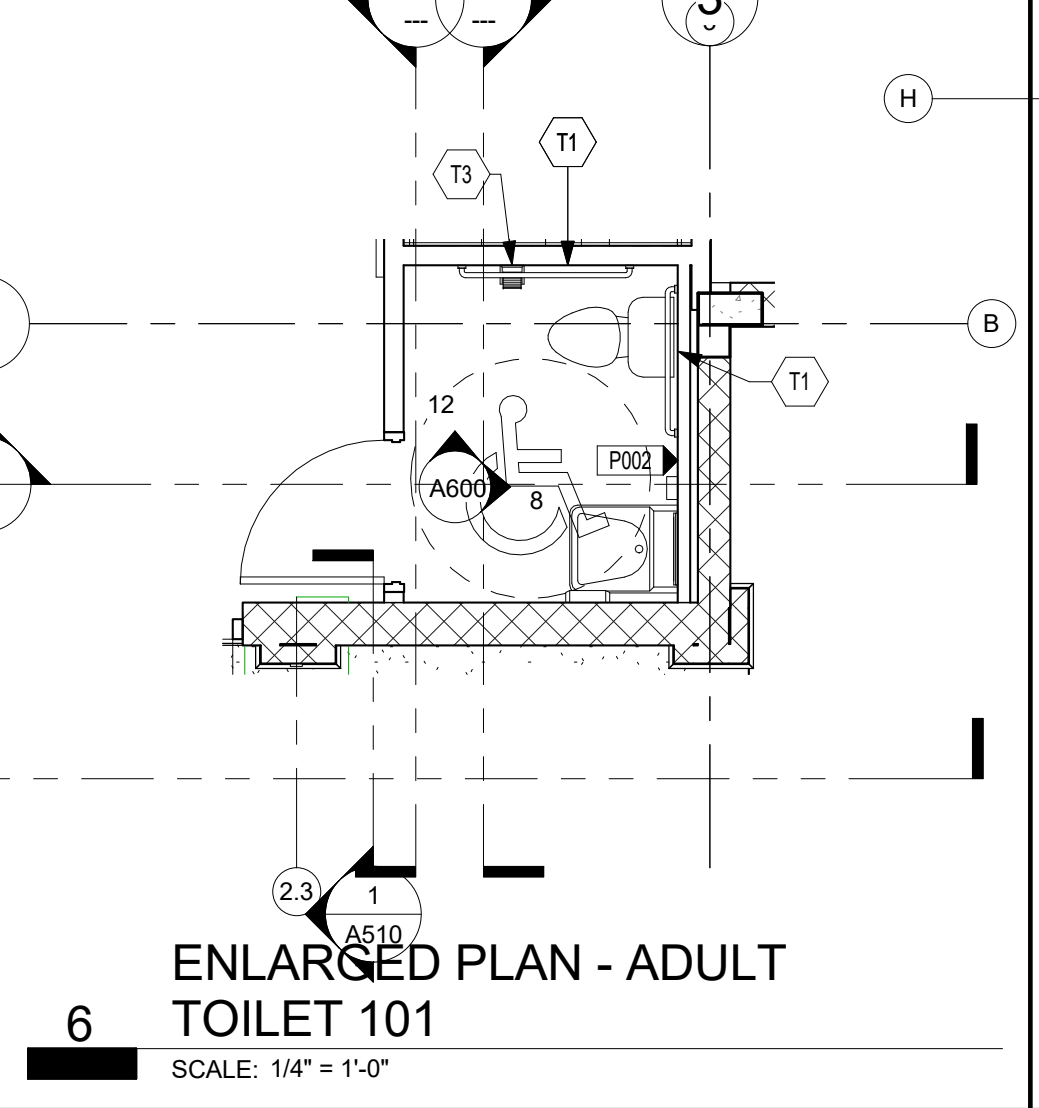
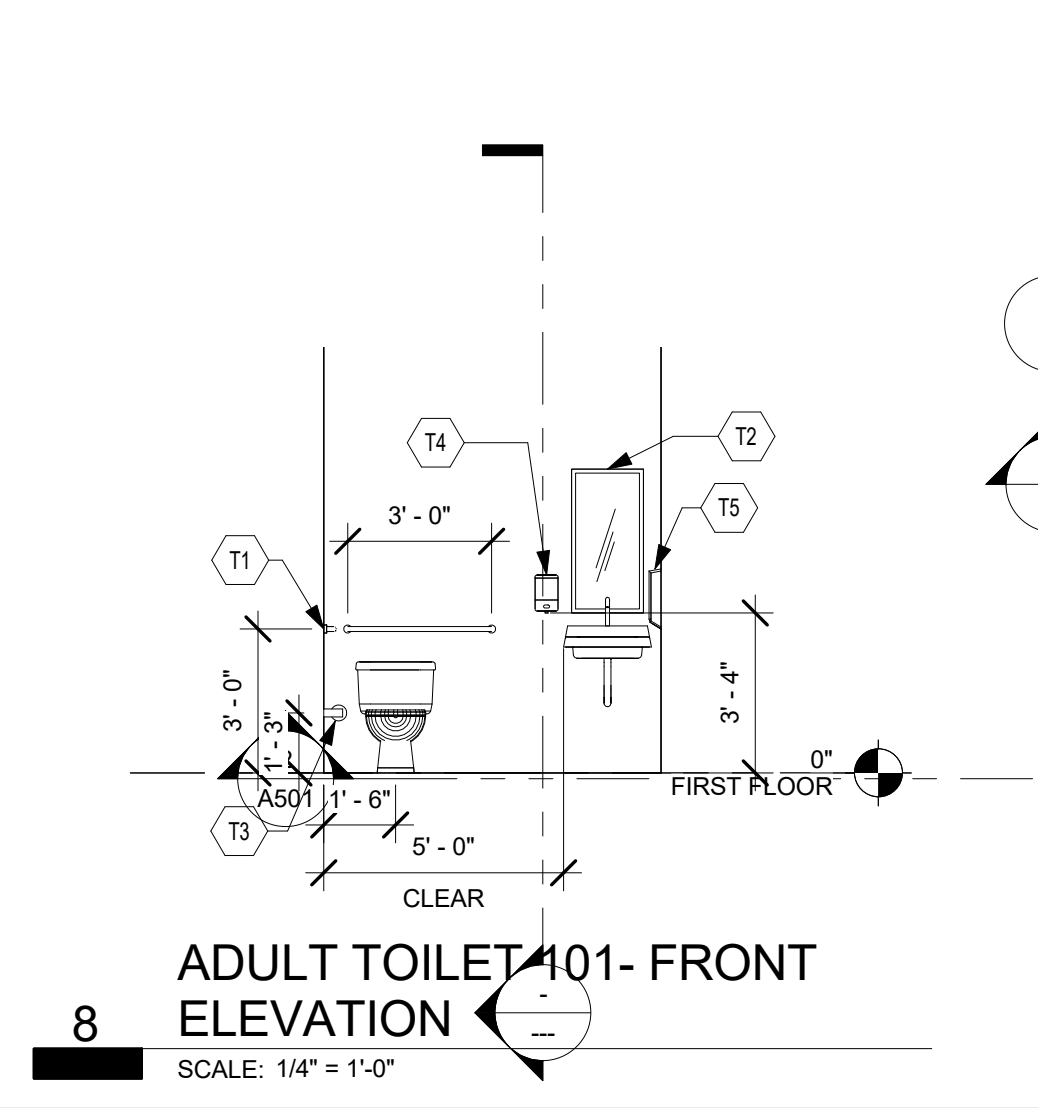
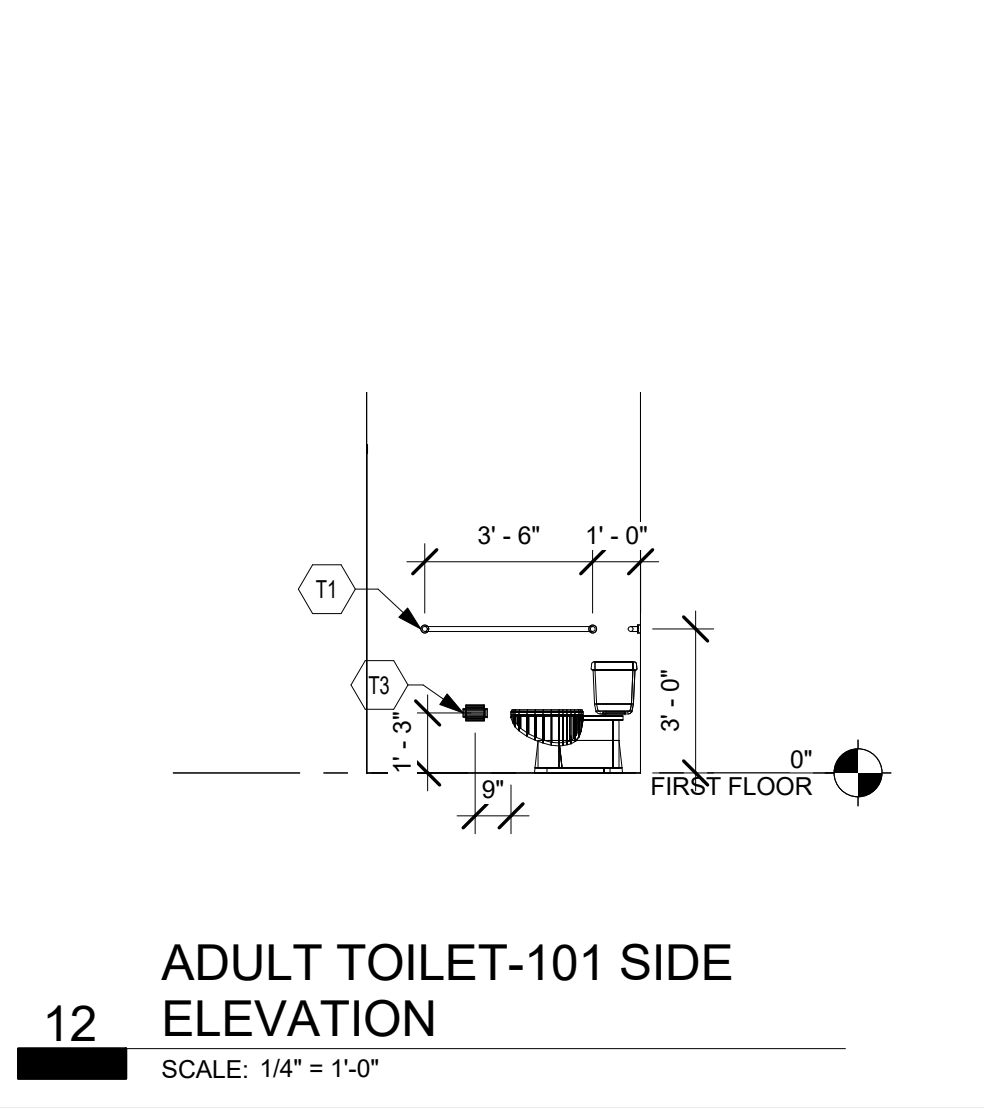
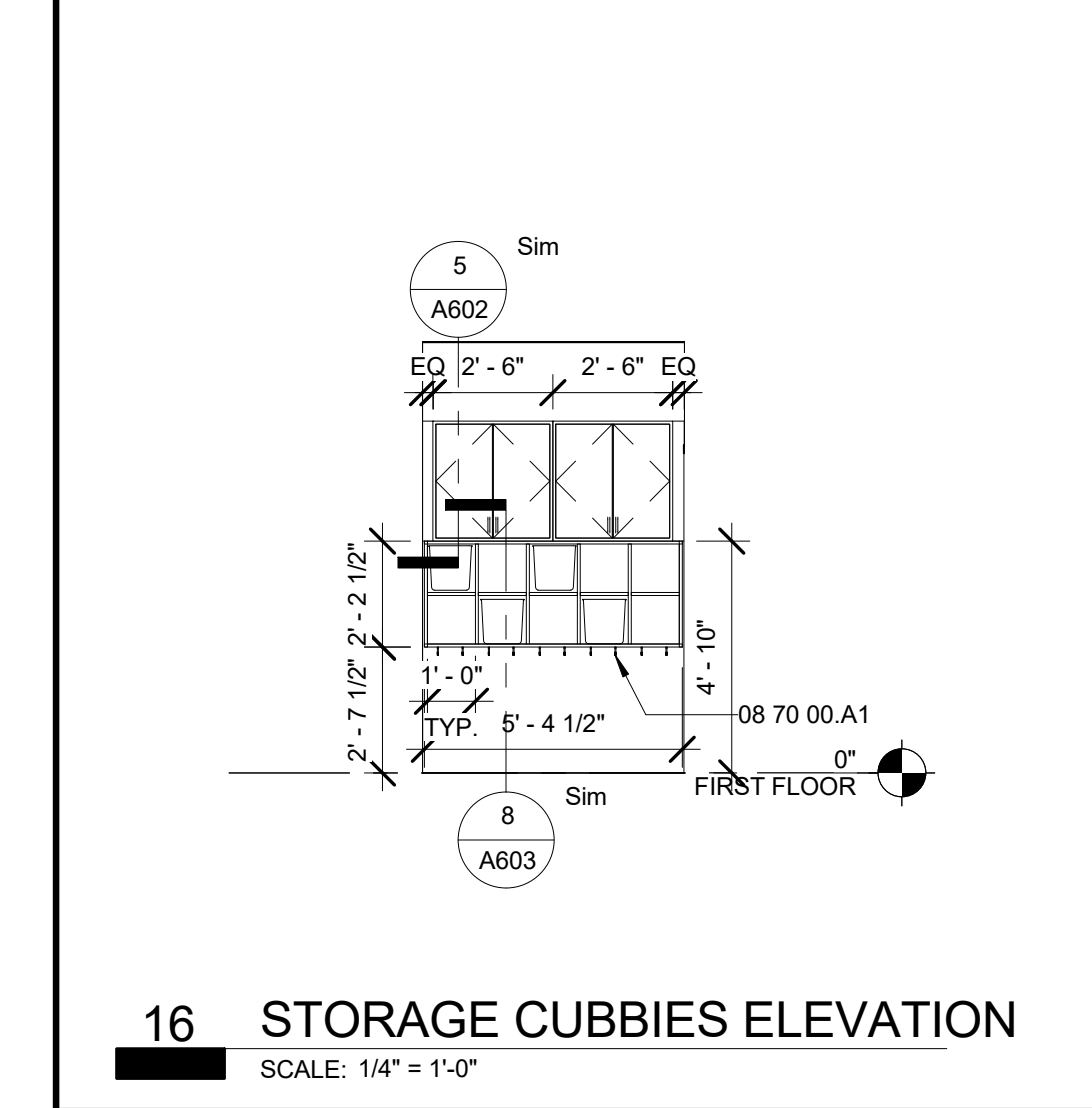
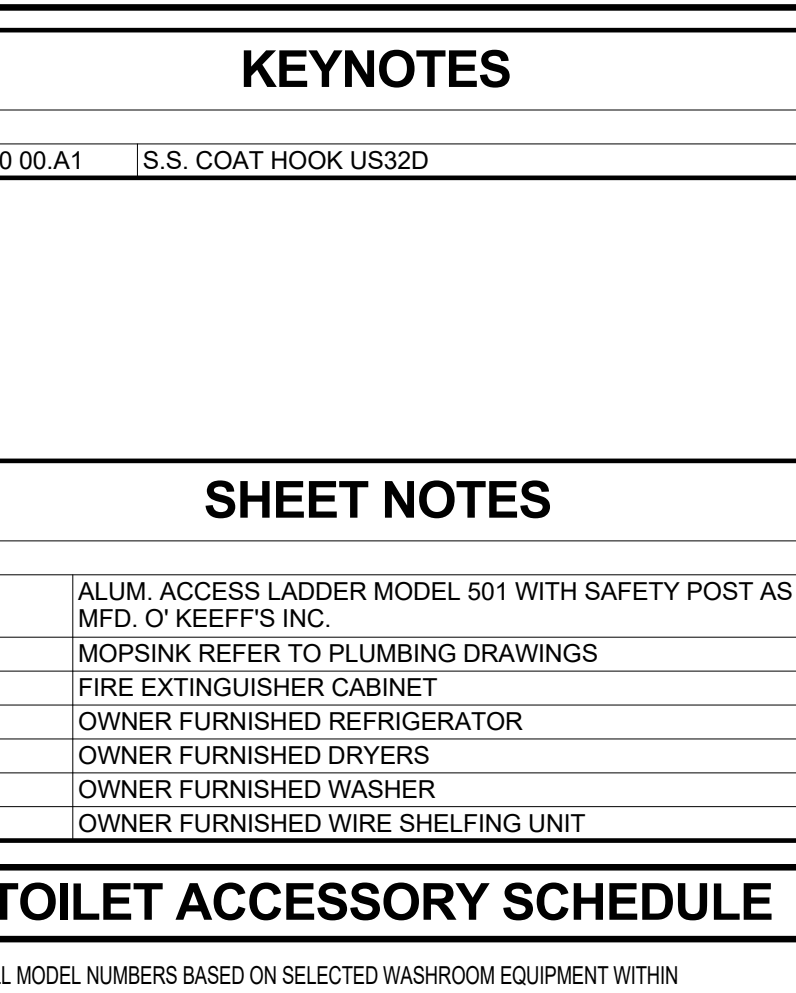
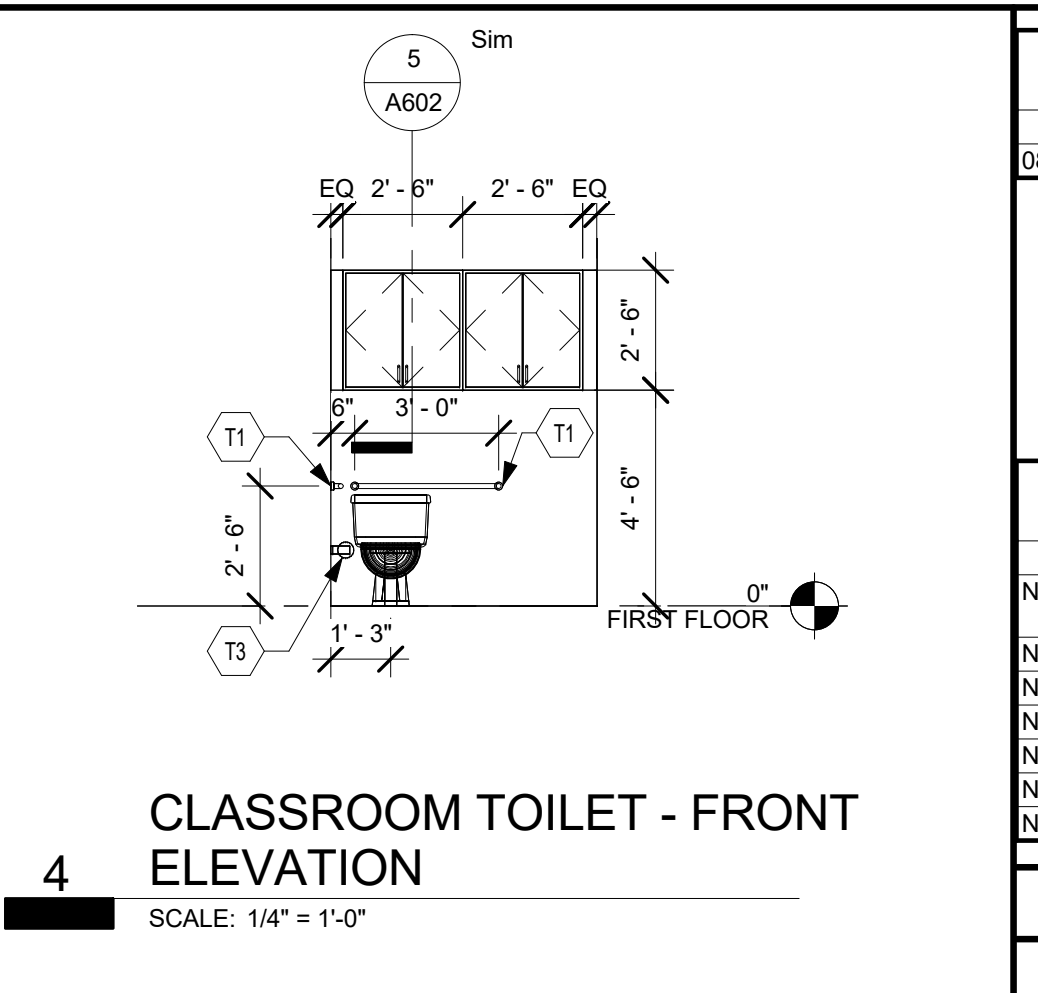
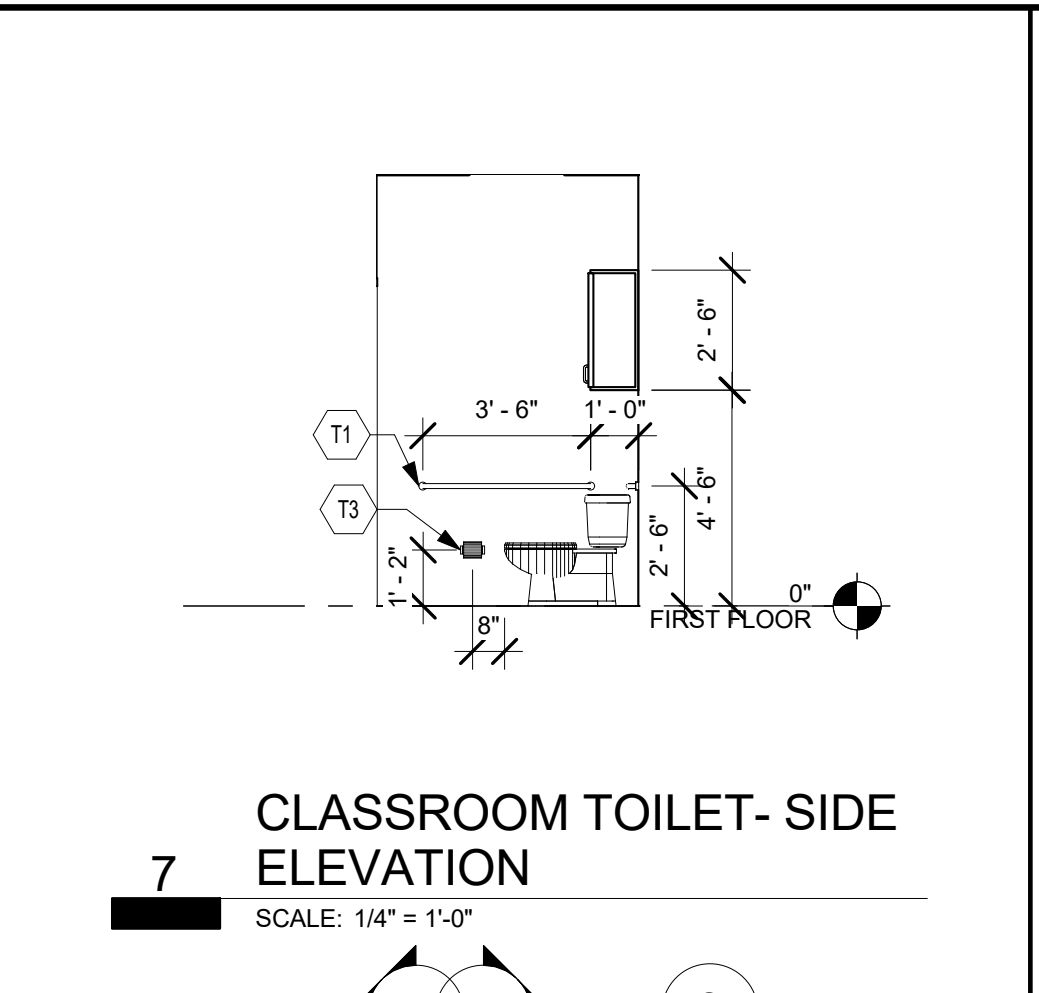
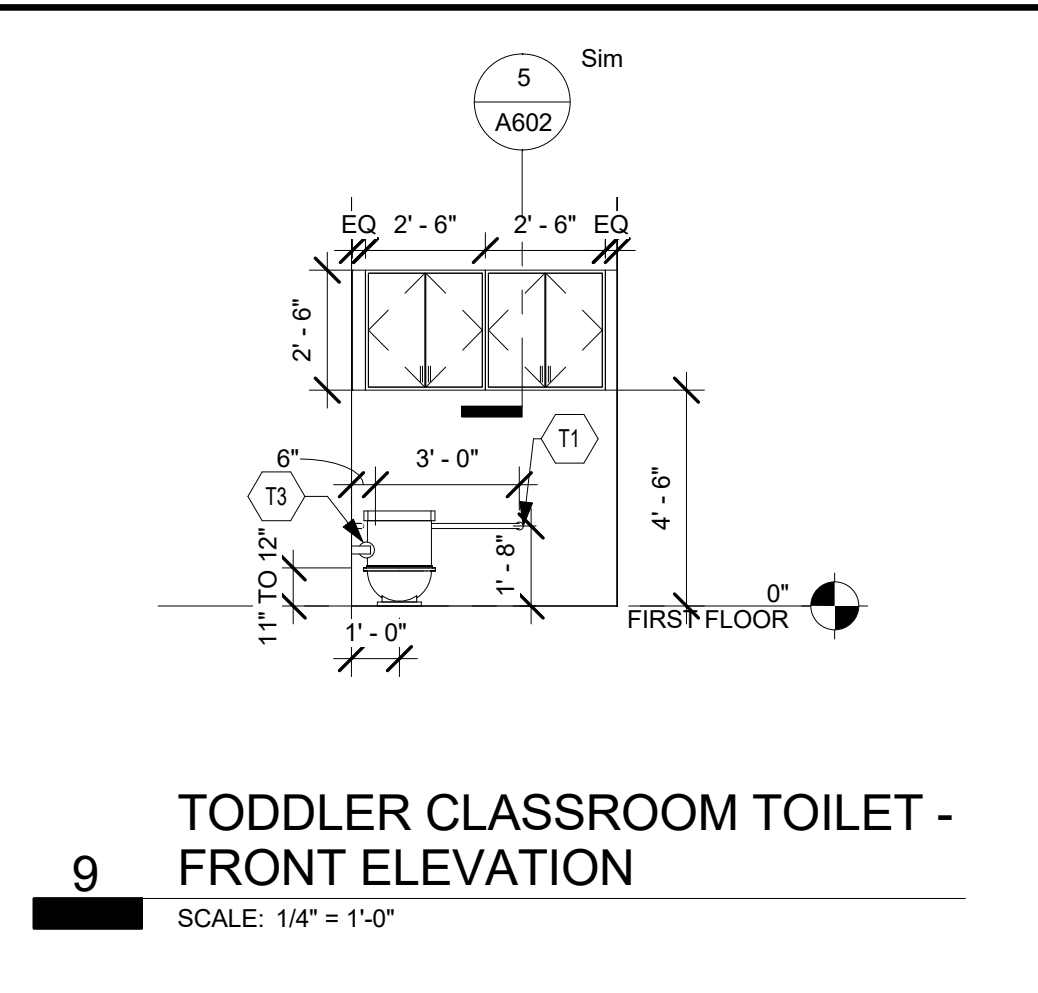
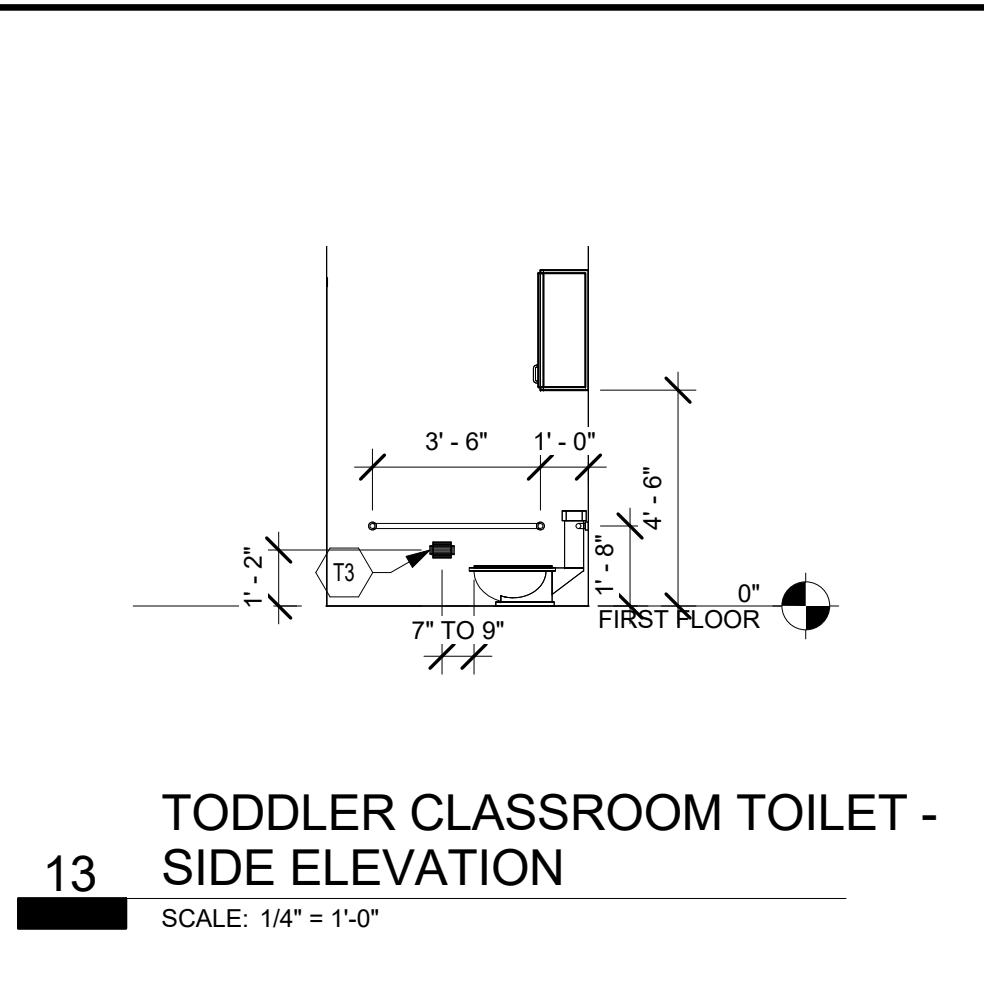
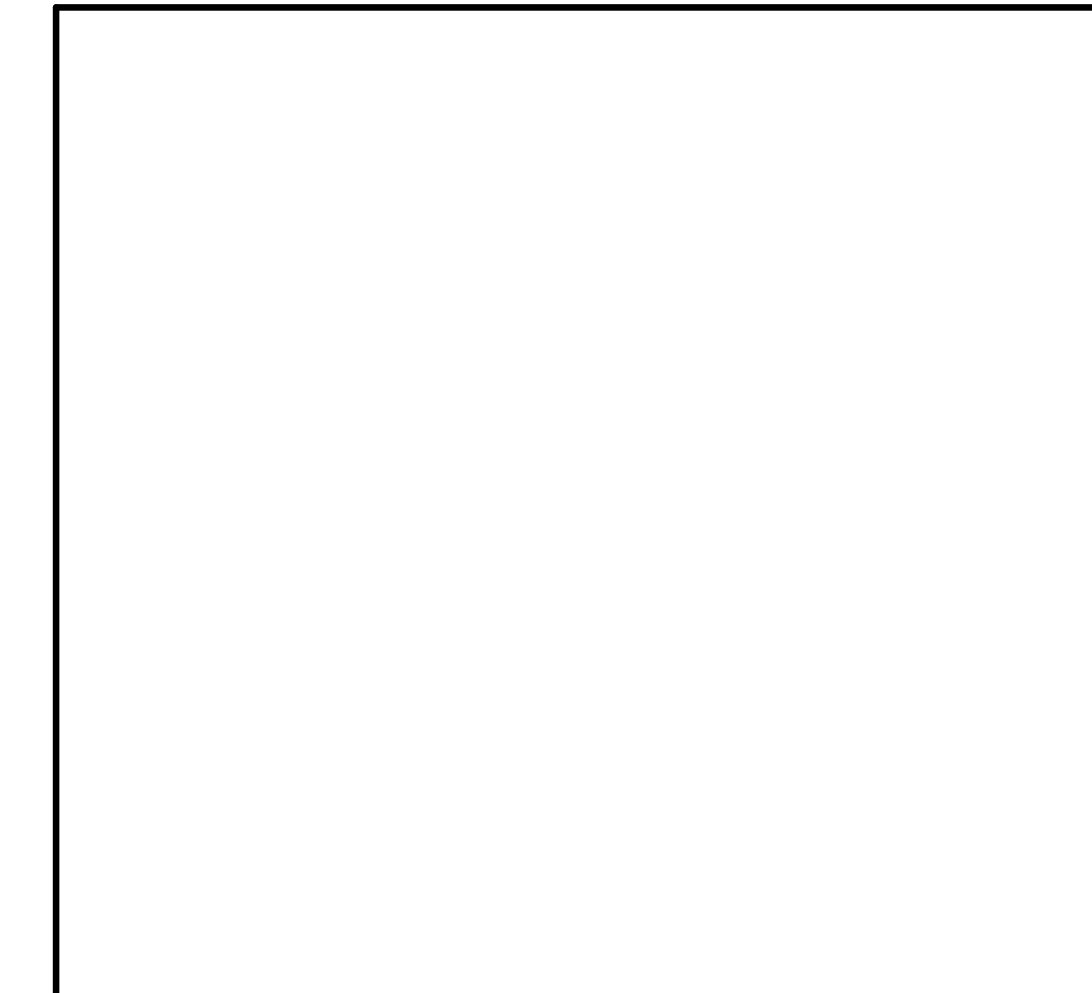

**KEYNOTES**

08 70 00.A1 S.S. COAT HOOK US32D

**SHEET NOTES**

- N22 ALUM. ACCESS LADDER MODEL 501 WITH SAFETY POST AS MFD. O' KEEFFS INC.
- N25 MOPSINK REFER TO PLUMBING DRAWINGS
- N26 FIRE EXTINGUISHER CABINET
- N28 OWNER FURNISHED REFRIGERATOR
- N29 OWNER FURNISHED DRYERS
- N30 OWNER FURNISHED WASHER
- N39 OWNER FURNISHED WIRE SHELFING UNIT

**TOILET ACCESSORY SCHEDULE**

ALL MODEL NUMBERS BASED ON SELECTED WASHROOM EQUIPMENT WITHIN SPECIFICATIONS UNLESS OTHERWISE NOTED

MARK	DESCRIPTION
T1	GRAB BAR
T2	MIRROR
T3	TOILET TISSUE DISPENSER
T4	SOAP DISPENSER
T5	PAPER TOWEL DISPENSER

**EQUIPMENT SCHEDULE**

A	ADVANCE TABCO	FC-3-1824-18RL	SINK, 3 COMPARTMENT, OVERALL 30" F/B x 90" L/R, 18" DRAINBOARDS LEFT & RIGHT, S/S LEGS
A1	KROWNE METAL	14-814 L	FAUCET, 8" CENTERS, 14" SWING NOZZLE, REMOVABLE CARTRIDGE VALVE ASSEMBLY
B	ADVANCE TABCO	DTC-S70-48L	DISHTABLE, CLEAN S/S LEGS, 47" LONG, 16/304 STAINLESS CONSTRUCTION
C	SALVAJOR	100-SA-3-MRSS	DISPOSER WITH MANUAL REVERSING MRSS CONTROL, 208V/60HZ/1-PH, 10.2 AMPS
C1	SALVAJOR	LSA8	DISPOSER SUPPORT LEG
D	ADVANCE TABCO	DTS-S70-48R	DISHTABLE, SOILED WITH PRE-RINSE SINK, S/S LEGS, 47" LONG
D1	ADVANCE TABCO	DTA-100	PRE-RINSE BASKET
D2	ADVANCE TABCO	K-452	CONTROL BRACKET 8"x12", FOR SALVAJOR 100SA-3-MRSS CONTROLS
D3	KROWNE METAL	17-108WL	PRE-RINSE ASSEMBLY WALL MOUNTED 8" CENTERS W/ WALL BRACKET
E	ADVANCE TABCO	DT-6R-23	SORTING SHELF, TUBULAR DESIGN 24" DEEP x 62" LONG, MOUNT 5'-0" AFF
F	TURBO AIR	TSR-49SD	REFRIGERATOR, REACH-IN, 2 DOOR W/STAINLESS INTERIOR, 115V/60/1, 9.2 AMPS, 4" CASTERS
G	TURBO AIR	TSF-49SD	FREEZER, REACH-IN, 2 DOOR W/STAINLESS INTERIOR, 115V/60/1, 10.3 AMPS, 4" CASTERS
J	ADVANCE TABCO	7-PS-83	HAND SINK WITH TOWEL & SOAP DISPENSER 9"x9"x5" DEEP, DECK MOUNTED FAUCET
K	JACKSON WWS	CONSERVOR XL-E-C	CORNER MACHINE, DOOR TYPE, SS, 3/4" HP, 115V/60/1, 11.4 AMP
L	ADVANCE TABCO	SKG-306	WORK TABLE, 30" WIDE TOP, 72" LONG, 5" BACKSPLASH, ADJUSTABLE S/S UNDERSHELF, S/S BULLET FEET
L.1	ADVANCE TABCO	SS-2015	2 DELUXE DRAWERS, MODIFIED TO 15"x20"x5" S/S W/ DRAWER SLIDES
L.2	ADVANCE TABCO	TA-31	2 SIDE SPLASHES, 5" HIGH
N	ADVANCE TABCO	SKG-308	WORK TABLE WITH RIGHT SINK (16"x20"x12" DP BOWL), 30" WIDE x 96" LONG, DECK FAUCET
N.1	ADVANCE TABCO	SS-2015	DELUXE DRAWER, MODIFIED TO 15"x20"x5" S/S W/ DRAWER SLIDES
O	ADVANCE TABCO	SAG-366	WORK TABLE, 36" X 72" S/S TOP, WITHOUT SPLASH, FRAME & ADJUSTABLE UNDERSHELF, BRAKES ON ALL CASTERS
O.1	ADVANCE TABCO	TA-25B	SONIC STEAMER MICROWAVE OVEN, 2100 WATTS, 208V/60/1-PH, 20 AMP
P	PANASONIC	NE-2180	TRASH RECEPTACLE
Q	N&N	24	CAN RACK, PROVIDED BY OWNER
R	MVP GROUP	AX-824H	AXIS CONVECTION OVEN, FULL SHEET PAN CAPACITY, 3900W, 208V/60/1-PH, 16.5 AMP
T	ADVANCE TABCO	WS-12-96	SHELF, WALL MOUNTED, 12" WIDE, 96" LONG S/S, MOUNT 5'-0" AFF.
U	CAPTIVE-AIRE	4830VH-B-G	4'-0" LONG CONDENSATE DISHWASHER HOOD SYSTEM WITH PERIMETER GUTTER
U.2	CAPTIVE-AIRE	STAINLESS PANELS	430 SS - 72"x48" BACKSPLASH, INCLUDES END CAPS AND DIVIDER BARS



ARCHITECTS INTERIORS, INC.  
architectural interior design-client services  
AIA/CES 12/27

4301 Anchor Plaza Parkway, Ste 100  
Tampa, FL 33634-7525  
813.884.2000

280 West Central Avenue  
Winter Haven, FL 33880-2957  
863.577.2054

BRYAN L. KARSKY

NO. DATE BY DESCRIPTION

CONSTRUCTION DOCUMENTS  
**RESTROOM PLANS, ELEVATIONS, SECTIONS**  
DAYCARE FACILITY FOR  
**CREATIVE WORLD SCHOOL**  
NAPLES, FL  
VANDERBILT BEACH RD.

ISSUED FOR:  
PROJECT NUMBER:  
15098  
DATE:  
9.21.2018  
DRAWING NUMBER:  
**A600**

**Question** - Does Section 604.8.1.7 and Advisory Section 604.8.1.6 of the FACBC mandate the requirement to provide a lavatory within a single user toilet room as it specifically relates to the Creative World School Project in which there are single user toilet rooms serving the following rooms/spaces that are designed only with a toilet and the lavatory is located outside of the toilet room -

- ▶ Toddlers Daycare
- ▶ Two Year Old Daycare
- ▶ Three Year Old Daycare
- ▶ Four Year Old Daycare

**Response** - Our answer is no, the FACBC does not require the lavatory to be within the single user toilet room.

The Collier County Building Department stated the following -

**Comments From The Plans Reviewer** - Gentleman, Advisory 604.8.1.6 Lavatory and 604.8.1.7 Water Closet. Florida law, section 553.504(5), F.S., stipulates that "...required bathing rooms and toilet rooms in new construction shall be designed and constructed..." with an accessible lavatory in the wheelchair accessible compartment and the water closet located in a corner diagonal to the door. The ADA Standards for Accessible Design and therefore this code require wheelchair accessible compartments in new construction and in alterations of existing buildings to have self closing doors. While the Florida lavatory requirement and water closet placement apply only to new construction, they are desirable for all wheelchair accessible compartments and should be considered where feasible.

Respectfully,

Tim Rygiel, CFM  
Plumbing Plans Examiner and Inspector

**Response Comments** - Here is what the sections referenced actually state - **604.8.1.6 Lavatory.** In new construction, **the wheelchair accessible toilet compartment** shall contain an accessible lavatory within it, which must be at least 19 inches wide by 17 inches deep, nominal size, and wall-mounted. The lavatory shall be mounted so as not to overlap the clear floors pace areas required by section 604 for the wheelchair accessible toilet compartment and shall comply with section 606. Such lavatories shall be counted as part of the required fixture count for the building. See also section 213.3.4.

**Advisory 604.8.1.6 Lavatory and 604.8.1.7 Water Closet.** Florida law, section 553.504(5), F.S., stipulates that "...required bathing rooms and toilet rooms in new construction shall be designed and constructed..." with an accessible lavatory in the wheelchair accessible compartment and the water closet located in a corner diagonal to the door. The ADA Standards for Accessible Design and therefore this code require wheelchair accessible compartments in new construction and in alterations of existing buildings to have self closing doors. While the Florida lavatory requirement and water closet placement apply only to new construction, they are desirable for all wheelchair accessible compartments and should be considered where feasible.

**Section 604.8.1.7** Water Closet states that in new construction, the accessible water closet within the wheelchair accessible compartment shall be located in the corner, diagonal to the door.

**What The Florida State Statute States** - 553.504 (5) Notwithstanding ss. 213 and 604 of the standards, required bathing rooms and toilet rooms in new construction shall be designed and constructed in accordance with the following:

- (a) **The wheelchair accessible toilet compartment must contain an accessible lavatory within it**, which must be at least 19 inches wide by 17 inches deep, nominal size, and wall-mounted. The lavatory shall be mounted so as not to overlap the clear floor space areas required by s. 604 of the standards for the wheelchair accessible toilet compartment and comply with s. 606 of the standards. Such lavatories shall be counted as part of the required fixture count for the building.
- (b) The accessible water closet within the wheelchair accessible toilet compartment must be located in the corner, diagonal to the door.

**LMS Comments** - It appears that Collier County is reading the section regarding the requirement for an accessible lavatory within the wheelchair accessible toilet compartment [toilet stall] to also mean that a lavatory is required within a toilet room. Florida State Statute 553.504 (5) clearly states that a lavatory is required, within the wheelchair toilet compartment [toilet stall] under new construction. The toilet rooms in question are single user toilet rooms serving the daycare rooms. It has been standard design practice that for this age group, 2, 3, and 4 year olds, within a daycare facility, that the toilet room only has a toilet in it and that the lavatory be located outside the toilet room, within the daycare room and the reasoning for same has been clearly stated by Dr. Marianne Whitehouse, CEO of Creative World School Franchising -

- ▶ Our classrooms sinks are strategically located within the classroom, right outside the toilet room. This specific location allows for teachers to assist children with their hand-washing and ensure that the proper steps are taken, as toddlers and young preschoolers need assistance with pumping soap, washing thoroughly, and turning the water on and off. Our teachers are able to offer this assistance while still maintaining the required supervision of the rest of the students. If sinks were placed inside the toilet rooms, they would be a tempting source of fun, or be bypassed completely when children are in a hurry to return to an activity. Additionally, if the sinks were located within the toilet room, it would lengthen the amount of time the room is occupied by an individual child. With our room layout, we are able to have one child using the toilet room while two others complete the hand-washing process. We are very mindful that when children are toilet training and learning these important skills, every moment counts. Most importantly, the safety and supervision of our children in a busy classroom is essential. We know that if teachers had to keep stepping into the toilet room, it would create a potential supervision issue for the rest of the children. Our toilet room design is strategic to give every child access, while maintaining the supervision that young children need as they are developing early self-help skills.

It is important to note that the Florida Accessibility Code for Building Construction is based upon Part III of the Americans with Disabilities Act, Public Law 101-336, 28 CFR Part 36 - Nondiscrimination on the Basis of Disability by Public Accommodations and in Commercial Facilities and the 2010 ADA Standards for Accessible Design. Since Florida's accessibility code is based upon these documents, we can rely on their interpretations and/or requirements for Florida's accessibility compliance. Within Part III of the Americans with Disabilities Act, Public Law 101-336, 28 CFR Part 36 - Nondiscrimination on the Basis of Disability by Public Accommodations and in Commercial Facilities it states that unless specifically stated otherwise, **advisory notes, appendix notes, and figures** contained in the 1991 Standards and 2010 Standards explain or illustrate the requirements of the rule; they do not establish enforceable requirements.<sup>1</sup>

Therefore the reliance on the advisory section 604.8.1.6 is not a section of the Florida Accessibility Code that is enforceable. It is strictly an advisory item and as highlighted in grey is Florida specific text that was added to the base document; which is the 2010 ADA Standards as noted on the cover page of the FACBC.

Section 604.8.1.6 Lavatory clearly states that in new construction, **the wheelchair accessible toilet compartment shall contain an accessible lavatory within it.** There is no requirement that this language requires that a lavatory is required within a single user toilet room; it states that within the accessible toilet stall, in new construction, you are required to have a lavatory within that toilet stall.

We have also taken the liberty to include six Certificate of Occupancy's that have been provide to this type of daycare project in which those jurisdictions have accepted this design solution of the single user daycare room with just a toilet in it and the lavatory directly outside of that toilet room.

So, the question is does the FACBC - 2012 sections 604.8.1.7 and Advisory Section 604.8.1.6 of the FACBC mandate the requirement to provide a lavatory within a single user toilet room as it specifically relates to the Creative World School Project in which there are single user toilet rooms serving the rooms/spaces that are designed only with a toilet and the lavatory is located outside of the toilet room.

Pursuant to the applicable sections referenced above and the language of the Florida State Statute it is our opinion that the FACBC does not require a lavatory within a single user toilet room; but it does require a lavatory within an accessible toilet compartment in new construction and a single user toilet room and a toilet stall are not the same

Attached you will find copies of the floor plans of the project in question. We look forward to meeting with you to address and resolve this interpretation of the FACBC.

---

<sup>1</sup>§36.406(b)