

## **SUNRISE CINEMAS**

**Issue:** Vertical accessibility to all rows of seats in an existing movie theater complex.

**Analysis:** The applicant is requesting a waiver from providing vertical accessibility to all rows of seats in an existing 8-screen movie theater complex. The theaters range from providing 72 to 221 seats and the appropriate number of wheelchair seating locations with companion seats are provided. The project will cost \$773,000 and the applicant provided documentation that it would cost an additional \$326,859 to install lifts to make each row accessible.

### **Project Progress:**

The project is under design.

### **Items to be waived:**

Vertical accessibility to all rows of seats in a stadium type movie theater complex, as required by Section 553.509, Florida Statutes.

553.509 **Vertical accessibility.** Nothing in Sections 553.501-553.513 or the guidelines shall be construed to relieve the owner of any building, structure or facility governed by those sections from the duty to provide vertical accessibility to all levels above and below the occupiable grade level regardless of whether the guidelines require an elevator to be installed in such building, structure or facility, except for:

- (1) Elevator pits, elevator penthouses, mechanical rooms, piping or equipment catwalks and automobile lubrication and maintenance pits and platforms;
- (2) Unoccupiable spaces, such as rooms, enclosed spaces and storage spaces that are not designed for human occupancy, for public accommodations or for work areas; and
- (3) Occupiable spaces and rooms that are not open to the public and that house no more than five persons, including, but not limited to equipment control rooms and projection booths.

**Waiver Criteria:** There is no specific guidance for a waiver of this requirement in the code. The Commission's current rule, authorized in Section 553.512, Florida Statutes, provides criteria for granting waivers and allows consideration of unnecessary or extreme hardship to the applicant if the specific requirements were imposed.

This application is available in alternate formats upon request.

**REQUEST FOR WAIVER FROM ACCESSIBILITY REQUIREMENTS  
OF CHAPTER 553, PART V, FLORIDA STATUTES**

Your application will be reviewed by the Accessibility Advisory Council and its recommendations will be presented to the Florida Building Commission. You will have the opportunity to answer questions and/or make a short presentation, not to exceed 15 minutes, at each meeting. The Commission will consider all information presented and the Council's recommendation before voting on the waiver request.

**1. Name and address of project for which the waiver is requested.**

Name: Sunrise Cinemas - Deerfield Mall  
Address: 3984 w Hillsboro Blvd  
Deerfield Beach, FL 33442

**2. Name of Applicant. If other than the owner, please indicate relationship of applicant to owner and written authorization by owner in space provided:**

Applicant's Name: TK Architects c/o Jennifer Meyer

Applicant's Address: 106 w. 11th St. Kansas City, MO 64105

Applicant's Telephone: 816-842-7552 FAX: 816-842-1302

Applicant's E-mail Address: jmeyer@tkarch.com

Relationship to Owner: Architect of Record

Owner's Name: Sunrise Cinemas

Owner's Address: 4321 NW 88th Ave. Sunrise, FL 33351

Owner's Telephone: 954-749-4155 FAX 954-749-4156

Owner's E-mail Address: mdreier@sunrisecinemas.com

Signature of Owner: [Signature]

Contact Person: Mitch Dreier

Contact Person's Telephone: 954-749-4155 E-mail Address: mdreier@sunrisecinemas.com

This application is available in alternate formats upon request.  
Form No. 2001-01

3. Please check one of the following:

New construction.

Addition to a building or facility.

Alteration to an existing building or facility.

Historical preservation (addition).

Historical preservation (alteration).

4. **Type of facility.** Please describe the building (square footage, number of floors). Define the use of the building (i.e., restaurant, office, retail, recreation, hotel/motel, etc.)

Existing single story (with mezzanine) 8 screen movie theater. Approximately 31,870 sf with 968 seats.

5. **Project Construction Cost (Provide cost for new construction, the addition or the alteration):**

\$773,300

6. **Project Status:** Please check the phase of construction that best describes your project at the time of this application. Describe status.

Under Design  Under Construction\*

In Plan Review  Completed\*

\* Briefly explain why the request has now been referred to the Commission.

---

---

---

7. **Requirements requested to be waived.** Please reference the applicable section of Florida law. Only Florida-specific accessibility requirements may be waived.

**Issue**

1: Florida Building Code, Section 553.509 Vertical Accessibility

**Issue**

2: \_\_\_\_\_  
\_\_\_\_\_

**Issue**

3: \_\_\_\_\_  
\_\_\_\_\_

8. **Reason(s) for Waiver Request:** The Florida Building Commission may grant waivers of Florida-specific accessibility requirements upon a determination of unnecessary, unreasonable or extreme hardship. Please describe how this project meets the following hardship criteria. Explain all that would apply for consideration of granting the waiver.

The hardship is caused by a condition or set of conditions affecting the owner which does not affect owners in general.

\_\_\_\_\_  
\_\_\_\_\_

Substantial financial costs will be incurred by the owner if the waiver is denied.

Please refer to the attached letter

The owner has made a **diligent investigation** into the costs of compliance with the code, but cannot find an efficient mode of compliance. Provide detailed cost estimates and, where appropriate, photographs. Cost estimates must include bids and quotes.

---

---

9. Provide documented cost estimates for each portion of the waiver request and identify any additional supporting data which may affect the cost estimates. For example, for vertical accessibility, the lowest documented cost of an elevator, ramp, lift or other method of providing vertical accessibility should be provided, documented by quotations or bids from at least two vendors or contractors.

a. Please refer to attached letter in conjunction with attached pricing data

b. \_\_\_\_\_

c. \_\_\_\_\_

10. **Licensed Design Professional:** Where a licensed design professional has designed the project, his or her comments **MUST** be included and certified by signature and affixing of his or her professional seal. The comments must include the reason(s) why the waiver is necessary.

---

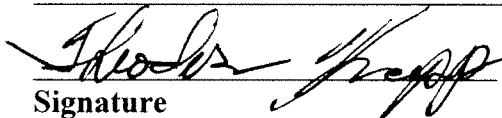
 THEODORE KHADD  
Signature Printed Name

Phone number 816-842-7552

(SEAL)

**CERTIFICATION OF APPLICANT:**

I hereby swear or affirm that the applicable documents in support of this Request for Waiver are attached for review by the Florida Building Commission and that all statements made in this application are to the best of my knowledge true and correct.

Dated this 16 day of June, 20 09

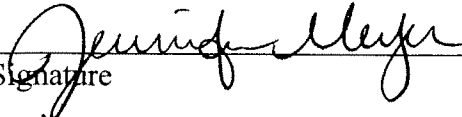
  
Signature

Jennifer Meyer  
Printed Name

By signing this application, the applicant represents that the information in it is true, accurate and complete. If the applicant misrepresents or omits any material information, the Commission may revoke any order and will notify the building official of the permitting jurisdiction. Providing false information to the Commission is punishable as a misdemeanor under Section 775.083, Florida Statutes.



106 W. 11<sup>TH</sup> STREET SUITE 1900  
KANSAS CITY, MO 64105  
P. 816.842.7552 E. 816.842.1302

AA 000 2411

June 17, 2009

Request for Waiver Form  
Accessibility Requirements  
of Chapter 553, Part V,  
Florida Statutes

Re: Sunrise Cinemas  
Deerfield Mall  
TKA – 08065/113

Item 8:

Reason for Waiver Request

Substantial financial costs will be incurred by the owner if the waiver is denied.

The Sunrise Cinema at Deerfield is an 8-screen existing sloped floor theater being converted into an 8-screen stadium seating movie theatre. Stadium seating allows for unobstructed patron viewing of movies and is the issue for consideration of the Accessibility Waiver.

Each of the 8 auditoriums is comprised of tiered seating platforms of varying elevations ranging from 18" to 6" difference between adjacent platforms. Wheelchair accessible seating locations were improved by relocating them from the rear of the auditoriums to the center of the auditoriums. The new locations are designed in accessible viewing locations in each auditorium with companion seating and to maximize the view angle to the top of the screen to be less than 30°. Additional ambulatory accessible seating is accommodated by providing lift up arms on all aisle seats. To design this theatre to provide wheelchair accessibility to every row of stadium seating will cause extreme hardship to the Owner as follows:

I To design the physical space required for each lift, and access on each side of the lift, additional space would need to be designed into each row. As this is an existing building, the additional space would result in the loss of approximately 60% of the designed seating capacity from 968 to 391 seats. This would result in the loss of revenue as follows:

\$1400.00 in revenue per seat x loss of (577) seats = \$807,800 per year

II (39) chair lifts would be required to access every row of seating:

Vertical Platform Lift Pricing

|                            |                      |                |
|----------------------------|----------------------|----------------|
| Mac's Lift Gate, Inc.      | #PL50                | \$5,120        |
| <b>Planet Mobility</b>     | <b>#Trust T Lift</b> | <b>\$7,760</b> |
| Jazzy-Electric-Wheelchairs | #Mobilift CX         | \$10,499       |

We have chosen the mid-range priced lift.

Per RS Means Construction Cost Data 2006, add 8% of the material cost for installation.

Therefore, (1) Lift, furnished and installed: \$7,760 + \$621 = \$8,381

(39) Lifts furnished and installed: \$8,381 x 39 = \$326,859 additional cost.

III

In Summary:

Additional building costs for vertical accessibility:

Loss of revenue for Additional SF per lift \$ 807,800 per year

Platform Lifts (39) \$ 326,859  
Material & Labor

Total Financial Hardship: \$ 1,134,659

Compared to the original building cost estimate:

\$ 773,308

Prepared by,

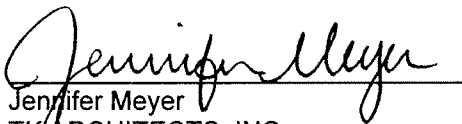

Jennifer Meyer  
TK ARCHITECTS, INC.  
Applicant

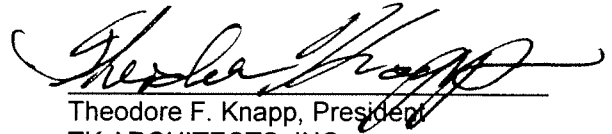

Theodore F. Knapp, President  
TK ARCHITECTS, INC.  
Design Professional

JM/jl

### Wheelchair Lifts

| <u>Model</u> | <u>Price</u> | <u>Website</u>   | <u>Phone</u> |
|--------------|--------------|--|--------------|
| Mobilift CX  | \$10,499     | <a href="http://www.jazzy-electric-wheerchairs.com">www.jazzy-electric-wheerchairs.com</a> | 800-647-0803 |
| PI50         | \$5,120      | <a href="http://www.macslift.com">www.macslift.com</a>                                     | 800-795-6227 |
| Trust T Lift | \$7,760      | <a href="http://www.planetmobility.com">www.planetmobility.com</a>                         | 866-465-4387 |



- [Vertical Platform Lifts](#)
- >
- Mobilift CX Vertical Wheelchair Lift

### Description

The Mobilift CX is a very special wheelchair lift. It is manually operated and is portable, so it can be quickly and easily set up. It supports up to 600 pounds and has a standard 60 inch lifting height.

This portable wheelchair lift comes fully assembled and only requires 11 pounds of force to lift 300 pounds. This porch lift can be operated by almost anyone and it typically only takes 20 seconds to fully raise this wheelchair lift.

### Specs

- Lifting Capacity: 600 lb
- Standard Lift Height: 60"
- Maximum Lift Height: 60"
- Portable: Yes
- Arrives Assembled: Yes
- Drive System: Manual Crank
- Optional Drive Systems: None Available
- Battery Powered Option: No
- Constant Pressure Platform Control: No
- Emergency Stop Platform Control: N/A
- Alarm Button: N/A
- Keyed Platform Control: N/A
- Call-Send Controls: N/A
- Optional Call-Send Controls: N/A
- Platform Type: Solid Aluminum
- Platform Size: 34" x 56"
- Optional Platform Sizes: None Available
- Platform Configuration: Adjacent Access
- Optional Platform Configurations: None Available
- Upper Landing Gate: None Available
- Upper Access Ramp: 20" Bridge, Optional 10", 30", 40", 50", 60"
- Lower Access Ramp: 40" Manual Folding Ramp
- Grab Rail: Standard
- Guard Panel: None Available
- Maximum Stops: 2

### Select Options

#### Price

\$10,499.00

MSRP \$14,990.00

[Add to Cart](#)



[Click to enlarge](#)

- [Brochure](#)
- [Specifications](#)
- [Case Study - Outdoor Stage](#)
- [Case Study - School Stage](#)
- [Case Study - Church](#)
- [Case Study - Public Building](#)
- [Case Study - Parks System](#)

© Copyright 2008

Phone: 1 (800) 790-5523 · Fax: 1 (800) 791-6524

3901 Commerce Park Drive NC 27610  
[Return Policy](#) · [Privacy Policy](#)

- Visa
- Master Card
- American Express
  - Discover
  - Check

Jun 15, 2009

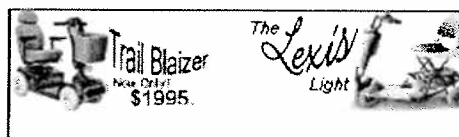

Power Wheelchairs



Showroom

### Commercial Wheelchair Lift

## Commercial

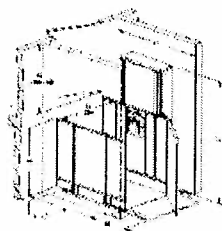

Planet mobility wheelchair lifts allow people with mobility issues to remain active, improving the quality of life. It's there personal freedom, and that is important to us ☐ That is our job.

Safety, comfort and convenience were Planet Mobility's #1 design considerations.

#### Features

- **Innovative Soft Touch Control Pads** for ease of operation.
- **Direct drive Worm-Gear / Screw-Nut Drive** for maintenance free operation, incorporating zero load start for cold weather climates (drive system allows motor to get up to full speed before lifting car).
- **Expanded Metal Platform** allows full under platform visibility.
- **Keyed Emergency Stop** to control use of lift.

Smooth and quiet performance makes this light weight, dependable and versatile unit perfect for any residential or commercial application.

Our High Tower Lift's will go as high as 12' Feet and can be used with many applications.

"Straight Trough": Straight through application means that the lift would be entered by one side and after raising and reaching the destination landing would be exited on the opposite side.

"Adjacent Access": Adjacent access application means that the lift would be entered by one side and after raising and reaching the destination landing would be exited to the right or left.

"Same Side": Same side application means that the lift would be entered by one side and after raising and reaching the destination landing would be exited at the same location it was entered.

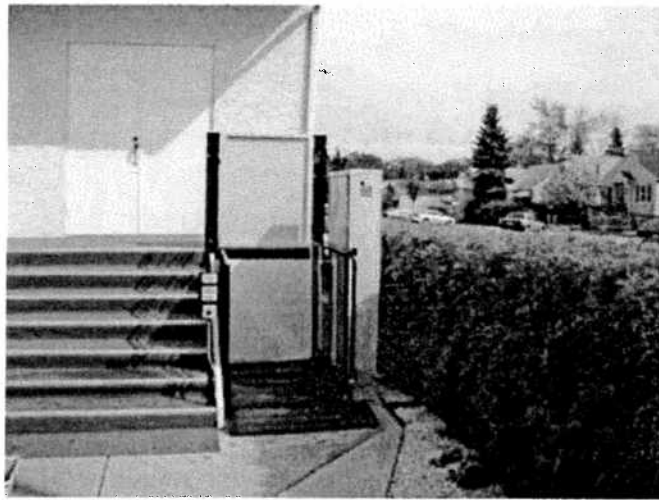

**Technical Specifications**

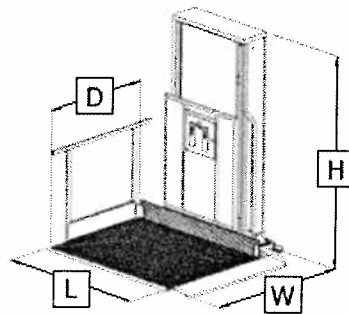

**Adjacent Access**

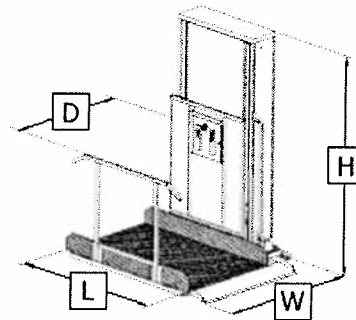

**Straight Through Access**

**Deck Dimensions (L, D, W)**

| Access                  | L<br>Deck Length | D<br>Deck Width | W<br>Total Width |
|-------------------------|------------------|-----------------|------------------|
| Straight Through Access | 54" (1372 mm)    | 34" (864 mm)    | 48" (1219 mm)    |
| Adjacent Access         | 54" (1372 mm)    | 40" (1016 mm)   | 54" (1372 mm)    |

**Tower Dimensions (H)**



| Total Travel               | H<br>Tower Height |
|----------------------------|-------------------|
| 28" (711 mm) Lift Height   | 48" (1219 mm)     |
| 52" (1321 mm) Lift Height  | 72" (1829 mm)     |
| 72" (1829 mm) Lift Height  | 92" (2337 mm)     |
| 96" (2438 mm) Lift Height  | 118" (2997 mm)    |
| 120" (3048 mm) Lift Height | 142" (3607 mm)    |
| 144" (3658 mm) Lift Height | 166" (4216 mm)    |

---

### Technical

- Constant pressure Soft Touch control pads
  - 550 pound (250-kg) lift capacity
  - Constant pressure Soft Touch control pads
  - 8 feet/minute lift speed
  - Direct worm gear/acme screw drive
  - Non-load-bearing backup safety nut on lift shaft
  - Low maintenance
  - Expanded metal platform with full under platform visibility and non skid surface
  - 8" positive action, reversible toe-plate for universal access
  - Emergency manual operation
  - Fuse box accessible from carriage
  - Quick and easy set-up and adjustment
  - Baked on Powder Coat finish
  - Baked on Powder Coat finish
  - Extreme Weather resistant design
  - U.L. and C.S.A. Certified
- 

### Options

- Under platform safety plate and solid platform
- Carriage gate
- Landing gates
- Portable model
- Solid Hand Rail
- 12V DC battery backup
- 18" extra wide toe plate
- Remote call stations
- Electric Interlocks

[Commercial Lift - High Tower Lift - Residential Lift - Photos](#)

[View Drawings And Pricing Here.....!](#)



Tell a friend:



# (866) GO-LIFTS

Toll Free: (866) 465-4387

Phone: (586) 247-8900

14986 Technology Drive Fax: (586) 247-3435 Shelby TWP. MI 48315



## Planet Mobility Main Menu! - Online Mall

|                              |                                |                                  |                               |                                |                               |
|------------------------------|--------------------------------|----------------------------------|-------------------------------|--------------------------------|-------------------------------|
| <a href="#">Bathroom</a>     | <a href="#">Beds</a>           | <a href="#">Bikes</a>            | <a href="#">Ceiling Lifts</a> | <a href="#">Commode Lifts</a>  | <a href="#">Cushions</a>      |
| <a href="#">Door Openers</a> | <a href="#">Elevators</a>      | <a href="#">Fitness</a>          | <a href="#">Hand Bikes</a>    | <a href="#">Lift Chairs</a>    | <a href="#">Patient Lifts</a> |
| <a href="#">Phones</a>       | <a href="#">Pool Lifts</a>     | <a href="#">Ramps</a>            | <a href="#">Seat Lifts</a>    | <a href="#">Scooters</a>       | <a href="#">Scooter Lifts</a> |
| <a href="#">Slings</a>       | <a href="#">Stairway Lifts</a> | <a href="#">Standing Frames</a>  | <a href="#">Tie Downs</a>     | <a href="#">Transfer Lifts</a> | <a href="#">Walker</a>        |
| <a href="#">Wireless</a>     | <a href="#">Wheelchairs</a>    | <a href="#">Wheelchair Lifts</a> | <a href="#">Specials</a>      | <a href="#">Search</a>         | <a href="#">Main Menu!</a>    |

14986 Technology Dr Shelby Twp. Mi. 48315 (866) 465-4387 Fax: (586) 532-8279 www.planetmobility.com

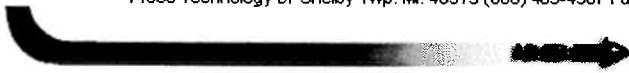

|  |                             |                                      |
|--|-----------------------------|--------------------------------------|
|  | <a href="#">Search Site</a> | <a href="#">Help Advanced Search</a> |
|--|-----------------------------|--------------------------------------|



Vertical Home Lift  
 Conversion Vans  
 New Vans  
 Used Vans  
 Wheelchair Lifts  
 Ambulance Lift  
 Stair Lifts  
 Scooter Lifts  
 Transfer Lifts  
 Used Equipment  
 Contact Us  
 Directions  
 Home

MAC'S Lift Gate Inc.  
 2715 Seaboard Lane  
 Long Beach, CA  
 Zip 90805  
 Email  
 1-800-795-6227



#### **FREEDOM**

With a Bruno Independent Living Aids **Curved Rail Stairlift** or **Straight Rail Stairlift** you can go up and down stairs effortlessly, anytime you want.

#### **COMFORT**

Unlike ordinary chain or cable driven stairlifts, our units use a rack and pinion system, so there's no slipping or lurching when the unit stops and starts. Your ride is smooth and controlled. Your installer can even set the speed of the unit to suit your personal comfort level.

#### **PERFORMANCE**

All Bruno Straight Rail Stair lifts are designed and manufactured to accommodate rider weights of up to 350 lbs., which positions Bruno stairlift systems as a leader in the industry.

#### **BATTERY-POWERED OPERATION**

Battery operation assures you of access between floors even if an electrical outage occurs. The unit charges automatically when it is parked both at the top or bottom of the stairway.

#### **INSTALLATION**

Because of the battery-powered operation there is no special wiring required for installation. The unit uses a 3-amp charger that will operate on a standard 110 volt wall outlet.

#### **CALL-SEND**

The Bruno Straight Rail Stair lift utilizes a wireless "call-send" control which allows you to call or send the unit to the other end of the stairs. This wireless system can either be mounted on a wall or can be used as a hand held remote.

**QUALITY**

Designed, manufactured and assembled under ISO 9001 standards.



**"50 Years of Serving the Disabled Community"**

**MAC'S Lift Gate Inc.**  
2715 Seaboard Lane  
Long Beach, CA 90805

**Phone** 1-562-634-5962  
1-800-795-6227  
**Fax** 1-562-634-4291

Contact Us

(c) 2006 MAC'S Lift Gate Inc. All Rights Reserved



**REVIEW AND RECOMMENDATION BY LOCAL BUILDING DEPARTMENT.**

Please state why the issue is being referred to the Florida Building Commission as well as a recommendation for disposition. The Building Official or his or her designee should review the application and indicate that to the best of his or her knowledge, all information stipulated herein is true and accurate. Further, if this project is complete, explain why it is being referred to the Commission. The Building Official or his or her designee should sign a copy of the plans accompanying this application as certification that such plans are the same as those submitted for building department review. Please reference the applicable section of the Accessibility Code.

- a. FL Building Code, Section 553.509 Vertical Accessibility
- b. \_\_\_\_\_
- c. \_\_\_\_\_

Has there been any permitted construction activity on this building during the past three years? If so, what was the cost of construction?

Yes  No Cost of Construction \_\_\_\_\_

**Comments/Recommendation** \_\_\_\_\_  
\_\_\_\_\_

Jurisdiction \_\_\_\_\_

Building Official or Designee \_\_\_\_\_  
Signature

\_\_\_\_\_  
Printed Name

\_\_\_\_\_  
Certification Number

\_\_\_\_\_  
Telephone/FAX

Address: \_\_\_\_\_  
\_\_\_\_\_

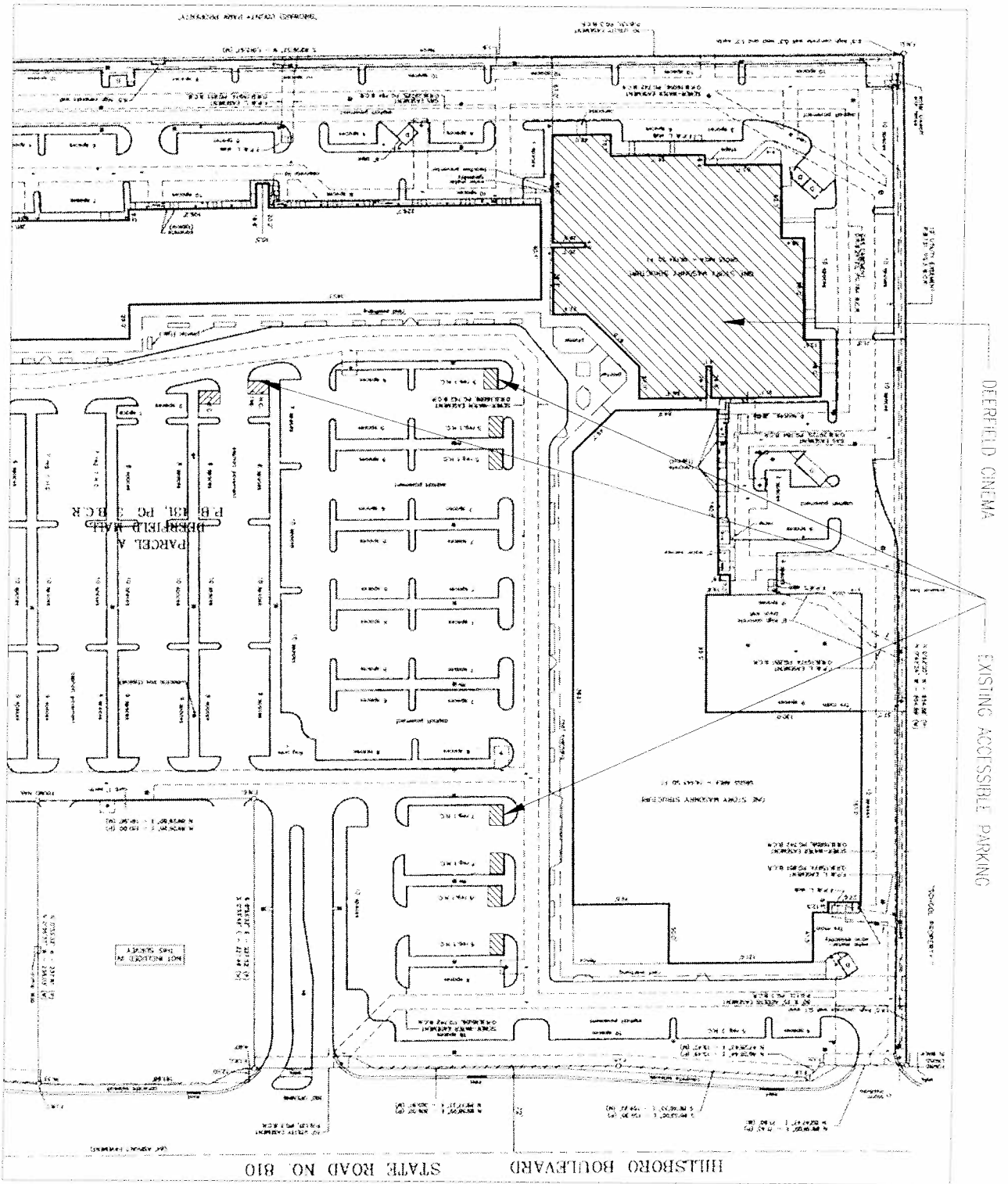

DEERFIELD CINEMA

EXISTING ACCESSIBLE PARKING

SITE PLAN



106 West 11th  
 Kansas City, MO  
 1-816-542-7552 Fax 1-816-542-1332

Suite 1902  
 64120, USA

**Sunrise  
 Cinemas®**

DEERFIELD  
 CINEMAS INTERIOR  
 RENOVATION  
 DEERFIELD BEACH, FL

DATE 06-15-09  
 PROJECT # 08065.00

SITE PLAN  
 SHEET No AC-1

REFERENCE 1/AC-100



**FLOOR PLAN**

**TK**  
ARCHITECTS INC.  
**TK**

106 West 11th, Suite 1900  
Kansas City, MO 64105 USA  
T 816 842 7082 Fax 816 842 1502

**Sunrise**  
**Cinemas**®

DEERFIELD  
CINEMAS INTERIOR  
RENOVATION  
DEERFIELD BEACH, FL

DATE 06-15-09  
PROJECT # 08065.00  
**FLOOR PLAN**  
SHEET No AC-2  
REFERENCE 1/AC-01

DATE 06-15-09  
 PROJECT # 08065.00  
 AUD. #1  
 SHEET NO. AC-3  
 21' X 11' 1/2" / AC-102

DEERFIELD  
 CINEMAS INTERIOR  
 RENOVIATION  
 DEERFIELD BEACH, FL

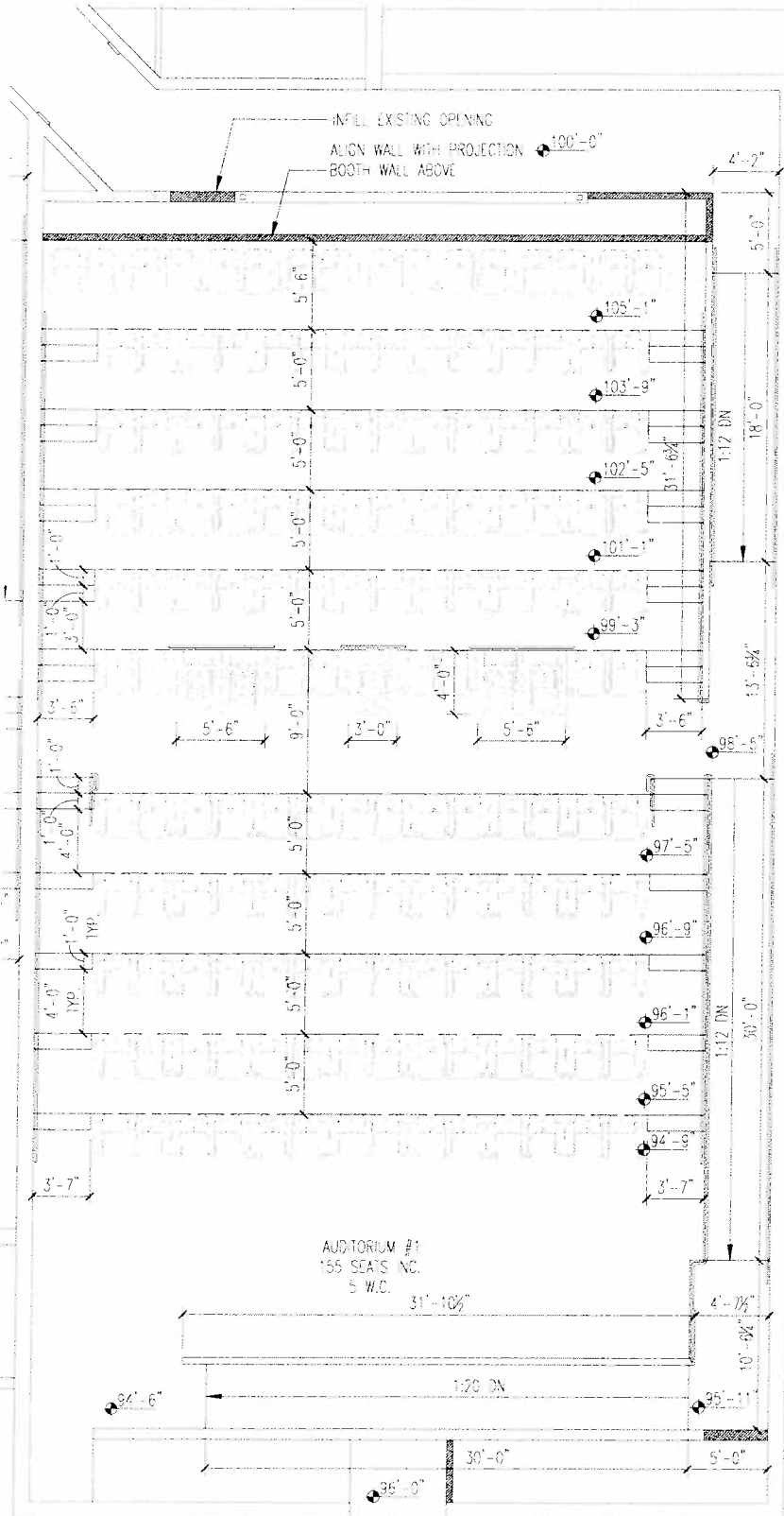
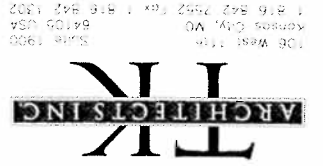
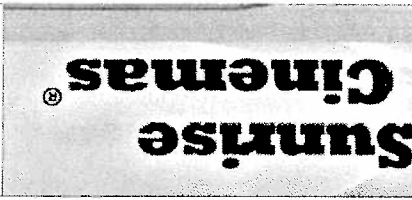

**ENLARGED AUD. #1 PLAN**

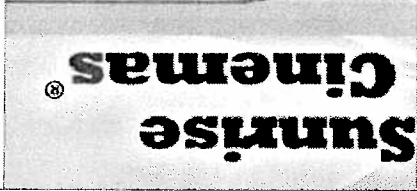

DEERFIELD CINEMAS INTERIOR RENOVATION  
 DEERFIELD BEACH, FL

DATE 06-15-09  
 PROJECT # 08069.00  
 ADD. #1  
 SHEET NO. AC-4  
 REVISIONS 2/AC-102

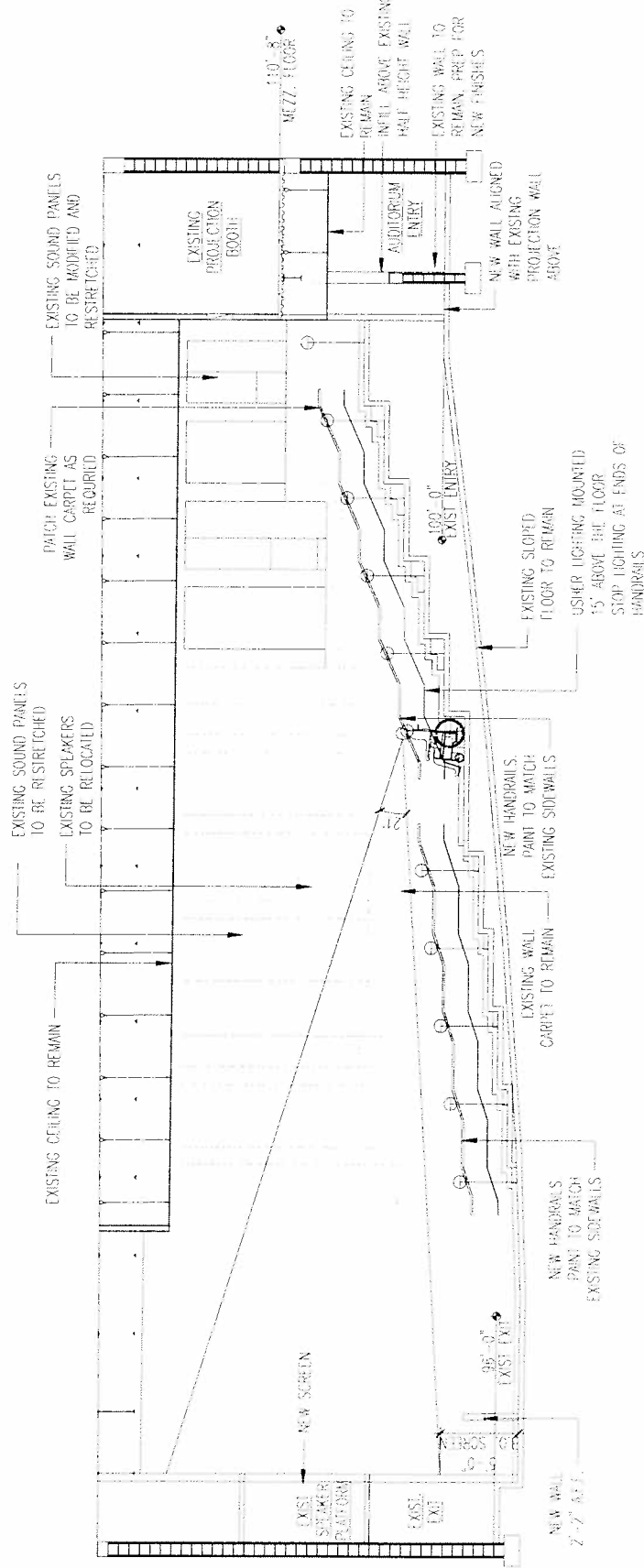

ALL SPEAKERS TO BE RELOADED FOR STADIUM SEALING

**SECTION @ AUD. #1**



DATE 06-15-09  
 PROJECT # 08065 00  
 AUD. #2 & 3  
 SHEET NO. AC-6  
 REFERENCE S/AC-102

DEERFIELD  
 CINEMAS INTERIOR  
 RENOVIATION  
 DEERFIELD BEACH, FL

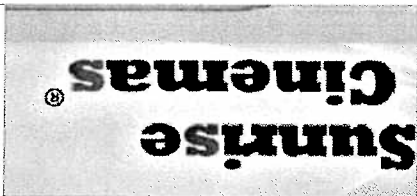

TK ARCHITECTS INC  
 100 West 11th  
 Kansas City, MO  
 64105 USA  
 816.842.2500 FAX 816.842.1500

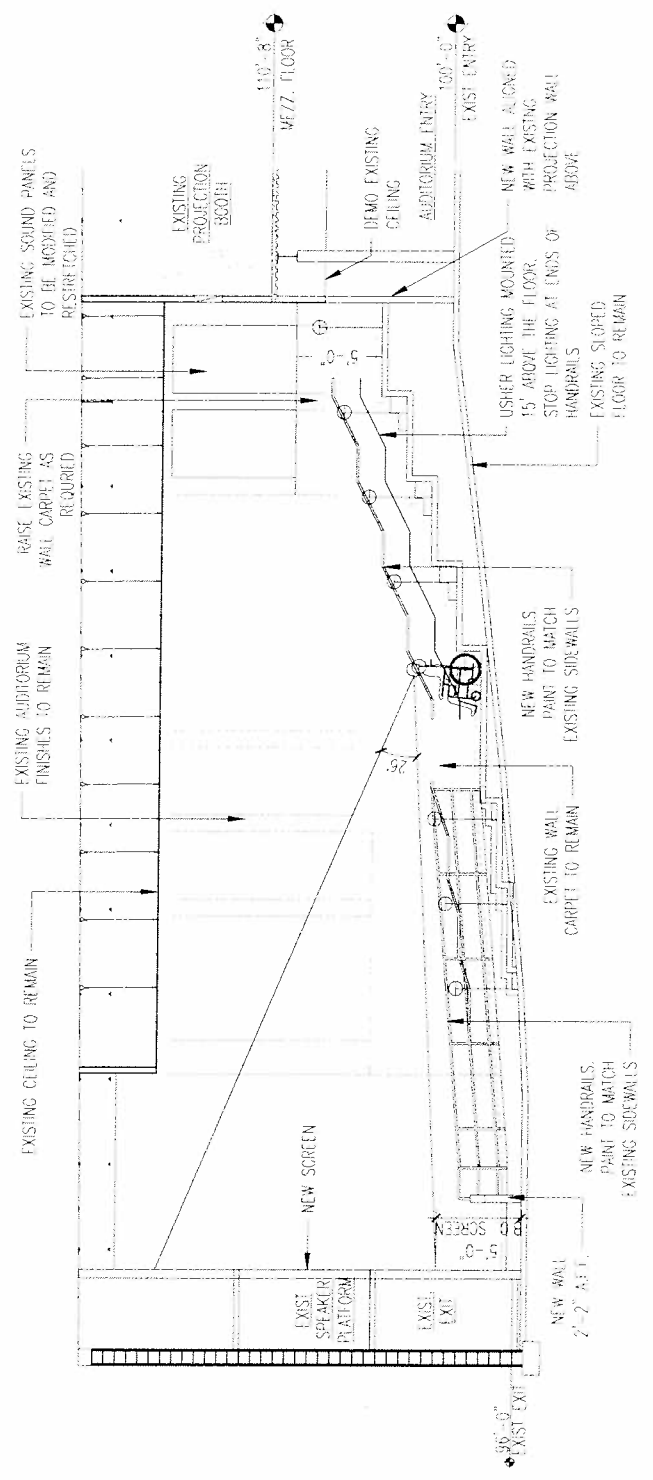

ALL SPEAKERS TO BE RELOCATED FOR STADIUM SEATING

**SECTION @ AUD. #2 (3 SIM.)**

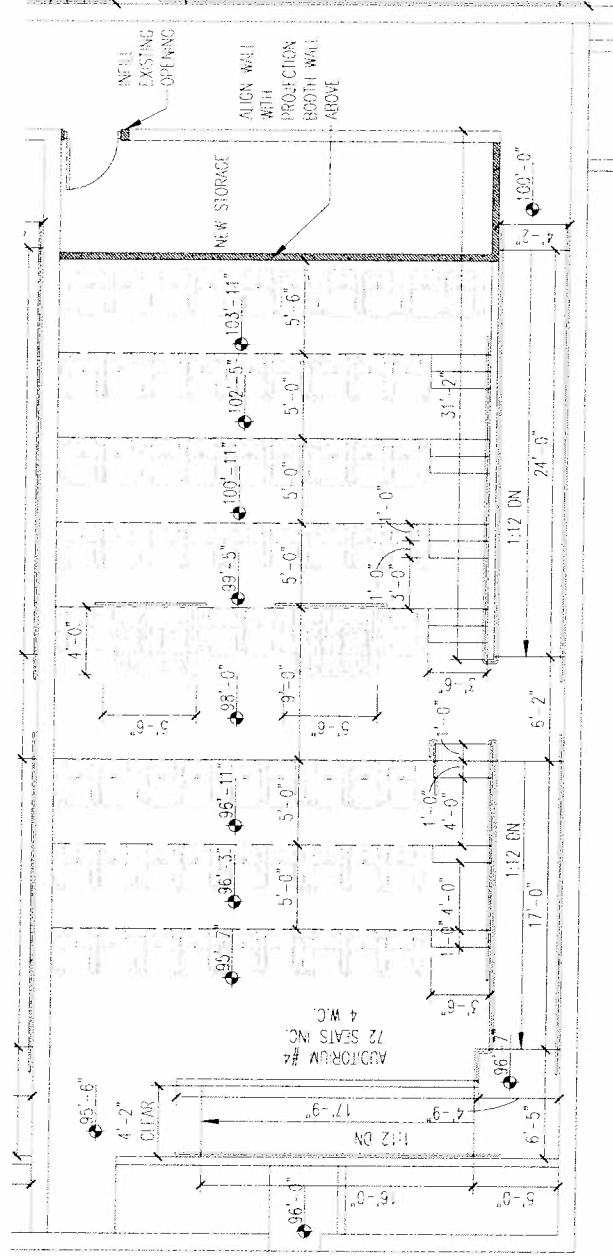

**ENLARGED AUD. #4 PLAN**



DATE 06-15-09  
 PROJECT # 08069.00  
 AUD. #4  
 SHEET NO. AC. 8  
 REFERENCE 2/AC-103

DEERFIELD  
 CINEMAS INTERIOR  
 RENOVIATION  
 DEERFIELD BEACH, FL

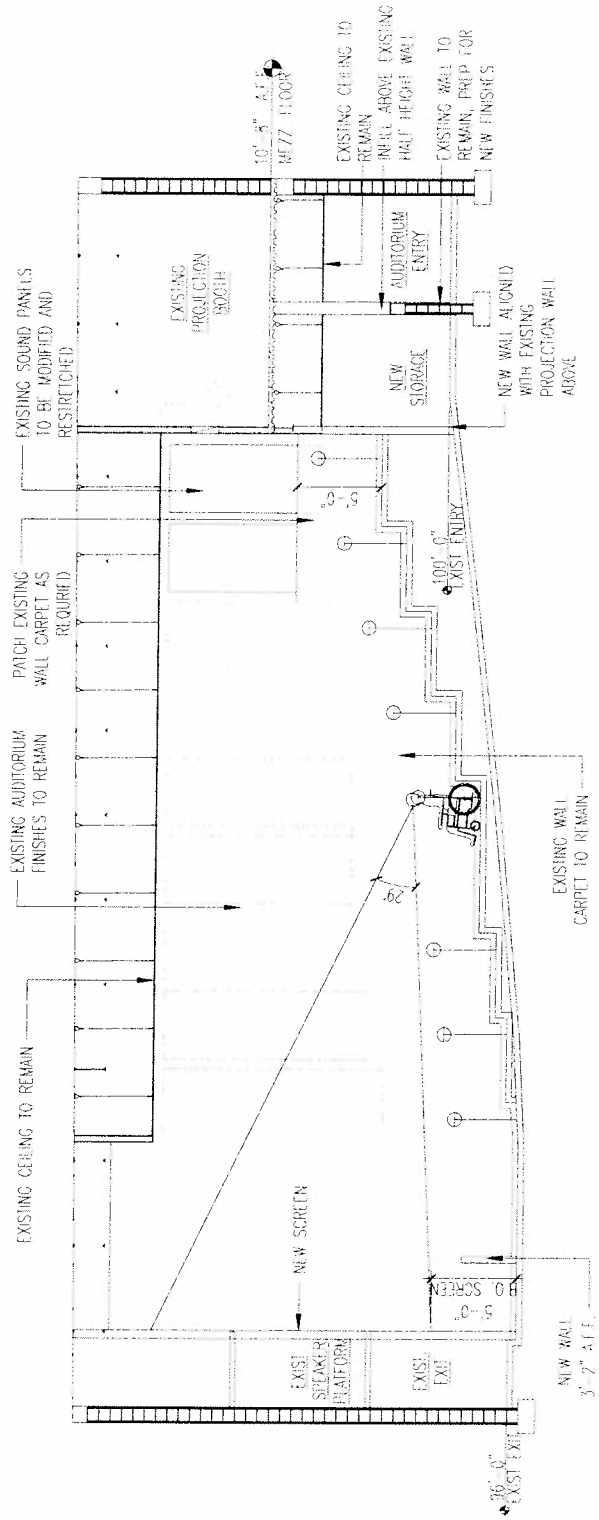
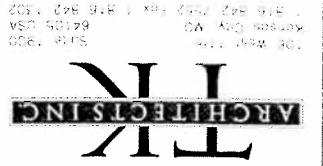
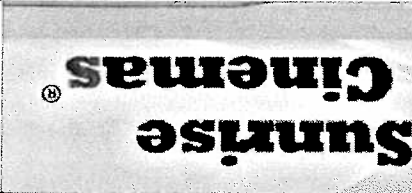

ALL SPEAKERS TO BE RELOCATED FOR STADIUM SEATING

**SECTION @ AUD. #4**

DATE: 05-15-09  
 PROJECT # 08065.00  
 AUD. #5  
 SHEET NO. AC-9  
 REFERENCE 4/AC-103

DEERFIELD  
 CINEMAS INTERIOR  
 RENOVATION  
 DEERFIELD BEACH, FL

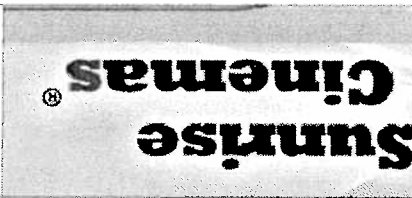

TK ARCHITECTS INC.  
 108 West 11th  
 Kansas City, MO 64105 USA  
 816.842.7552 FAX 816.842.1492

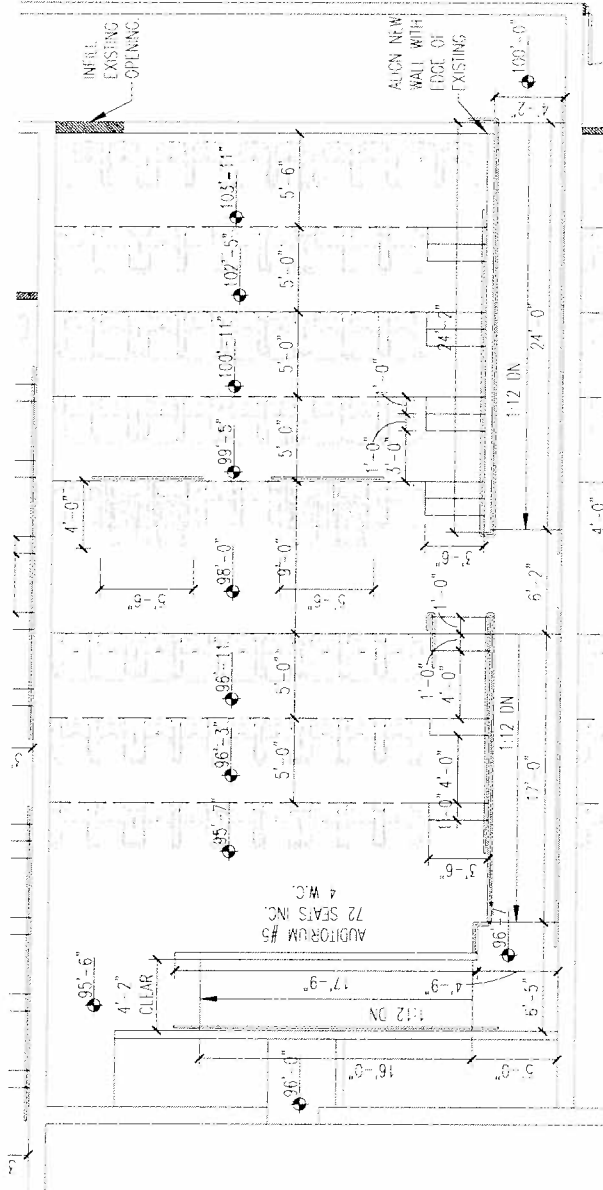

**ENLARGED AUD. #5 PLAN**

DATE 06-15-09  
 PROJECT # 08069.00  
 AUD. #5  
 SHEET NAAC-10  
 REFERENCE 5/AC-103

DEERFIELD  
 CINEMAS INTERIOR  
 RENOVATION  
 DEERFIELD BEACH, FL

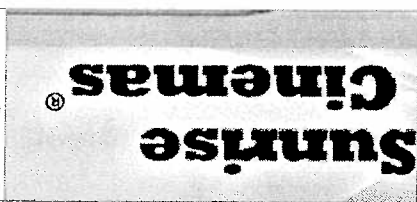

TK ARCHITECTS INC.  
 108 WEST 11TH  
 KANSAS CITY, MO 64105  
 816.849.7900 FAX 816.849.1532

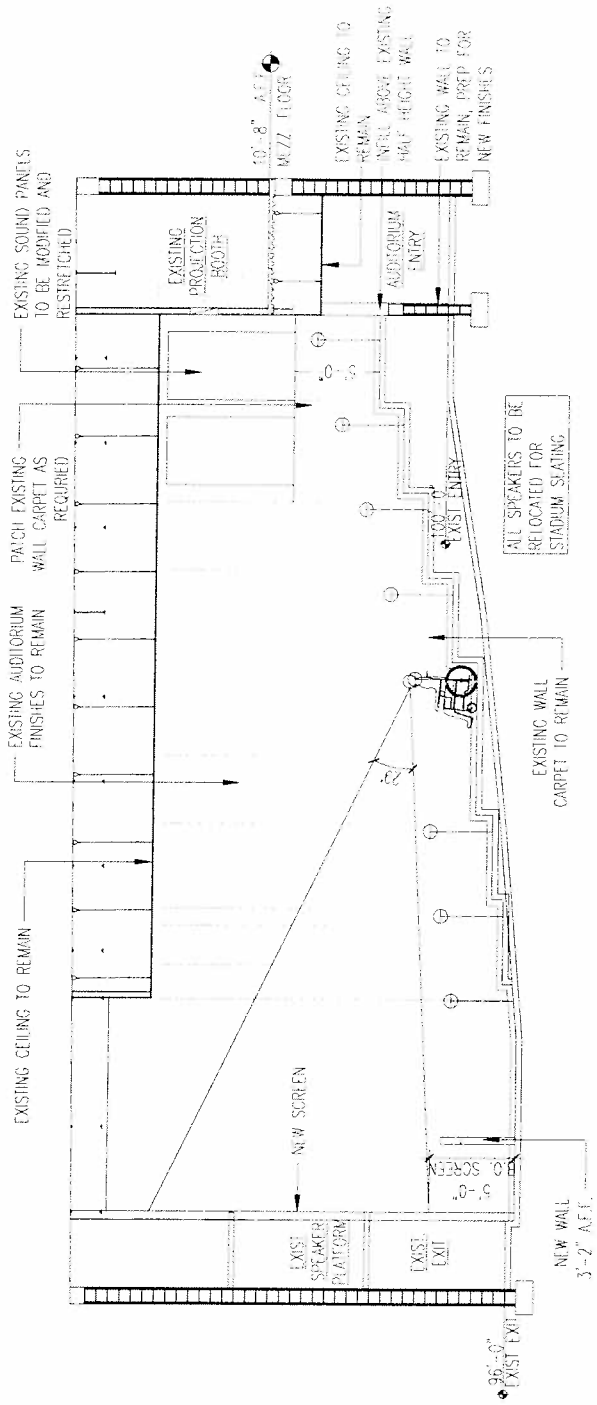

**SECTION @ AUD. #5**



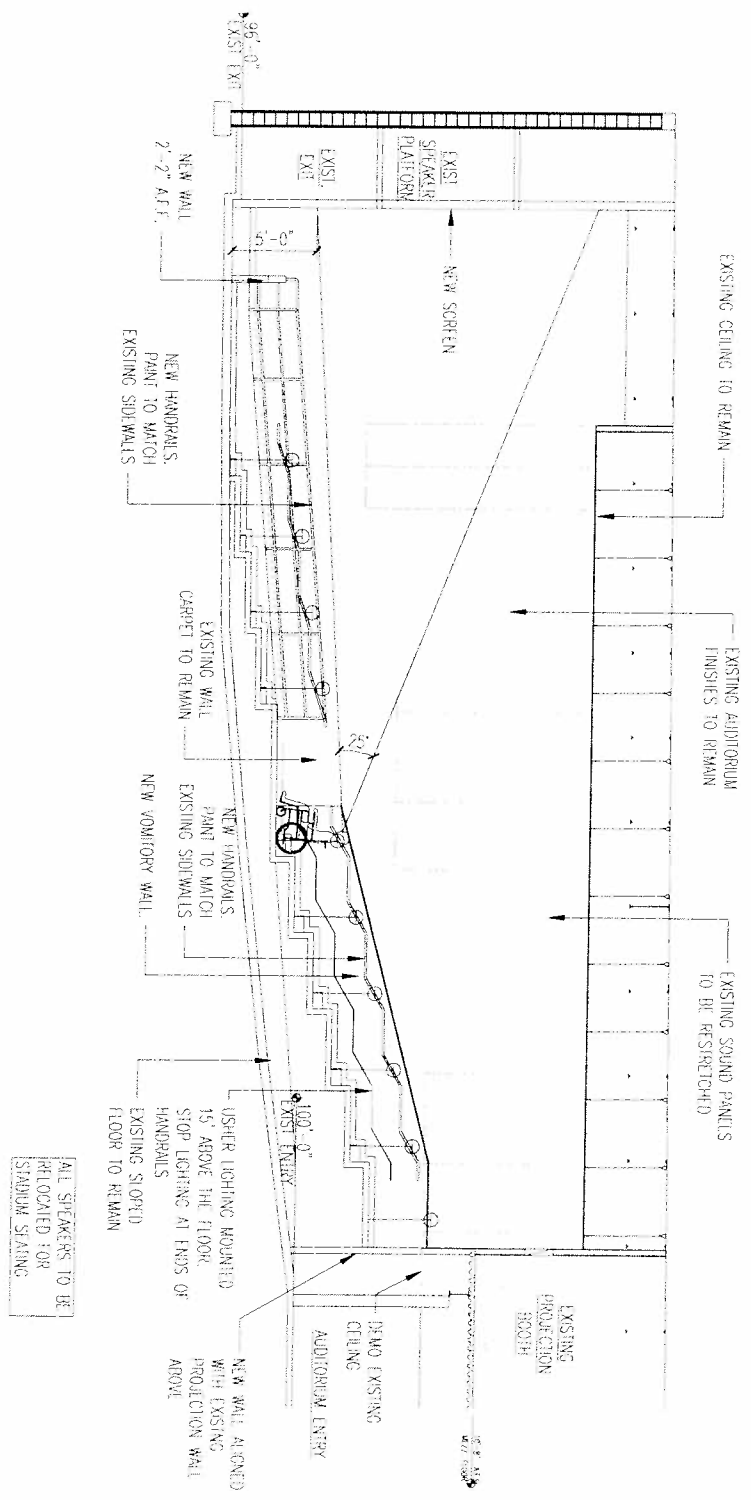

ALL SPEAKERS TO BE  
RELOCATED FOR  
STADIUM SEATING

**SECTION @ AUD. #6 (7MIRRORED)**

**TK ARCHITECTS INC.**  
TK  
106 West 11th Suite 1002  
Kansas City, MO 64105 USA  
1-816-842-1002 Fax 1-816-842-1102

**Sunrise Cinemas®**

**DEERFIELD CINEMAS INTERIOR RENOVATION**  
DEERFIELD BEACH, FL

DATE 06-15-09  
PROJECT # 08065.00  
**AUD. #6 & 7**  
SHEET No AC-12  
REFERENCE 2/AC-104

**ENLARGED AUD. #8 PLAN**

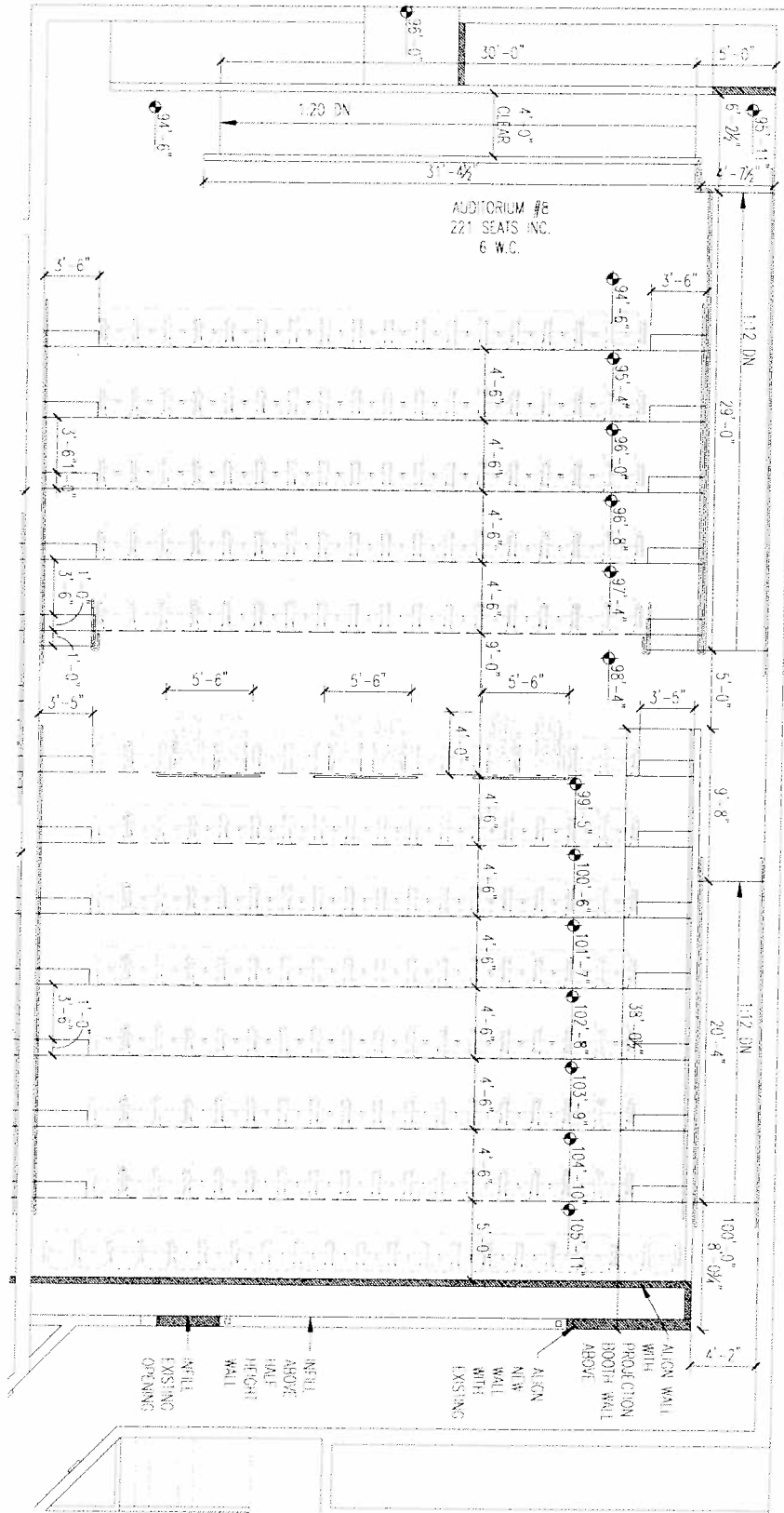

**TK ARCHITECTS INC.**

106 West 11th  
Kansas City, MO  
1 R16 R42 7552 Fax 1 R16 R42 1502

Suite 1900  
64105 USA

**Sunrise Cinemas®**

**DEERFIELD CINEMAS INTERIOR RENOVATION**  
DEERFIELD BEACH, FL

DATE 08-15-09  
PROJECT # 08065 00  
AUD. #8  
SHEET NoAC-13  
REFERENCE 4/AC-104

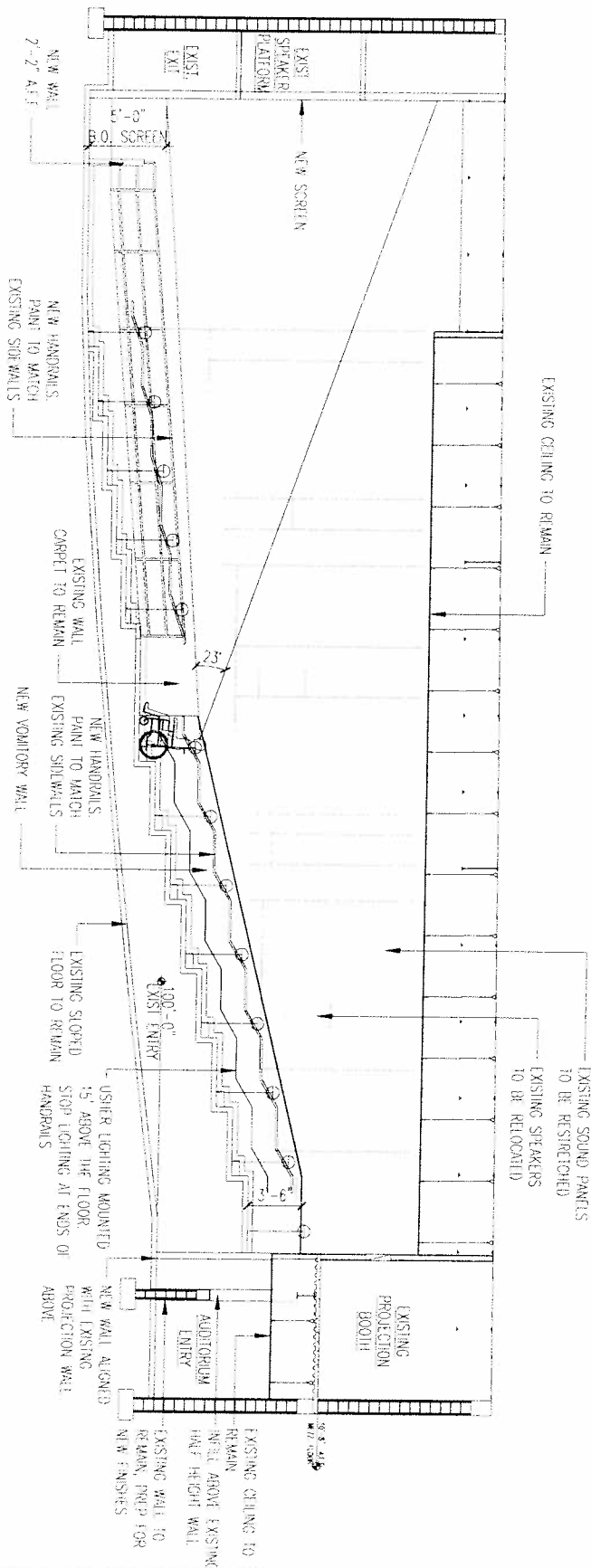

ALL SPEAKERS TO BE RELOCATED FOR STADIUM SEATING

**SECTION @ AUD. #8**



106 West 11th Suite 1900  
 Kansas City, MO 64105 USA  
 1-816-842-1352 Fax 1-816-842-1352



**DEERFIELD CINEMAS INTERIOR RENOVATION**  
 DEERFIELD BEACH, FL

DATE 06-15-09  
 PROJECT # 08065 00  
**AUD. #8**  
 SHEET No AC-14  
 REFERENCE S/AC-104



106 W. 11<sup>TH</sup> STREET SUITE 1900  
KANSAS CITY, MO 64105  
P. 816.842.7552 F. 816.842.1302

State of Florida # AA0002411

June 17, 2009

Ms. Mary-Kathryn Smith  
Department of Community Affairs  
Florida Building Division  
2555 Shumard Oak Boulevard  
Tallahassee, Florida 32399-2100  
850-410-2598

Re: Sunrise Cinema – Deerfield Mall  
TKA – 08065.00/113

Dear Ms. Smith:

We are appealing to the Accessibility Advisory Council Board to obtain a spot on the agenda for the Accessibility Advisory Council's August 10<sup>th</sup> meeting in order to receive a waiver on Florida Accessibility Codes stating that all levels in a building must be accessible to persons with disabilities. This code would require our client to install chair lifts in each individual auditorium, causing them to have a great financial hardship.

Attached you will find drawings for Sunrise Cinemas at Deerfield Mall along with the Accessibility Waiver request forms and letter describing the financial hardship that would occur, manufacturer quotes and cut sheets showing in detail the actual cost that would be incurred.

This project is a remodel of an existing (8) screen, sloped floor cinema with (130) rows and accessible seating in the rear of the auditorium, to an (8) screen, stadium seating cinema with (76) rows and accessible seating located at a central cross aisle in each auditorium.

Thank you for the consideration of a spot on the agenda at the Accessibility Advisory Council Meeting.

Sincerely,

TK ARCHITECTS, INC.

A handwritten signature in black ink that reads 'Jennifer Meyer'. The signature is written in a cursive, flowing style.

Jennifer Meyer



ARCHITECTURAL  
 CONSULTING  
 INC. 1000 17th St. N  
 Suite 1000  
 Minneapolis, MN 55403  
 Tel: 612.338.1111  
 Fax: 612.338.1112

PROJECT NO. 1000  
 SHEET NO. 1000

DOCUMENT  
 LOCK REVISION

Boji Point  
 (Towers) of  
 PL

FLOOR  
 LAYOUT  
 GROUND FLOOR  
 PL  
 Project Center  
 Dr. Klaus C.  
 NE-215

DATE: 10/11/01  
 1000 17th St. N  
 Suite 1000  
 Minneapolis, MN 55403  
 Tel: 612.338.1111  
 Fax: 612.338.1112

ASSOCIATED  
 BOJIK/AVB

