

EPIC THEATRES – DELTONA

Issue: Vertical accessibility to all rows of seats in a movie theater complex.

Analysis: The applicant is requesting a waiver from providing vertical accessibility to all rows of seats in a new, \$6,132,000 12-screen movie theater complex. The auditoriums will accommodate from 134 to 400 patrons each. The appropriate number of wheelchair seating locations and companion seats have been provided. In the small to midsize theaters, seating is located on the first level of stadium seating, while it is provided in two areas of the largest theater. Using the Means estimating process, the design professional has calculated that it would cost an additional \$2,970,800 to make all rows of seats accessible.

Project Progress:

The project is under design.

Items to be Waived:

Vertical accessibility to all rows of stadium style seats, as required by Section 553.509, Florida Statutes.

553.509 Vertical accessibility. Nothing in Sections 553.501-553.513 or the guidelines shall be construed to relieve the owner of any building, structure or facility governed by those sections from the duty to provide vertical accessibility to all levels above and below the occupiable grade level regardless of whether the guidelines require an elevator to be installed in such building, structure or facility, except for:

- (1) Elevator pits, elevator penthouses, mechanical rooms, piping or equipment catwalks and automobile lubrication and maintenance pits and platforms;
- (2) Unoccupiable spaces, such as rooms, enclosed spaces and storage spaces that are not designed for human occupancy, for public accommodations or for work areas; and
- (3) Occupiable spaces and rooms that are not open to the public and that house no more than five persons, including, but not limited to equipment control rooms and projection booths.

Waiver Criteria: There is no specific guidance for a waiver of this requirement in the code. The Commission's current rule, authorized in Section 553.512, Florida Statutes, provides criteria for granting waivers and allows consideration of unnecessary or extreme hardship to the applicant if the specific requirements were imposed.

This application is available in alternate formats upon request.

**REQUEST FOR WAIVER FROM ACCESSIBILITY REQUIREMENTS
OF CHAPTER 553, PART V, FLORIDA STATUTES**

Your application will be reviewed by the Accessibility Advisory Council and its recommendations will be presented to the Florida Building Commission. You will have the opportunity to answer questions and/or make a short presentation, not to exceed 15 minutes, at each meeting. The Commission will consider all information presented and the Council's recommendation before voting on the waiver request.

1. Name and address of project for which the waiver is requested.

Name: Epic Theatres

Address: East of Normandy Blvd / South of E. Graves Ave
Deltona, FL

2. Name of Applicant. If other than the owner, please indicate relationship of applicant to owner and written authorization by owner in space provided:

Applicant's Name: TK Architects c/o Jack Muffoletto

Applicant's Address: 106 W. 11th Street, Suite 1900 Kansas City, MO 64105

Applicant's Telephone: 816-842-7552 FAX: 816-842-1302

Applicant's E-mail Address: jmuffoletto@tkarch.com

Relationship to Owner: Architect

Owner's Name: Deltona Retail Holdings, LLC

Owner's Address: PO Box 2076
DeLand, FL 32720-2076

Owner's Telephone: 386-736-6830 FAX 386-738-2596

Owner's E-mail Address: fd@epictheatres.com

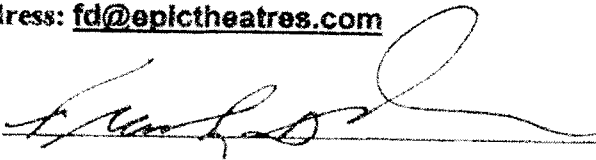
Signature of Owner: 

Contact Person: Frank DeMarsh

Contact Person's Telephone: 386-736-6830 E-mail Address: fd@epictheatres.com

This application is available in alternate formats upon request.
Form No. 2001-01

3. Please check one of the following:

New construction.

Addition to a building or facility.

Alteration to an existing building or facility.

Historical preservation (addition).

Historical preservation (alteration).

4. Type of facility. Please describe the building (square footage, number of floors). Define the use of the building (i.e., restaurant, office, retail, recreation, hotel/motel, etc.)

New Construction, 51,100 SF 12 screen Movie Theatre.

5. Project Construction Cost (Provide cost for new construction, the addition or the alteration):

\$6,132,000.00

6. Project Status: Please check the phase of construction that best describes your project at the time of this application. Describe status.

Under Design

Under Construction* In Plan Review Completed*

* Briefly explain why the request has now been referred to the Commission.

_____.

7. Requirements requested to be waived. Please reference the applicable section of Florida law. Only Florida-specific accessibility requirements may be waived.

Issue

1: 553.509, FLA Stat. (2007) which states the owner shall provide vertical accessibility to all levels above grade and below the occupiable grade level.

Issue

2: _____

Issue

3: _____

8. **Reason(s) for Waiver Request:** The Florida Building Commission may grant waivers of Florida-specific accessibility requirements upon a determination of unnecessary, unreasonable or extreme hardship. Please describe how this project meets the following hardship criteria. Explain all that would apply for consideration of granting the waiver.

The hardship is caused by a condition or set of conditions affecting the owner which does not affect owners in general.

Substantial financial costs will be incurred by the owner if the waiver is denied.

Please refer to attached letter. _____

The owner has made a **diligent investigation** into the costs of compliance with the code, but cannot find an efficient mode of compliance. Provide detailed cost estimates and, where appropriate, photographs. Cost estimates must include bids and quotes.

9. **Provide documented cost estimates for each portion of the waiver request and identify any additional supporting data which may affect the cost estimates.** For example, for vertical accessibility, the lowest documented cost of an elevator, ramp, lift or other method of providing vertical accessibility should be provided, documented by quotations or bids from at least two vendors or contractors.

a. Please refer to attached letter and attached pricing data. _____

b. _____

10. **Licensed Design Professional:** Where a licensed design professional has designed the project, his or her comments **MUST** be included and certified by signature and affixing of his or her professional seal. The comments must include the reason(s) why the waiver is necessary.

Please refer to attached letter.

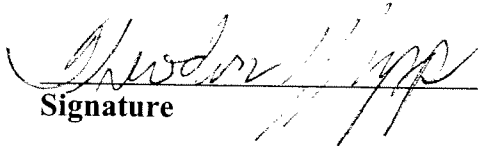

Signature

THEODORE SNAPP

Printed Name

Phone number 816 842 7552

(SEAL)

CERTIFICATION OF APPLICANT:

I hereby swear or affirm that the applicable documents in support of this Request for Waiver are attached for review by the Florida Building Commission and that all statements made in this application are to the best of my knowledge true and correct.

Dated this 3rd day of March, 20 10

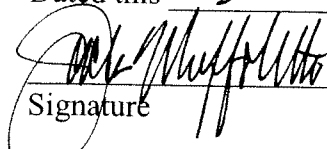

Signature

Jack Muffoletto

Printed Name

By signing this application, the applicant represents that the information in it is true, accurate and complete. If the applicant misrepresents or omits any material information, the Commission may revoke any order and will notify the building official of the permitting jurisdiction. Providing false information to the Commission is punishable as a misdemeanor under Section 775.083, Florida Statutes.

REVIEW AND RECOMMENDATION BY LOCAL BUILDING DEPARTMENT.

Please state why the issue is being referred to the Florida Building Commission as well as a recommendation for disposition. The Building Official or his or her designee should review the application and indicate that to the best of his or her knowledge, all information stipulated herein is true and accurate. Further, if this project is complete, explain why it is being referred to the Commission. The Building Official or his or her designee should sign a copy of the plans accompanying this application as certification that such plans are the same as those submitted for building department review. Please reference the applicable section of the Accessibility Code.

a. 553.509, FLA Stat. (2007) which states the owner shall provide vertical accessibility to all levels above grade and below the occupable grade level.

b. _____

c. _____

Has there been any permitted construction activity on this building during the past three years? If so, what was the cost of construction?

Yes No Cost of Construction _____

Comments/Recommendation Recommend Approval of
Waiver

Jurisdiction City of Deltona

Building Official or Designee C. Butts
Signature

Cyrus C Butts
Printed Name

BU 1401
Certification Number

386-878-8652 / FAX 386-878-8651
Telephone/FAX

Address: 2345 Providence Blvd
Deltona, FL. 32725



106 W. 11TH STREET SUITE 1900
 KANSAS CITY, MO 64105
 P. 816.842.7552 F. 816.842.1302

AA 000 2411

February 22, 2010

Request for Waiver Form
 Accessibility Requirements
 of Chapter 553, Part V
 Florida Statutes

Re: Epic Theatres
 Deltona, FL
 TKA – 09041.00/113

Item 8 from the Request for Waiver Application
Reason for Waiver Request

The requirements from which the Owner is seeking a wavier are those in the Florida Americans with Disabilities Implementation Act, Section 553.509 Florida Statutes which requires an Owner to provide vertical accessibility to all levels of a building, structure or facility. Specifically, the Owner is requesting a waiver from providing vertical accessibility to all rows of stadium seating in the movie theatre auditoriums. Section 553.512(1) Florida Statutes, provides for a waiver of the accessibility requirements set forth in Section 553.509 Florida Statutes, upon a determination of unnecessary, unreasonable or extreme hardship. Substantial financial costs will be incurred by the owner if the waiver is denied.

The Epic Theatres Deltona project is new construction of a 12 screen stadium seating movie theatre. Stadium seating is the industry standard and allows for unobstructed patron viewing of movies. Stadium seating is the issue for consideration of the Accessibility Waiver.

Each of the 12 auditoriums are comprised of tiered seating platforms of varying elevations ranging from 18" to 6" in difference between adjacent platforms. Wheelchair accessible seating locations are designed in accessible viewing locations in each auditorium with companion seating, and designed to maximize the view angle to the top of the screen to be 30° or less. Additional ambulatory accessible seating is accommodated by providing lift up arms on aisle seats. To design this theatre to provide wheelchair accessibility to every row of stadium seating will cause **extreme hardship** to the Owner as follows:

I (112) chair lifts would be required to access every row of seating:

Vertical Platform Lift Pricing

Thyssen Krupp Access.	Porch Lift Model S	\$ 8,000
Planet Mobility	Verti Lift	\$ 9,671
Adoptive Engineering	# Mobilift CX	\$10,499

We have chosen the mid-range priced lift.

Per RS Means Construction Cost Data 2006, add 8% of the material cost for installation.

Therefore, (1) Lift, furnished and installed: \$9,671 + \$774 = \$10,445

(112) Lifts furnished and installed: \$10,445 x 112 = \$1,169,840 additional cost.

II To design the physical space required for each lift, and access on each side of the lift, we have calculated that approximately 34 additional square feet per lift must be added to the building footprint.

Therefore: 34 SF x 112 lifts = 3,808 additional SF.

The preliminary building cost estimate is \$120/SF.

Therefore: 3,808 SF X \$120/SF = \$456,960 additional cost.

III Each row of seating itself, accessed by the lift, must have an accessible route to the wheelchair accessible seating location. Please note that the accessible seating location would not be on the end of a row in order to accommodate a companion. In addition, each wheelchair accessible seating location must have minimum clear floor space for a 60" turning diameter or 36" for a "T"-shaped turn. Throughout the 112 affected rows in the movie theatre, there would be roughly an additional 100 SF needed at each seating platform to be added to the building footprint or an additional 11,200/SF.

The preliminary building cost estimate is \$120/SF.

Therefore: 11,200 SF x \$120/SF = \$1,344,000 additional cost.

IV In Summary:

Additional building costs for vertical accessibility:

Platform Lifts (112) Material & Labor	\$ 1,169,840
--	--------------

Platform Lift SF Additional 3,808 SF	\$ 456,960
---	------------

Accessible Seating Rows (112) Additional 11,200 SF	\$ 1,344,000
<hr/> Total Financial Hardship:	<hr/> \$ 2,970,800

Compared to the original building cost estimate:

51,100 SF x \$120/SF =	\$ 6,132,000
------------------------	--------------

New Total:	\$ 9,102,800
------------	--------------

Or about a 48% cost increase.

It is not practical to provide vertical accessibility to each level of stadium seating, due to the high cost of providing multiple lifts for the requirements of ADA Section 4.33.3 which states that the seating shall adjoin an accessible route that also serves as a means of egress in case of emergency.

As it is not practical to achieve this in a stadium seating-style movie theatre, we have provided a solution:

- 1) To meet the required quantities of disabled seating locations.
- 2) To include a companion seat for each disabled seating location.
- 3) And provide a maximum view angle to the top of the screen to be 30° or less. The 30° view angle situates the disabled seating locations at or about in the center of the auditorium achieving comparable sight lines for patrons.

Prepared by,

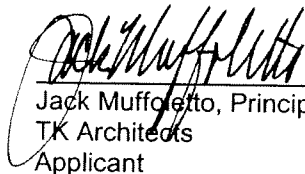

Jack Muffoletto, Principal
TK Architects
Applicant

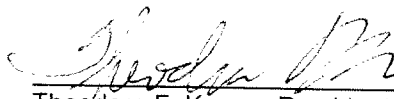

Theodore F. Knapp, President
TK Architects
Design Professional

Porch-Lift®

Commercial Vertical Platform Lifts

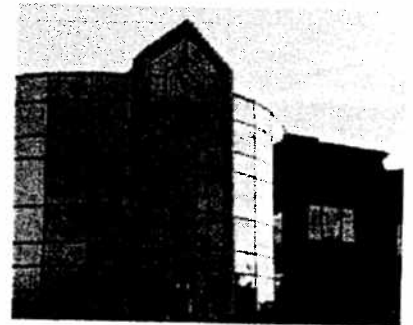
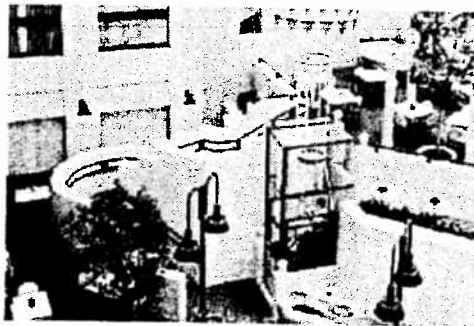
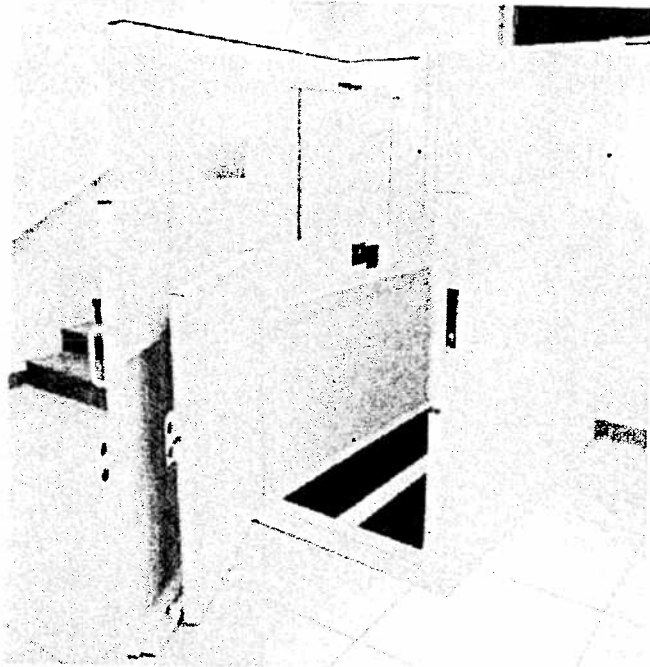

ThyssenKrupp Access

Accessibility Division



ThyssenKrupp

Function and design become one statement for your building

For 60 years, ThyssenKrupp Access has provided unparalleled versatility in accessibility solutions and fully complies with the ADA Accessibility Guidelines (ADAAG). You can be assured that whatever design, structural or budget challenge you face, ThyssenKrupp Access has a variety of product solutions that will fit your specific needs.

Why a vertical platform lift?

Vertical platform lifts (VPL) are the most popular alternative to unsightly ramps and, in some cases, to low rise elevators. These lifts overcome architectural barriers with cost and space efficiency as they lift a person just a few inches to heights of up to 14 feet.

Our Porch-Lift VPLs are proven performers, providing access without the headaches and costs of constant repairs. And we back our Porch-Lifts with a full two-year drive train and one-year parts warranty.

Why choose ThyssenKrupp Access?

Expertise

We have assembled the largest engineering, research, and design staff in the industry dedicated to bringing you products that meet your growing accessibility needs. They are ready to work with you to assist with product customization to meet the most demanding design and application needs. If you have an accessibility problem, there is no other group of people more capable and committed to helping you...it's our tradition.

Convenience

It's easy to include a Porch-Lift VPL in your project. Call for a free CD-ROM or go online for complete CSI specifications, insertable CAD details, comparison charts and more.

Compliance

Our lifts conform to specifications established by the ASME A18.1 (formerly A17.1, Parts XX & XXI). The lifts carry the prestigious Underwriters Laboratories label when appropriately equipped.

While our lifts meet national standards, consult local authorities to establish local code requirements before ordering or specifying a lift. Our nationwide dealer network is well versed in ADAAG and ASME/ANSI requirements and can help ensure compliance with state and local codes.

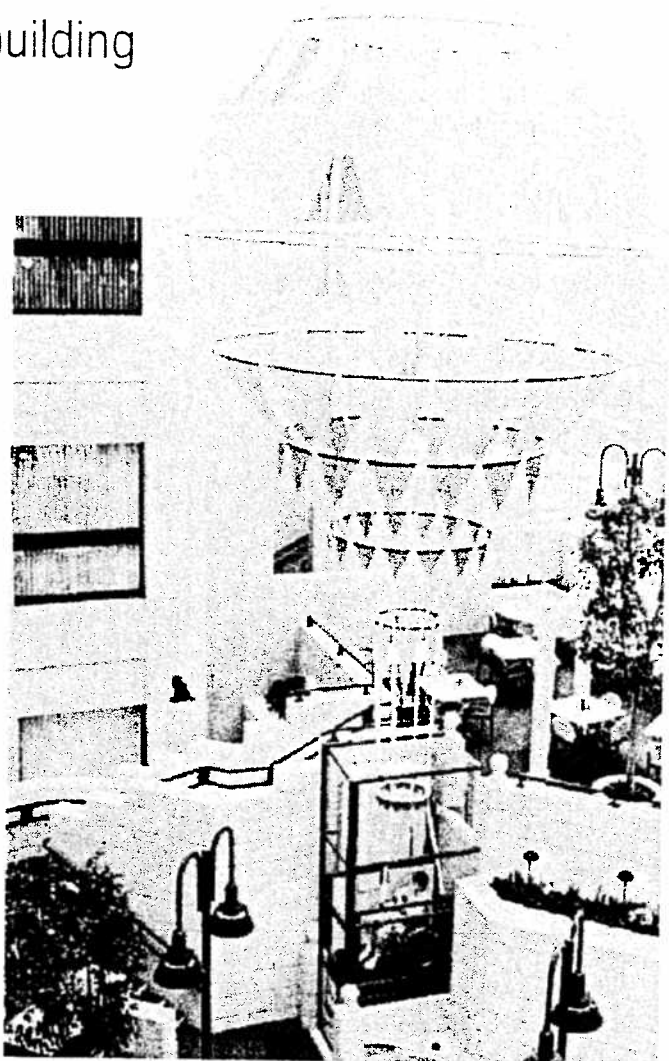

A hospital needed to provide access to its raised dining area. Architects worked closely with our design engineers to custom design and fabricate a Porch-Lift to look like a spectacular balloon to enhance the appearance of their atrium (hoistway by others).

Five models to choose from:

- **Standard**—Many times this product is encased in a hoistway to provide solutions from the simplest to the most sophisticated design.
- **Toe Guard**—Stationary panels surround and protect the underside of the platform without a hoistway, which means minimal structural changes to your facility.
- **Enclosure**—The lift is enclosed throughout its entire travel in an aluminum frame and acrylic panel hoistway.
- **EZE Enclosure**—This economical lift is enclosed by a modular steel or aluminum frame enclosure with steel or acrylic panels.
- **Portable**—Provides temporary wheelchair accessibility.

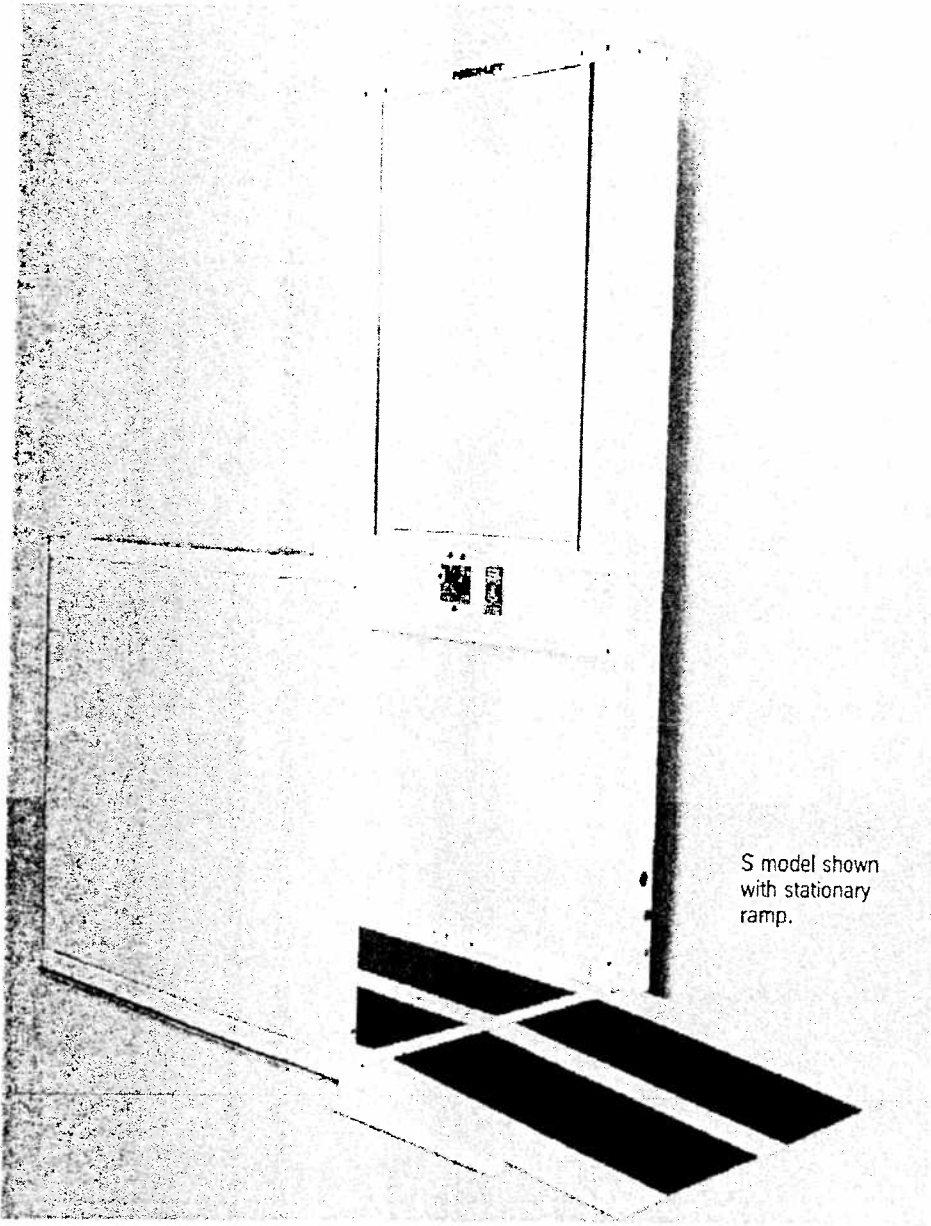

S model shown with stationary ramp.

Porch-Lift® Standard Model (S)

The most popular lift for custom designs.

The popular PL-S model can be easily customized to blend with surrounding interiors and exteriors. Your dealer can install the lift in a hoistway that blends with surroundings, or completely concealed (hoistway by others). A selection of hoistway door and gate options available from ThyssenKrupp Access or from your contractor let you tailor the hoistway appearance to meet your architectural needs.

Typical Dimensions (Top view with 36"x48" platform)

S Model	Lift Height
S 36	39"
S 50	53"
S 72	75"
S 96	99"
S 120	123"
S 144	147"
S 168	171"

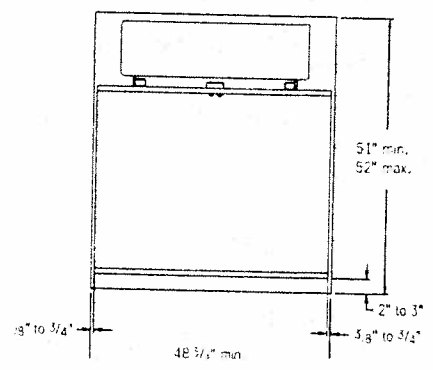
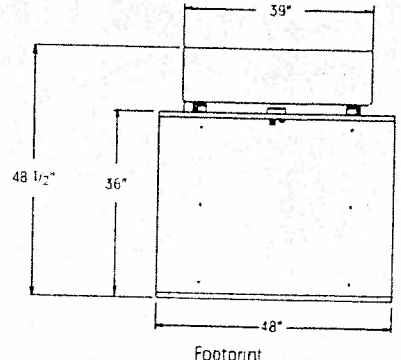

Corporate Headquarters: Two-stop hoistway features a clear and frosted custom glass door at the lower landing.



Elementary School: A lift in a fully enclosed hoistway provides lower level access for a kindergartner.

Porch-Lift® Toe Guard Model (TG)

The lift with Toe Guard protection meets codes without a hoistway.

This freestanding model provides access to your building with minimal construction, as no hoistway is needed for ADA compliance. Stationary lower landing walls and gate shield the underside of the platform as the platform rises in a telescoping movement.

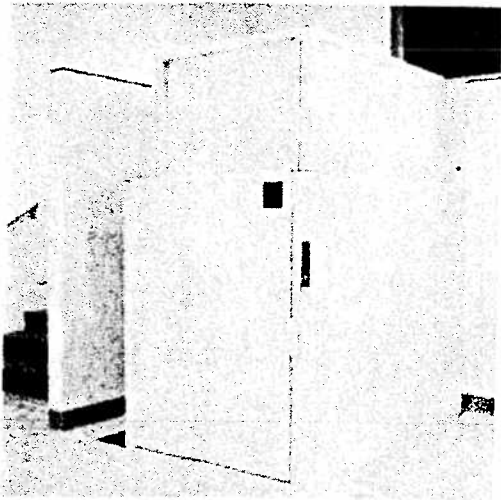
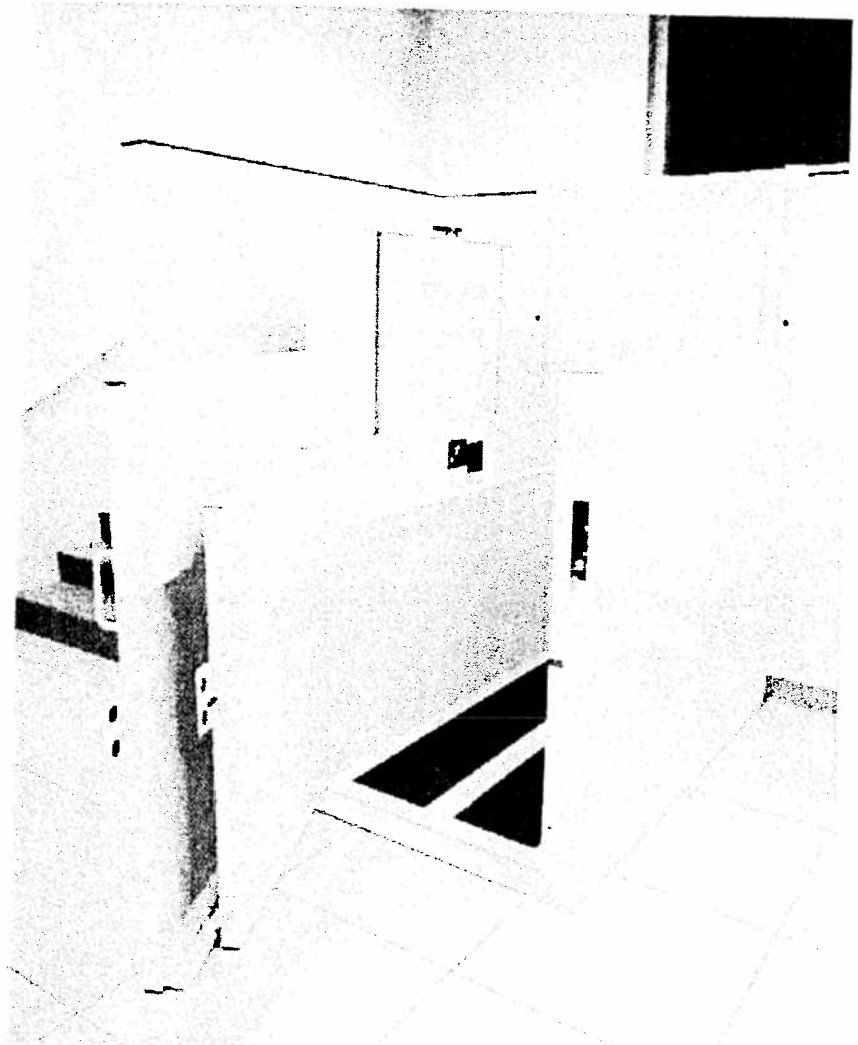

The "toe guard" feature works as a hoistway. Interlocks prevent the gate from opening until the lift has arrived at that level.

Typical Dimensions
(Top view with 36"x60" platform)

Toe Guard Model	Lift Height
TG 50	52"



Medical Center: The rear parking lot was on a different level from the main floor of this medical center. The Porch-Lift provided a convenient way for patients to get from one level to the other.

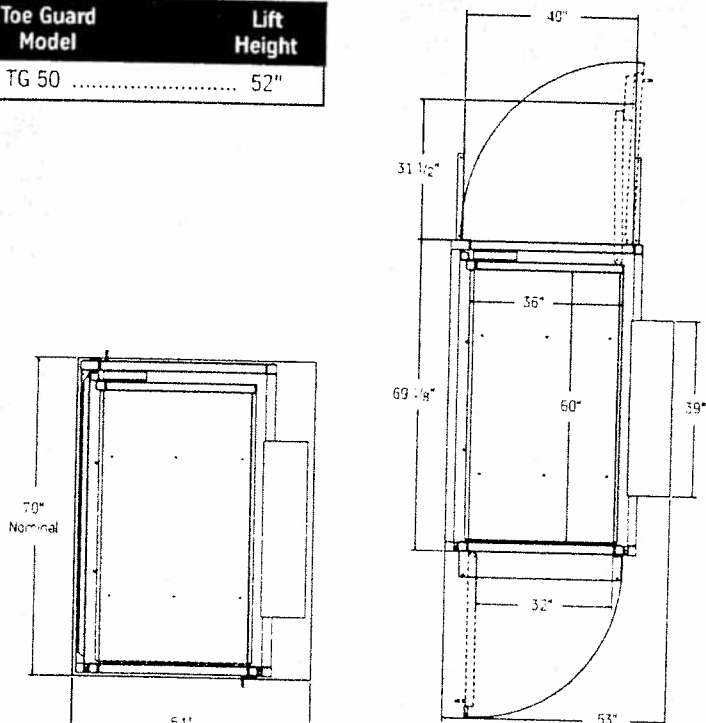

Porch-Lift® Enclosure Models

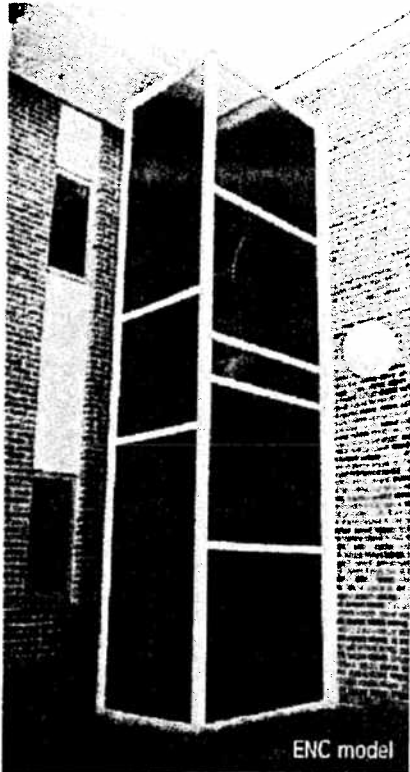

ENC model

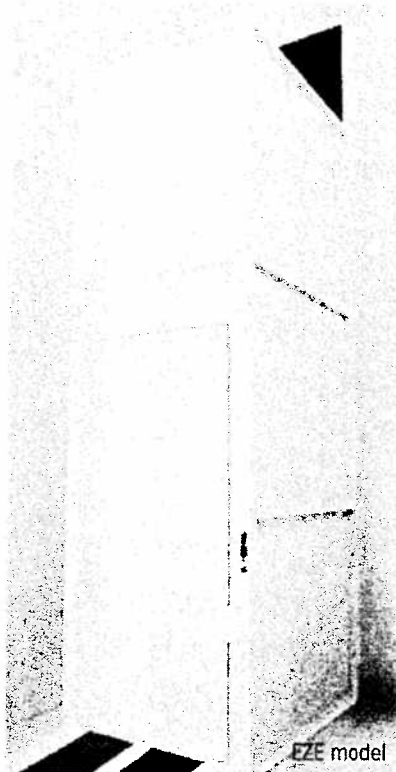

EZE model

The ENC 2.0 model with a stylish enclosure

The ENC model includes a modular aluminum enclosure, ideal for indoor or outdoor use, and gives you an elegant, turnkey installation without the cost and space needs of a contractor-built hoistway.

- Corrosion-resistant aluminum hoistway frame is maintenance-free. Fasteners are hidden for a clean, contemporary look.
- Shatterproof translucent acrylic panels in sides and doors give optimum visibility, or select high-pressure laminate panels.
- A full height door is provided at the lower landing and, for three-stop lifts, at the intermediate landing. A door or gate can be selected for the top landing.
- Select tinted windows, ventilation package, and acrylic dome for exterior installations for weather protection.

The simple EZE enclosure

This flexible enclosure model is uniquely engineered to quickly provide maximum access to your facility with minimal site preparation. Select the steel frame for indoor applications, or for outdoor use choose the corrosion-resistant aluminum frame with acrylic panels and ventilation package.

- Select tinted windows, ventilation package, and acrylic dome for exterior installations for weather protection.

Typical Dimensions (Top view with 36"x60" platform)

Enclosure Models	Lift Height	
	ENC	EZE
ENC/EZE 50.....	53".....	52"
ENC/EZE 72.....	75".....	74"
ENC/EZE 96.....	99".....	98"
ENC/EZE 120.....	123".....	122"
ENC/EZE 144.....	147".....	146"
ENC/EZE 168.....	171".....	170"

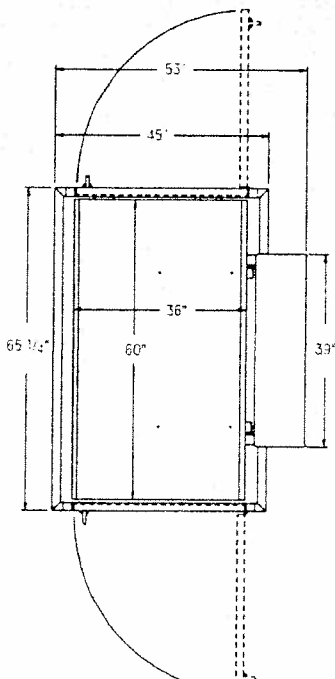
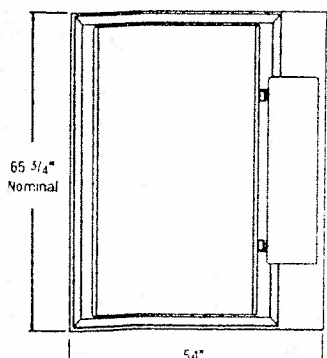

(left) Choose a door or gate for the upper landing, and add an optional Auto-Opener™ for maximum convenience. The lift interior shown here is with acrylic panels and fixed access ramp.

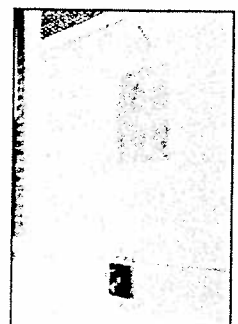

(right) Select the forced air ventilation package, which includes automatic fan, battery backup, and emergency light for passenger comfort and safety.

Porch-Lift® Portable Model (P)

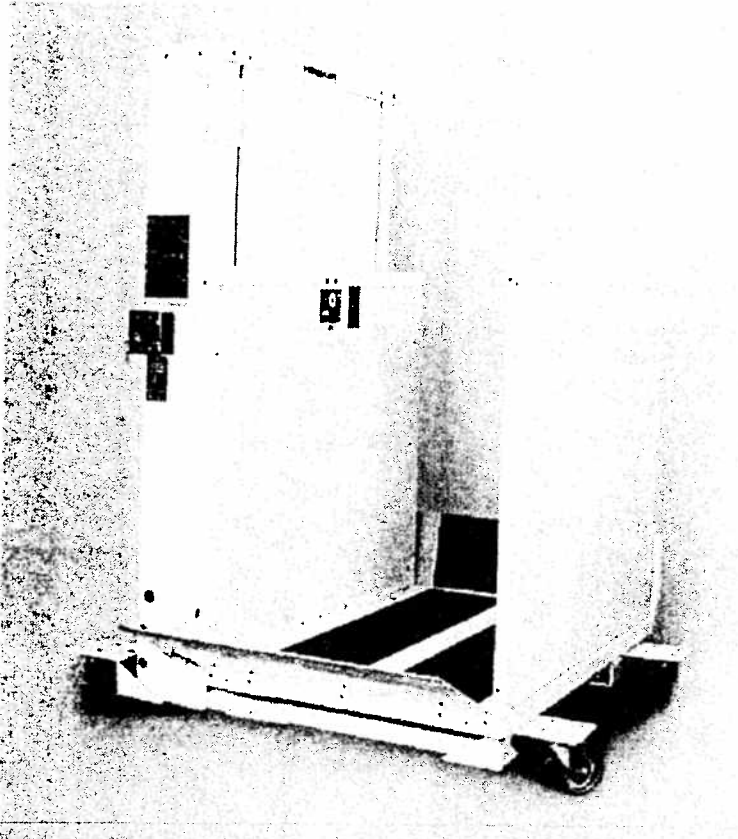

This model provides temporary wheelchair accessibility at special events, stages, courtrooms and other venues where the need for access occurs only occasionally.

- Standard with four wheels, which attach to the frame base for easy maneuverability. A lifting lever and support block assist in the installation and removal of wheels.

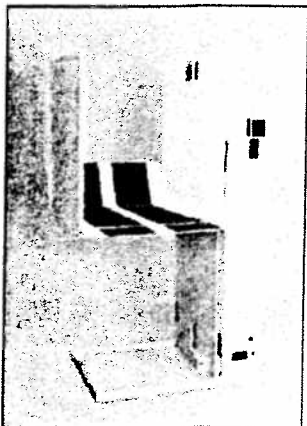

A 10" ramp automatically unfolds when it has arrived at the upper landing. A 15" automatic folding ramp provides access at the lower level.



An adjustable switch allows you to choose the right lifting height to suit your needs. The model lifts up to 6 feet.

Customize your Porch-Lift® to meet your unique needs.

Gates and doors

Your dealer can assist you in selecting a factory supplied top gate and UL fire rated doors tailored to your application. Your contractor can also furnish custom gates and doors to coordinate with the building interior or exterior. Optional clear or bronze tinted acrylic panel inserts are available.

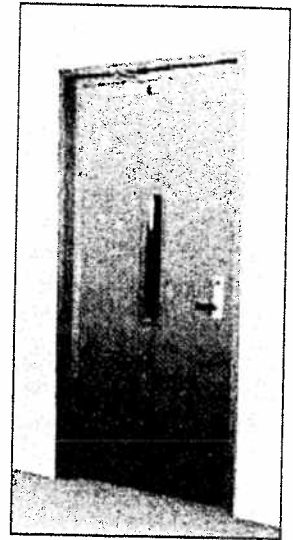

Flush mount 1 1/2 hour fire rated door

AutoOpener™

An automatic power door/gate opener option is available for unassisted access at the press of a button.

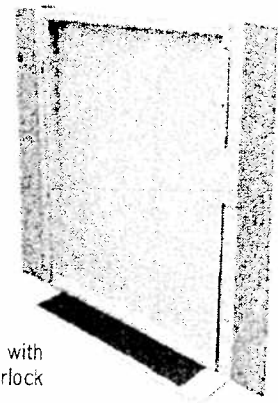

42" high top landing gate with VDR™ mechanical interlock



Standard controls on the lifts include a constant-pressure directional paddle, an emergency stop button, illuminated alarm button, and a key lock to secure against unauthorized access.

Convenient remote controls can be mounted on or near the lift or in the gate or door frame giving

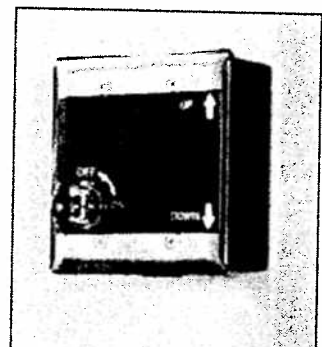

Hoistway Configurations:

Porch-Lift S model vertical platform lifts are often installed inside of hoistways. Below are popular configurations.

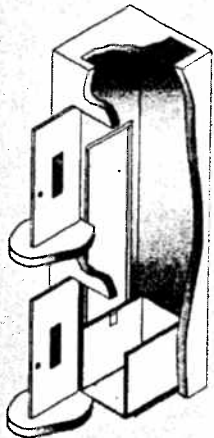

Enter/exit same side

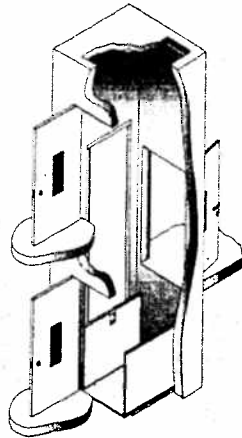

Three stop

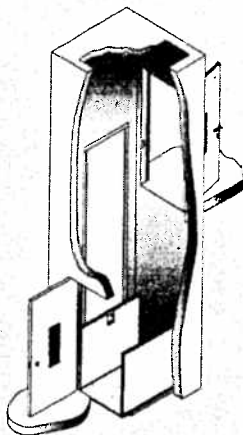

Enter/exit straight through

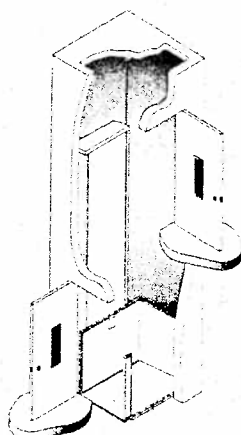

90° side exit

Finish colors

Ivory powder coat is the standard finish color. Powder coating is more durable than typical paint, protecting the lift and adding years of beauty. Or you may select one of 180 special colors.



Ivory (standard)

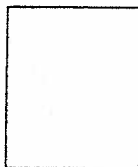

Taupe

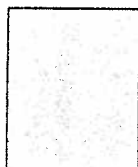

Pearl gray



Sable brown

Special order colors
(from RAL color chart)

Three operating systems

- A/C power recirculating ballscrew drive.
- Battery power recirculating ballscrew drive.
- Battery power 1:2 roped hydraulic drive.

Battery operation ensures dependable, uninterrupted service even in the event of a power failure. Our exclusive SmartCharge™ technology automatically recharges the batteries as needed.

Common features:

- Mechanical interlocks prevent lift operation until gates and doors are closed and locked.
- Two mounting configurations: floor mount with a ramp, or pit mount—which eliminates the need for a ramp.
- Multiple platform sizes with non-skid surfaces to meet varying space and use requirements.
- Three platform enter/exit configurations: same side, straight through, or 90° side exit.
- All models are designed for indoor or outdoor applications.
- Conveniently located platform controls for easy operation.
- Remote controls enable the lift to be operated from all landings.
- Security key locks prevent unwanted use.
- Ivory powder coat is the standard finish color.
- Warranty: Drive train carries a two-year limited warranty and component parts carry a one-year limited warranty.

Site preparation by others

In order to prepare the site for installation, others must complete the following:

- 1) 115V, single phase. 20 amp electrical connection for lift with disconnect switch.
- 2) All lighting.
- 3) Construction of a 4" thick, 3500 PSI, level, reinforced concrete pad which the lift base will be anchored.

Visit our web site at www.tkaccess.com for more information including complete 3-part specifications, CAD details, and typical drawings.

Specifications and/or colors subject to change without notice.

Porch-Lift Specifications/Options	Model				
	S	TG	ENC 2.0	EZE	P
Rated load:			750 lbs.		
Speed with rated load: ballscrew drive optional hydraulic drive			9-12 fpm 18-21 fpm		9-12 fpm
Power supply:			115 VAC, 60 Hz, 20 amp		
Motor:			A/C ballscrew: 1/2 hp, 120 VAC, 60 Hz reversible D/C ballscrew: 1/2 hp, 24 VDC, reversible D/C hydraulic: 3/4 hp motor, 24 VDC		A/C ballscrew: 1/2 hp, 120 VAC, 60 Hz
Drive system: A/C powered ballscrew Battery powered ballscrew Battery powered hydraulic	Standard Optional Optional	Standard Optional Optional	Standard Optional Optional	Standard Optional Optional	Standard n/a n/a
Platform sizes:	36"x48" Std, 36"x56" Opt, 36"x60" Opt, 42"x60" Opt (90° only)	36"x60" Std, 36"x48" Opt	36"x60" Std	36"x60" Std	36"x48" Std
Platform configurations: Straight-thru 90° side exit Enter/exit same side	Standard Optional Optional	Standard Optional n/a	Standard Optional Optional	Standard Optional Optional	Standard n/a n/a
Platform controls:	Constant pressure paddle with key lock and emergency stop and alarm				
Maximum lifting height:	14'-3"	4'-4"	14'-3"	14'-2"	6'-3"
Maximum stops:	3	2	3	3	2
Remote controls with key lock:	Optional	Standard	Optional	Standard	Standard
Ivory powder coat finish:	Standard	Standard	Standard	Standard	Standard
42" high guard panels:	Standard	Standard	Standard	Standard	Standard
Grab rail:	Standard	Standard	Standard	Standard	Optional
Select from gates or standard-sized doors, including fire-rated doors and extra wide gates:	Optional	Optional	Optional	Optional	n/a
Fixed access ramp, or optional automatic folding ramp for applications where there is no pit:	Standard	Standard	Standard	Standard	Powered auto
Over 180 custom colors:	Optional	Optional	Optional	Optional	Optional
Acrylic guard panel inserts:	Optional	Optional	Optional	Optional	n/a
Auto-Opener™ for doors and gates:	Optional	Optional	Optional	Optional	n/a
Attendant operated package:	Optional	n/a	n/a	n/a	n/a
Telephone jack on platform:	Optional	Optional	Optional	Optional	n/a
Warranty: 2 year drive train, 1 year parts:	Standard	Standard	Standard	Standard	Standard
UL/ETL listed up to 168" lifting height:	Standard	Standard	Standard	Standard	n/a
ASME A-18.1 code compliant:	Standard	Standard	Standard	Standard	n/a



ThyssenKrupp Access has teamed with Ron Blank & Associates to become a Continuing Education System (CES) provider.

This is a free face-to-face based, Lunch and Learn program where your designers will learn ADA standards for Wheelchair Lifts and Limited Use Limited Application (LU/LA) Elevators. Course credits are automatically reported and a course report and certificate of completion are automatically provided. For more information, go to www.tkaccess.com/ces or call our Architectural & Engineering Representatives at 800-925-3100 Ext 5472.

Committed to improving the quality of life. ThyssenKrupp Access, the world's most trusted name in accessibility and home elevator solutions.

Manufactured in USA since 1947.



\$8,000 average per 6/24 phone conversation with Steve Robinson Kansas City mfg. rep.
Jim Jeshonek will be the Florida mfg rep.

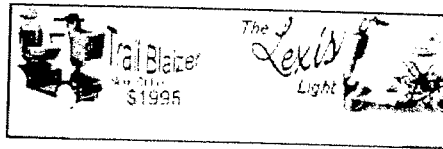

Showroom

Commercial Wheelchair Lift

Commercial

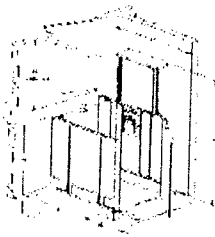

Planet mobility wheelchair lifts allow people with mobility issues to remain active, improving the quality of life. It's there personal freedom, and that is important to us That is our job.

Safety, comfort and convenience were Planet Mobility's #1 design considerations.

Features

- Innovative Soft Touch Control Pads for ease of operation.
- Direct drive Worm-Gear / Screw-Nut Drive for maintenance free operation, incorporating zero load start for cold weather climates (drive system allows motor to get up to full speed before lifting car).
- Expanded Metal Platform allows full under platform visibility.
- Keyed Emergency Stop to control use of lift.

Smooth and quiet performance makes this light weight, dependable and versatile unit perfect for any residential or commercial application.

Our High Tower Lift's will go as high as 12' Feet and can be used with many applications.

"Straight Trough": Straight through application means that the lift would be entered by one side and after raising and reaching the destination landing would be exited on the opposite side.

"Adjacent Access": Adjacent access application means that the lift would be entered by one side and after raising and reaching the destination landing would be exited to the right or left.

"Same Side": Same side application means that the lift would be entered by one side and after raising and reaching the destination landing would be exited at the same location it was entered.

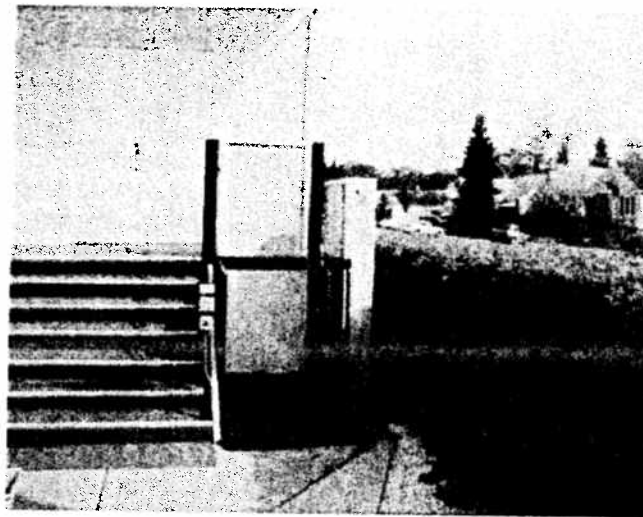

Technical Specifications

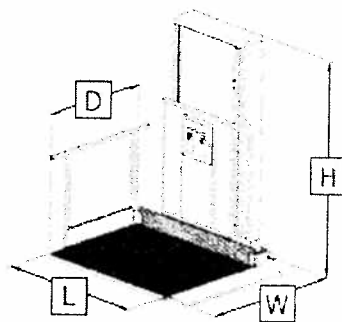

Adjacent Access

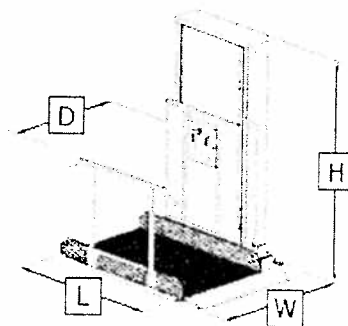

Straight Through Access

Deck Dimensions (L, D, W)

Access	L Deck Length	D Deck Width	W Total Width
Straight Through Access	54" (1372 mm)	34" (864 mm)	48" (1219 mm)
Adjacent Access	54" (1372 mm)	40" (1016 mm)	54" (1372 mm)

Tower Dimensions (H)

--	--

Total Travel	H Tower Height
28" (711 mm) Lift Height	48" (1219 mm)
52" (1321 mm) Lift Height	72" (1829 mm)
72" (1829 mm) Lift Height	92" (2337 mm)
96" (2438 mm) Lift Height	118" (2997 mm)
120" (3048 mm) Lift Height	142" (3607 mm)
144" (3658 mm) Lift Height	166" (4216 mm)

Technical

- Constant pressure Soft Touch control pads
- 550 pound (250-kg) lift capacity
- Constant pressure Soft Touch control pads
- 8 feet/minute lift speed
- Direct worm gear/acme screw drive
- Non-load-bearing backup safety nut on lift shaft
- Low maintenance
- Expanded metal platform with full under platform visibility and non skid surface
- 8" positive action, reversible toe-plate for universal access
- Emergency manual operation
- Fuse box accessible from carriage
- Quick and easy set-up and adjustment
- Baked on Powder Coat finish
- Baked on Powder Coat finish
- Extreme Weather resistant design
- U.L. and C.S.A. Certified

Options

- Under platform safety plate and solid platform
- Carriage gate
- Landing gates
- Portable model
- Solid Hand Rail
- 12V DC battery backup
- 18" extra wide toe plate
- Remote call stations
- Electric Interlocks

[Commercial Lift - High Tower Lift - Residential Lift - Photos](#)

[View Drawings And Pricing Here.....!](#)



Tell a friend:

(866) GO-LIFTS

Toll Free: (866) 465-4387

Phone: (586) 247-8900

14986 Technology Drive Fax: (586) 247-3435 Shelby TWP. MI 48315

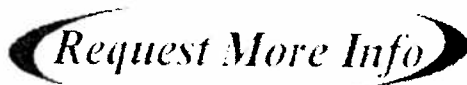

Planet Mobility Main Menu! - Online Mall

Bathroom	Beds	Bikes	Ceiling Lifts	Commode Lifts	Cushions
Door Openers	Elevators	Fitness	Hand Bikes	Lift Chairs	Patient Lifts
Phones	Pool Lifts	Ramps	Seat Lifts	Scooters	Scooter Lifts
Slings	Stairway Lifts	Standing Frames	Tie Downs	Transfer Lifts	Walker
Wireless	Wheelchairs	Wheelchair Lifts	Specials	Search	Main Menu!

14986 Technology Dr Shelby Twp. Mi. 48315 (866) 465-4387 Fax: (586) 532-8279 www.planetmobility.com

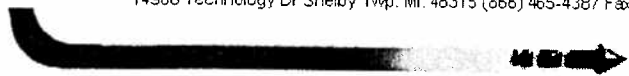

Search Site [Help](#) [Advanced Search](#)

[Home](#) [News](#) [Warranty](#) [Classifieds](#) [Dealers](#) [Store](#) [Rent It](#) [Shipping](#) [Sign Up](#) [Contact Us](#)



Trail Blazer
 The Lexis Light
 \$1995.
 Toll Free: (866) 465-4387



Showroom

[View Cart & Checkout >](#)

Verti Lift Pricing

~~Retail Price: \$9998.~~
Planet Price: \$5998.

Verti Lift High Performance Wheelchair Lift

Qty: 1

Please Select Model:

Verti-Lift V L-1 34x54 \$5998.

Please Select Travel:

96 Inch Travel \$2998.

Electronic Interlocks:

None

Please Select Call Send Buttons:

None

Full Height Flush Mount Pre Hung Fire Rated Doors:

None

Upper Landing Gate \$675.

Under Car Safety Plate \$248.

Carriage Gate \$489.

Seat On Platform \$189.

Hands Free Phone \$289.

\$	5,998
\$	2,998
\$	675
<hr/>	
\$	9,671

[Add To Shopping Cart](#)

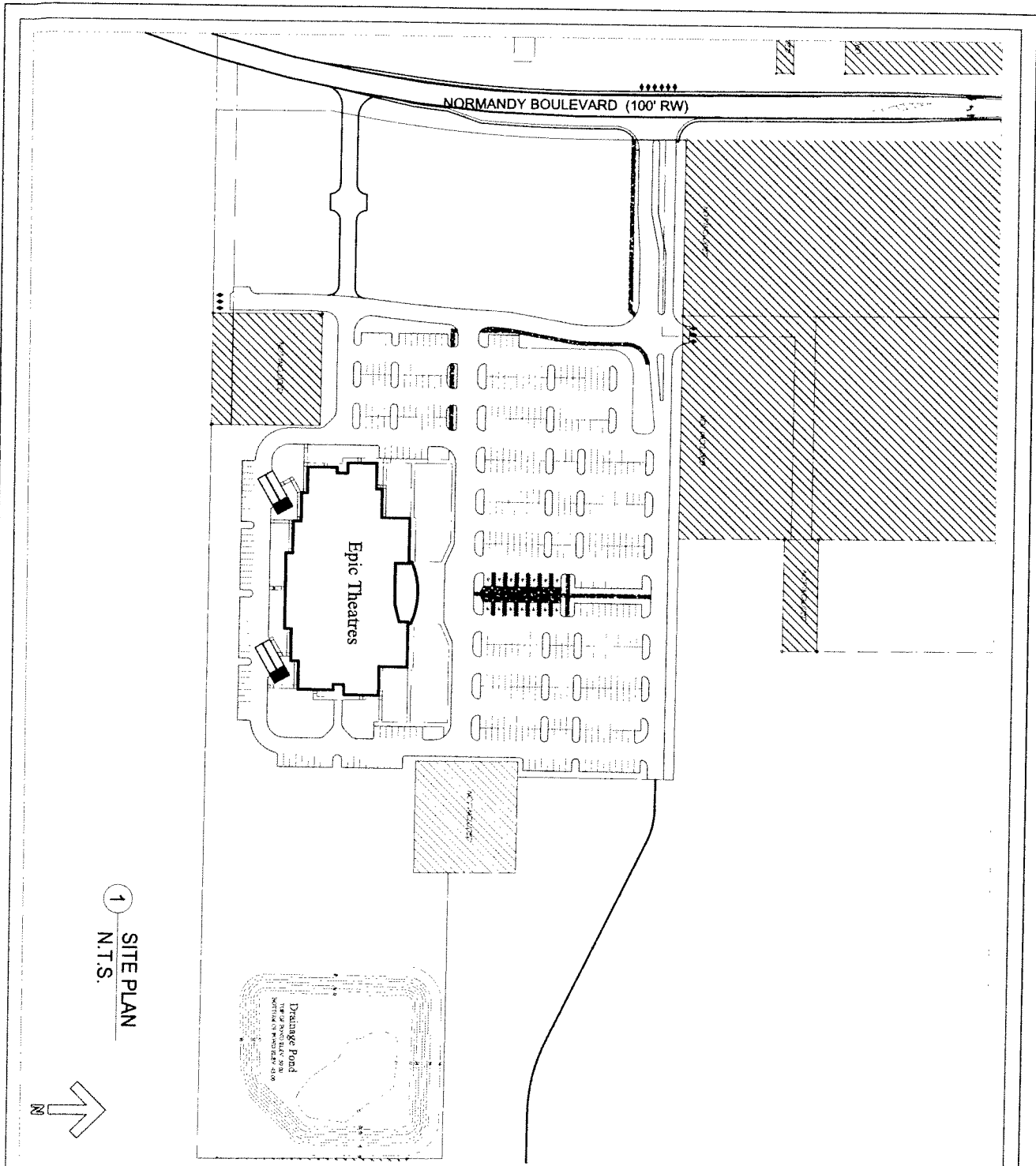

1 SITE PLAN
N.T.S.



AC-1

DATE 02-26-10
PROJECT 9041

EPIC
DELTONA, FL
ADA WAIVER



106 West 11th
Street, Suite 1900,
KC, MO 64105
PH (816) 842-7552
Fax (816) 842-1302



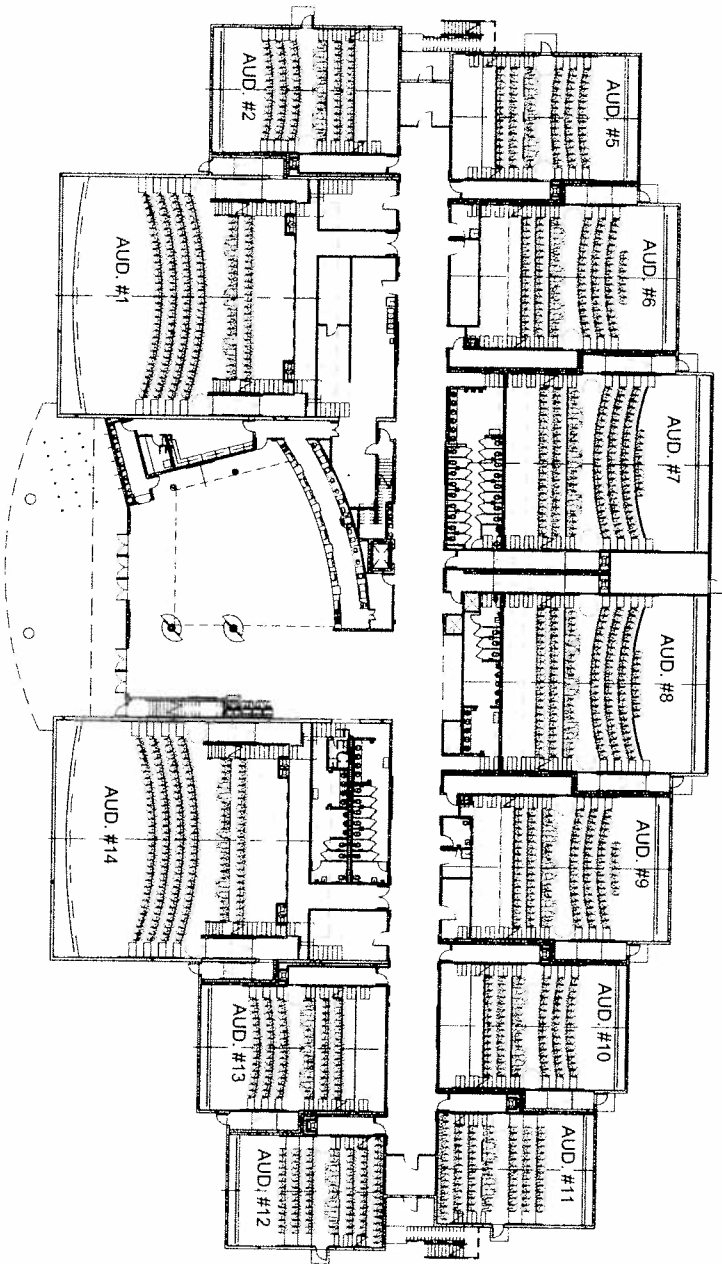

1 FIRST FLOOR PLAN
 1" = 40'-0"

<p>TKK ARCHITECTS</p> <p>106 West 11th Street, Suite 1900, KC, MO 64105 PH (816) 842-7552 Fax (816) 842-1302</p>	<p>EPIC THEATRES</p>	<p>EPIC DELTONA, FL ACCESSIBILITY WAIVER</p>	<p>DATE 02-26-10 PROJECT 9041</p>	<p>AC-2</p>
---	-----------------------------------	--	--	-------------

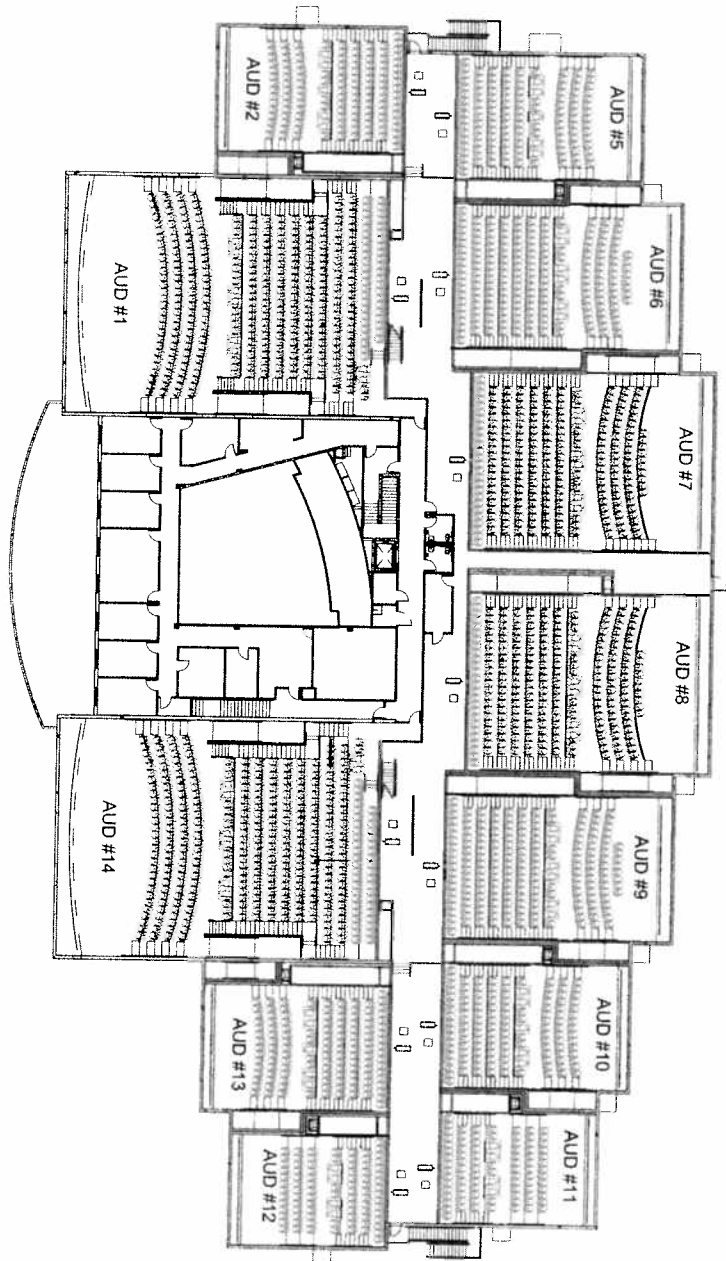

1 MEZZANINE PLAN
 1" = 40'-0"

TK
 THEATRES

106 West 11th
 Street, Suite 1900,
 KC, MO 64105
 PH (816) 842-7552
 Fax (816) 842-1302

EPIC
 THEATRES

EPIC
 DELTONA, FL
 ACCESSIBILITY WAIVER

DATE 02-26-10
 PROJECT 9041

AC-3

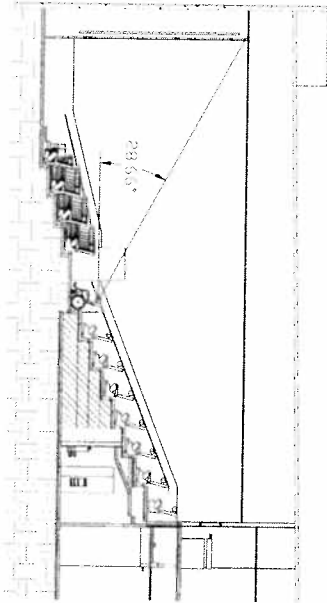

4 AUD. #7 & #8 MEZZANINE PLAN
1/16" = 1'-0"

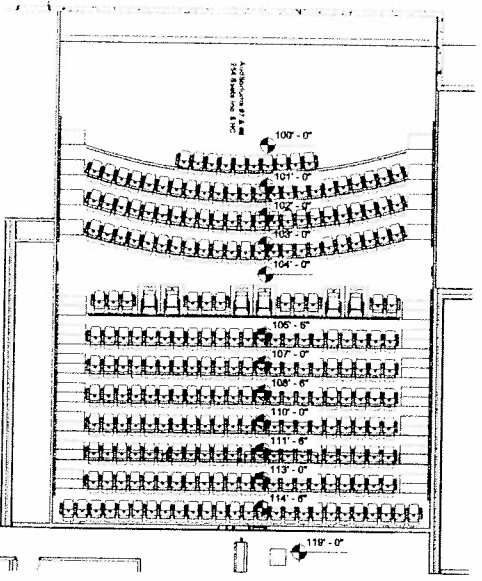

3 AUD. #7 & #8 MEZZANINE PLAN
1/16" = 1'-0"

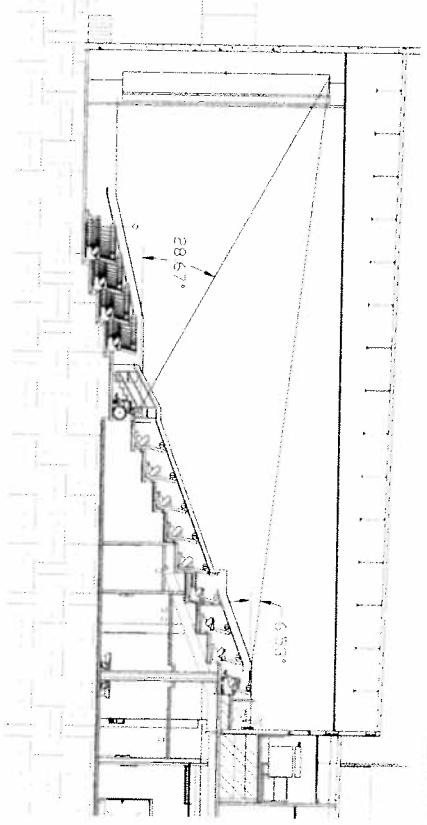

2 AUD. #1 & #14 MEZZANINE PLAN
1/16" = 1'-0"

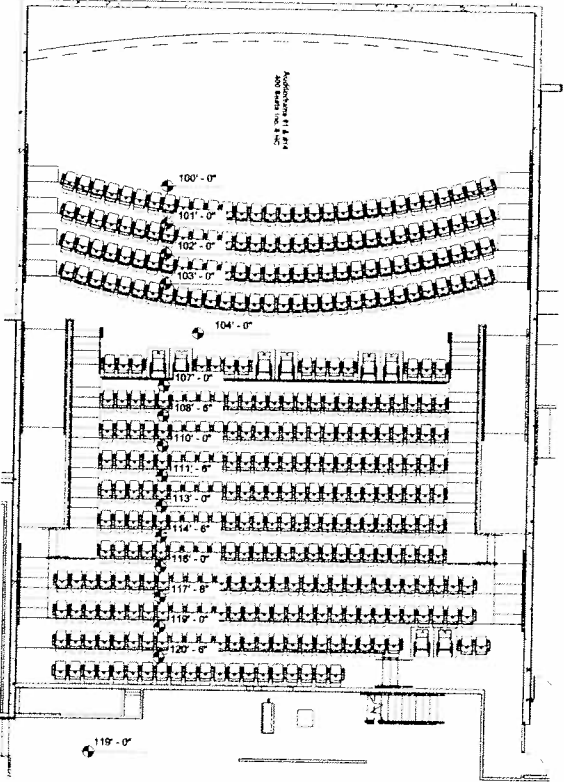

1 AUD. #1 & #14 MEZZANINE PLAN
1/16" = 1'-0"



KC. MO 64105
PH (816) 842-7552
Fax (816) 842-1302



EPIC
DELTONA, FL
ACCESSIBILITY WAIVER

DATE 03-03-10
PROJECT 9041

AC-4

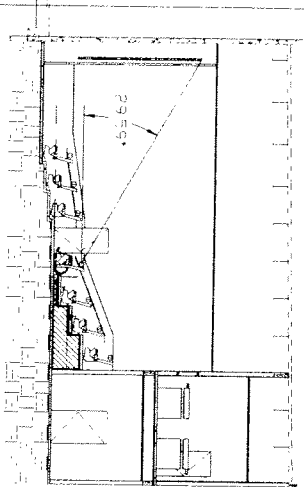

6 AUD. #11 & #12 SECTION
1/16" = 1'-0"

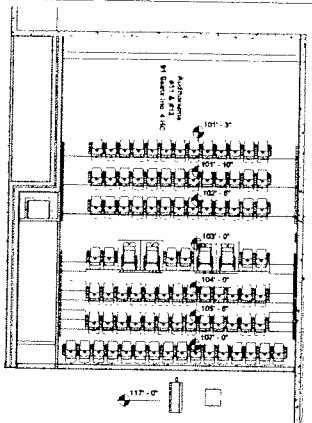

C AUD. #11 & #12 MEZZANINE PLAN
1/16" = 1'-0"

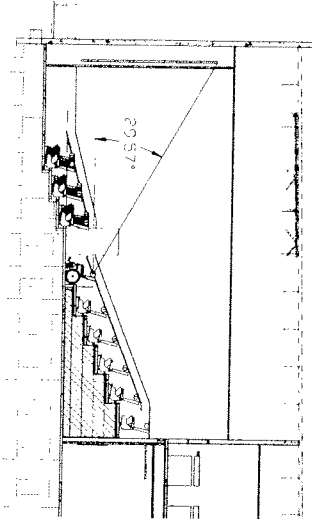

4 AUD. #2, #5, #10 & #13 SECTION
1/16" = 1'-0"

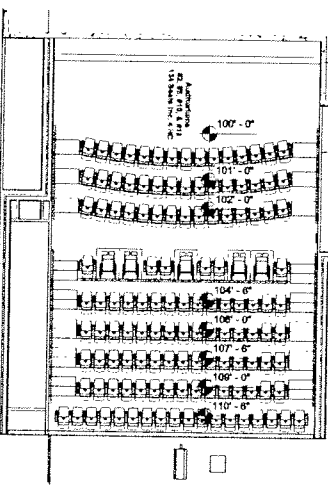

B AUD. #2, #5, #10 & #13 MEZZANINE PLAN
1/16" = 1'-0"

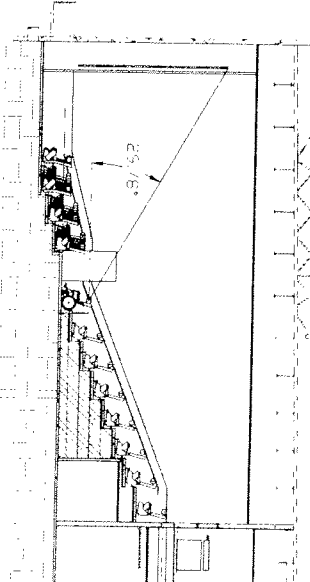

2 AUD. #6 & #9 SECTION
1/16" = 1'-0"

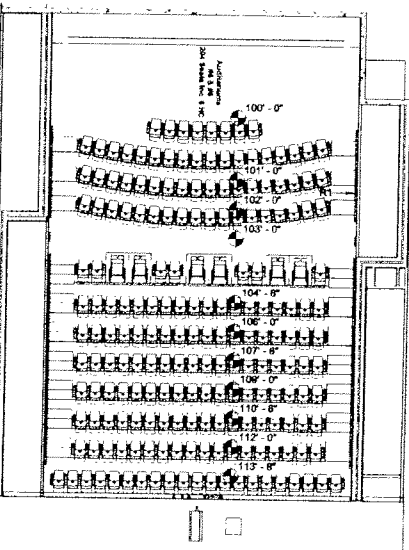

A AUD. #6 & #9 MEZZANINE PLAN
1/16" = 1'-0"



KC, MO 64105
PH (816) 842-7552
FAX (816) 842-1302



EPIC
DELTONA, FL
ADA WAIVER

DATE 03-03-10
PROJECT 9041

AC-5